

## 300mA, Low Noise, Ultra-Fast CMOS LDO Regulator with Soft Start Function

REV: 00

### General Description

The LD6912 is a micropower linear regulator, featuring low-noise, low-dropout and high ripple rejection ration. The precision of feedback reference voltage is within  $\pm 2\%$  and output current is up to 300mA. As well, the LD6912 can be stable with an output capacitor of  $1\mu\text{F}$  which reduces the board space and cost.

The LD6912 is available in a space saving SOT23-5 or SC70-5 package.

+Patented

### Features

- Shutdown current  $< 1\mu\text{A}$
- Ultra-Fast Response in Load Transient
- High PSRR 70dB@1KHz
- Thermal Shutdown and Current Limiting Protection
- $V_{\text{OUT}}$  Discharge Function
- Stable with  $1\mu\text{F}$  Output Capacitor
- Soft Start Operation
- Output Voltage: 1.5V to 3.3V (step 0.1V)

### Applications

- Battery-Powered Equipment
- Hand-Held Instruments

### Typical Application

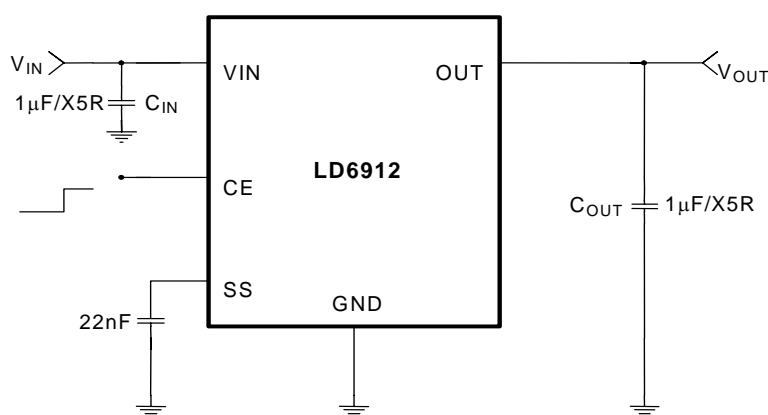
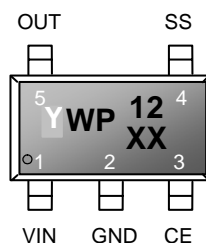

Fig.1 Typical Application Circuit

## Pin Configuration

SOT-23-5 (TOP VIEW)



SC70-5 (TOP VIEW)

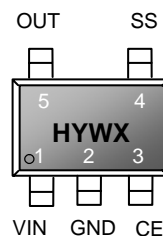

YY, Y: Year code (E: 2005, F: 2006.....)  
 WW, W: Week code  
 P: LD69..  
 (Product family code)  
 XX: Output Voltage

H: Product code: LD6912  
 Y: Year code (E: 2005, F: 2006.....)  
 W: Week code  
 X: Output Voltage (1~9: 1.5V~2.3V, a~j:  
 2.4V~ 3.3V)

## Ordering Information

Part number	Package	TOP MARK	Shipping
LD6912 PL-XX	SOT23-5	YWP/12XX	3000 /tape & reel
LD6912 GL-XX	SOT23-5 (Green Package)	YWP/12XX	3000 /tape & reel
LD6912 PU-XX	SC70-5	HYWX	3000 /tape & reel
LD6912 GU-XX	SC70-5 (Green Package)	HYWX	3000 /tape & reel

Note 1: The LD6912 is ROHS compliant.

Note 2: Part number XX: Output voltage, ex: 15:1.5V, .... 33:3.3V (step 0.1V)

## Pin Descriptions

SOT23-5

PIN	NAME	FUNCTION
1	VIN	Input Voltage
2	GND	IC GND
3	CE	Chip Enable, High=Enable, Low=Disable
4	SS	This pin combines noise reduction and soft start function. Connect a capacitor to GND to adjust soft start time. $C_{ss} > 1nF$ is recommended.
5	OUT	Regulator output

**SC70-5**

PIN	NAME	FUNCTION
1	VIN	Input Voltage
2	GND	IC GND
3	CE	Chip Enable, High=Enable, Low=Disable
4	SS	This pin combines noise reduction and soft start function. Connect a capacitor to GND to adjust soft start time. $C_{ss} > 1nF$ is recommended.
5	OUT	Regulator output

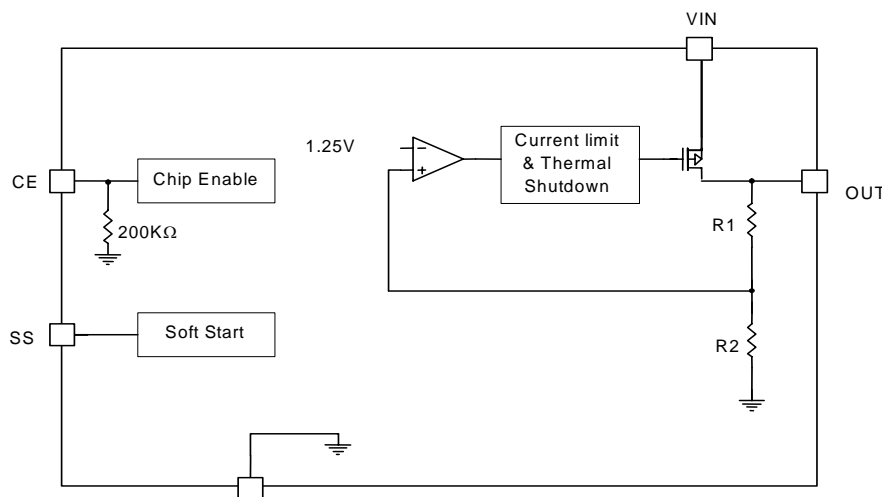
**Block Diagram**

**Absolute Maximum Ratings**

VIN, VOUT Pin.....	-0.3V~6V
SS, CE Pin.....	-0.3V~(VIN+0.3)V
Power dissipation SOT23-5@Ta=25°C.....	400mW
Power dissipation SC70-5@Ta=25°C.....	300mW
Operating Temperature Range.....	-40°C to 85°C
Package Thermal Resistance SOT23-5.....	250°C/W
Package Thermal Resistance SC70-5.....	333°C/W
Storage Temperature Range.....	-55°C to 125°C
Lead temperature (Soldering, 10sec).....	260°C
ESD Level (Human Body Model).....	2KV
ESD Level (Machine Model).....	200V

**Caution:**

Stresses beyond the ratings specified in "Absolute Maximum Ratings" may cause permanent damage to the device. This is a stress only rating and operation of the device at these or any other conditions above those indicated in the operational sections of this specification is not implied.

**Electrical Characteristics**

( $T_A = +25^\circ\text{C}$  unless otherwise stated,  $V_{IN}=V_{OUT}+1\text{V}$ ,  $C_{IN}=C_{OUT}=1\mu\text{F}$ ,  $C_{SS}=22\text{nF}$ )

PARAMETER	CONDITIONS	MIN	TYP	MAX	UNITS
<b>INPUT POWER</b>					
Input Voltage		2.8	-	5.5	V
Quiescent Current	$V_{IN}>1.2\text{V}$ , $I_{OUT}=0\text{mA}$	-	140	200	$\mu\text{A}$
Shutdown Supply Current	CE=GND	-		1	$\mu\text{A}$
<b>Dropt Voltage</b>					
Dropt Voltage	$I_{OUT}=200\text{mA}$ , $V_{OUT}>2.8\text{V}$		170	200	mV
	$I_{OUT}=300\text{mA}$ , $V_{OUT}>2.8\text{V}$		220	300	mV
<b>Soft Start</b>					
Soft Start Current		-	7.5	-	$\mu\text{A}$
<b>OUTPUT</b>					
Output Current Limit	$R_{LOAD}=1\Omega$	330	420	-	mA
Output Voltage Accuracy	$I_{OUT}=1\text{mA}$	-2		+2	%
Line Regulation	$V_{IN}=V_{out}+1\text{V}$ , to 5.5V, $I_{OUT}=1\text{mA}$	-	0.02	0.2	%/V
Load Regulation	$1\text{mA}<I_{OUT}<300\text{mA}$	-		0.6	%
Ripple Rejection	F=120Hz, $E_{IN}=1\text{Vrms}$ , $I_{OUT}=10\text{mA}$	-	70	-	dB
	F=10KHz, $E_{IN}=1\text{Vrms}$ , $I_{OUT}=10\text{mA}$	-	60	-	dB
Output Noise Voltage	$V_{OUT}=3.1\text{V}$ , 100Hz~100KHz $I_{OUT}=0\text{mA}$	-	40	-	$\mu\text{Vrms}$
Discharge Current	CE=High to Low	-	30	-	mA
<b>CE</b>					
Impedance to GND			200		$\text{K}\Omega$
CE Input Level	Enable	1.5	-	-	V
	Disable	-	-	0.6	V
<b>THERMAL PROTECTION</b>					
Thermal Shutdown	$V_{OUT}$ short to GND		145		$^\circ\text{C}$
Hysteresis			30		$^\circ\text{C}$

**Typical Performance Characteristics**

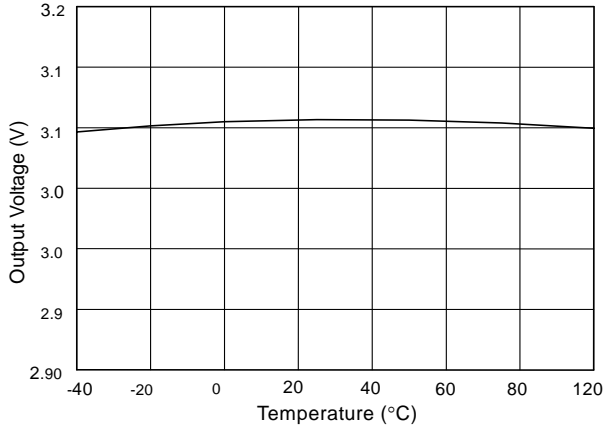

Fig.2 Output Voltage vs. Temperature

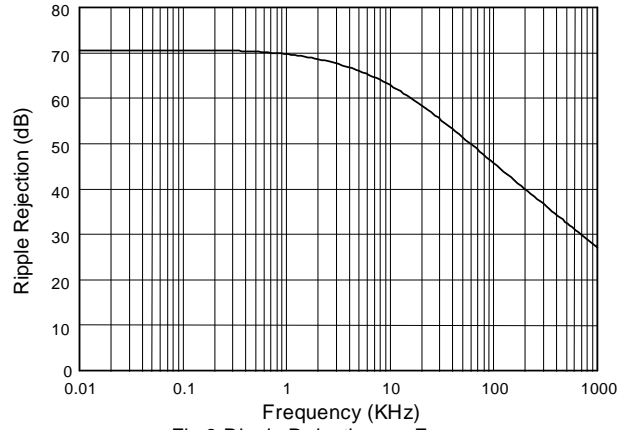

Fig.3 Ripple Rejection vs. Frequency

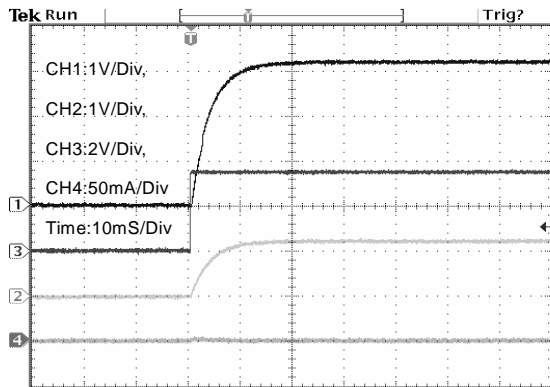

Fig.4 Start Up Waveform  $C_{SS}=22nF$

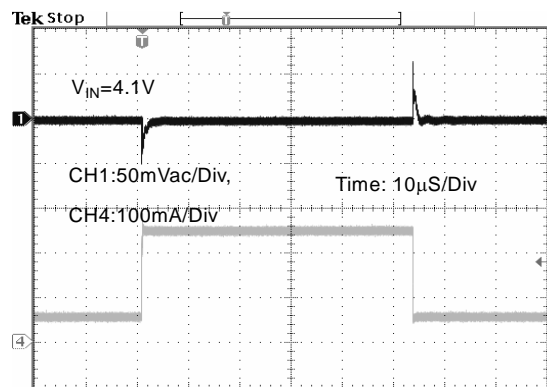

Fig.5 Load Transient Response

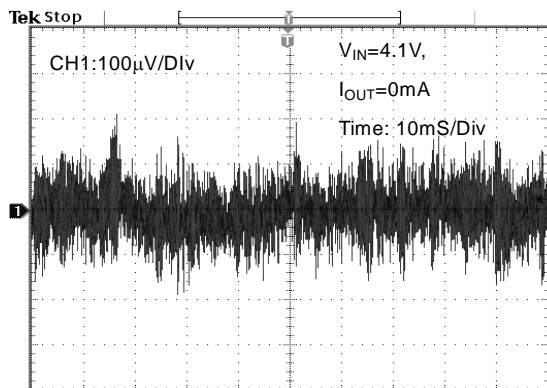

Fig.6 Output Noise

## Application Information

### Operation Overview

An input capacitor is necessary to place between the input and GND to stabilize  $V_{IN}$ . The input capacitor should be at least  $1\mu\text{F}$  to obtain beneficial effect. Besides, the input capacitor should be located in the distance within 5 mm from the VIN pin.

For stable operation, the output capacitor should be at least  $1\mu\text{F}$  with  $\text{ESR} > 25\text{ m}\Omega$ . The figure 1 shows the curves of the allowable ESR range as a function of load current for  $C_{OUT}=1\mu\text{F}$ .

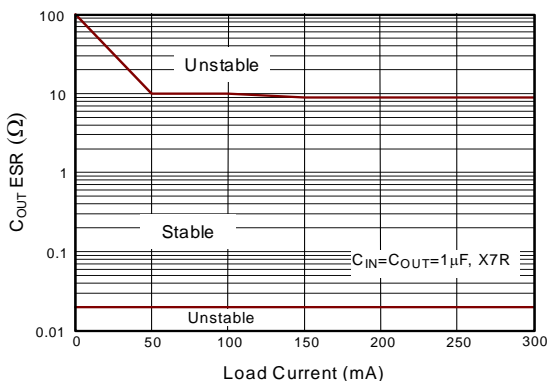

Fig. 7 Region of Stable  $C_{OUT}$  ESR vs. Load Current

Output capacitor of larger capacitance can reduce noise and improve load transient response, stability and PSRR. The output capacitor should be located in the distance within 5mm from the OUT pin.

X5R or X7R types of capacitors are recommended for the input and output capacitors.

### Current Limit

Output current is limited to 420mA (typical). When current limit engages, the output voltage scales back linearly until the overcurrent condition ends. Take care not to exceed the power dissipation ratings of the package.

### Thermal Consideration

When the junction temperature exceeds  $T_j=145^\circ\text{C}$ , the thermal sensor will turn off the pass transistor and allowing the IC to cool. The thermal sensor turns the pass transistor on after the IC's junction temperature cools by  $30^\circ\text{C}$  (typical). For continuous operation, do not exceed absolute maximum operation junction temperature at  $125^\circ\text{C}$ . The maximum power dissipation can be decided according to following equation.

$$P_{D(\text{MAX})} = \frac{(T_{J(\text{MAX})} - T_A)}{\theta_{JA}}$$

$\theta_{JA}$ : Package Thermal Resistance

The maximum power dissipation at  $T_a=25^\circ\text{C}$  can be obtained by above formula.

$$P_{D(\text{MAX})} = (125^\circ\text{C} - 25^\circ\text{C}) / 250 = 400\text{mW} \text{ (SOT23-5 package)}$$

$$P_{D(\text{MAX})} = (125^\circ\text{C} - 25^\circ\text{C}) / 333 = 300\text{mW} \text{ (SC70-5 package)}$$

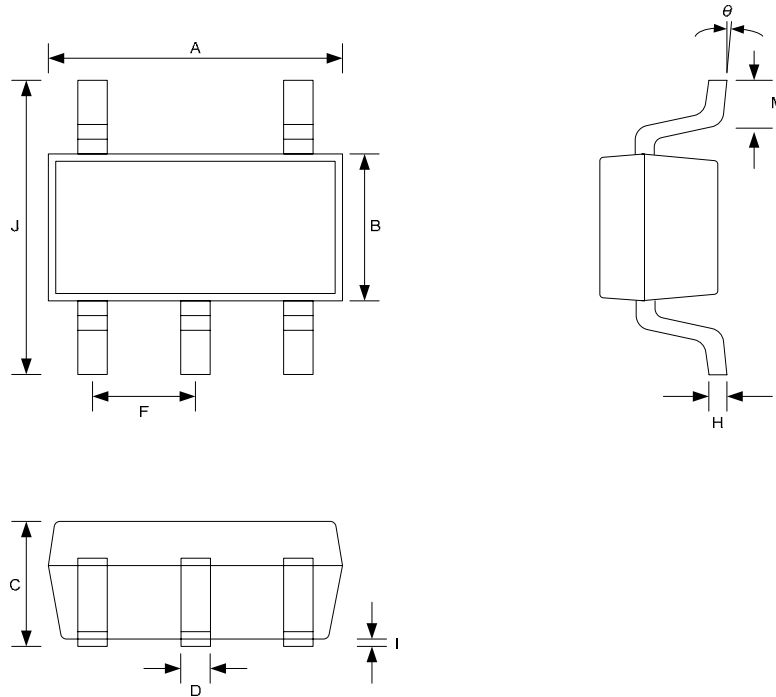
**Package Information**
**SOT23-5**

Symbol	Dimension in Millimeters		Dimensions in Inches	
	Min	Max	Min	Max
A	2.692	3.099	0.106	0.122
B	1.397	1.803	0.055	0.071
C	-----	1.450	-----	0.058
D	0.300	0.550	0.012	0.022
F	0.838	1.041	0.033	0.041
H	0.080	0.254	0.003	0.010
I	0.050	0.150	0.002	0.006
J	2.600	3.000	0.102	0.118
M	0.300	0.600	0.012	0.024
$\theta$	0°	10°	0°	10°

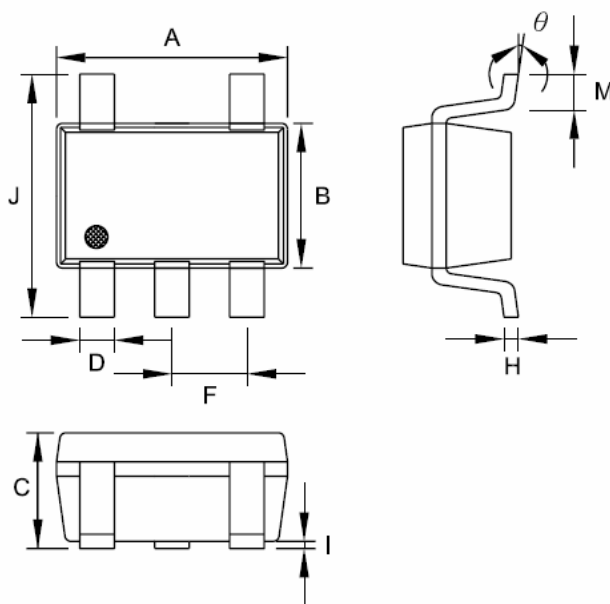
**SC70-5**

Symbol	Dimension in Millimeters		Dimensions in Inches	
	Min	Max	Min	Max
A	1.90	2.10	0.075	0.083
B	1.15	1.35	0.045	0.053
C	0.90	1.10	0.035	0.043
D	0.20	0.40	0.008	0.016
F	0.65 TYP.		0.026 TYP.	
H	0.10	0.15	0.004	0.006
I	0.025	0.10	0.001	0.004
J	2.00	2.20	0.079	0.087
M	0.10	0.40	0.004	0.016
$\theta$	0°	8°	0°	8°

**Important Notice**

Leadtrend Technology Corp. reserves the right to make changes or corrections to its products at any time without notice. Customers should verify the datasheets are current and complete before placing order.



**Revision History**

Rev.	Date	Change Notice
00	9/8/2006	Original Specification.