

## 500mA, Ultra-Low Noise, High PSRR CMOS LDO Regulator with Soft Start Function

REV: 01

### General Description

The LD6922 is a micro power linear regulator with minimum output voltage drop during load transient, featuring ultra-low noise, low-dropout and high ripple rejection ratio for optimal performance of battery-powered systems. This SS pin can suppress the noise and is built in with soft start function. As well, the LD6922 is stable with an output capacitor of  $1\mu\text{F}$  which reduces the board space and cost.

The LD6922 is available in a space saving SC82-4, SOT23-5, SC70-5, SC70-6, and WDFN-6L 1.6mm x 1.6mm package.

+Patented

### Features

- Wide Operating Input Voltage Range : 2.5V to 5.5V
- Minimum Output Voltage Drop during Load Transient
- Ultra-Low Noise for RF Application
- Shutdown Current  $<1\mu\text{A}$
- High PSRR 70dB@1kHz
- Stable with  $1\mu\text{F}$  Output Capacitor
- Thermal Shutdown and Current Limiting Protection
- $V_{\text{OUT}}$  Discharge Function
- Soft Start Operation
- Fixed Output Voltage: 1.2V to 3.3V (step : 0.1V), and 3.45V.

### Applications

- Battery-Powered Equipment
- Hand-Held Instruments
- Palmtops, Notebook Computers

### Typical Application

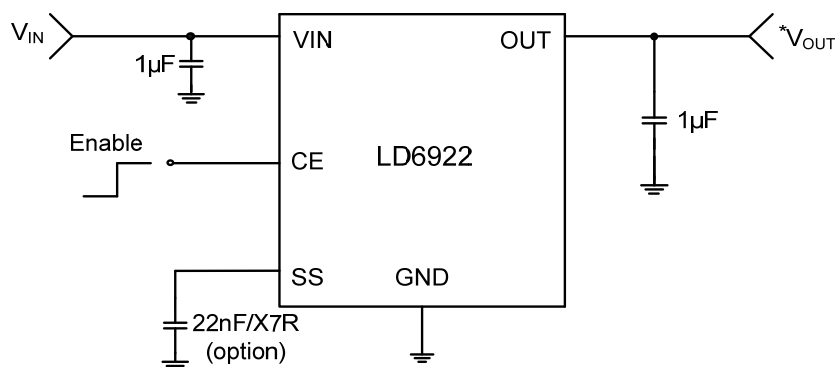
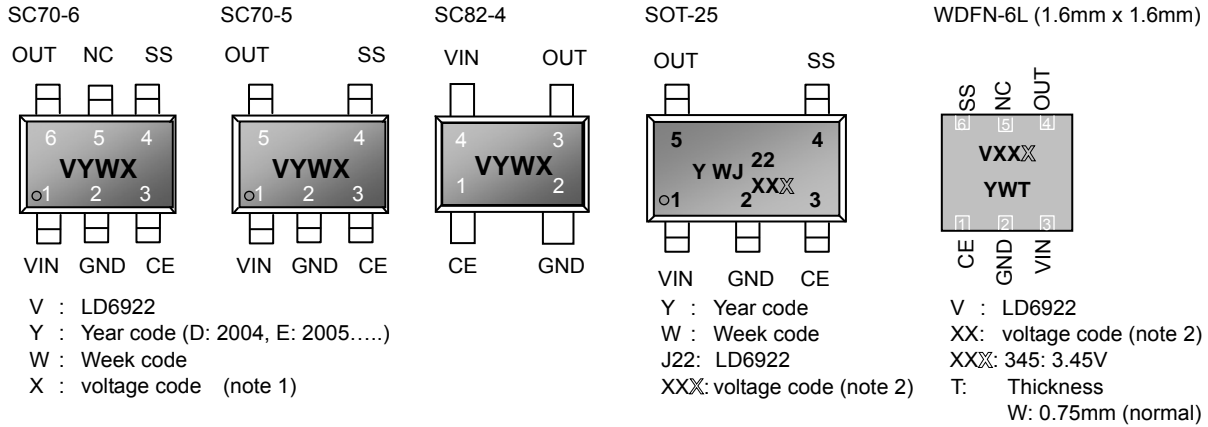

Fig. 1 Typical Application Circuit for General Purpose

## Pin Configuration



\*Note 1 : Voltage Code for SC70-6, SC70-5, SC82-4

Code	E	F	G	H	I	J	K	L	M	N	O	P	Q	R	S	T	U	V	W	X
(V)	1.2	1.3	1.4	1.5	1.6	1.7	1.8	1.9	2.0	2.1	2.2	2.3	2.4	2.5	2.6	2.7	2.8	2.9	3.0	3.1

Code	Y	Z	5
(V)	3.2	3.3	3.45

\*Note 2 : Voltage Code for SOT-25, WDFN-6L

Code	12	13	14	15	16	17	18	19	20	21	22	23	24	25	26	27	28	29	30	31
(V)	1.2	1.3	1.4	1.5	1.6	1.7	1.8	1.9	2.0	2.1	2.2	2.3	2.4	2.5	2.6	2.7	2.8	2.9	3.0	3.1

Code	32	33	345
(V)	3.2	3.3	3.45

## Ordering Information

Part number	Package	TOP MARK	Shipping
LD6922 GF-XXX	SC82-4	VYWX	3000 /tape & reel
LD6922 GL-XXX	SOT25	YWJ/22XX	3000 /tape & reel
LD6922 GC- XXX	SC70-5	VYWX	3000 /tape & reel
LD6922 GU- XXX	SC70-6	VYWX	3000 /tape & reel
LD6922 GDAW- XXX	WDFN-6L 1.6mm×1.6mm	VXXX	2500 /tape & reel

Note 1: The LD6922 is Green Packaged.

Note 2: Part number XXX: Output voltage, ex: 12:1.2V.... 33:3.3V (step 0.1V) and 3.45V

## Pin Descriptions

### SC82-4

PIN	NAME	FUNCTION
1	CE	Chip Enable, High=Enable, Low=Disable
2	GND	IC GND
3	OUT	Regulator output
4	VIN	Input Voltage

### SOT23-5, SC70-5

PIN	NAME	FUNCTION
1	VIN	Input Voltage
2	GND	IC GND
3	CE	Chip Enable, High=Enable, Low=Disable
4	SS	This pin combines noise reduction and soft start function. Connect a capacitor to GND to adjust soft start time.
5	OUT	Regulator output

### SC70-6

PIN	NAME	FUNCTION
1	VIN	Input Voltage
2	GND	IC GND
3	CE	Chip Enable, High=Enable, Low=Disable
4	SS	This pin combines noise reduction and soft start function. Connect a capacitor to GND to adjust soft start time.
5	NC	No connection
6	OUT	Regulator output

### WDFN-6L

PIN	NAME	FUNCTION
1	CE	Chip Enable, High=Enable, Low=Disable
2	GND	IC GND
3	VIN	Input Voltage
4	OUT	Regulator output
5	NC	No connection
6	SS	This pin combines noise reduction and soft start function. Connect a capacitor to GND to adjust soft start time.

## Block Diagram (SC70-6)

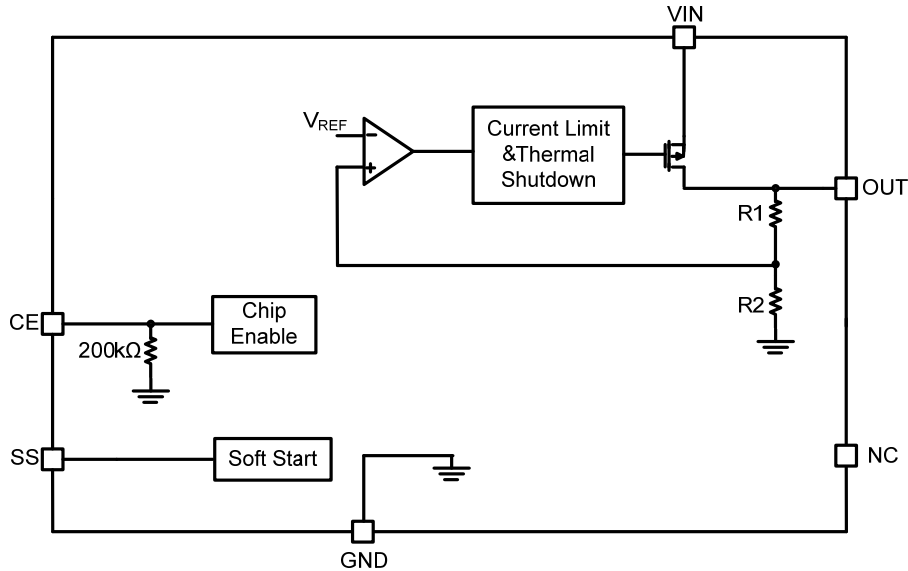

## Absolute Maximum Ratings

VIN, VOUT Pin.....	-0.3V~6V
SS, CE Pin.....	-0.3V~ (VIN+0.3) V
Power dissipation SC82-4@Ta=25°C.....	300mW
Package Thermal Resistance SC82-4.....	333°C/W
Power dissipation SOT23-5@Ta=25°C.....	400mW
Package Thermal Resistance SOT25.....	250°C/W
Power dissipation SC70-5@Ta=25°C.....	300mW
Package Thermal Resistance SC70-5.....	333°C/W
Power dissipation SC70-6@Ta=25°C.....	300mW
Package Thermal Resistance SC70-6.....	333°C/W
Power dissipation WDFN-6L 1.6×1.6 @TA=25°C.....	571mW
Package Thermal Resistance WDFN-6L 1.6×1.6.....	175°C/W
Maximum Junction Temperature.....	150°C
Operating Junction Temperature.....	-40°C to 125°C
Operating Ambient Temperature.....	-40°C to 85°C
Storage Temperature Range.....	-55°C to 125°C
Lead temperature (Soldering, 10sec).....	260°C
ESD Level (Human Body Model).....	2kV
ESD Level (Machine Model).....	200V

### Caution:

Stresses beyond the ratings specified in "Absolute Maximum Ratings" may cause permanent damage to the device. This is a stress only rating and operation of the device at these or any other conditions above those indicated in the operational sections of this specification is not implied.

## Electrical Characteristics

( $V_{IN}=V_{OUT}+1V$ ,  $T_A = 25^\circ C$ , unless otherwise stated.  $C_{IN}=C_{OUT}=1\mu F$ ,  $C_{SS}=22nF$ ; the LD6922 is tested with 3.1V output, unless other stated.) (Note 1)

PARAMETER	CONDITIONS	MIN	TYP	MAX	UNITS
<b>INPUT POWER</b>					
Input Voltage		2.5	-	5.5	V
Quiescent Current	$C_E > 1.5V$ , $I_{OUT}=0mA$	-	80	105	$\mu A$
Shutdown Supply Current	$C_E = GND$	-	0.1	1	$\mu A$
<b>Dropt Voltage</b>					
Dropt Voltage (Note2)	$I_{OUT}=300mA$ , $3.6V \leq V_{IN} \leq 5.5V$		230	300	mV
	$I_{OUT}=500mA$ , $3.6V \leq V_{IN} \leq 5.5V$		380	500	mV
<b>Soft Start</b>					
Internal Soft Start Time		60	100	140	$\mu S$
<b>Output</b>					
Output Current Limit	$R_{LOAD}=1\Omega$	550	600		mA
Line Regulation	$V_{IN}=V_{OUT}+1V$ , to 5.5V, $I_{OUT}=1mA$	-	0.05	0.2	%/V
Load Regulation	$1mA < I_{OUT} < 300mA$ $V_{IN}=V_{OUT}+1V$ , $2.5V \leq V_{OUT} \leq 3.3V$	-		0.8	%
	$1mA < I_{OUT} < 500mA$ $V_{IN}=V_{OUT}+1V$ , $2.5V \leq V_{OUT} \leq 3.3V$			1.6	%
Ripple Rejection	$F=120Hz$ , $E_{IN}=1V_{rms}$ , $I_{OUT}=10mA$		70		dB
	$F=1kHz$ , $E_{IN}=1V_{rms}$ , $I_{OUT}=10mA$		70	-	dB
	$F=10kHz$ , $E_{IN}=1V_{rms}$ , $I_{OUT}=10mA$	-	65	-	dB
Output Noise Voltage	$V_{OUT}=1.8V$ , $I_{OUT}=0mA$ $C_{SS}=22nF$	-	35	-	$\mu V_{rms}$

PARAMETER	CONDITIONS	MIN	TYP	MAX	UNITS
Discharge Resistance in shutdown	CE=High to Low	-	80	160	$\Omega$
CE					
Impedance to GND			200		$k\Omega$
CE Input Level	Enable, $V_{IN}=2.5V\sim 5.5V$	1.5	-	-	V
	Disable, $V_{IN}=2.5V\sim 5.5V$	-	-	0.6	V
<b>THERMAL PROTECTION</b>					
Thermal Shutdown	$V_{OUT}$ short to GND		150		$^{\circ}C$
Hysteresis			30		$^{\circ}C$

Note1: Limits are 100% tested at  $T_A = +25^{\circ}C$ . Limits over operating range are guarantee by design.

Note2: the drop voltage is defined as  $V_{IN}-V_{OUT}$ , which is measured when  $V_{OUT}$  is  $V_{OUT}(\text{normal})-100mV$ .

## Typical Performance Characteristics

( $V_{IN}=V_{OUT}+1V$ ,  $C_{IN}=1\mu F$ ,  $C_{OUT}=1\mu F$ ,  $C_{SS}=22nF$ ,  $T_A = +25^{\circ}C$ , unless otherwise stated.)

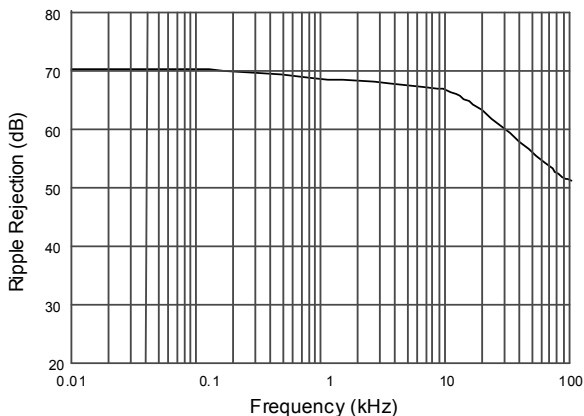

Fig.3 Ripple Rejection vs. Frequency

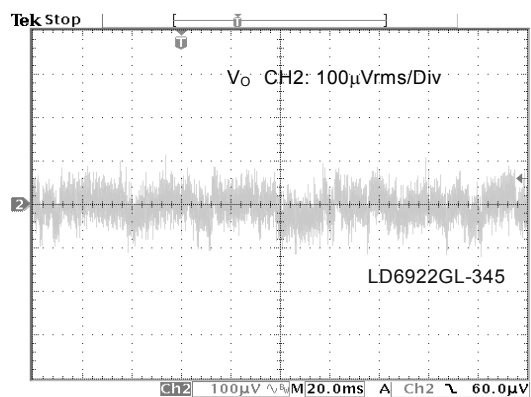
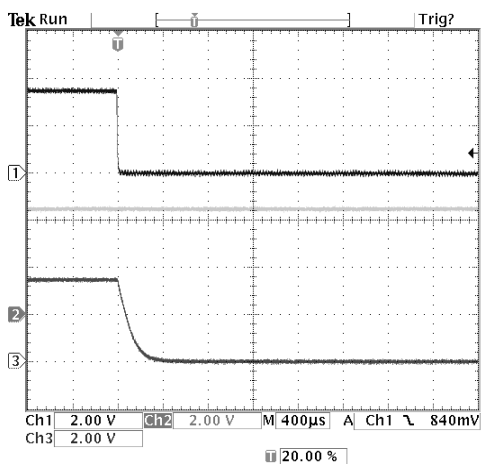
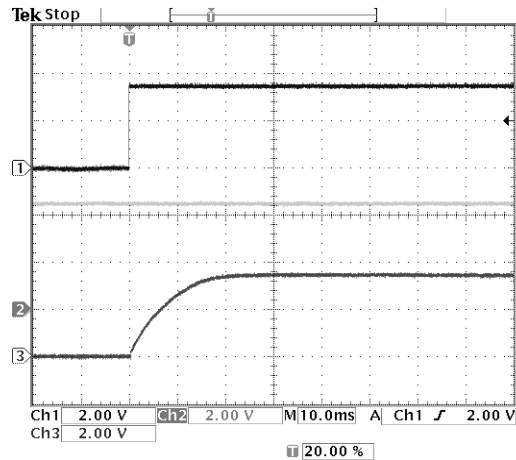
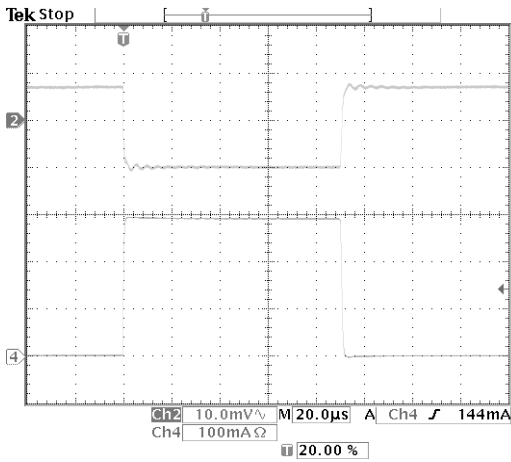

Fig.6 Output Noise ( $C_{SS}=22nF$ )



## Typical Performance Characteristics

( $V_{IN}=V_{OUT}+1V$ ,  $C_{IN}=4.7\mu F$ ,  $C_{OUT}=4.7\mu F$ ,  $C_{SS}=22nF$ ,  $T_A=+25^\circ C$ , unless otherwise stated.)

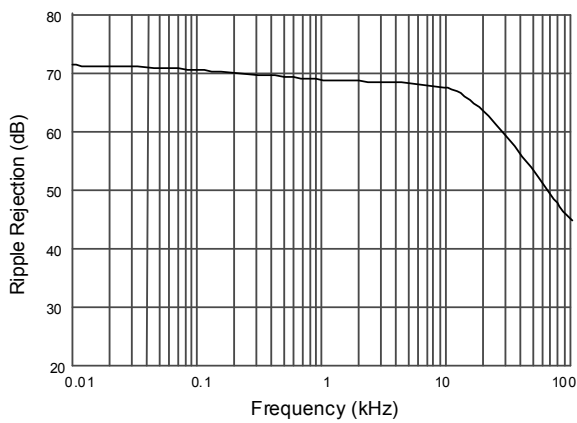

Fig.8 Ripple Rejection vs. Frequency

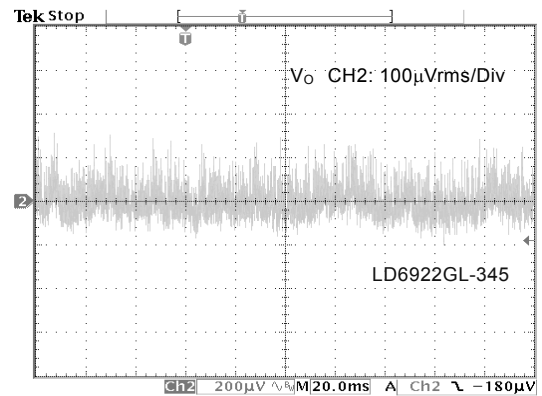
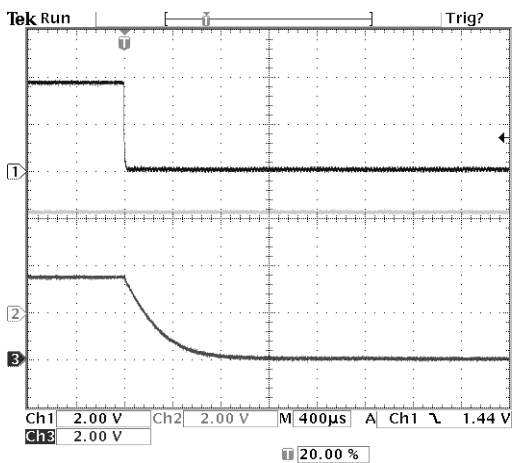
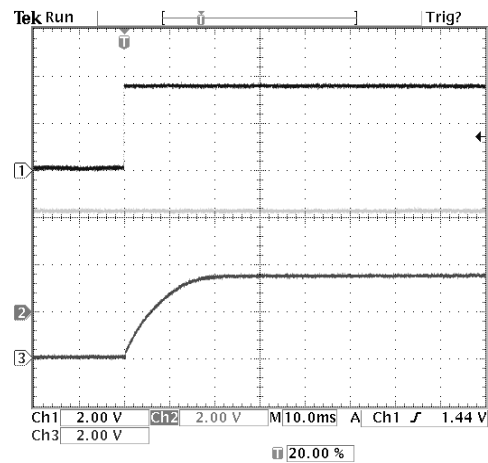
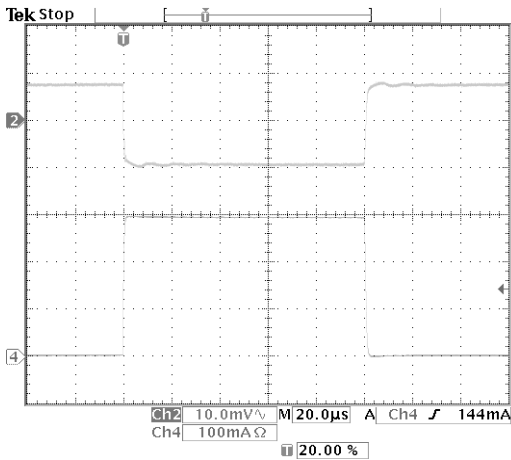

Fig.11 Output Noise ( $C_{SS}=22nF$ )



## Application Information

### Operation Overview

It's necessary to place an input capacitor of minimum value  $1\mu\text{F}$  between VIN and GND to stabilize. It's also recommended to locate it in the distance of 5mm from VIN.

The output capacitor is also recommended to place in the distance of 5mm from OUT pin. The LD6922 performs well in cooperating with low ESR ceramic output capacitor, ideally for compact applications. To enhance the stability, the ceramic capacitor of  $1\mu\text{F}$  at least and larger ESR than  $25\text{m}\Omega$  is preferable. X5R or X7R types of capacitor are always best suited for full range of operation temperature.

### Soft Start Operation and Noise Reduction

If an external soft start capacitor,  $C_{SS}$ , is used between SS and GND, it will provide soft start operation and reduce output noise efficiently. We can obtain the soft start time according to the following formula.

Where,

$T_{SS}$ : soft start time (ms)

$C_{SS}$ : soft start capacitor (nF)

EX:

$V_{OUT}=3.1\text{V}$  and  $C_{SS}=22\text{nF}$

The soft start time,  $TSS \approx 0.93 \times 22 = 20.46$  (ms)

The LD6922 is also built with internal soft start of  $60\sim 140\mu\text{S}$ , it's eliminable for an external soft start capacitor.

### Enable Function

The LD6922 features enable/ disable function. The CE pin will completely turn on the device once it receives input of logic high level over 1.5V. On the other hand, the device will enter shutdown mode when the voltage drops below 0.6V. In shutdown mode, it consumes current less than  $1\mu\text{A}$  (max).

### Current Limit

Output current is limited to 600mA (typical). When current limit engages, the output voltage scales back linearly until the over-current condition ends. Take care not to exceed the power dissipation ratings of the package.

### Thermal Consideration

When the junction temperature exceeds  $T_j=150^\circ\text{C}$ , the thermal sensor will turn off the pass transistor and cool down the IC. The thermal sensor turns on the pass transistor after the IC's junction temperature falls by  $30^\circ\text{C}$



(typical). For continuous operation, do not exceed absolute maximum operation junction temperature of 125°C. The maximum power dissipation is determined according to following equation.

$$P_{D(MAX)} = \frac{(T_{J(MAX)} - T_A)}{\theta_{JA}}$$

$\theta_{JA}$ : Package Thermal Resistance

The maximum power dissipation at  $T_a=25^\circ\text{C}$  can be obtained by above formula.

$$P_{D(MAX)} = (125^\circ\text{C} - 25^\circ\text{C}) / 250 = 400\text{mW}$$

.....( SOT23-5 package)

$$P_{D(MAX)} = (125^\circ\text{C} - 25^\circ\text{C}) / 333 = 300\text{mW}$$

.....( SC82-4 package)

$$P_{D(MAX)} = (125^\circ\text{C} - 25^\circ\text{C}) / 333 = 300\text{mW}$$

.....( SC70-5, SC70-6 package)

$$P_{D(MAX)} = (125^\circ\text{C} - 25^\circ\text{C}) / 175 = 571\text{mW}$$

.....(WDFN-6L 1.6x1.6 package)

## Package Information

SC82-4

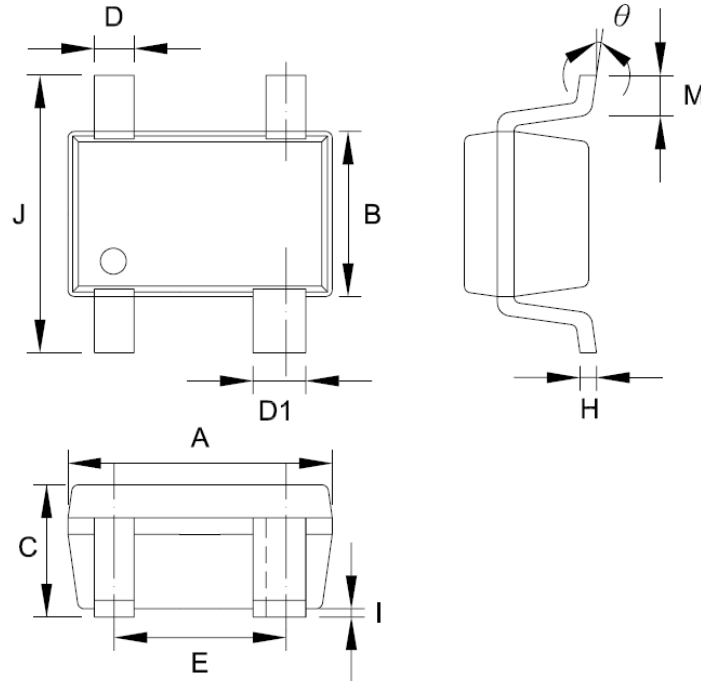

Symbol	Dimension in Millimeters		Dimensions in Inches	
	Min	Max	Min	Max
A	1.800	2.200	0.071	0.087
B	1.150	1.350	0.045	0.053
C	0.800	1.100	0.031	0.043
D	0.250	0.400	0.010	0.016
D1	0.350	0.500	0.014	0.020
E	1.300 TYP.		0.051 TYP.	
H	0.100	0.260	0.004	0.010
I	0.000	0.100	0.000	0.004
J	1.800	2.400	0.071	0.094
M	0.260	0.460	0.010	0.018
$\theta$	0°	8°	0°	8°

## SOT-25

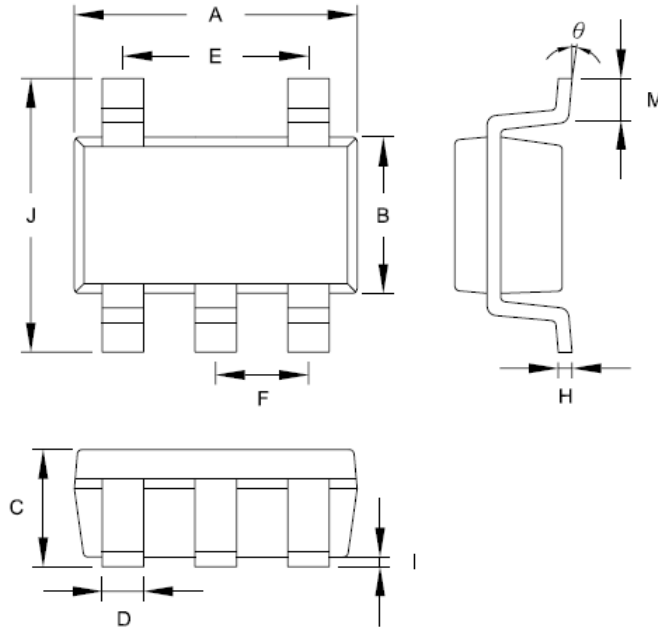

Symbol	Dimension in Millimeters		Dimensions in Inches	
	Min	Max	Min	Max
A	2.692	3.099	0.106	0.122
B	1.397	1.803	0.055	0.071
C	---	1.450	---	0.057
D	0.300	0.500	0.012	0.020
E	1.90 TYP		0.074 TYP	
F	0.95 TYP		0.037 TYP	
H	0.080	0.254	0.003	0.010
I	0.050	0.150	0.002	0.006
J	2.600	3.000	0.102	0.118
M	0.300	0.600	0.012	0.024
θ	0°	10°	0°	10°

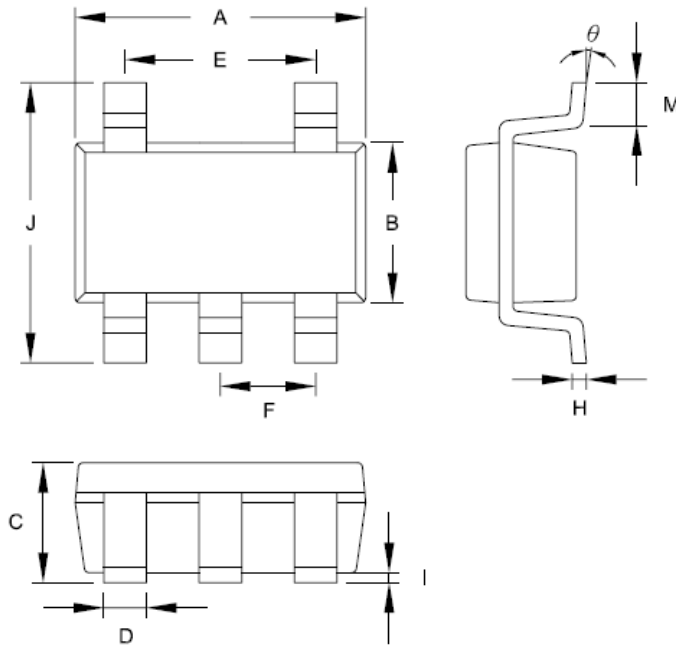
**SC70-5**

Symbol	Dimension in Millimeters		Dimensions in Inches	
	Min	Max	Min	Max
A	1.800	2.200	0.071	0.087
B	1.150	1.350	0.045	0.053
C	0.800	1.100	0.031	0.043
D	0.150	0.400	0.006	0.012
E	1.30 TYP		0.051 TYP	
F	0.650 TYP		0.026 TYP	
H	0.080	0.250	0.003	0.010
I	0.000	0.100	0.000	0.004
J	1.800	2.400	0.071	0.094
M	0.200	0.460	0.009	0.018
θ	0°	8°	0°	8°

SC70-6

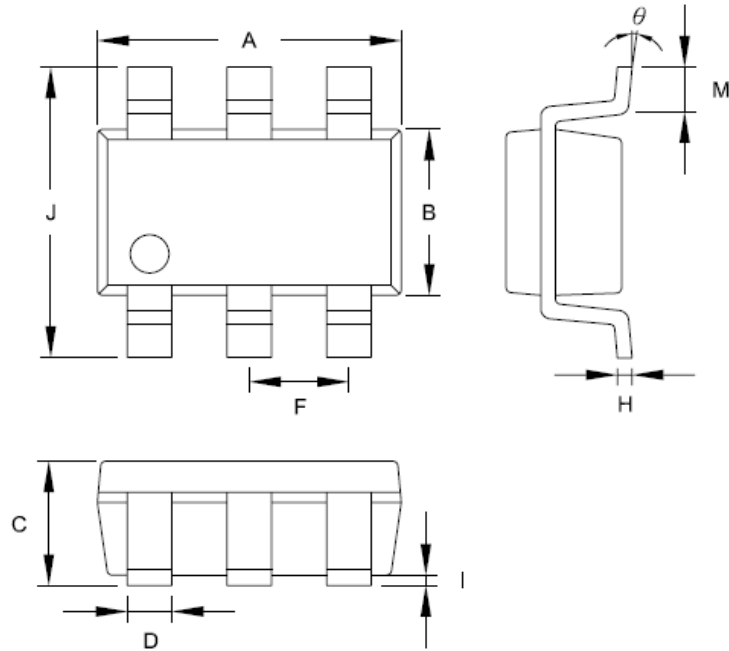

Symbol	Dimension in Millimeters		Dimensions in Inches	
	Min	Max	Min	Max
A	1.800	2.200	0.071	0.087
B	1.150	1.350	0.045	0.053
C	0.800	1.100	0.031	0.043
D	0.150	0.400	0.006	0.016
F	0.650 TYP		0.026 TYP	
H	0.080	0.250	0.003	0.010
I	0.000	0.100	0.000	0.004
J	1.800	2.400	0.071	0.094
M	0.200	0.460	0.009	0.018
$\theta$	0°	8°	0°	8°

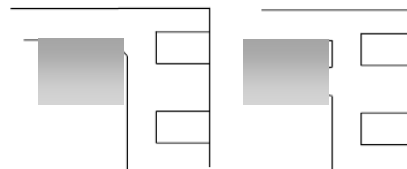
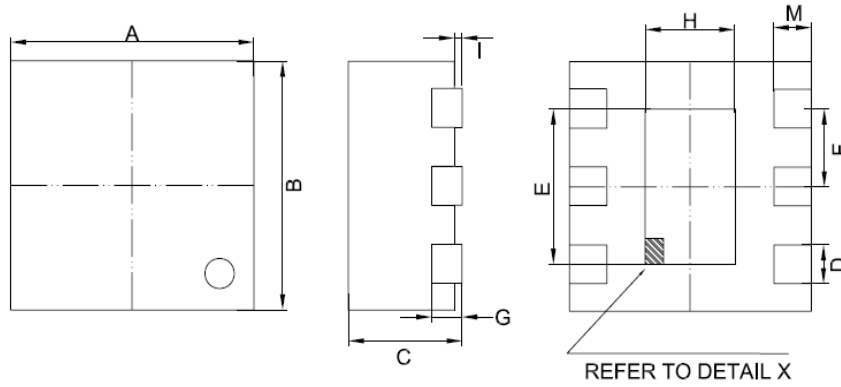
**WDFN-6L (1.6mm × 1.6 mm)**

**DETAIL X**  
 THE CONFIGURATION OF THE PIN 1  
 IDENTIFIER IS OPTIONAL AS ABOVE.

Symbol	Dimensions in Millimeters		Dimensions in Inches	
	Min.	Max.	Min.	Max.
<b>A</b>	1.500	1.700	0.059	0.067
<b>B</b>	1.500	1.700	0.059	0.067
<b>C</b>	0.700	0.800	0.028	0.031
<b>D</b>	0.200	0.300	0.008	0.012
<b>E</b>	0.900	1.100	0.035	0.043
<b>F</b>	0.500 TYP.		0.019 TYP.	
<b>G</b>	0.203 TYP.		0.008 TYP.	
<b>H</b>	0.500	0.700	0.020	0.028
<b>I</b>	0.000	0.050	0.000	0.002
<b>M</b>	0.200	0.300	0.009	0.012

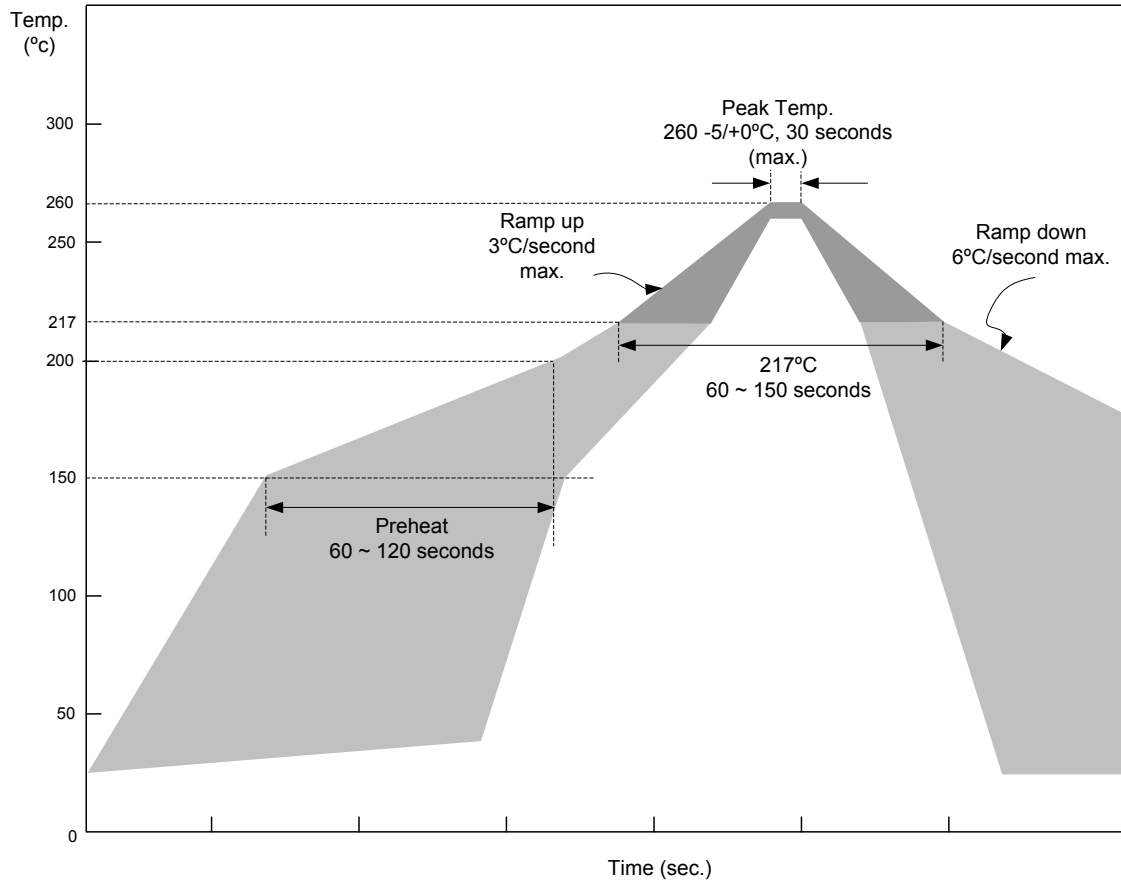
**IR Profile for SMD Devices**

Item	Average Ramp-up Rate	Pre-heat (150 ~ 200°C)	Time Maintained Above 217°C	Peak Temp.	Ramp-down Rate
Required	3°C(max) /sec	60~120 sec	60~150 seconds	260 $\pm$ 0/-5°C 30 seconds	6°C (max) /sec

**Important Notice**

Leadtrend Technology Corp. reserves the right to make changes or corrections to its products at any time without notice. Customers should verify the datasheets are current and complete before placing order.

**Revision History**

Rev.	Date	Change Notice
00	08/03/2011	Original Specification
01	09/01/2011	Package Option: SC70-5