

Photoflash Capacitor Charger

REV: 01

General Description

The LD7268 is an ideal charge control IC for flash units with internal soft start, adjustable charging current and output voltage. It provides a proprietary constant current charging algorithm which charges photoflash capacitor quickly and efficiently. Besides, the built-in totem pole IGBT driver can drive IGBT quickly and save board space.

For phone flash applications, the input current is usually limited at 500mA or 300mA. The LD7268 could easily meet either 500mA or 300mA applications.

The LD7268 is available in a space-saving MSOP-10 package and is ideal for phone flash or DSC flash unit.

Features

- Adjustable charging current
- Adjustable output voltage
- Supports auto refresh
- 2.8V~5V Lithium battery voltage range
- Internal soft start
- Tiny transformer
- Totem pole IGBT driver

Applications

- DSC Flash Unit
- Phone Flash Unit

† Patented

Typical Application

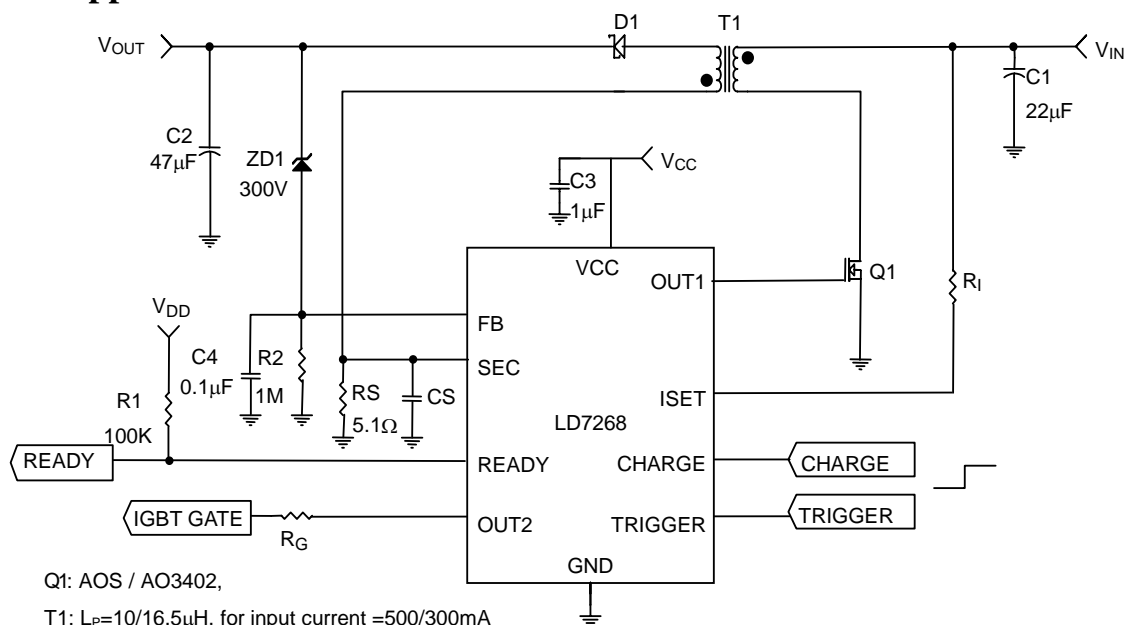

- Q1: AOS / AO3402,
 T1: $L_p=10/16.5\mu\text{H}$, for input current =500/300mA
 ZD1: Origin /FC0300M
 $R_1=250\text{K}-450\text{K}$
 $C_S=4.7-10\text{nF}$

Fig. 1 Phone Flash Application

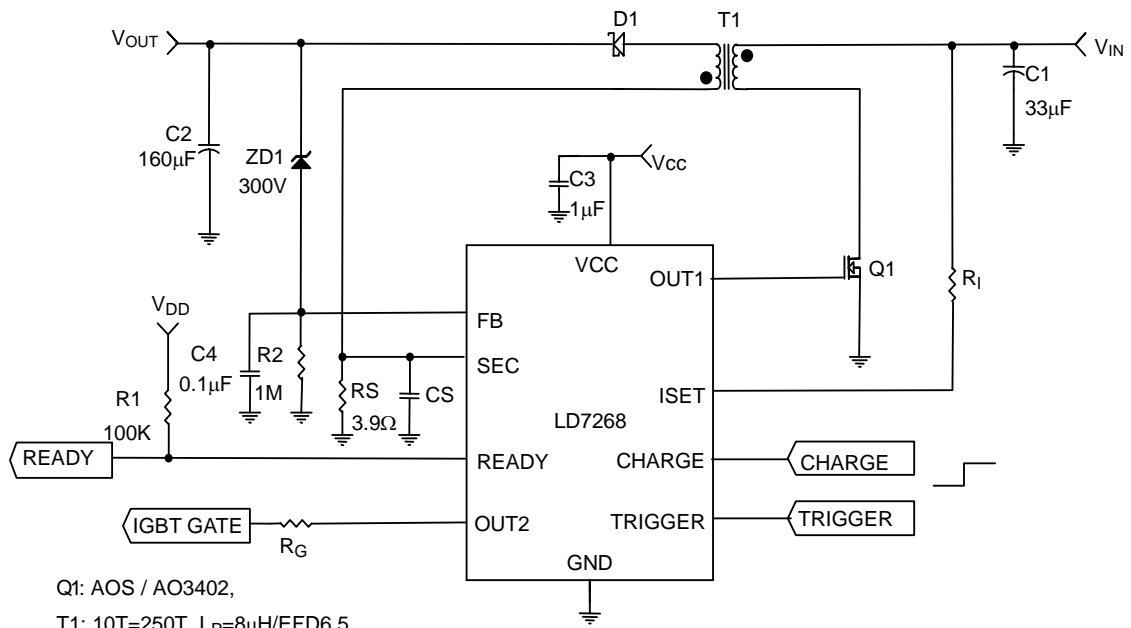

Q1: AOS / AO3402,
 T1: 10T=250T, L_p=8µH/EFD6.5
 ZD1: Origin/FC0300M
 R_I =250K-450K
 C_s=4.7-10nF

Fig. 2 Lithium Type DSC Flash Application

Pin Configuration

MSOP-10 (TOP VIEW)

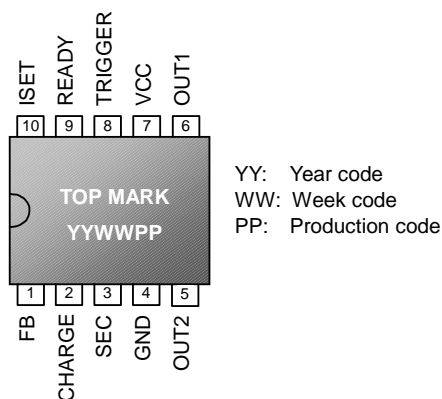
Ordering Information

Part number	Package	Top Mark	Shipping
LD7268 PL	MSOP-10 (PB FREE)	7268PL	2500 /tape & reel

Pin Descriptions

PIN	NAME	FUNCTION
1	FB	Output voltage feedback
2	CHARGE	Charging on/off control pin. High=enable Low=disable
3	SEC	Secondary winding pin
4	GND	IC GND
5	OUT2	Totem pole output (IGBT driver)
6	OUT1	Totem pole output (MOS driver)
7	VCC	Input power of IC
8	TRIGGER	Trigger on/off control pin. High=enable Low=disable
9	READY	Charge ready open drain output.
10	ISET	Adjust charging current with R to VBAT.

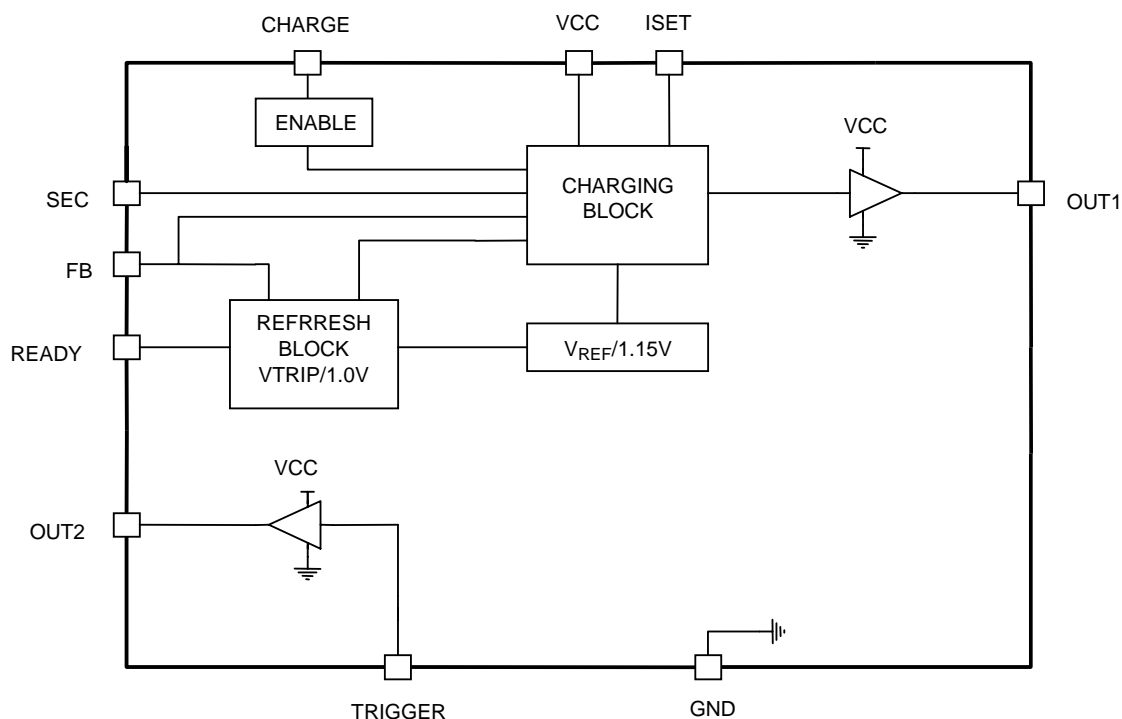
Block Diagram

Absolute Maximum Ratings

Supply Voltage Vcc.....	-0.3~6.0V
SEC pin.....	-0.6~(Vcc+0.3) V
FB, Charge, Trigger, ISET pin.....	-0.3~(Vcc+0.3) V
Operating Temperature Range.....	-30 °C to 85 °C
Storage Temperature Range.....	-55 °C to 125 °C
Junction Temperature.....	125 °C
Lead Temperature (Soldering, 10sec)(LD7268APL).....	260 °C
ESD Level (Human Body Model).....	2KV

Caution:

Stresses beyond the ratings specified in "Absolute Maximum Ratings" may cause permanent damage to the device. This is a stress only rating and operation of the device at these or any other conditions above those indicated in the operational sections of this specification is not implied.

Electrical Characteristics

 (T_A = +25°C unless otherwise stated, V_{CC}=3.3V)

PARAMETER	CONDITIONS	MIN	TYP	MAX	UNITS
INPUT POWER					
Operating Voltage V _{cc}		2.2		5.5	V
Standby Current I _{cc}	Charge Off		100		μA
Nominal Supply Current	V _{CC} =3.3V,D=50%		0.6		mA
FB					
Reference Voltage			1.15		V
Reference Voltage Tolerance				1	%
Auto Refresh Ref. Voltage1	V _{REF1} /V _{REF}		88		%
MOS Driver					
Rising Time	V _{CC} =3.3V,C _L =1nF		50		nS
Falling Time	V _{CC} =3.3V,C _L =1nF		50		nS
IGBT Driver					
Output ON resistor	V _{CC} =3.3V		8	12	Ω
Output OFF resistor	V _{CC} =3.3V		6	9	Ω
ON/OFF					
Trigger On/Off	Enable	2.0			V
	Disable			0.8	V
Charge On/Off	Enable	2.0			V
	Disable			0.8	V
Impedance to GND					
Charge Pin to GND			200K		Ω
Trigger Pin to GND			200K		Ω
Others					
Max Turn On Time	Ri Open		5		μS
Max Turn On Time Tolerance				6.6	%
Propagation Delay	(Trigger=High) delay to OUT2		60		nS

Typical Performance Characteristics

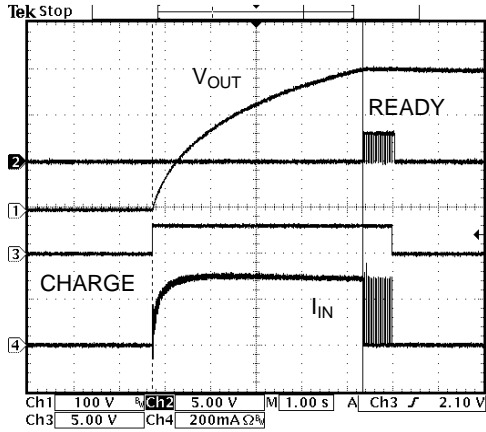

$I_{IN}=300\text{mA}$

Fig. 3 Charging waveform $V_{IN}=3.0\text{V}$

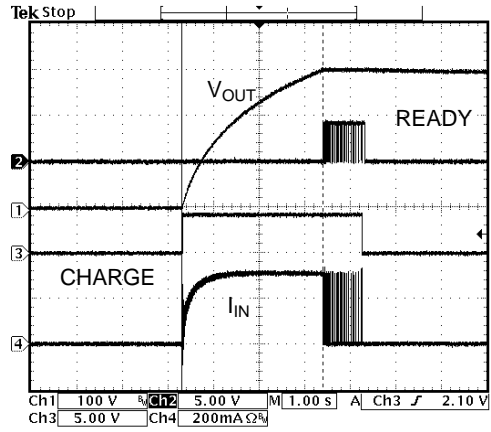

$I_{IN}=300\text{mA}$

Fig. 4 Charging waveform $V_{IN}=4.2\text{V}$

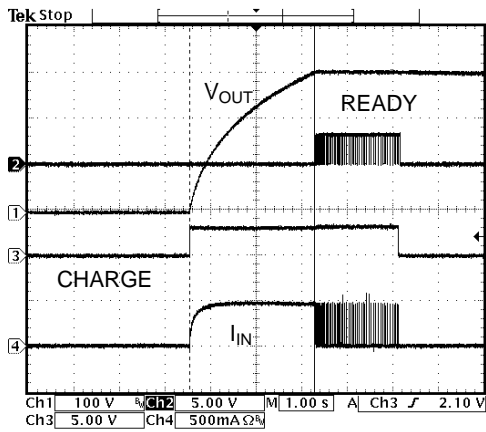

$I_{IN}=500\text{mA}$

Fig. 5 Charging waveform $V_{IN}=3.0\text{V}$

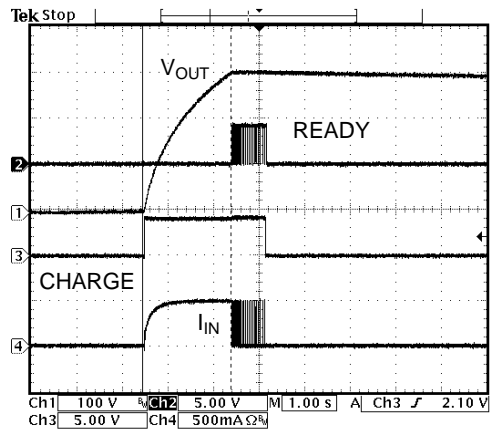

$I_{IN}=500\text{mA}$

Fig. 6 Charging waveform $V_{IN}=4.2\text{V}$

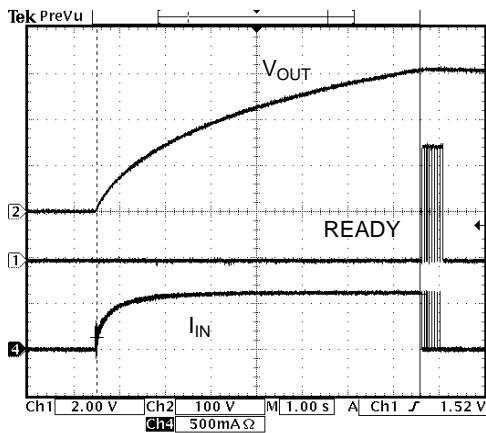

Fig. 7 Charging waveform $V_{IN}=3.0\text{V}$

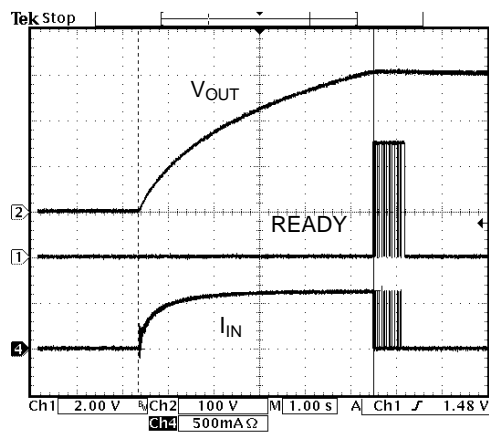

Fig. 8 Charging waveform $V_{IN}=4.2\text{V}$

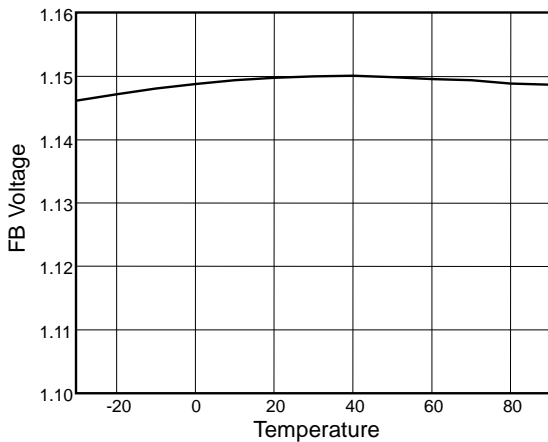

Fig. 9 FB Voltage vs. Temperature

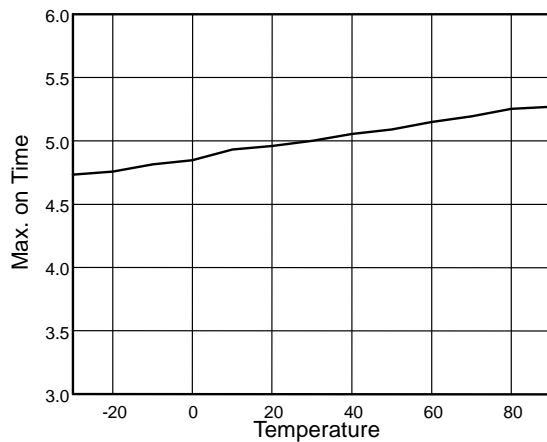

Fig. 10 Max. on Time vs. Temperature

Function Description

Transformer selection

The LD7268 is a highly integrated IC designed to charge photoflash capacitor in the camera phone. A new control technique allows the use of tiny transformers. Choosing a right transformer will result in the best performance and proper operation of the LD7268. Please use transformers of

- (1) $L_P=10\mu\text{H}$, for $I_{IN}=500\text{mA}$ phone flash application
- (2) $L_P=16.5\mu\text{H}$, for $I_{IN}=300\text{mA}$ phone flash application
- (3) $L_P=8\mu\text{H}$, for DSC flash application

Also, the turn ratio of the transformer should be considered. Choose it according to the V_{DS} rating of Q1. For example, if V_{DS} rating of Q1 is 30V, then please choose $N=25$.

Adjust charging current

The LD7268 provides a flexible way to adjust charging currents. Just adjust R_1 to achieve the desired peak primary charging current.

$$R_1 \approx 27L_P \times I_P \text{ K}\Omega$$

L_P : primary inductance (μH)

I_P : desired peak primary current (A)

Ex: Desired I_P is 1.4A, $L_P = 8\mu\text{H}$, then $R_1 = 301\text{K}/1\%$

Please always keep R_1 in the range of 250K to 450K to remain the constant charging current in the voltage range of 2.8V~5V. If the R_1 mentioned above can't meet the

application, please use larger L_P to adjust smaller I_P and vice versa.

Adjust output voltage

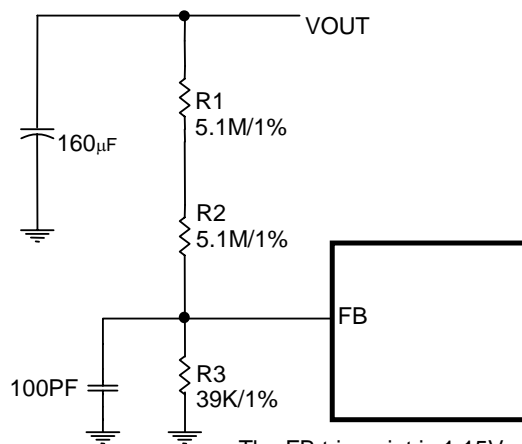

The FB trip point is 1.15V.

Fig.11

The LD7268 could sense output voltage by using an output resistor divider or a high voltage zener diode.

Fig. 11 shows the application circuit of resistor divider.

$$V_{OUT} = V_{FB} \times \left(1 + \frac{R_1 + R_2}{R_3}\right)$$

Auto refresh

The LD7268 supports auto refresh function for some DSC systems.

When V_{OUT} reaches its target value, the READY pin goes high, it means that the output voltage is high enough for the strobe to trigger. Then, V_{OUT} will decrease slightly due to some leakage currents.

The refresh block trip point is 1.0V (1.15V x 88%).

Please refer to Fig. 1.

While using a high voltage zener diode to detect V_{OUT} , the refresh time could be easily set by R2 and C4,

$$T_{refresh} = 0.12 R2 * C4$$

For R2=1M and C4=100nF,

$$T_{refresh} = 12 \text{ mS}$$

While V_{FB} is decreased to the refresh trip point, it enables the charging block and disables the refresh block. At the same time, the READY pin goes low, indicating that the LD7268 is in charging mode. This cycle of recharge operation will repeat again until charge pin is pulled low. Thus, the LD7268 could automatically recharge photoflash capacitor to maintain its target value.

To disable auto refresh function, pull low CHARGE pin while the first ready signal goes high.

Interface

CHARGE, READY and TRIGGER can be easily interfaced to a microprocessor.

The CHARGE pin is the on/off control of charging circuit.

High=enable Low =disable

The READY pin is an indicator of charging and output voltage state.

High= charging is completed and V_{OUT} is still higher than the refresh trip point

Low=otherwise

The TRIGGER pin is the on/off control of the strobe to generate a light pulse.

High=enable Low =disable

Note that the trigger function is only active while the CHARGE pin goes low.

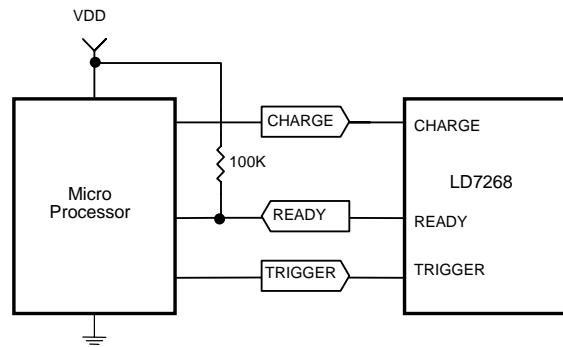
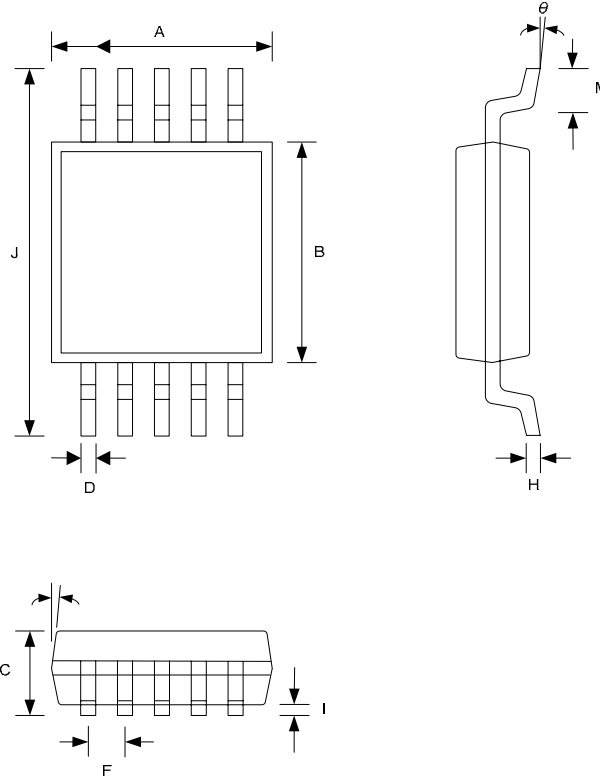

Fig. 12

Layout Consideration

1. The layout of this IC should be far away from any high voltage nodes or paths.
2. Keep the bypass capacitor 1 μ F very close to IC.
3. Keep output voltage feed back network, R₁, R₂, C₄, R_S and C_S very close to the IC.
4. The signal ground plane of FB and the SEC pin should be connected to the power ground with a via or only one point to minimize the effect of power ground currents.
5. The Switching paths or nodes, such as OUT1, gate or drain of Q1 should be routed away from ISET, FB and SEC pin.
6. The PCB traces carrying discontinuous currents and any high current path should be made as short and wide as possible.
7. Please refer to the EV kit for the example of the PCB layout.

Package Information
MSOP-10

Symbols	Dimensions in Millimeters		Dimensions in Inch	
	MIN	MAX	MIN	MAX
A	2.896	3.099	0.114	0.122
B	2.896	3.099	0.114	0.122
C	0.813	1.219	0.032	0.048
D	0.152	0.305	0.006	0.012
F	0.470	0.530	0.018	0.020
H	0.127	0.229	0.005	0.009
I	0.051	0.152	0.002	0.006
J	4.699	5.105	0.185	0.201
M	0.406	0.660	0.016	0.026
θ	0°	6°	0°	6°

Important Notice

Leadtrend Technology Corp. reserves the right to make changes or corrections to its products at any time without notice. Customers should verify the datasheets are current and complete before placing order.