

VFM STEP-UP DC/DC CONVERTER

REV: 01

General Description

The LD7282A is a VFM step-up DC/DC converter with ultra low supply current. The CMOS design results in less power consumption and high capability for battery-powered instruments.

With a built-in switching MOSFET, the LD7280 takes only three external components (using a coil, diode & capacitor connected externally) to achieve the low ripple & high efficiency.

As well, using chip enable function will make it possible to supply current on standby minimized. This converter also features a very low switch off, bias current of 5.0 μ A typical.

Features

- Minimum external component counts
- Ultra low input current in switch off (Typ. 5 μ A)
- $\pm 2\%$ High accuracy of output voltage
- Low ripple and low noise
- Low start-up voltage, 0.75V at no load.
- 85% efficiency with low cost inductor

Applications

- Power source for battery -powered equipment
- Power source for DSC, PDA, Camcorders, VCRs, Pagers, and Hand-held communication equipment

Typical Application

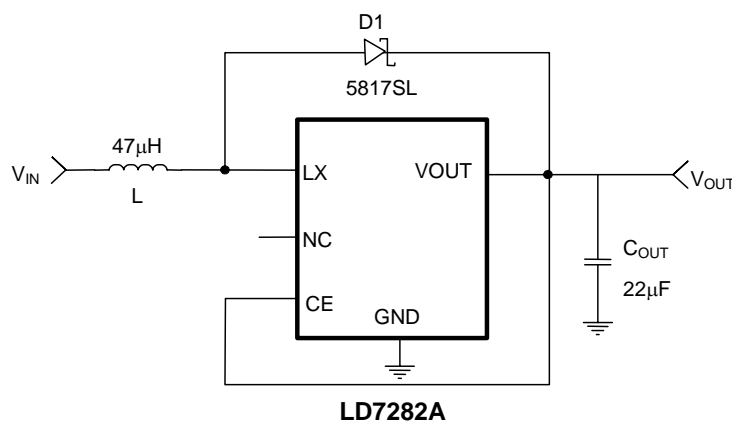

L range: 10 μ H~120 μ H

Fig. 1

Pin Configuration

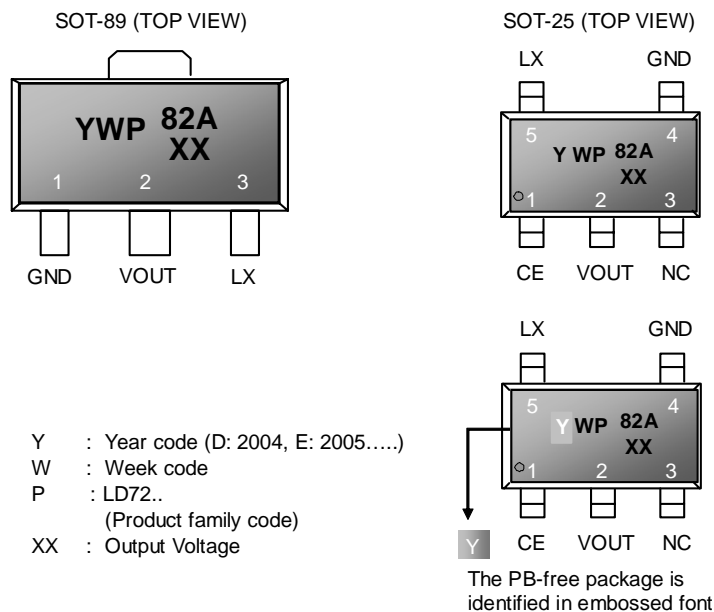

Ordering Information

Part number	Package	Top Mark	Shipping
LD7282A CL-XX	SOT-25	YWP82A/XX	3000 /tape & reel
LD7282A PL-XX	SOT-25 (PB FREE)	(*) YWP82A/XX	3000 /tape & reel
LD7282A CJ-XX	SOT-89	YWP82A/XX	1000 /tape & reel
LD7282A PJ-XX	SOT-89 (PB FREE)	(*) YWP82A/XX	1000 /tape & reel

(*) Identified in different laser ink

XX: Output voltage: 33: 3.3V, 50: 5.0V

Pin Descriptions

PIN		NAME	FUNCTION
CJ - XX	CL - XX		
1	4	GND	IC GND
2	2	VOUT	Output voltage
3	5	LX	Switching pin
-	1	CE	Chip enable High=enable Low=disable
-	3	NC	No connected

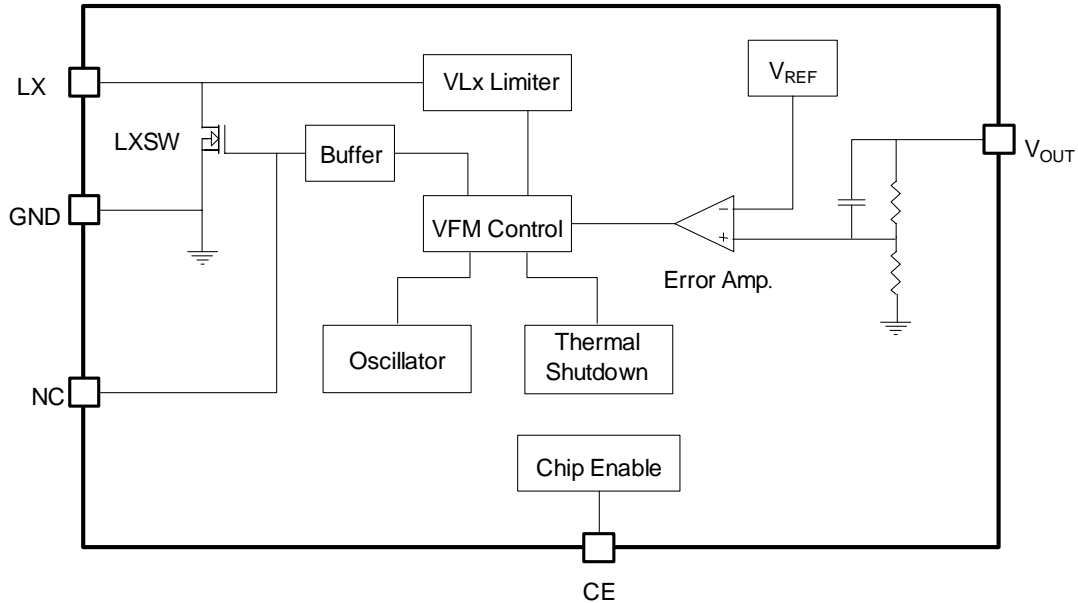
Block Diagram

Absolute Maximum Ratings

Output Voltage.....	-0.3~7V
LX Pin Voltage.....	-0.3~7V
CE Pin Voltage.....	-0.3 to $V_{OUT}+0.3V$
LX Pin Output Current.....	360mA
Power Dissipation SOT-89.....	500mW
Thermal Resistance SOT-89, θ_{JA}	300°C/W
Power Dissipation SOT-25.....	250mW
Thermal Resistance SOT-25, θ_{JA}	250°C/W
Operating Temperature Range.....	-30°C to 85°C
Storage Temperature Range.....	-55°C to 125°C
Junction Temperature.....	125°C
Lead Temperature (Soldering, 10sec)(LD7282ACL).....	230 °C
Lead Temperature (Soldering, 10sec)(LD7282APL).....	260°C
ESD Level (Human Body Model).....	2KV
ESD Level (Machine Model).....	200V

Caution:

Stresses beyond the ratings specified in "Absolute Maximum Ratings" may cause permanent damage to the device. This is a stress only rating and operation of the device at these or any other conditions above those indicated in the operational sections of this specification is not implied.

Electrical Characteristics

Unless otherwise stated, $T_A = +25^{\circ}\text{C}$, $V_{IN}=2.0\text{V}$ (When $V_{OUT}\leq 3.5\text{V}$), $I_{OUT}=10\text{mA}$; $V_{IN}=3.0\text{V}$ (When $3.5\text{V}<V_{OUT}\leq 4\text{V}$),

$I_{OUT}=10\text{mA}$

PARAMETER		CONDITIONS	MIN	TYP	MAX	UNITS		
V_{OUT}								
Output voltage accuracy			-2		+2	%		
Input								
Input voltage					6.5	V		
Start-up voltage			$I_{OUT}=0\text{mA}, V_{IN}=0 \rightarrow 2\text{V}$		0.75	1.0	V	
Hold-on voltage			$I_{OUT}=0\text{mA}, V_{IN}=2 \rightarrow 0\text{V}$		0.6		V	
No load Input current	$V_{OUT}\leq 3.5\text{V}$	$I_{OUT}=0\text{mA}$ (measured at V_{IN})		10		μA		
	$3.5\text{V}<V_{OUT}\leq 4\text{V}$			15				
IC supply current			Switch off		5	μA		
Oscillator								
Frequency				160		KHz		
Duty cycle				75		%		
LX								
LX switching current	$V_{OUT}\leq 3.5\text{V}$	$V_{LX}=0.4\text{V}$	120			mA		
	$3.5\text{V}<V_{OUT}\leq 4\text{V}$		160			mA		
V_{LX} voltage limit			LX switch on		0.37	0.5	0.63	V
LX leakage current			$V_{LX}< V_{OUT}+0.3\text{V}$			0.5	μA	
Chip Enable								
CE "H" level			$V_{IN}=V_{OUT} \times 0.9$		$0.4V_{OUT}$		V	
CE "L" level			$V_{IN}=V_{OUT} \times 0.9$			0.2	V	
Efficiency								
Efficiency			$V_{IN}=2.5\text{V}, V_{OUT}=3.3\text{V}, I_{OUT}=50\text{mA}$			85	%	
THERMAL PROTECTION								
Thermal Shutdown				150		$^{\circ}\text{C}$		
Hysteresis				20		$^{\circ}\text{C}$		

Typical Performance Characteristics

(L=47μH, C_{OUT}=22μF, V_{OUT}=3.8V)

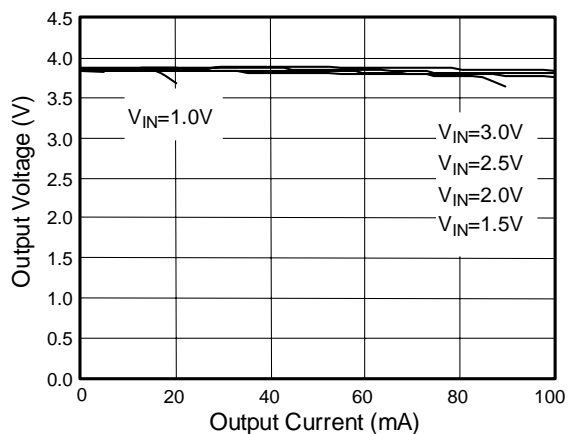

Fig. 2 Output voltage vs. Output Current

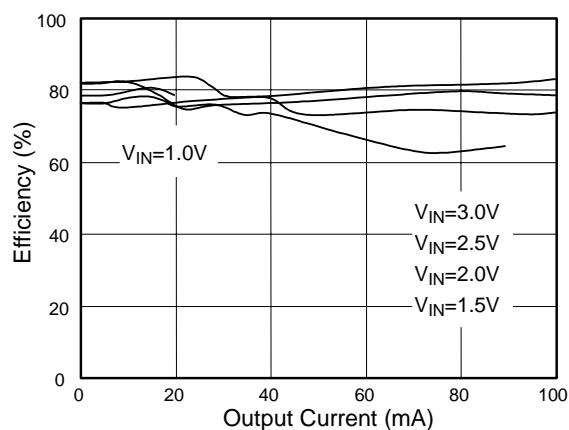

Fig. 3 Efficiency vs. Output Current

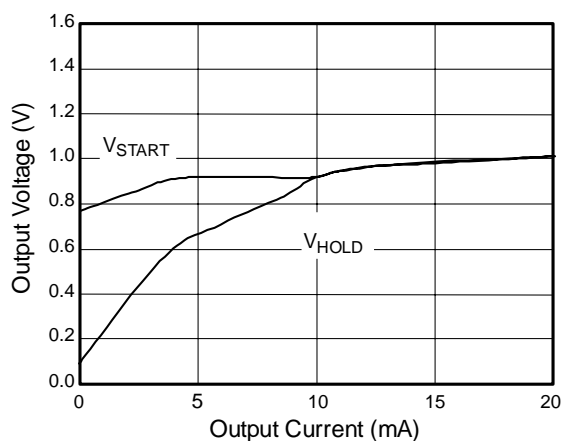

Fig. 4 Start-up/Hold-on Voltage vs. Output Current

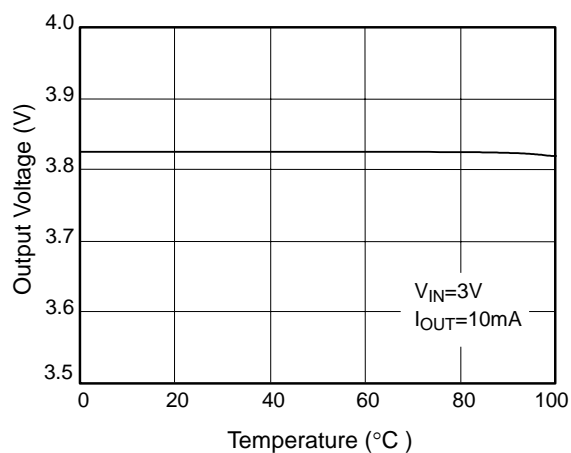
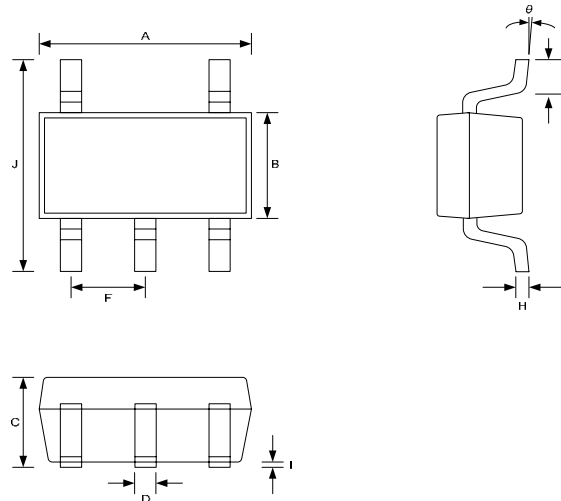

Fig. 5 Output Voltage vs. Temperature

Package Information

Package: SOT-25



Symbol	Dimension in Millimeters		Dimensions in Inches	
	Min	Max	Min	Max
A	2.692	3.099	0.106	0.122
B	1.397	1.803	0.055	0.071
C	-----	1.450	-----	0.058
D	0.300	0.550	0.012	0.022
F	0.838	1.041	0.033	0.041
H	0.080	0.254	0.003	0.010
I	0.050	0.150	0.002	0.006
J	2.600	3.000	0.102	0.118
M	0.300	0.600	0.012	0.024
θ	0°	10°	0°	10°

Package Information

Package: SOT-89

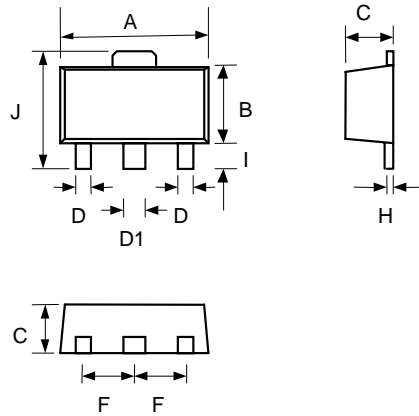

Symbols	Dimensions in Millimeters		Dimensions in Inch	
	MIN	MAX	MIN	MAX
A	4.394	4.597	0.173	0.181
B	2.290	2.600	0.094	0.102
C	1.397	1.600	0.055	0.063
D	0.356	0.483	0.014	0.019
D1	0.406	0.560	0.016	0.022
F	1.448	1.549	0.057	0.061
H	0.355	0.432	0.014	0.017
I	0.787	1.200	0.031	0.047
J	3.940	4.250	0.155	0.167

Important Notice

Leadtrend Technology Corp. reserves the right to make changes or corrections to its products at any time without notice. Customers should verify the datasheets are current and complete before placing order.

Revision History

Rev.	Date	Change Notice
01	05/10/2006	Original Specification.