

## High Voltage Green-Mode PWM Controller with Over Temperature Protection

Ver. 00

### General Description

The LD7578H integrated several functions of protections, and EMI-improved solution in a SOP-8/or DIP-8 package. It minimizes the component counts and the circuit space, and is perfect for the low-cost applications.

It provides functions of low startup current, green-mode power-saving operation, leading-edge blanking of the current sensing and internal slope compensation. Also, the LD7578H features more protections like OLP (Over Load Protection), OVP (Over Voltage Protection), and OTP (Over Temperature Protection) to prevent the circuit being damaged from the abnormal conditions.

Furthermore, the LD7578H features frequency trembling to suppress the noise, providing an excellent solution for EMI filter design.

### Features

- High-Voltage (500V) Startup Circuit
- Current Mode Control
- Non-Audible-Noise Green Mode Control
- UVLO (Under Voltage Lockout)
- Leading-Edge Blanking
- Internal Trembling ( $\pm 4\text{KHz}$ )
- Internal Slope Compensation
- Internal Over Current Protection
- OVP on Vcc/Latch Mode
- OLP /Latch Mode
- External OTP through a NTC
- 500mA Driving Capability

### Applications

- Switching AC/DC Adaptor and Battery Charger
- Open Frame Switching Power Supply

### Typical Application

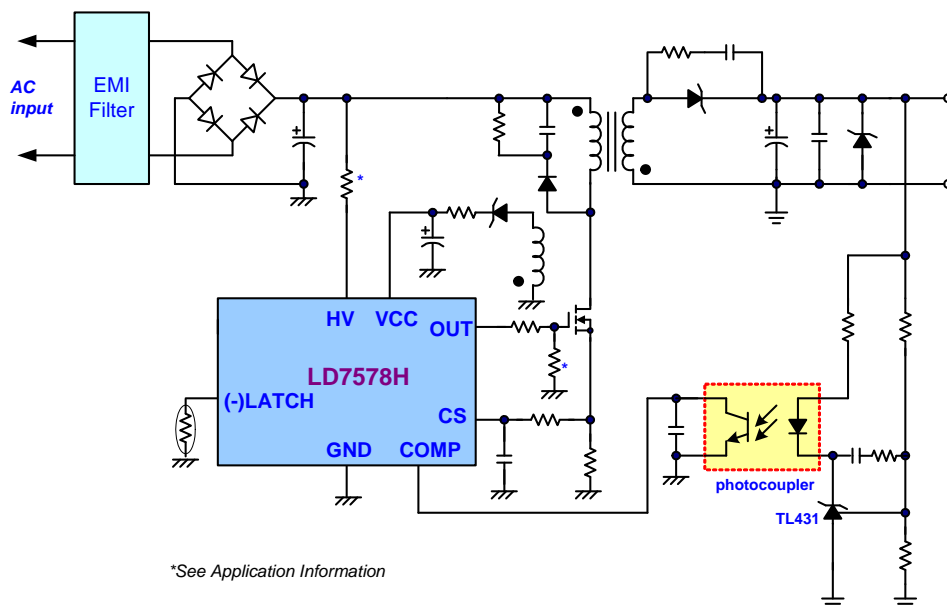

## Pin Configuration

SOP-8 & DIP-8 (TOP VIEW)

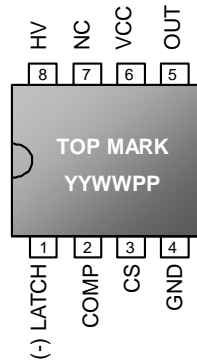

YY: Year code  
 WW: Week code  
 PP: Production code

## Ordering Information

Part number	Protection Mode OLP/OVP	Package		Top Mark	Shipping
LD7578HGS	Latch	SOP-8	Green	LD7578HGS	2500 /tape & reel
LD7578HGN	Latch	DIP-8	Green	LD7578HGN	3600 /tube /Carton

The LD7578H is ROHS compliance.

## Pin Descriptions

PIN	NAME	FUNCTION
1	(-) LATCH	Pulling this pin below 0.95V will shutdown the controller to enter latch mode until the AC power-on recycles. By connecting a NTC between this pin and ground will achieve OTP protection function. Let this pin float to disable the latch protection.
2	COMP	Voltage feedback pin (same as the COMP pin in UC384X). Connecting a photo-coupler will close the control loop and achieve the regulation.
3	CS	Current sense pin. Connect it to sense MOSFET current
4	GND	Ground
5	OUT	Gate drive output to drive the external MOSFET
6	VCC	Supply voltage pin
7	NC	Unconnected Pin
8	HV	Connect this pin to positive terminal of bulk capacitor to provide the startup current for the controller. When Vcc voltage trips the UVLO(on), this HV loop will be shut off to reduce power loss from the startup circuit.

## Block Diagram

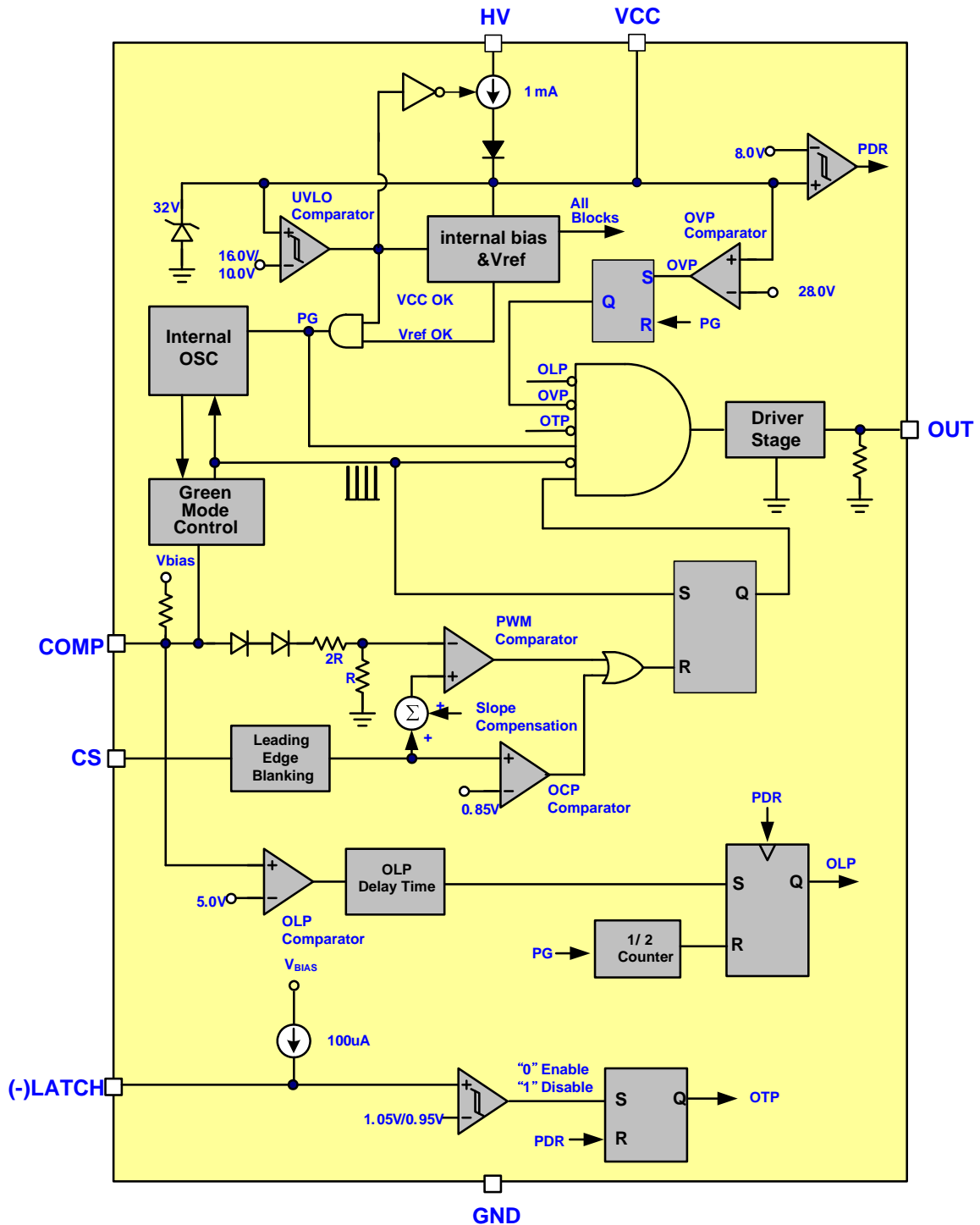

## Absolute Maximum Ratings

Supply Voltage VCC .....	-0.3V~30V
High-Voltage Pin, HV.....	-0.3V~500V
COMP, (-)LATCH, CS.....	-0.3V~7V
OUT.....	-0.3V~Vcc+0.3
Maximum Junction Temperature.....	150°C
Operating Ambient Temperature Range.....	-20°C to 85°C
Operating Junction Temperature Range.....	-40°C to 125°C
Storage Temperature Range .....	-65°C to 150°C
Package Thermal Resistance (SOP-8).....	160°C/W
Package Thermal Resistance (DIP-8).....	100°C/W
Power Dissipation (SOP-8, at Ambient Temperature = 85°C).....	400mW
Power Dissipation (DIP-8, at Ambient Temperature = 85°C).....	650mW
Lead temperature (Soldering, 10sec).....	260°C
ESD Voltage Protection, Human Body Model (except HV Pin).....	2.5KV
ESD Voltage Protection, Machine Model.....	250V
Gate Output Current.....	500mA

### Caution:

Stresses beyond the ratings specified in "Absolute Maximum Ratings" may cause permanent damage to the device. This is a stress only rating and operation of the device at these or any other conditions above those indicated in the operational sections of this specification is not implied.

## Electrical Characteristics

(T<sub>A</sub> = +25°C unless otherwise stated, V<sub>CC</sub>=15.0V)

PARAMETER	CONDITIONS	MIN	TYP	MAX	UNITS
<b>High-Voltage Supply (HV Pin)</b>					
High-Voltage Current Source	V <sub>CC</sub> < UVLO(on), HV=500V	0.5	1.0	1.5	mA
Off-State Leakage Current	V <sub>CC</sub> > UVLO(off), HV=500V	-	-	35	μA
<b>Supply Voltage (Vcc Pin)</b>					
Startup Current	V <sub>CC</sub> =UVLO(off)	-	320	-	μA
Operating Current (with 1nF load on OUT pin)	V <sub>COMP</sub> =0V, F <sub>sw</sub> =65KHz	-	3.3	3.8	mA
	V <sub>COMP</sub> =3V, F <sub>sw</sub> =65KHz	-	3.3	3.9	mA
	OLP tripped, Latch	-	0.78	-	mA
	OVP tripped, Latch	-	0.75	-	mA
	(-)-Latch Pin Tripped	-	2.5	-	mA
UVLO (off)		9.0	10.0	11.0	V
UVLO (on)		15.0	16.0	17.0	V
OVP Level		26.5	28.0	29.5	V
<b>Voltage Feedback (Comp Pin)</b>					
Short Circuit Current	V <sub>COMP</sub> =0V	-	1.5	2.2	mA
Open Loop Voltage	COMP pin open	-	5.8	-	V
Fixed Frequency Mode Threshold V <sub>comp</sub>		-	2.7	-	V
Green Mode Threshold V <sub>COMP</sub>		-	2.15	-	V
Burst Mode Threshold V <sub>comp</sub>		-	1.4	-	V
<b>Current Sensing (CS Pin)</b>					
Maximum Input Voltage, V <sub>cs_off</sub>		0.80	0.85	0.90	V
Maximum Input Voltage, V <sub>cs_min</sub>		-	0.73	-	V
Leading Edge Blanking Time	V <sub>COMP</sub> >1.9V	-	250	-	nS
Leading Edge Blanking Time	V <sub>COMP</sub> <1.9V	-	1700	-	nS
Input impedance		1	-	-	MΩ
Delay to Output		-	100	-	nS
<b>Oscillator for Switching Frequency</b>					
Frequency	65KHz	60.0	65.0	70.0	KHz
Green Mode Frequency	65KHz	-	22	-	KHz

## Electrical Characteristics

(T<sub>A</sub> = +25°C unless otherwise stated, V<sub>CC</sub>=15.0V)

PARAMETER	CONDITIONS	MIN	TYP	MAX	UNITS
<b>Oscillator for Switching Frequency</b>					
Trembling Frequency	65KHz	-	±4	-	KHz
Modulation Frequency	F <sub>sw</sub> =65KHz	-	86	-	Hz
Temp. Stability	(-20°C ~105°C)	-	5	-	%
Voltage Stability	(V <sub>CC</sub> =11V-25V)	-	1	-	%
<b>Latch Protection ((-)LATCH Pin)</b>					
(-)LATCH Pin Source Current		92	100	108	μA
Turn-On Trip Level		1.0	1.05	1.1	V
Turn-Off Trip Level		0.90	0.95	1.00	V
(-)LATCH pin de-bounce time		200	250	300	μS
De-latch Vcc Level	(PDR, Power Down Reset)	7.2	8.0	8.8	V
<b>Gate Drive Output (OUT Pin)</b>					
Output Low Level	V <sub>CC</sub> =15V, I <sub>o</sub> =20mA	-	-	1	V
Output High Level	V <sub>CC</sub> =15V, I <sub>o</sub> =20mA	9	-	-	V
Rising Time	Load Capacitance=1000pF	-	100	160	nS
Falling Time	Load Capacitance=1000pF	-	30	60	nS
<b>OLP (Over Load Protection)</b>					
OLP Trip Level	Latch	4.5	5.0	5.5	V
Delay Time	Latch	-	125	-	mS
De-latch Vcc Level	Latch(PDR)	7.2	8.0	8.8	V

## Typical Performance Characteristics

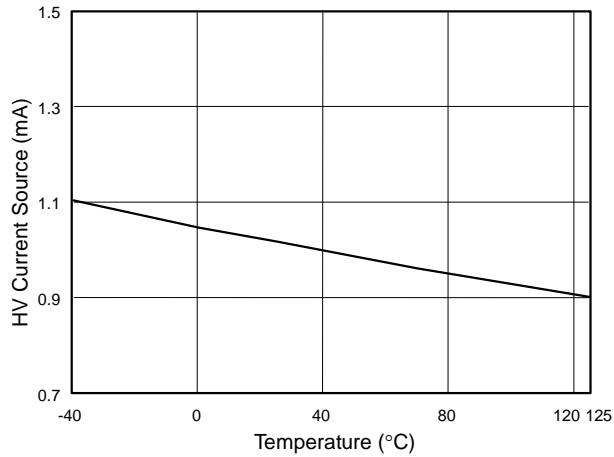

Fig. 1 HV Current Source vs. Temperature (HV=500V, Vcc=0V)

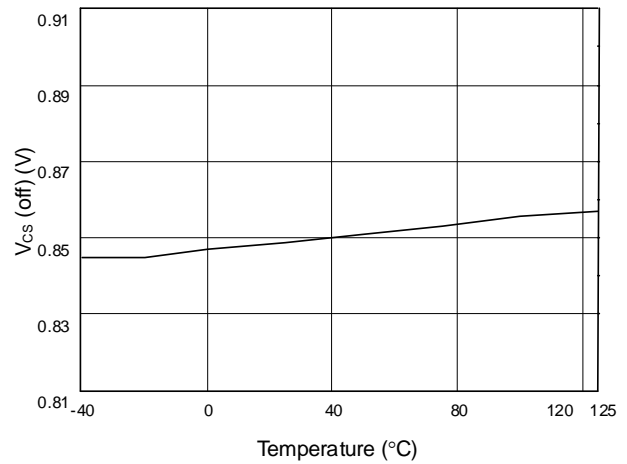

Fig. 2 Vcs (off) vs. Temperature

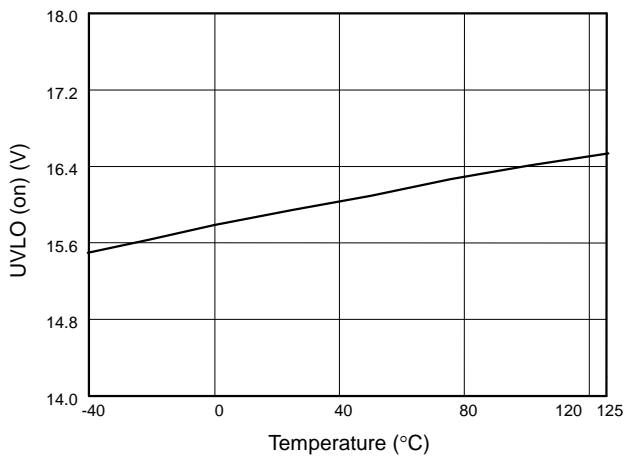

Fig. 3 UVLO (on) vs. Temperature

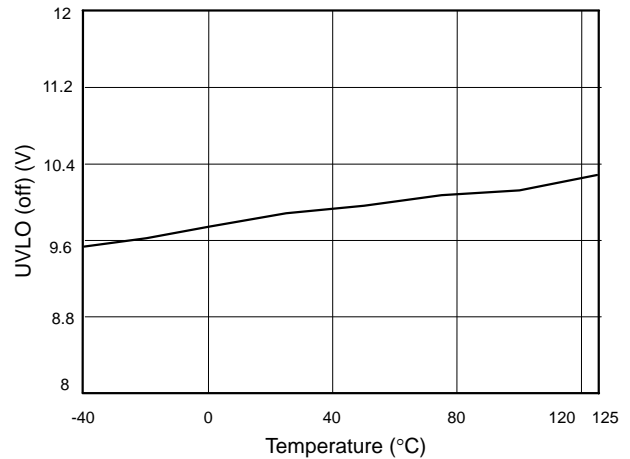

Fig. 4 UVLO (off) vs. Temperature

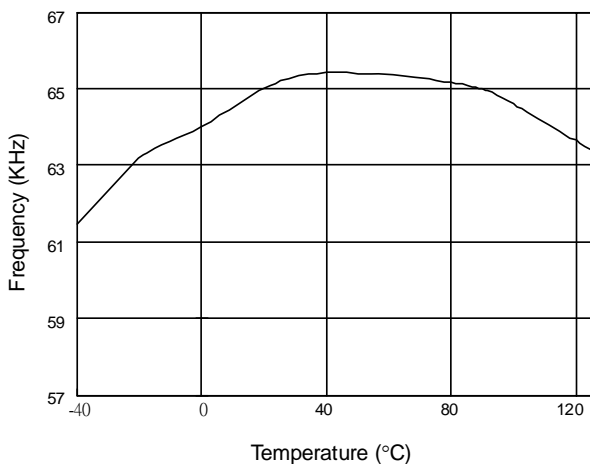

Fig. 5 Frequency vs. Temperature

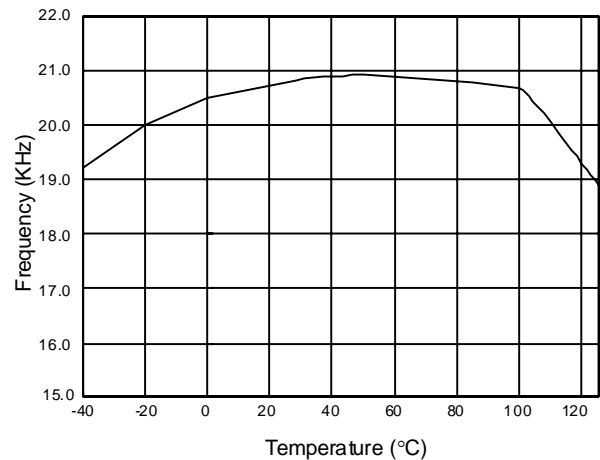

Fig. 6 Green Mode Frequency vs. Temperature

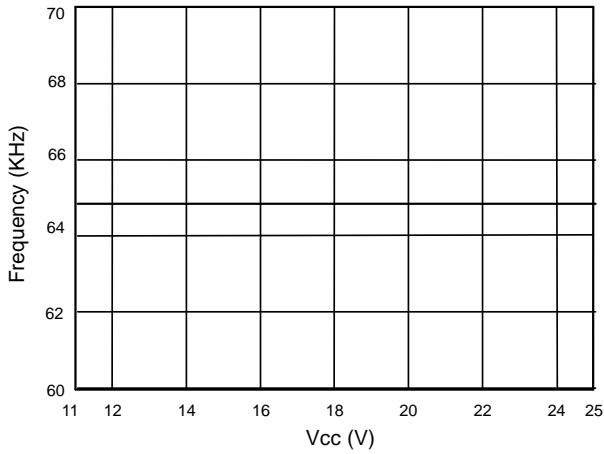

Fig. 7 Frequency vs. Vcc

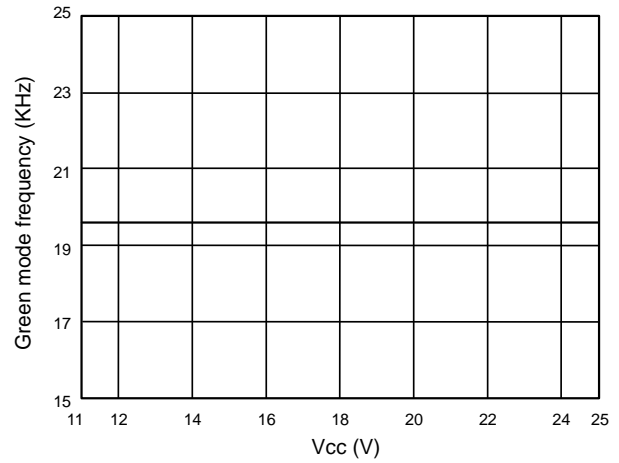

Fig. 8 Green mode frequency vs. Vcc

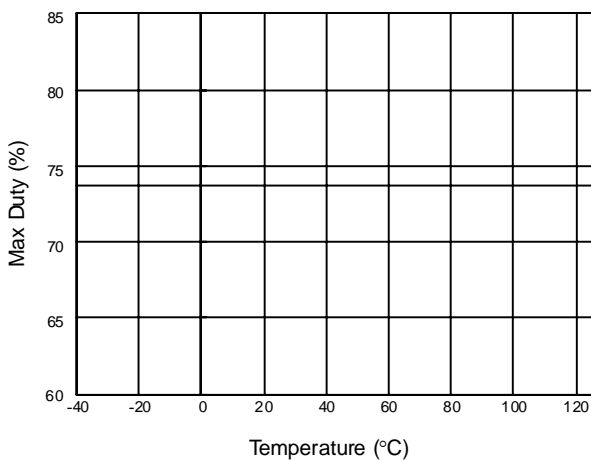

Fig. 9 Max Duty vs. Temperature

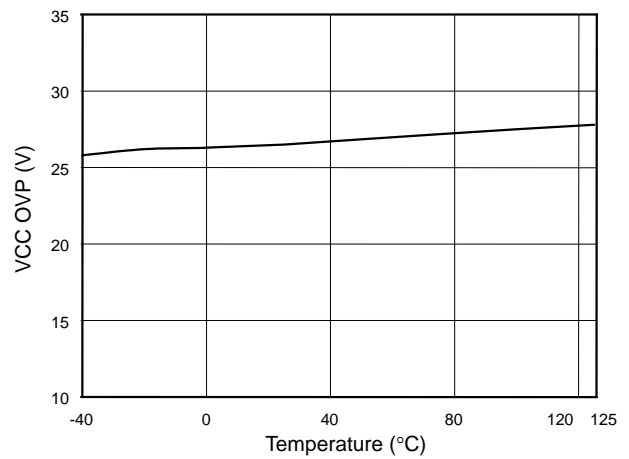

Fig. 10 VCC OVP vs. Temperature

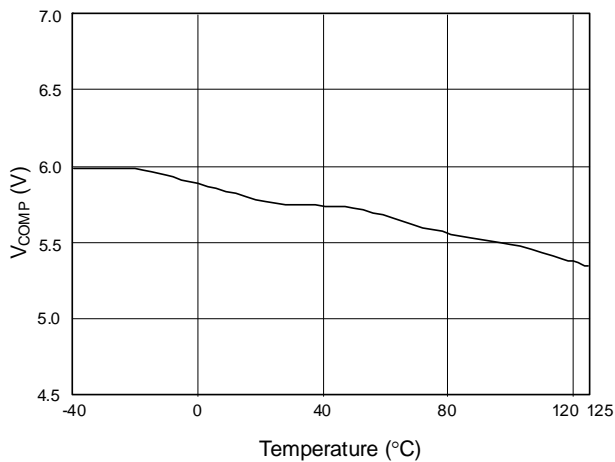

Fig. 11 V<sub>COMP</sub> open loop voltage vs. Temperature

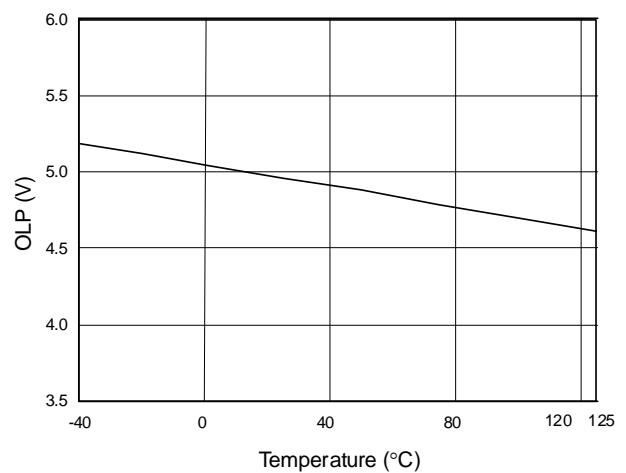

Fig. 12 OLP-Trip Level vs. Temperature



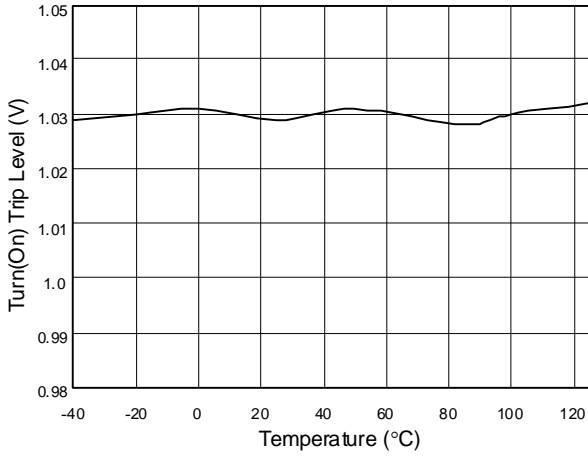

Fig. 13 Latch Pin Turn(On) Level vs. Temperature

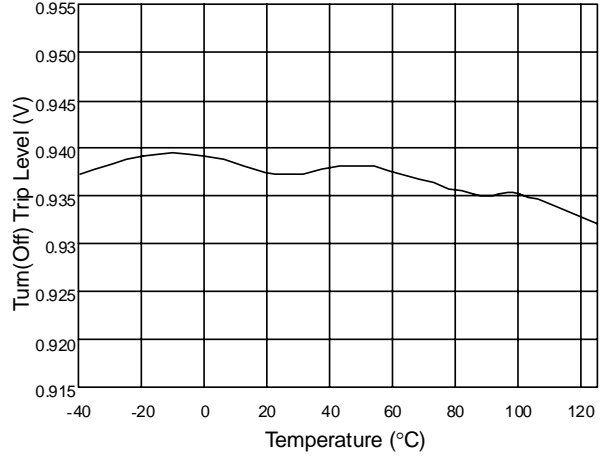

Fig. 14 Latch Pin Turn(Off) Level vs. Temperature

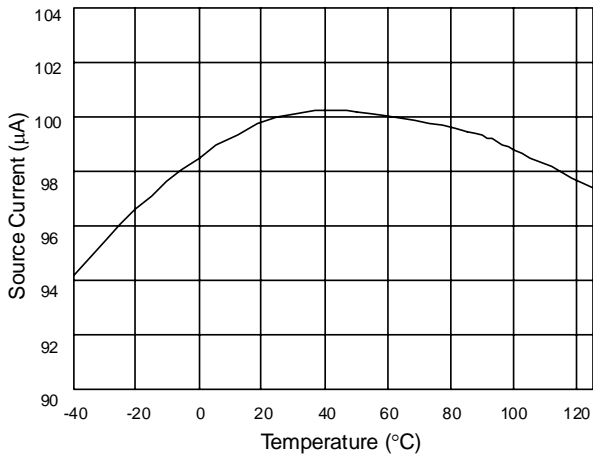

Fig. 15 (-) Latch Pin Source Current vs. Temperature

## Application Information

### Operation Overview

As long as the green power requirement becomes a trend and the power saving is getting more and more important for the switching power supplies and switching adaptors, the traditional PWM controllers are not able to support such new requirements. Furthermore, the cost and size limitations force PWM controllers to be more powerful by integrating more functions and, thus, reducing the external part count. The LD7578H designed for such application to provide an easy and cost effective solution. Its detail features are described as below:

### Internal High-Voltage Startup Circuit and Under Voltage Lockout (UVLO)

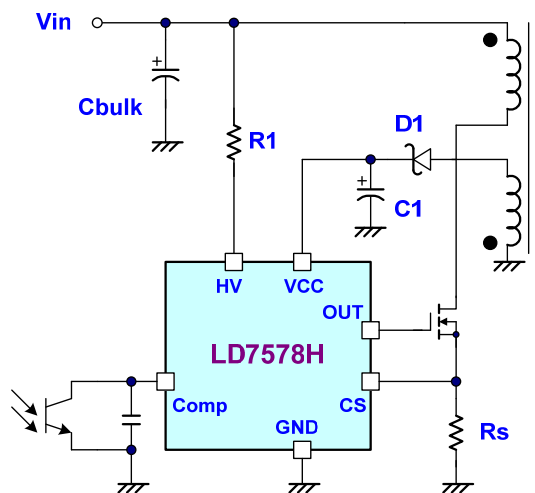

Fig. 13

Traditional circuit powers up the PWM controller through a startup resistor to constantly provide startup current. However, this startup resistor was usually of larger resistance, and it therefore required more power and longer time to start up. To achieve an optimized topology, as shown in figure 13, the LD7578H was built in with high voltage startup circuit to optimize the power saving. During the startup sequence, a high-voltage current source sinks current from Cbulk capacitor to provide the

startup current as well as to charge the Vcc capacitor C1. During the initialization of the startup, Vcc voltage is lower than the UVLO(off) threshold thus the current source is on to supply a current of 1mA. Meanwhile, the Vcc current consumed by LD7578H is as low as 300μA thus most of the HV current is utilized to charge the Vcc capacitor. By using such configuration, the turn-on delay time will be almost same no matter whether operation condition is under low-line or high-line.

When Vcc voltage reaches UVLO(on) threshold, LD7578H is powered on to start issuing the gate drive signal, the high-voltage current source is then disabled, and the supply current will be only provided from the auxiliary winding of the transformer. Therefore, the power losses on the startup circuit beyond the startup period can be eliminated and the power saving can be easily achieved.

An UVLO comparator is included to detect the voltage on the VCC pin to ensure the supply voltage is high enough to power on the LD7578H PWM controller and in addition to drive the power MOSFET. As shown in Fig. 14, a hysteresis is provided to prevent the shutdown caused by the voltage dip during startup. The turn-on and turn-off threshold levels are set at 16V and 10.0V, respectively.

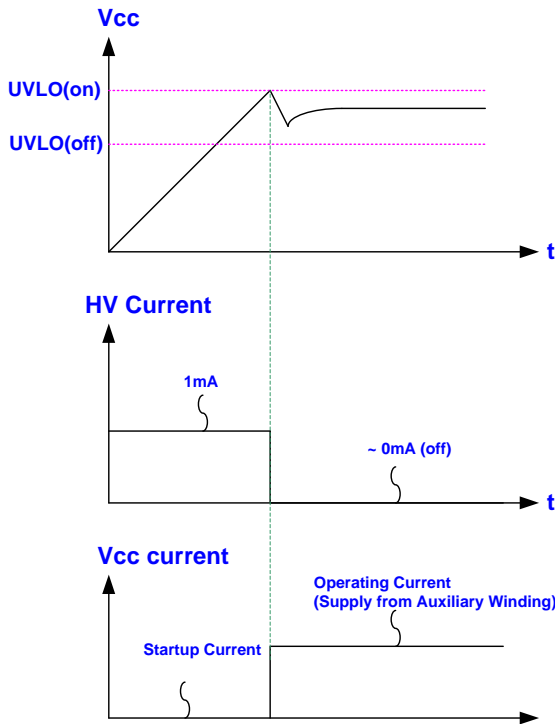

Fig. 14

## Current Sensing, Leading-edge Blanking and the Negative Spike on CS Pin

The typical current mode PWM controller feeds back both current signal and voltage signal to close the control loop and to achieve voltage regulation. The LD7578H detects the primary MOSFET current from the CS pin, which is applied not only for the peak current mode control but also for the pulse-by-pulse current limit. The maximum voltage threshold of the current sensing pin is set as 0.85V. Thus the MOSFET peak current can be calculated as:

$$I_{PEAK(MAX)} = \frac{0.85V}{R_S}$$

A 250nS leading-edge blanking (LEB) time is incorporated in the input of CS pin to prevent the false-trigger caused by any current spike. For low power applications, if the total pulse width of each turn-on spike is less than 250nS and the negative spike on the CS pin is not as low as -0.3V, the R-C filter (as shown in Fig.15) can be eliminated.

However, the total pulse width of the turn-on spike is related to the output power, circuit design and PCB layout. Nevertheless, it is strongly recommended to remain a small R-C filter (as shown in Fig. 16) for higher power applications to avoid the CS pin being damaged by negative turn-on spikes.

## Output Stage and Maximum Duty-Cycle

An output stage of a CMOS buffer, with typical 500mA driving capability, is incorporated to drive a power MOSFET directly. And the maximum duty-cycle of LD7578H is limited to 75% to avoid the transformer saturation.

## Voltage Feedback Loop

The voltage feedback signal is issued from the TL431 in the secondary side through the photo-coupler to the COMP pin of LD7578H. The input stage of LD7578H, like the UC384X, is incorporated with 2 diodes voltage offset circuit and a voltage divider with 1/3 ratio. Therefore,

$$V_{+(PWM\ COMPARTOR)} = \frac{1}{3} \times (V_{COMP} - 2V_F)$$

A pull-high resistor is embedded internally thus can be eliminated on the external circuit.

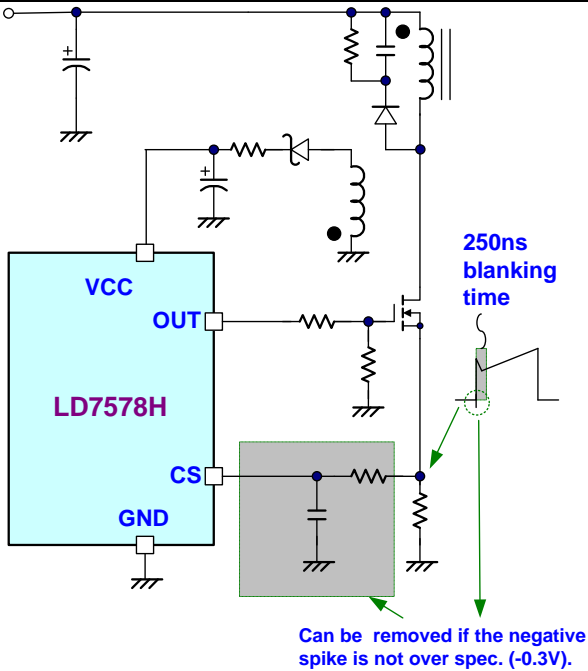

Fig. 15

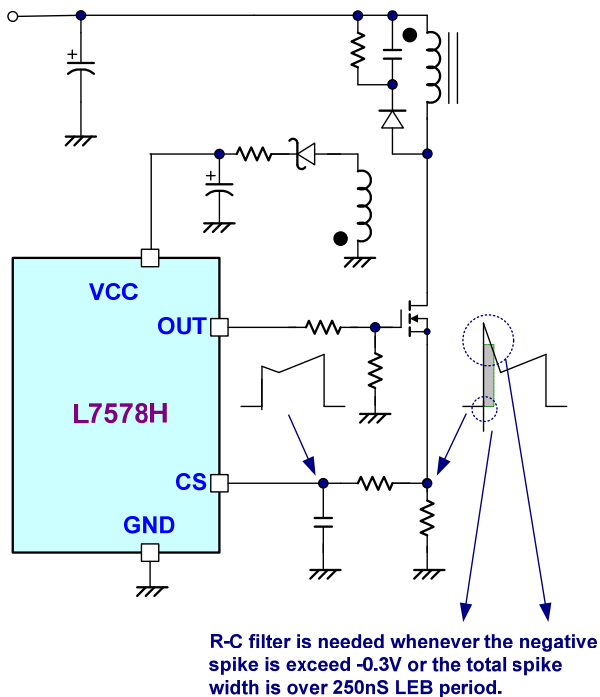

Fig. 16

## Oscillator and Switching Frequency

The switching frequency of LD7578H is fixed at 65KHz internally to provide the optimized operations by

considering the EMI performance, thermal treatment, component sizes and transformer design.

## Frequency Trembling

The LD7578H is implemented with adjustable frequency trembling function, providing the power supply designers with optimized EMI performance and lowest cost system solution. The Trembling frequency is fixed internally between  $\pm 4\text{KHz}$  to incorporate with the 65KHz switching frequency.

## Internal Slope Compensation

Stability is crucial for current mode control when it operates at more than 50% of duty-cycle. To stabilize the control loop, the slope compensation is required in the traditional UC384X design by injecting the ramp signal from the RT/CT pin through a coupling capacitor. In LD7578H, the internal slope compensation circuit has been implemented to simplify the external circuit design.

## On/Off Control

The LD7578H can be controlled to turn off by pulling COMP pin to lower than 1.2V. The gate output pin of LD7578H will be disabled immediately under such condition. The off mode can be released when the pull-low signal is removed.

## Dual-Oscillator Green-Mode Operation

There are many different topologies has been implemented in different chips for the green-mode or power saving requirements such as "burst-mode control", "skipping-cycle mode", "variable off-time control"...etc. The basic operation theory of all these approaches intended to reduce the switching cycles under light-load or no-load condition either by skipping some switching pulses or reduce the switching frequency.

What LD7578H use to implement the power-saving operation is Leadtrend Technology's own IP.

By using this dual-oscillator control, the green-mode frequency can be well controlled and further to avoid the generation of audible noise.

## Over Load Protection (OLP)

To protect the circuit from the damage during over load condition or short condition, a smart OLP function is implemented in the LD7578H. Figure 17 shows the waveforms of the OLP operation. Under such fault condition, the feedback system will force the voltage loop toward the saturation and then pulls the voltage of COMP pin to high. Whenever the VCOMP trips the OLP threshold 5.0V and continues over 125mS (when switching frequency is 65KHz), the protection is activated and then turns off the gate output to stop the switching of power circuit. The 125mS delay time is to prevent the false trigger from the power-on and turn-off transient. The over load protection is latch off mode. User should remove AC power source. The Vcc of LD7578H will drop down and de-latch until the Vcc of LD7578H lower than PDR level.

A divide-2 counter is implemented to reduce the average power under OLP behavior. Whenever OLP is activated, the output is latched off and the divide-2 counter starts to count the number of UVLO(off). The latch is released if the 2nd UVLO(off) point is counted then the output is recovery to switching again.

By using such protection mechanism, the average input power can be reduced to very low level so that the component temperature and stress can be controlled within the safe operating area.

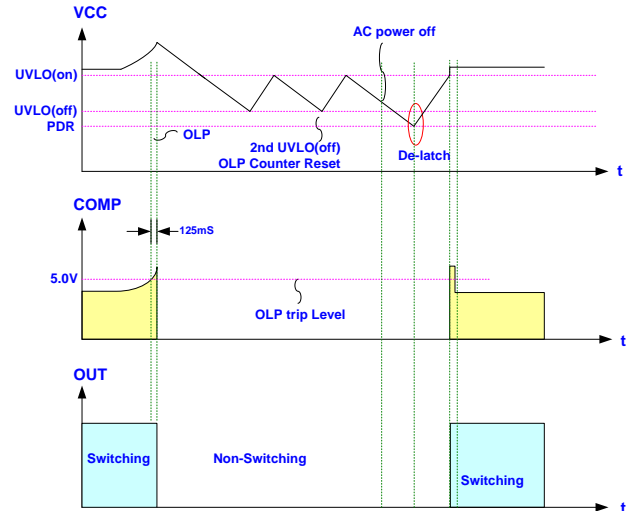

Fig. 17

## OVP (Over Voltage Protection) on Vcc

The  $V_{GS}$  ratings of the nowadays power MOSFETs are mostly with 30V maximum. To prevent the  $V_{GS}$  from fault condition, LD7578H is implemented with OVP function on Vcc. As long as the the Vcc voltage is higher than the OVP threshold voltage, the output gate drive circuit will be shutdown simultaneous thus to stop the switching of the power MOSFET until the next UVLO(ON).

The Vcc OVP function in LD7578H is latch off type protection. If the OVP condition, usually caused by the feedback loop opened, is tripped, the Vcc will not recover until AC power turn off . Figure 18 shows its operation. The Vcc of LD7578H will drop down due to AC power turn off. The de-latch level of OVP is determined by internal PDR. Over voltage protection could be released soon as Vcc is below PDR level.

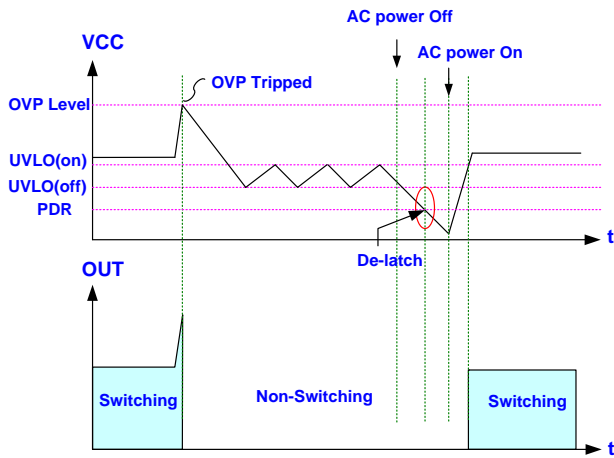

Fig. 18

## (-)LATCH Pin and Over Temperature Protection (OTP) --- Latched Mode Protection

Under some abnormal conditions, the ambient temperature may be increased significantly and cause some damage on the components or further inhibits the dangerous. To prevent damage due to system's malfunction, the OTP is required for the power circuit. The OTP circuit is implemented by sensing the hot-spot of power circuit like power MOSFET or output rectifier. It can be easily achieved by connecting a NTC on the (-)LATCH pin of LD7578H. As the device temperature or ambient temperature rises high enough, the resistance of NTC will decrease, so that the voltage on the (-)LATCH pin will be

$$V_{(-)Latch} = 100\mu A \cdot R_{NTC}$$

When the  $V_{(-)LATCH}$  falls below threshold voltage (typical 0.95V), LD7578H will shutdown the gate output and then latch-off the power supply. The controller will be kept latched unless  $V_{cc}$  drops below 8V (power down reset) and the fault condition is removed. So the gate output will remain off even the abnormal condition is released. It requires 2 terms to successfully re-start the circuit. One is to cool down the circuit till NTC resistance increases

and  $V_{(-)LATCH}$  rises above 1.05V. The alternative is to unplug AC power and start a new cycle of AC power-on. The detailed operation is depicted as figure 19.

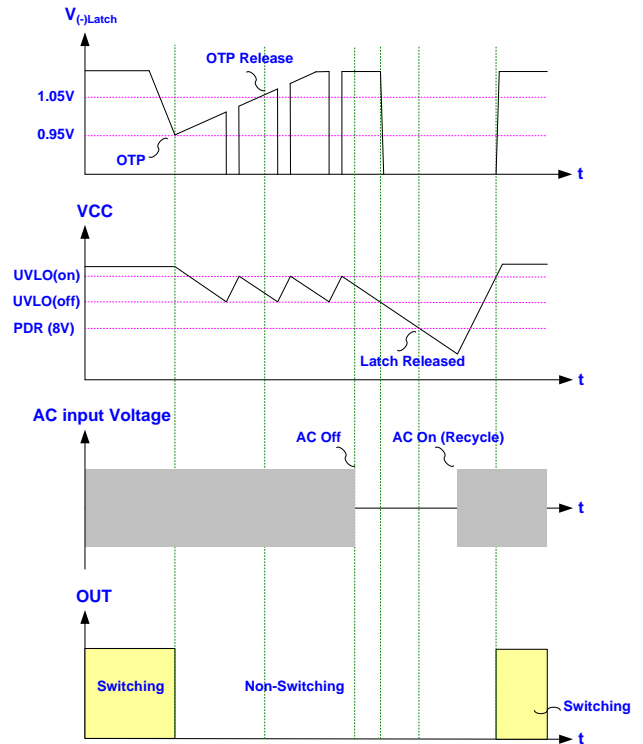

Fig. 19

## Pull-Low Resistor on the Gate Pin of MOSFET

An anti-floating resistor is implemented in the OUT pin to prevent any uncertain output, which may cause MOSFET working abnormally or false triggering-on. However, such design won't cover the conditions of disconnection of gate resistor  $R_G$ . It is still strongly recommended to have a resistor connected on the MOSFET gate terminal (as shown in figure 20) to provide extra protection for fault condition.

This external pull-low resistor is to prevent the MOSFET from being damaged during power-on when the gate resistor is disconnected. In such a single-fault condition, as shown in figure 21, the resistor R8 can provide a

discharge path to avoid the MOSFET from being false-triggered by the coupling through the gate-to-drain capacitor CGD. Therefore, the gate of MOSFET should be pulled low to maintain MOSFET in a off-state no matter the gate resistor is disconnected or opened in any case.

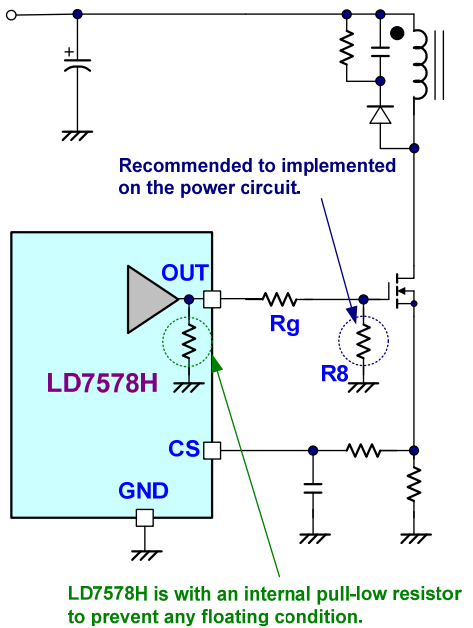

Fig. 20

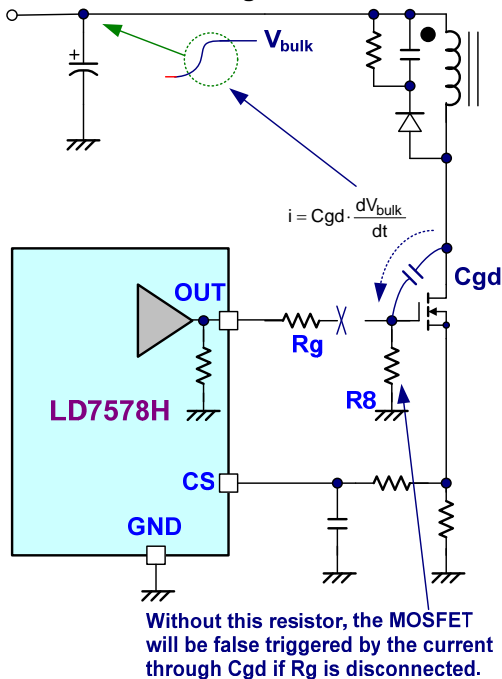

Fig. 21

### Protection Resistor on the Hi-V Path

In some other Hi-V processes and designs, there is probably some parasitic SCR caused around HV pin, V<sub>CC</sub> and GND. As shown in figure 22, a small negative spike in the HV pin may trigger this parasitic SCR and cause the latchup between V<sub>CC</sub> and GND. Such latchup will damage the chip easily because of the equivalent short-circuit induced.

LD7578H has eliminated the parasitic SCR efficiently. Figure 23 shows the equivalent circuit of LD7578H's Hi-V structure. It tells LD7578H is capable to sustain negative voltage and superior than similar products. Even though, a 40KΩ resistor is still recommended to be placed on the Hi-V path

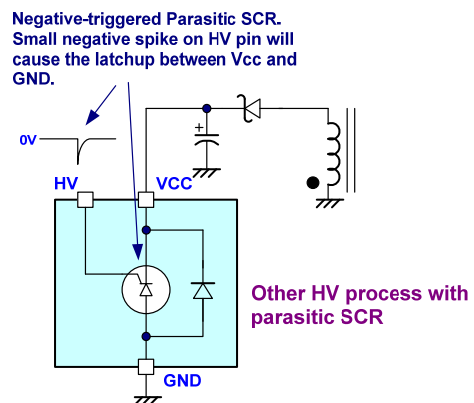

Fig. 22

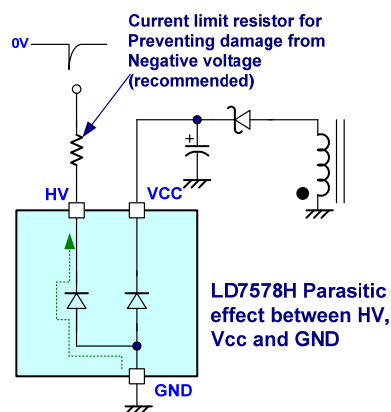
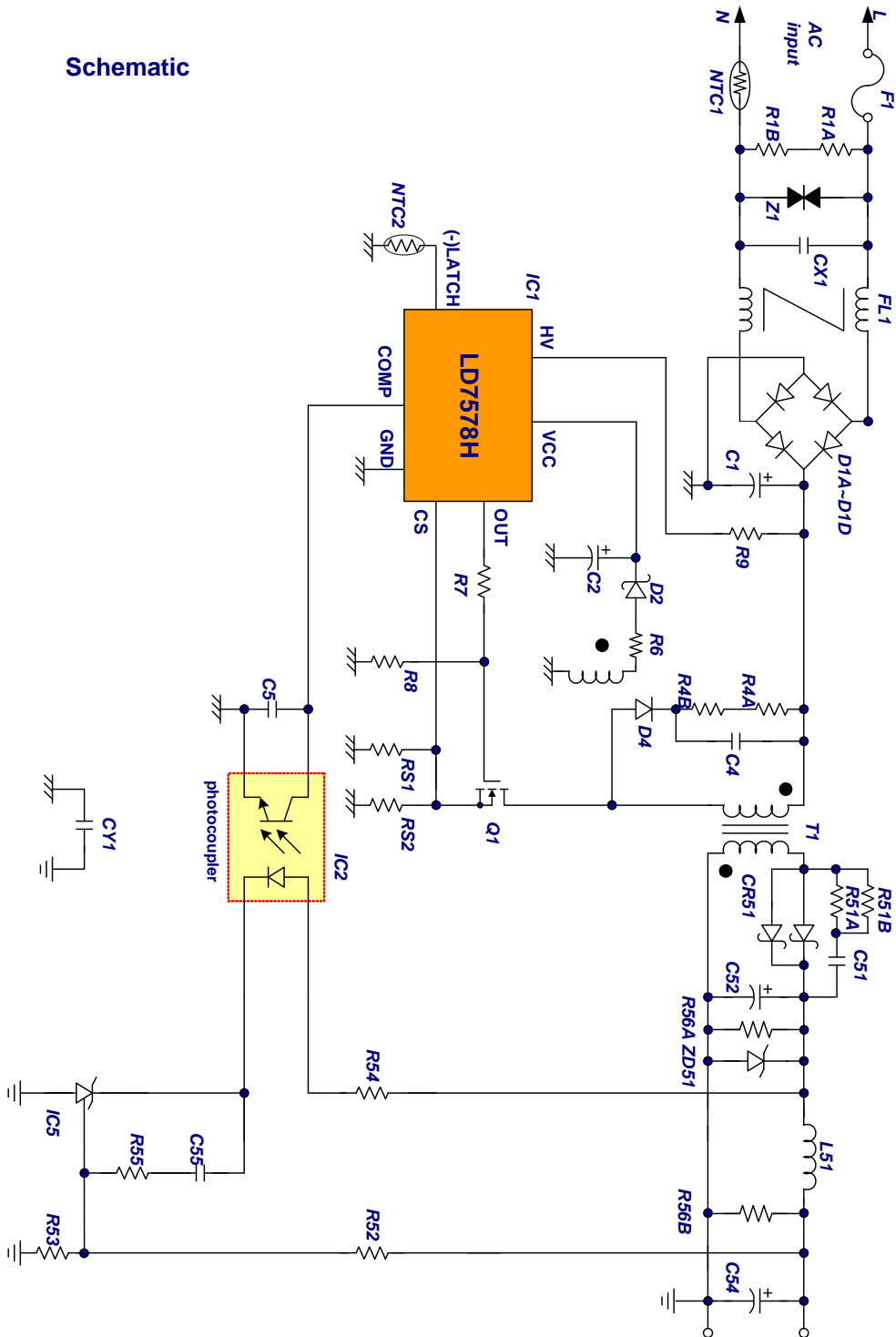

Fig. 23

## Reference Application Circuit --- 10W (5V/2A) Adapter

$P_{in} < 0.15W$  when  $P_{out} = 0W$  &  $V_{in} = 264Vac$

Schematic





## BOM

P/N	Component Value	Original
R1A	N/A	
R1B	N/A	
R4A	39K $\Omega$ , 1206	
R4B	39K $\Omega$ , 1206	
R6	2.2 $\Omega$ , 1206	
R7	10 $\Omega$ , 1206	
R8	10K $\Omega$ , 1206	
R9	40K $\Omega$ , 1206	
RS1	2.7 $\Omega$ , 1206, 1%	
RS2	2.7 $\Omega$ , 1206, 1%	
RT	100K $\Omega$ , 0805, 1%	
R51A	100 $\Omega$ , 1206	
R51B	100 $\Omega$ , 1206	
R52	2.49K $\Omega$ , 0805, 1%	
R53	2.49K $\Omega$ , 0805, 1%	
R54	100 $\Omega$ , 0805	
R55	1K $\Omega$ , 0805	
R56A	2.7K $\Omega$ , 1206	
R56B	N/A	
NTC1	5 $\Omega$ , 3A	08SP005
FL1	20mH	UU9.8
T1	EI-22	
L51	2.7 $\mu$ H	

P/N	Component Value	Note
C1	22 $\mu$ F, 400V	L-tec
C2	22 $\mu$ F, 50V	L-tec
C4	1000pF, 1000V, 1206	Holystone
C5	0.01 $\mu$ F, 16V, 0805	
C51	1000pF, 50V, 0805	
C52	1000 $\mu$ F, 10V	L-tec
C54	470 $\mu$ F, 10V	L-tec
C55	0.022 $\mu$ F, 16V, 0805	
CX1	0.1 $\mu$ F	X-cap
CY1	2200pF	Y-cap
D1A	1N4007	
D1B	1N4007	
D1C	1N4007	
D1D	1N4007	
D2	PS102R	
D4	1N4007	
Q1	2N60B	600V, 2A
CR51	SB540	
ZD51	6V2C	
IC1	LD7578HGS	SOP-8
IC2	EL817B	
IC51	TL431	1%
F1	250V, 1A	
Z1	N/A	

## Package Information

SOP-8

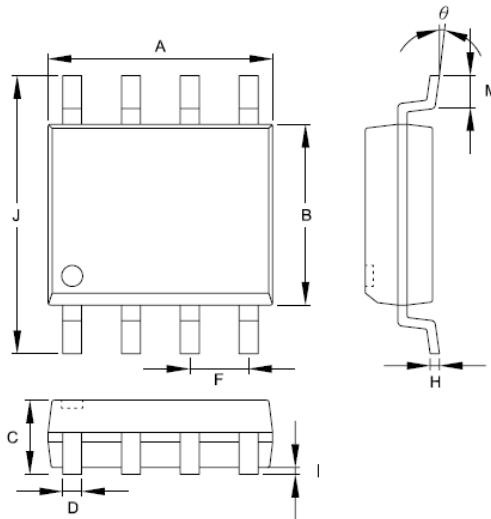

Symbols	Dimensions in Millimeters		Dimensions in Inch	
	MIN	MAX	MIN	MAX
A	4.801	5.004	0.189	0.197
B	3.810	3.988	0.150	0.157
C	1.346	1.753	0.053	0.069
D	0.330	0.508	0.013	0.020
F	1.194	1.346	0.047	0.053
H	0.178	0.229	0.007	0.009
I	0.102	0.254	0.004	0.010
J	5.791	6.198	0.228	0.244
M	0.406	1.270	0.016	0.050
$\theta$	0°	8°	0°	8°

## Package Information

DIP-8

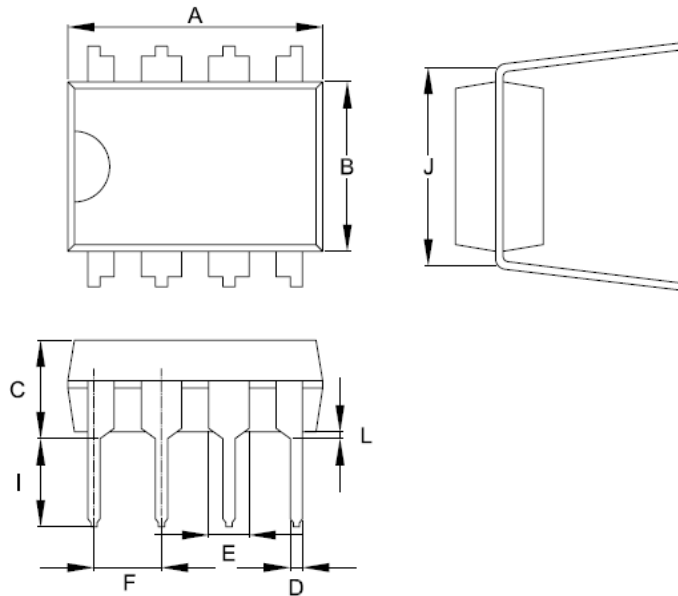

Symbol	Dimension in Millimeters		Dimensions in Inches	
	Min	Max	Min	Max
A	9.017	10.160	0.355	0.400
B	6.096	7.112	0.240	0.280
C	-----	5.334	-----	0.210
D	0.356	0.584	0.014	0.023
E	1.143	1.778	0.045	0.070
F	2.337	2.743	0.092	0.108
I	2.921	3.556	0.115	0.140
J	7.366	8.255	0.29	0.325
L	0.381	-----	0.015	-----

### Important Notice

Leadtrend Technology Corp. reserves the right to make changes or corrections to its products at any time without notice. Customers should verify the datasheets are current and complete before placing order.

**Revision History**

Rev.	Date	Change Notice
00	2/22/2010	Original Specification