

Non-isolation Buck Solution High Power Factor LED Controller

REV: 00

General Description

The LD7835D is a floating switch buck solution with Active PFC (APFC) control for LED lighting. It is easy to design with minimum cost and PCB size. The device operates in transition mode (TM) and integrates with complete safety requirement protections.

With power factor correction and TM control, the system is enabled to achieve high PF and high efficiency and to meet most of the international standard.

The LD7835 also features LED open protection (ZCD OVP), LED short protection, over current protection (OCP), and over temperature protection (OTP). It makes the circuit designers easily to meet most of the safety requirements in either normal or abnormal test.

Features

- High Power Factor Controller Integrated
- High Efficiency Transition Mode Operation
- Good Accurate Current Regulation
- Current Ripple Reduction (CRR) Function
- Wide Range of UVLO
- Built in OVP on VCC pin
- LED Open Protection
- LED Short Protection
- OCP (Cycle by cycle current limit)
- OTP (Over Temperature Protection)
- 250mA-250mA Driving Capability

Applications

- LED Lamp · LED bulb Application

Typical Application

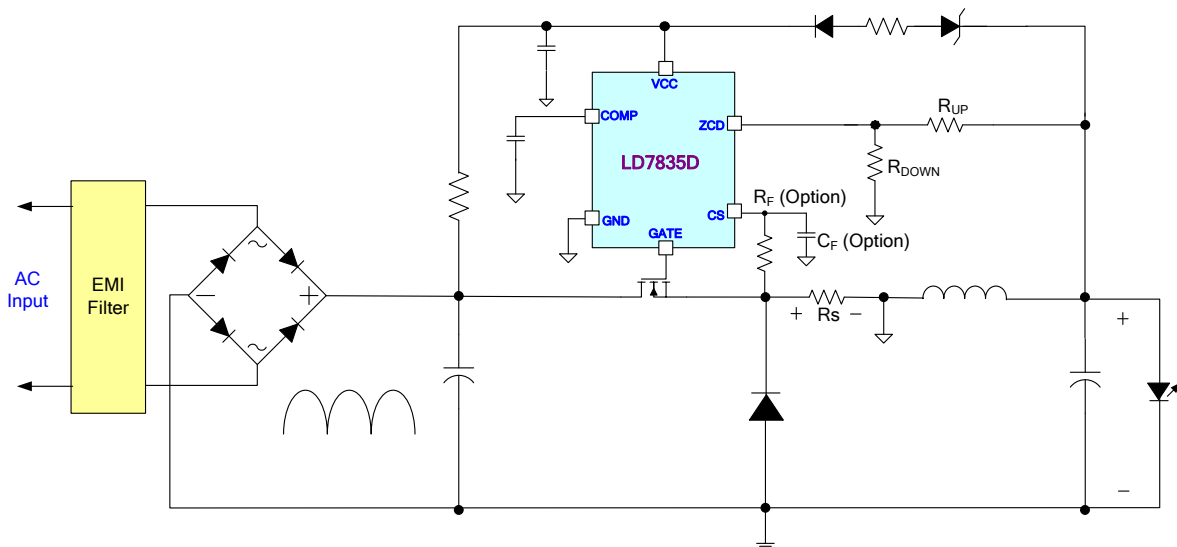
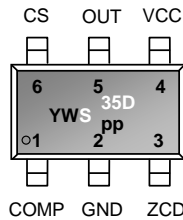

Fig. 1 Application circuit

Pin Configuration

SOT-26 (TOP VIEW)



YY, Y : Year code (D: 2004, E: 2005.....)
 WW, W : Week code
 PP : Production code
 S35D : LD7835D

Ordering Information

| Part number | Package | Top Mark | Shipping |
|-------------|---------|----------|-------------------|
| LD7835D GL | SOT-26 | YWS/35D | 3000 /tape & reel |

The LD7835D is ROHS compliant/ green packaged.

Protection Mode

| Part number | VCC_OVP | ZCD_OVP | OLP/ Output Short |
|-------------|---------------|---------------|----------------------|
| LD7835D | Auto recovery | Auto recovery | Auto recovery |

Pin Descriptions

| Pin | NAME | FUNCTION |
|-----|------|--|
| 1 | COMP | Compensation pin for internal error amplifier |
| 2 | GND | Ground |
| 3 | ZCD | Over voltage protection setting, Quasi resonance detector, support programmable maximum on-time. |
| 4 | VCC | Power Supply to VCC |
| 5 | OUT | Gate Signal Output |
| 6 | CS | Connecting a sense resistor to ground, support CRR function setting. |

Block Diagram

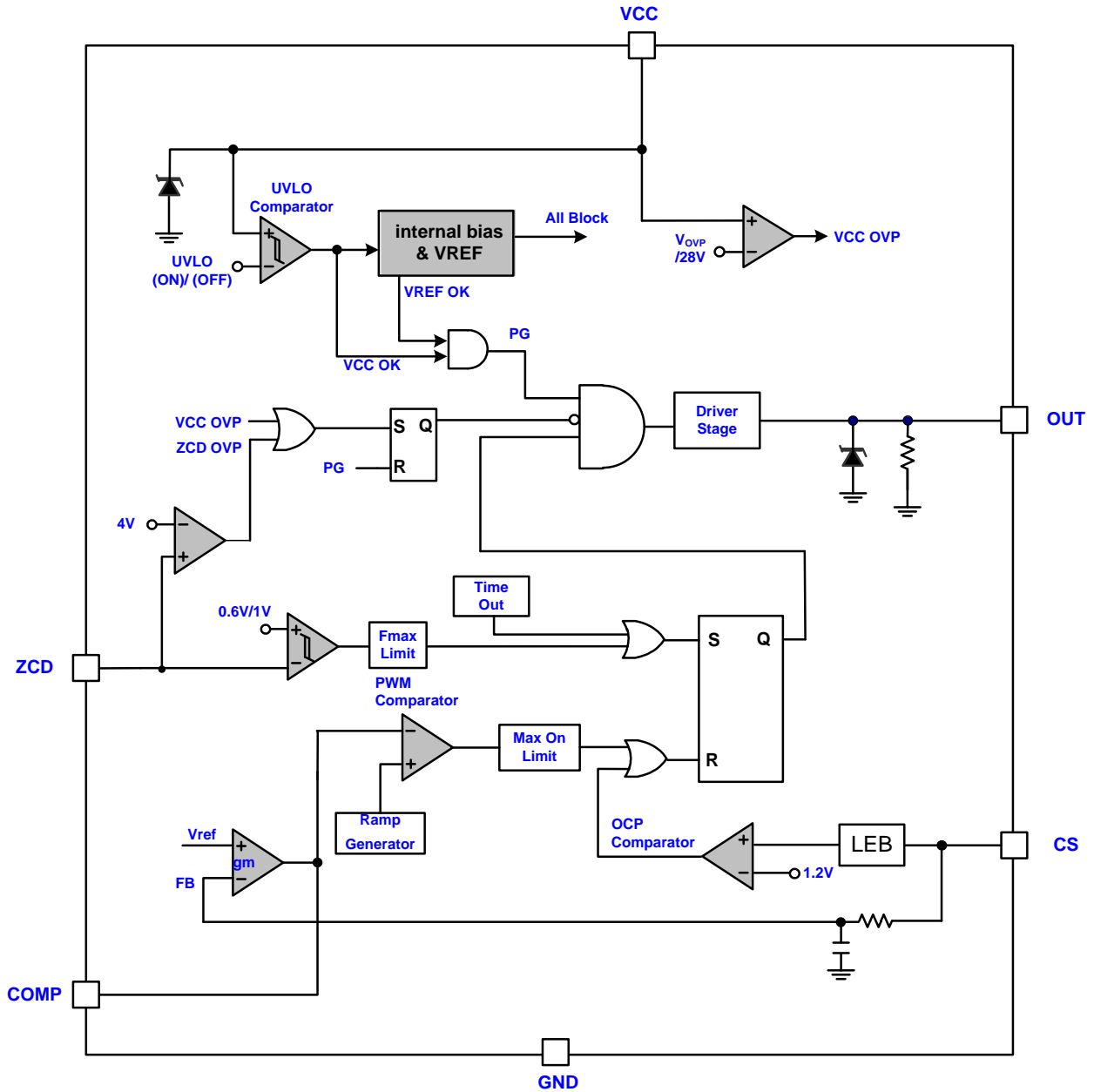

Absolute Maximum Ratings

| | |
|--|----------------|
| VCC..... | -0.3V ~ 30V |
| CS..... | -1V ~ 6V |
| ZCD..... | -0.3V ~ 6V |
| COMP..... | -0.3V ~ 6V |
| ZCD Source/ Sink Current..... | -2mA ~ 1mA |
| OUT..... | -0.3V ~ 30V |
| Maximum Junction Temperature..... | 150°C |
| Storage Temperature Range..... | -65°C to 150°C |
| Package Thermal Resistance (SOT-26, θ_{JA})..... | 200°C/W |
| Power Dissipation (SOT-26, $T_J=125^\circ\text{C}$, $T_A=85^\circ\text{C}$)..... | 200mW |
| Lead temperature (Soldering, 10sec)..... | 260°C |
| ESD Voltage Protection, Human Body Model..... | 2.5KV |
| ESD Voltage Protection, Machine Model..... | 250 V |

Caution:

Stress exceeding Maximum Ratings may damage the device. Maximum Ratings are stress ratings only. Functional operation above the Recommended Operating Conditions is not implied. Extended exposure to stress above Recommended Operating Conditions may affect device reliability.

Recommended Operating Conditions

| Item | Min. | Max. | Unit |
|--------------------------------------|------|------|---------------|
| VCC | 10 | 24 | V |
| VCC pin capacitor | 2.2 | 22 | μF |
| COMP voltage | 0.6 | 4.5 | V |
| COMP pin capacitor | 0.47 | 2.2 | μF |
| Operating Junction Temperature Range | -20 | 125 | °C |

Note:

1. It's essential to connect VCC pin with a SMD ceramic capacitor (0.1 μF ~0.47 μF) to filter out the undesired switching noise for stable operation. This capacitor should be placed close to IC pin as possible
2. Connecting a capacitor to COMP pin is also essential to filter out the undesired switching noise for stable operation.
3. The small signal components should be placed close to IC pin as possible.

Electrical Characteristics

(VCC = 14.0V, T_A = 25°C unless otherwise specified.)

| PARAMETER | CONDITIONS | Symbol | MIN | TYP | MAX | UNITS |
|---|----------------------------------|-----------------------|-------|------|-------|-------|
| Supply Voltage (VCC Pin) | | | | | | |
| Startup Current | VCC=10V | I _{VCC_ST} | - | - | 10 | μA |
| Operating Current (with 1nF load on OUT pin) | COMP=3V, ZCD=2V | I _{VCC_14} | - | 1 | - | mA |
| | Protection Tripped (OVP, OTP) | I _{VCC_PRO} | - | 2 | - | mA |
| UVLO (OFF) | | V _{UV_OFF} | 7.7 | 8.2 | 8.7 | V |
| UVLO (ON) | | V _{UV_ON} | 15 | 16 | 17 | V |
| VCC OVP Threshold | | V _{VCC_OVP} | 27 | 28 | 29 | V |
| Compensation (COMP Pin) | | | | | | |
| gm ⁽¹⁾ | | - | - | 200 | - | μA/V |
| COMP Pin Open Voltage | | V _{COMP} | 5 | 5.5 | 6 | V |
| Programmable Max-On Time | Level 1, COMP =5V | T _{ON_MAX1} | - | 15 | - | μs |
| | Level 2, COMP =5V | T _{ON_MAX2} | - | 21 | - | μs |
| | Level 3, COMP =5V | T _{ON_MAX3} | - | 29 | - | μs |
| Pre-charge voltage during soft-start ⁽¹⁾ | | V _{COMP_PRE} | - | 0.6 | - | V |
| Current Sensing (CS Pin) | | | | | | |
| Reference voltage | | V _{ref} | 0.194 | 0.2 | 0.206 | V |
| OCP Threshold (Cycle by Cycle) | | V _{OCP} | 1.1 | 1.2 | 1.3 | V |
| | During soft-start | V _{OCP_SS} | - | 0.45 | - | V |
| Soft-Start Time | | T _{SS} | 12 | 16 | 20 | ms |
| LEB time | | T _{LEB} | - | 250 | - | ns |
| Zero Current Detector (ZCD Pin) | | | | | | |
| Lower Clamp Voltage | | V _{ZCD_LC} | - | 0 | - | V |
| ZCD OVP Threshold | | V _{ZCD_OVP} | 3.8 | 4 | 4.2 | V |
| ZCD OVP Comparator De-bounce | | T _{DEB_OVP} | - | 1.6 | - | μs |
| Input Voltage Threshold | | V _{ZCD} | - | 0.6 | - | V |
| | Hysteresis | V _{ZCD_HYS} | - | 0.4 | - | V |
| ZCD Blanking Time | | T _{ZCD_BLK} | 1.5 | 2 | 2.5 | μs |
| Minimum (ON+OFF)-Time, F_{MAX} | | | | | | |
| Minimum ON+OFF-Time | F _{S, MAX} (150kHz) | T _{MIN} | 5.34 | 6.67 | 8 | μs |
| | During Soft-Start | T _{MIN_SS} | - | 11 | - | μs |

| PARAMETER | CONDITIONS | Symbol | MIN | TYP | MAX | UNITS |
|------------------------------------|-----------------------------------|---------------------|-----|-----|-----|-------|
| Gate Drive Output (OUT Pin) | | | | | | |
| Output Low Level | VCC=15V, I _{SINK} =20mA | V _{OUT_L} | - | - | 0.5 | V |
| Output High Level | VCC=15V, I _{SOURCE} =5mA | V _{OUT_H} | 8 | - | VCC | V |
| Output High Clamp Level | VCC=15V | V _{OUT_CL} | 12 | 13 | 14 | V |
| Rising Time ⁽¹⁾ | VCC=15V, CL=1nF | - | - | 120 | - | ns |
| Falling Time ⁽¹⁾ | VCC=15V, CL=1nF | - | - | 30 | - | ns |
| Time out | | | | | | |
| Time out Period during Soft start | | T _{OUT_SS} | - | 80 | - | μs |
| Time out Period after soft start | | T _{OUT} | 120 | 160 | 200 | μs |
| OTP (Over Temp. Protection) | | | | | | |
| OTP Trip level ⁽¹⁾ | | - | - | 140 | - | °C |
| OTP Hysteresis ⁽¹⁾ | | - | - | 30 | - | °C |

Note: ⁽¹⁾ Guaranteed by Design.

Typical Performance Characteristics

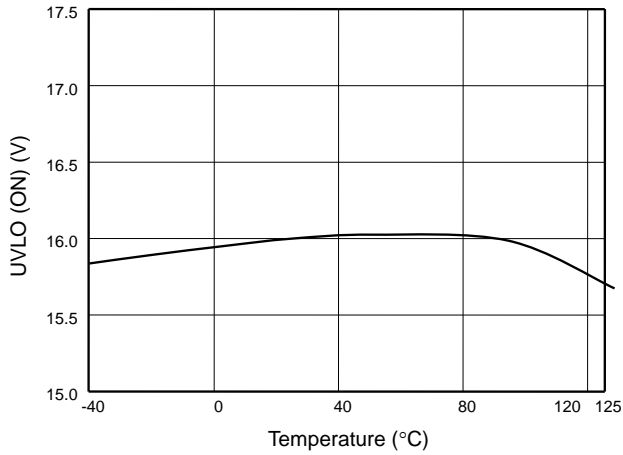

Fig. 2 UVLO (ON) vs. Temperature

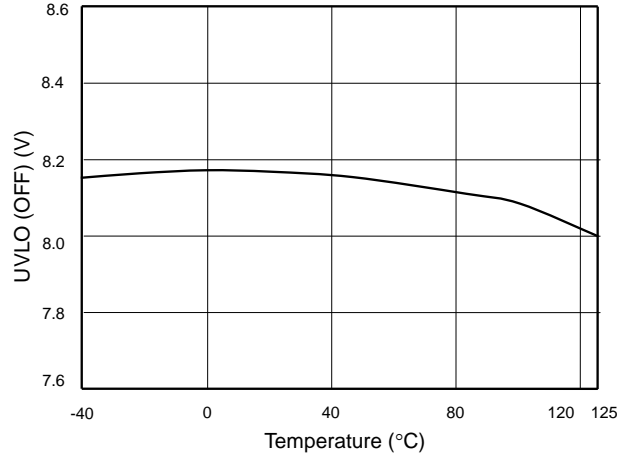

Fig. 3 UVLO (OFF) vs. Temperature

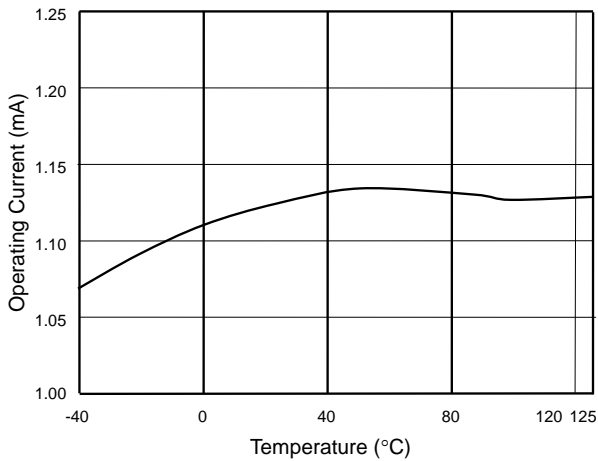

Fig. 4 Operating Current vs. Temperature

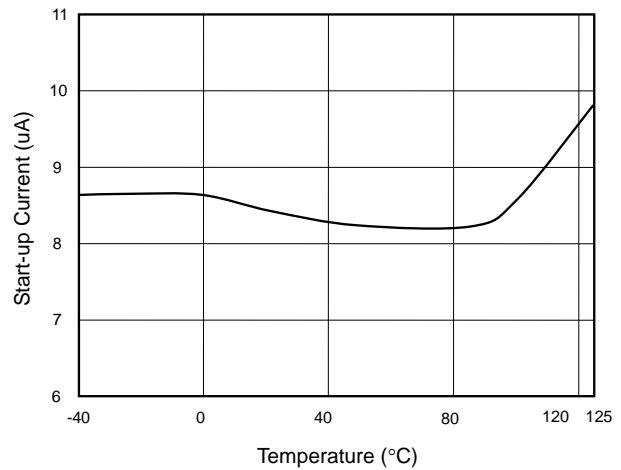

Fig. 5 Start-up Current vs. Temperature

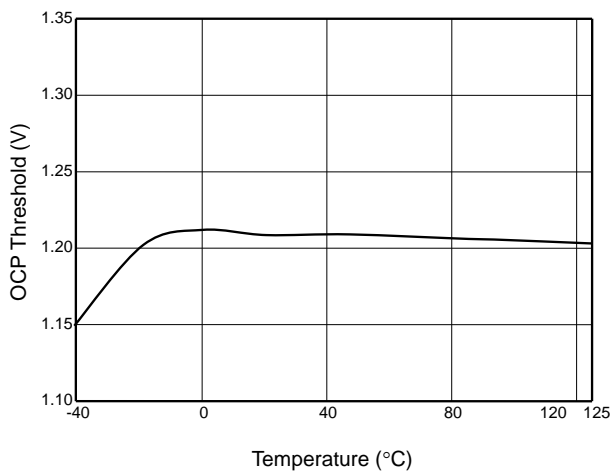

Fig. 6 OCP Threshold vs. Temperature

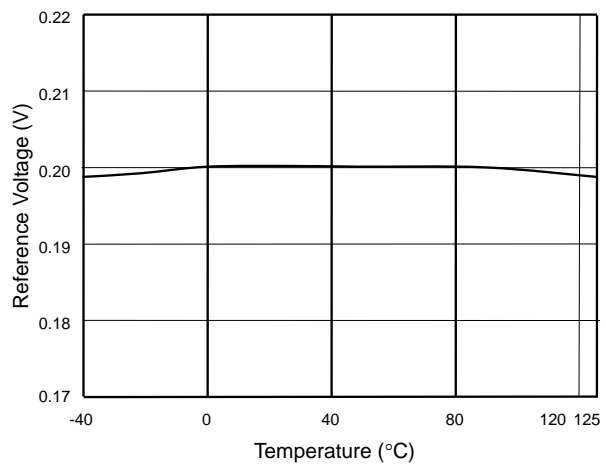

Fig. 7 Reference Voltage vs. Temperature

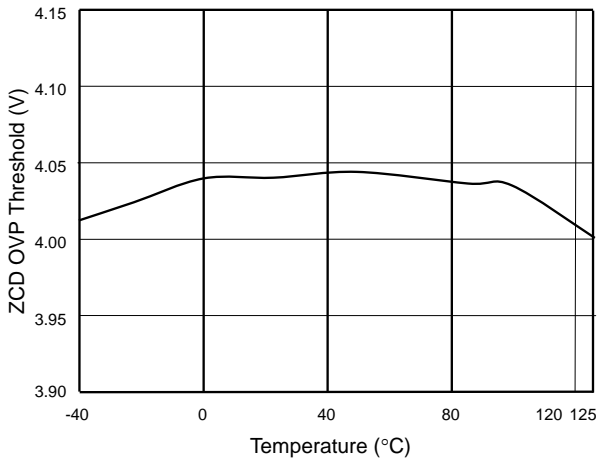

Fig. 8 ZCD OVP Threshold vs. Temperature

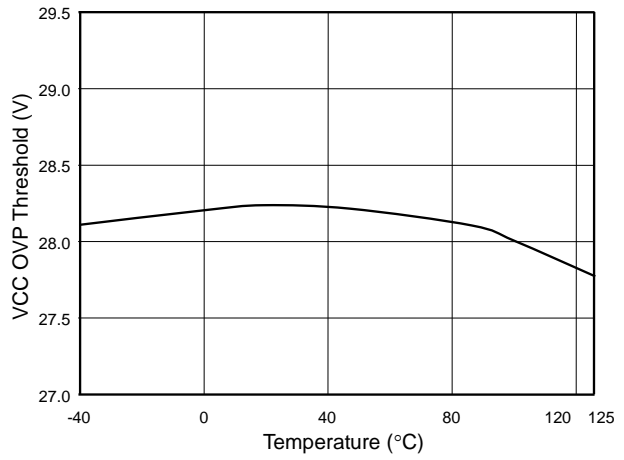

Fig. 9 VCC OVP Threshold vs. Temperature

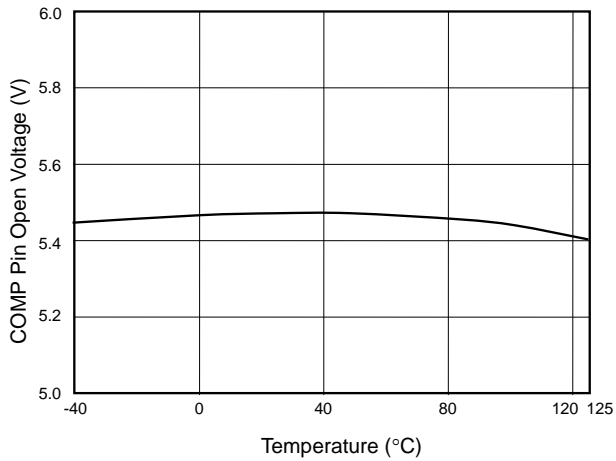

Fig. 10 COMP Pin Open Voltage vs. Temperature

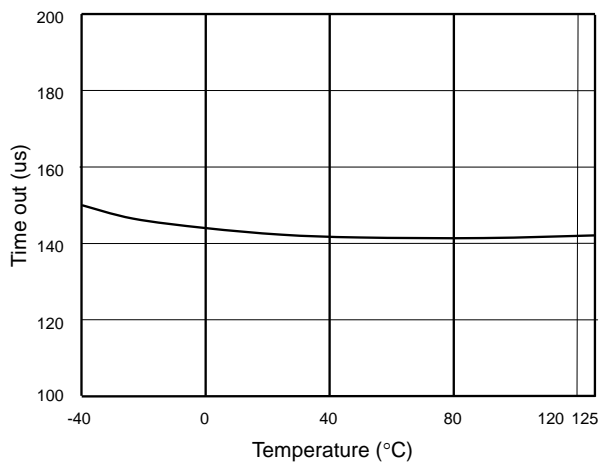

Fig. 11 Time out vs. Temperature

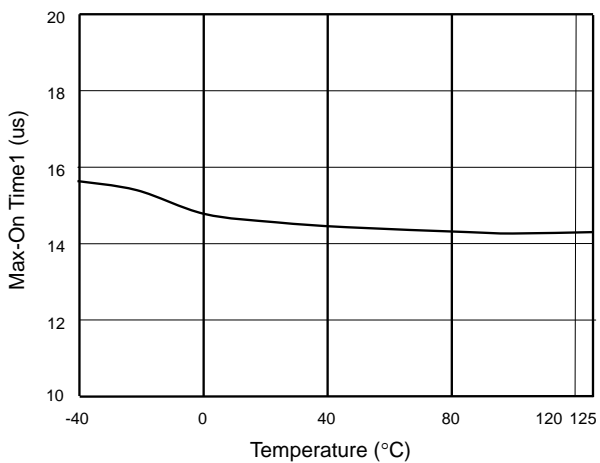

Fig. 12 Max-On Time1(COMP=5V) vs. Temperature

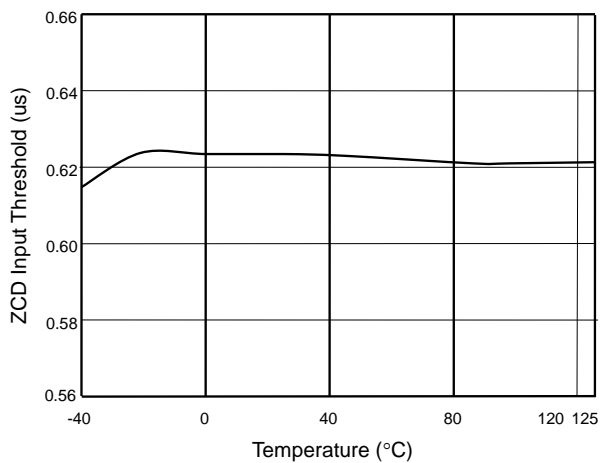

Fig. 13 ZCD Input Threshold vs. Temperature

Application Information

Operation Overview

LD7835D is an LED controller for lighting application. The transition mode (TM) technique meets the requirements for high power factor and high efficiency. It minimizes the external component counts and the PCB size for compact application.

The control mechanism of LD7835D is a voltage-mode operation. The switch turn-on time is fixed while the turn-off time varies in steady state. Therefore, the switch frequency changes in response to the different voltages. The affected frequency reduces EMI noise. LD7835D also features LED open protection, LED short protection, over current protection, and over temperature protection. No extra mains voltage sensing is required as what the traditional current mode PFC controllers behaves for power saving.

Ramp Generator Block, Zero Current Detection (ZCD) and ZCD OVP

Fig. 14 shows typical ramp generator block and ZCD block. The COMP pin voltage and the output of the ramp generator block are compared to determine the MOSFET On-time, as shown in Fig. 15.

The LD7835D features transition mode (TM) operation. The zero current detection block circuit detects the ZCD signal to turn on the MOSFET soon after the voltage across ZCD falls to 0.6V and also the current through the inductor reaches zero. Instead, if there's no signal detected within 160μs, the time-out will generate a signal to turn on MOSFET to ensure the system operate properly.

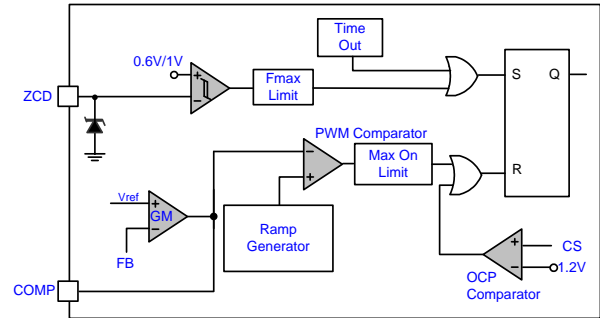

Fig. 14

During the delay time as shown in Fig. 15, the junction capacitor of the MOSFET resonates with the inductor and the drain-source voltage (VDS) decreases accordingly. So, the MOSFET consumes less voltage and the power dissipation will be minimized.

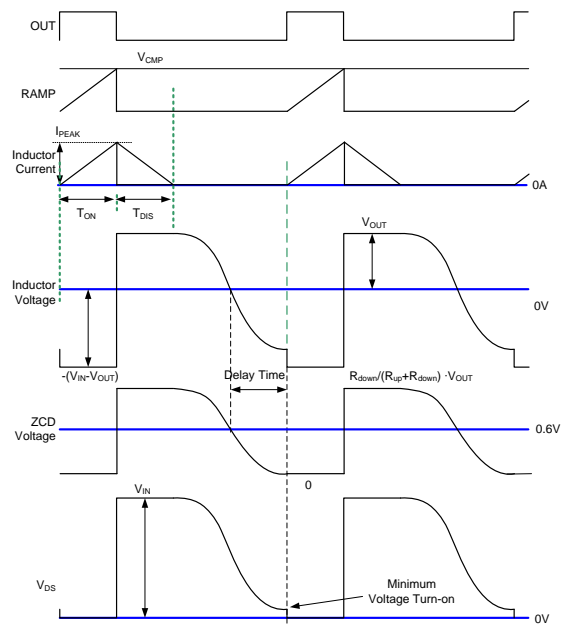

Fig. 15

Fig. 16 illustrates the operation of over voltage protection, where ZCD divider resistors continue to detect the output voltage as the gate switches in off state and return the information to ZCD. If the output voltage increases to trip the threshold, it will signal that there may be some LED(s) open. The LD7835D will then discharge VCC with a sourcing current (I_{CC_PRO}) till VCC drops to UVLO (OFF) level. LD7835D will shut down its operation until VCC rises up to next UVLO (ON)

level. If the open situation remains still, the system will enter to hiccup mode.

$$V_{ZCD_OVP} = V_{OVP} \times \frac{R_{DOWN}}{R_{UP} + R_{DOWN}}$$

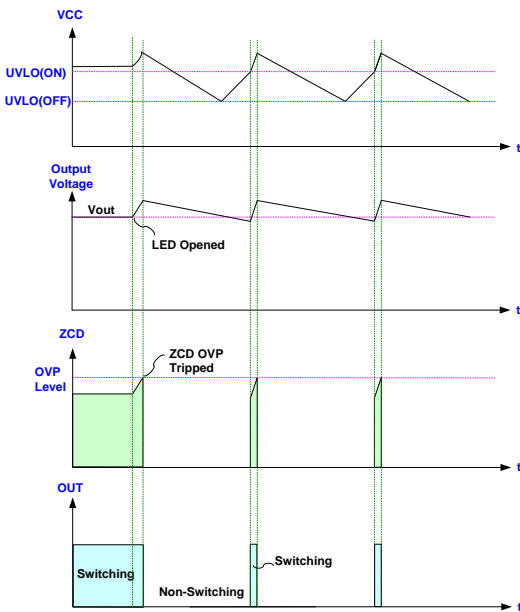
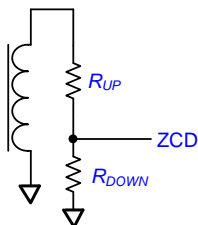

Fig. 16

Programming Maximum ON-time

LD7835D features adjustable maximum ON-time to limit power output in abnormal operation. The selection of maximum ON-time is subject to ZCD resistance as shown in Fig. 17. ZCD resistance can be obtained from below:



$$R_{ZCD} = \frac{R_{UP} \times R_{DOWN}}{R_{UP} + R_{DOWN}}$$

Fig. 17

The following table is a suggestion for maximum ON-time setting.

| R _{ZCD} (Ω) | Max. Ton (Typ.) | Suggestion (Ω) |
|------------------------------|--------------------|-------------------|
| 44k < R _{ZCD} | 15μs | 46k |
| 28k < R _{ZCD} < 32k | 21μs | 30k |
| R _{ZCD} < 20k | 29μs | 18k |

Current Ripple Reduction (C.R.R) Function

LD7835D features current ripple reduction function to minimum the output capacitor. The C.R.R rate is subject to R_F resistance as shown in Fig. 1. The following table is a suggestion for CRR rate setting.

| R _F (Ω) | CRR Effective Rate | Suggestion (Ω) |
|--------------------------|-----------------------|-------------------|
| 16k < R _F | Heavy | 18k |
| 7k < R _F < 8k | Light | 7.5k |
| R _F < 0.2k | Disable | 0 |

The C.R.R effect is dependent on C.R.R rate, AC line and R_{UP} in fixed output capacitance as shown in the following table for tuning reference.

| C.R.R Rate | AC Line | R _{up} | Current Ripple |
|------------|---------|-----------------|----------------|
| Disable | NA | NA | Original |
| Light | ↓ | ↑ | Lightest |
| Heavy | ↑ | ↓ | Heaviest |

If C.R.R function is enabled, the output capacitance and the saturation knee point of inductor can be minimize. However, power factor and THD will be slightly lower than disabled condition. It's a trade-off factor between power factor and current ripple.

LED Short Protection

If some LED is in short condition, VCC will drop to UVLO (OFF) level and disable the LD7835D. The LD7835D will not resume operation until VCC rises up to next

UVLO (ON) level. If the short condition remains still, the system will enter to hiccup mode.

Over Current Protection (OCP)

The LD7835D detects the MOSFET current from the CS pin, which is for the pulse-by-pulse current limit and output current feedback. The maximum voltage threshold of the CS pin is set at 1.2V. From above, the MOSFET peak current can be obtained from below.

$$I_{PEAK} = \frac{1.2V}{R_S}$$

Over Voltage Protection (VCC OVP)

The maximum rating of the VCC pin is limited below 30V. To prevent VCC from damage due to fault condition, the LD7835D is implemented with OVP function on VCC pin, this value is about 28V. As soon as the VCC voltage is over OVP threshold voltage, the output gate drive circuit will be shutdown simultaneously thus to stop the switching of the power MOSFET until the next UVLO (ON) arrives. The VCC OVP function of the LD7835D is an auto-recovery protection. The Fig. 18 shows its operation. Upon removal of the OVP condition will resume the VCC level and the output operation

drive the power MOSFET directly. The output voltage is clamped at 13V to protect the MOSFET gate even when the VCC voltage rises over 13V.

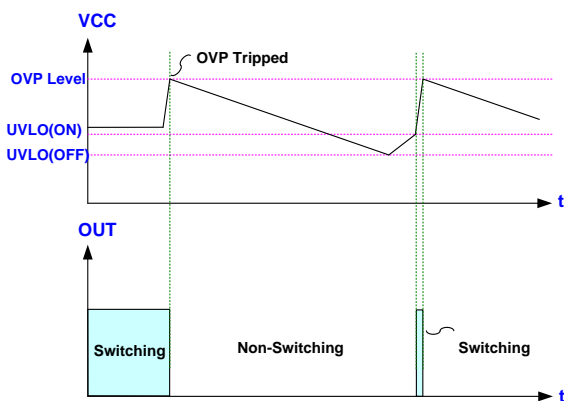

Fig. 18

Output Drive Stage

An output stage of a CMOS buffer, with typical 250mA/-250mA driving capability, is incorporated to

Package Information

SOT-26

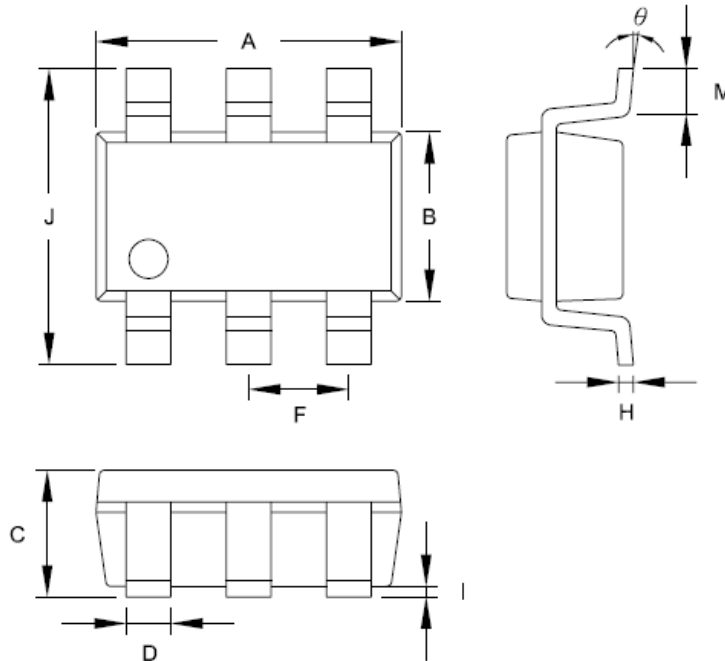

| Symbol | Dimension in Millimeters | | Dimensions in Inches | |
|--------|--------------------------|-------|----------------------|-------|
| | Min | Max | Min | Max |
| A | 2.692 | 3.099 | 0.106 | 0.122 |
| B | 1.397 | 1.803 | 0.055 | 0.071 |
| C | ----- | 1.450 | ----- | 0.057 |
| D | 0.300 | 0.500 | 0.012 | 0.020 |
| F | 0.95 TYP | | 0.037 TYP | |
| H | 0.080 | 0.254 | 0.003 | 0.010 |
| I | 0.050 | 0.150 | 0.002 | 0.006 |
| J | 2.600 | 3.000 | 0.102 | 0.118 |
| M | 0.300 | 0.600 | 0.012 | 0.024 |
| θ | 0° | 10° | 0° | 10° |

Important Notice

Leadtrend Technology Corp. reserves the right to make changes or corrections to its products at any time without notice. Customers should verify the datasheets are current and complete before placing order.

Revision History

| REV. | Date | Change Notice |
|------|------------|------------------------|
| 00 | 05/03/2017 | Original Specification |