

## 4-Channel LED Backlight Driver

REV: 00

### General Description

The LD7889A is a 4-channel linear current controller which combines with a boost switching controller. It's an ideal solution for driving high power LED backlights. The LD7889A can deliver high accuracy of constant current to 4 LED strings with 4 internal MOSFET. For each LED string, the current is adjustable to drive up to 240mA.

The LD7889A incorporates 4 individual current regulator channels to give accurate driving current for each LED string. The string-to-string tolerance is set within  $\pm 2\%$ .

PWM input pin controls LED brightness from PWM control signals.

The other features include LED short and open protection, cycle by cycle current limit, and thermal shutdown.

### Features

- Input Voltage range: 4.5V to 36V
- Drives up to 4 strings in parallel, up to 240mA per string
- Time-shift PWM dimming control
- External PWM dimming control
- LED short circuit protection
- LED open string protection
- MOSFET over-current protection
- Over-temperature protection
- Status output

### Applications

- UMPC and Notebook Computer Backlight
- Backlight for GPS, Portable DVD
- LED Backlight for LCD Monitor/ TV

### Typical Application

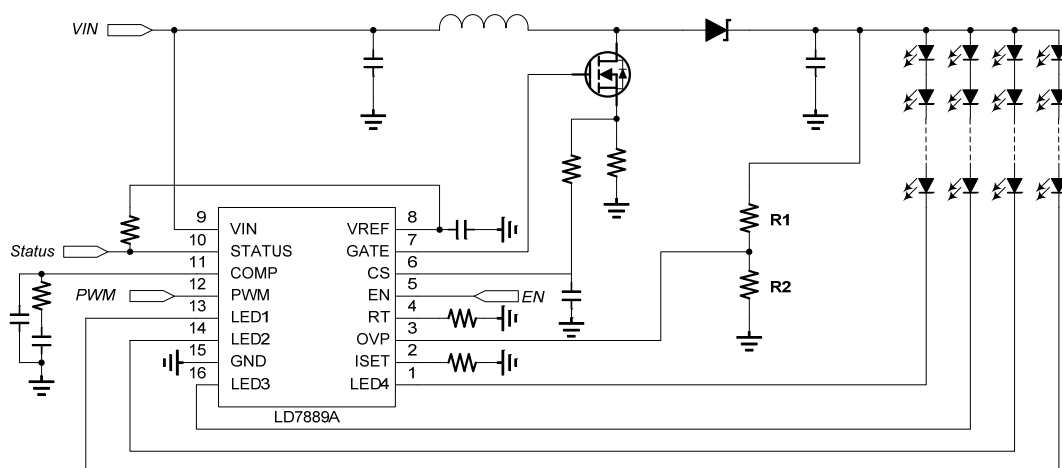
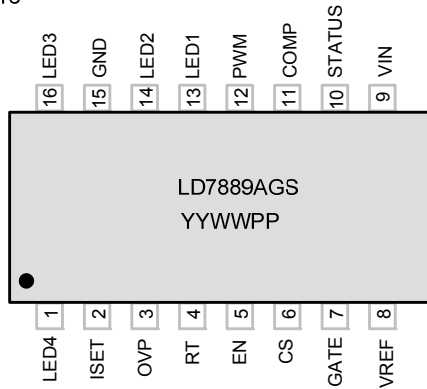

Fig.1 Typical Circuit for 4 Strings of LED Line Bar

## Pin Configuration

SOP-16



YY: Year Code  
 WW: Week Code  
 PP: Production Code

TSSOP-EP-16

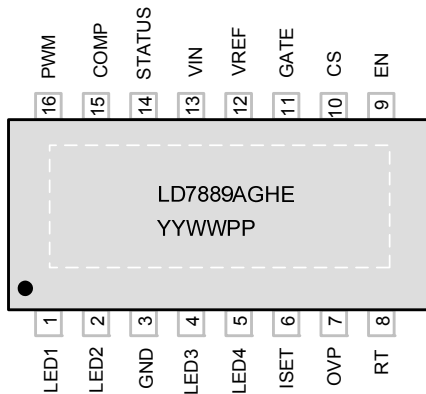

DIP-16

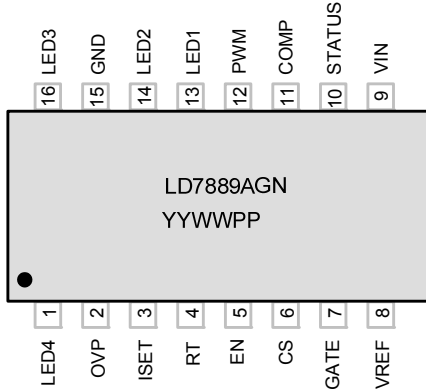

## Ordering Information

Part number	Package	Top Mark	Shipping
LD7889AGS	SOP-16	LD7889AGS	2500 /tape & reel
LD7889AGHE	TSSOP-EP-16	LD7889AGHE	2500 /tape & reel
LD7889AGN	DIP-16	LD7889AGN	1800 /Tube/ Carton

The LD7889A is green packaged.

## Pin Descriptions

PIN SOP-16	PIN TSSOP-16	PIN DIP-16	NAME	FUNCTION
1	5	1	LED4	LED string #4 current input.
2	6	3	ISET	LED current resistor setting
3	7	2	OVP	Over-voltage protection
4	8	4	RT	Operating frequency resistor setting
5	9	5	EN	Chip enable pin.
6	10	6	CS	Power MOSFET current sense pin.
7	11	7	GATE	Low side Power MOSFET Driver
8	12	8	VREF	5V Internal linear regulator output pin with an external ceramic capacitor of 1 $\mu$ F or greater.
9	13	9	VIN	Input Power of the chip. Bypass with at least 1 $\mu$ F ceramic capacitor and place it close to VIN pin.
10	14	10	STATUS	LED operation status output
11	15	11	COMP	Soft start and control loop Compensation.
12	16	12	PWM	PWM dimming input.
13	1	13	LED1	LED string #1 current input.
14	2	14	LED2	LED string #2 current input.
15	3	15	GND	IC ground
16	4	16	LED3	LED string #3 current input.

## Block Diagram

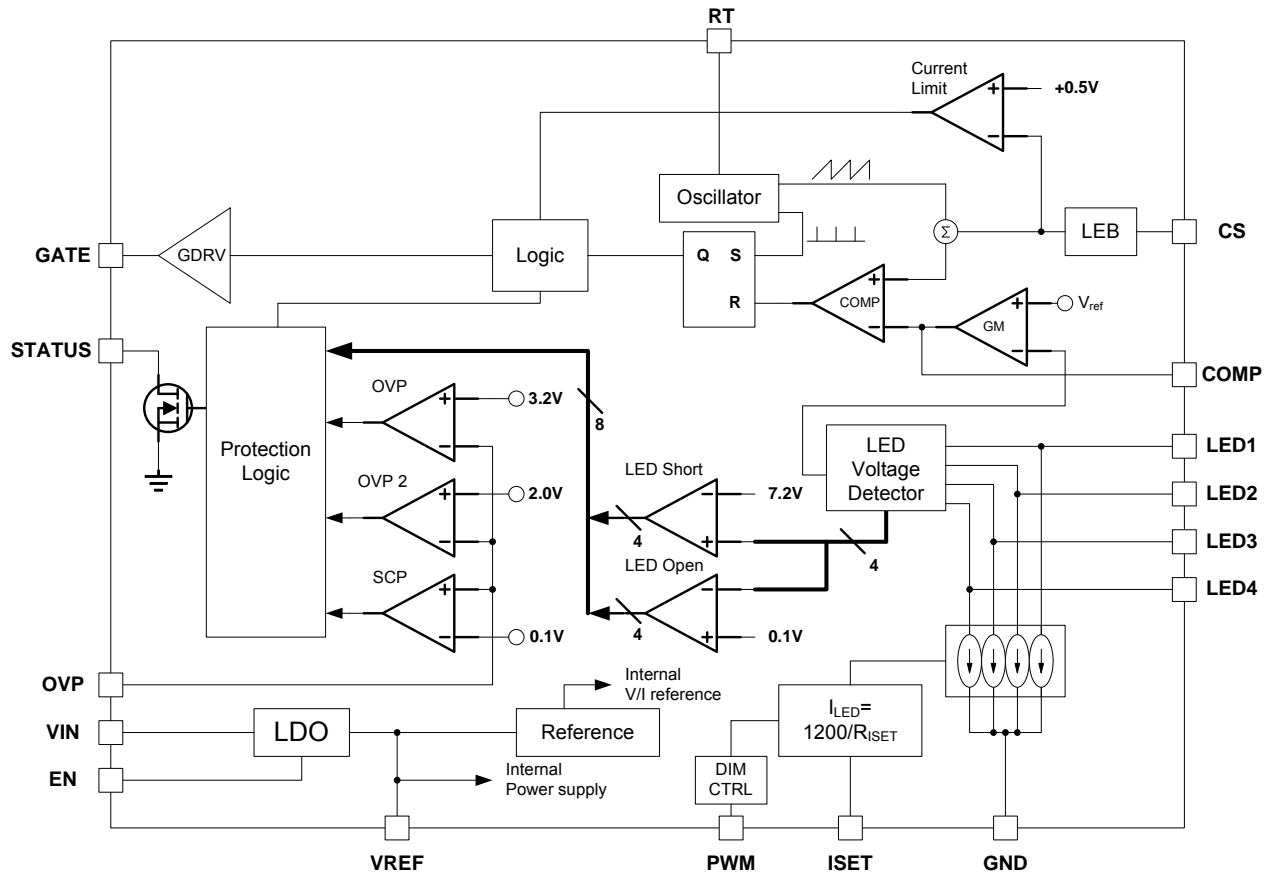

## Absolute Maximum Ratings

VIN .....	40V
CS.....	-0.3V ~ 5.5V
V <sub>LED1</sub> to V <sub>LED4</sub> .....	-0.3V ~ 60V
STATUS, OVP, PWM, EN.....	-0.3V ~ 5.5V
VREF, COMP, RT, GATE, ISET.....	-0.3V ~ 6V
GND .....	±0.3V
I <sub>LEDx</sub> pulse forward current (Pulse time≤2ms).....	400mA
I <sub>LED1</sub> to I <sub>LED4</sub> .....	330mA
Package Thermal Resistance	
TSSOP-EP-16, θ <sub>JA</sub> .....	60 °C/W
SOP-16, θ <sub>JA</sub> .....	110 °C/W
DIP-16, θ <sub>JA</sub> .....	80 °C/W
Operating Temperature Range .....	-40°C to 85°C
Storage Temperature Range.....	-55°C to 125°C
Junction Temperature .....	150°C
Lead Temperature (Soldering, 10sec) .....	260°C
ESD Level (Human Body Model).....	2KV
ESD Level (Machine Model).....	200V

## Recommended Operating Conditions

Input Supply Voltage.....	4.5V to 36V
I <sub>LED1</sub> to I <sub>LED4</sub> .....	20mA to 240mA

### Caution:

Stresses beyond the ratings specified in “Absolute Maximum Ratings” may cause permanent damage to the device. This is a stress only rating and operation of the device at these or any other conditions above those indicated in the operational sections of this specification is not implied.

## Electrical Characteristics

( $V_{IN}=24V$ ,  $T_A=25^{\circ}C$ , unless otherwise noted.)

PARAMETER	CONDITIONS	MIN.	TYP.	MAX.	UNITS
<b>Input Power</b>					
Input Voltage range		4.5		36	V
VIN Operating Current	EN=PWM=5V		10		mA
VIN Shutdown Current	EN=PWM=0V		2	10	$\mu A$
VIN Stand-By Current	EN=5V, PWM=0V		600	800	$\mu A$
<b>Under Voltage Lockout</b>					
Lockout Threshold	$V_{REF\_LOCKOUT}$	3.6	4.1	4.2	V
Resume Threshold	$V_{REF\_RESUME}$	4.2	4.4	4.6	V
<b>Reference Voltage</b>					
Reference Voltage	$V_{REF}$ , $V_{IN}>6V$	5.25	5.5	5.75	V
VREF Output Current Capability	$I_{VREF}$			30	mA
<b>Drive Logic</b>					
GATE Sink Resistance	$V_{IN}>6V$	1	3.5	5	$\Omega$
GATE Source Resistance	$V_{IN}>6V$	1	5	9	$\Omega$
Minimum MOSFET ON Time			150		ns
<b>LED Current Regulation</b>					
Regulation LED Current per Channel	$I_{SET}=12K\Omega$ , $K_{ISET}=1200$ Chip to chip average current	92	100	108	mA
Voltage at ISET pin		1.225	1.25	1.275	V
LEDs Current Matching	LED current=100mA Calculating: $\frac{I_{MAX} - I_{MIN}}{2 \times I_{Average}} \times 100\%$		$\pm 2$		%
LED regulation voltage	$I_{LED}=100mA$ /per channel		300	350	mV
LED regulation voltage	$I_{LED}=240mA$ /per channel		550	650	mV
<b>Boost Controller</b>					
Adjustable Switching frequency		100		1000	kHz
Default Switching frequency	$R_{RT} = 260k\Omega$	180	200	220	kHz
Leading edge blanking time			150		ns
Voltage at RT pin		1.176	1.2	1.224	V
Boost Maximum duty cycle	$F_{sw}=500kHz$	90	93	96	%

PARAMETER	CONDITIONS	MIN.	TYP.	MAX.	UNITS
<b>EN and PWM Dimming</b>					
EN and PWM Logic	Enable	1.8			V
	Disable			0.8	V
EN Pull Down Resistance		1M			$\Omega$
Turn-on time, PWM rising to ILED from shutdown (Tp1)	(Note1)		4000		ns
LED rise time (TR)	(Note1)		600		ns
LED fall time(TF)	(Note1)		600		ns
LED "ON" Period (ton)	(Note1)		1		cycle
LED "OFF" Period (toff)	(Note1)		1		cycle
PWM dimming frequency		100		25k	Hz
<b>Protection</b>					
LED Open String Protection Threshold	OVP	1.9	2.0	2.1	V
Shutdown Under Abnormal condition	OVP	3.0	3.2	3.4	V
LED Short Circuit Protection Threshold	LED1~LED4		7.2		V
Boost- Short circuit startup	During start-up,		0.1		V
Boost- Short circuit startup Hysteresis			50		mV
Thermal Shutdown threshold			140		$^{\circ}\text{C}$
Thermal Shutdown hysteresis			30		$^{\circ}\text{C}$
<b>MOSFET Over-Current Protection</b>					
N-FET Over-Current Protection	CS	0.47	0.5	0.53	V
<b>STATUS Output</b>					
Sink Resistance			20	100	$\Omega$

Note1:

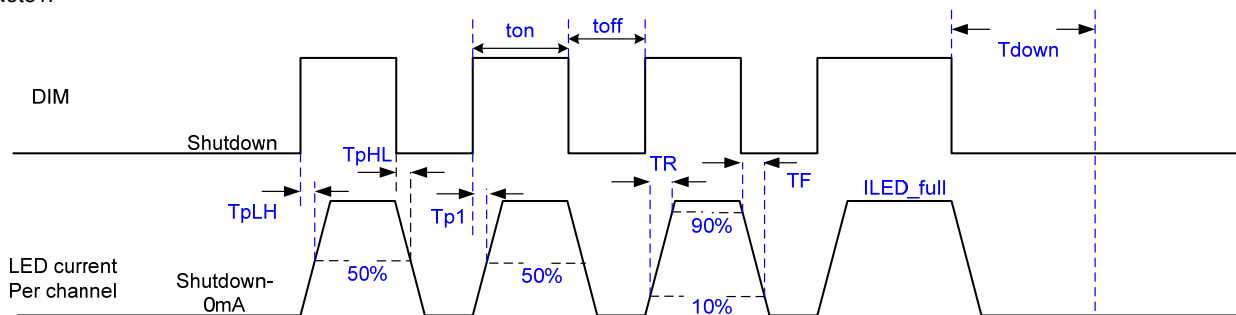

## Typical Performance Characteristics

22 LEDs in series, 4 strings parallel, 120mA/string,  $C_{OUT}=4.7\mu F$ , unless otherwise noted.

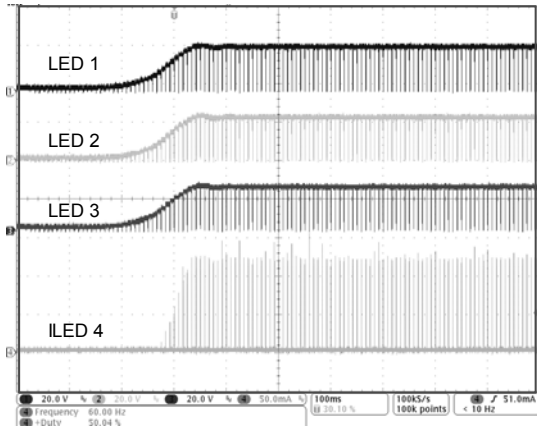

Fig. 2  $V_{IN}=16V$ , " $f_{DIM}=120Hz$ , Duty=5%"

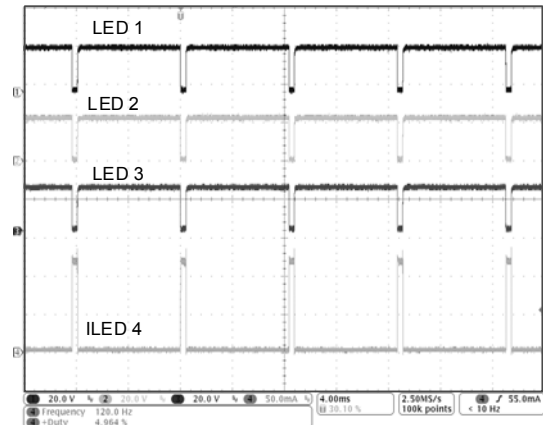

Fig. 3  $V_{IN}=16V$ , " $f_{DIM}=120Hz$ , Duty=5%"

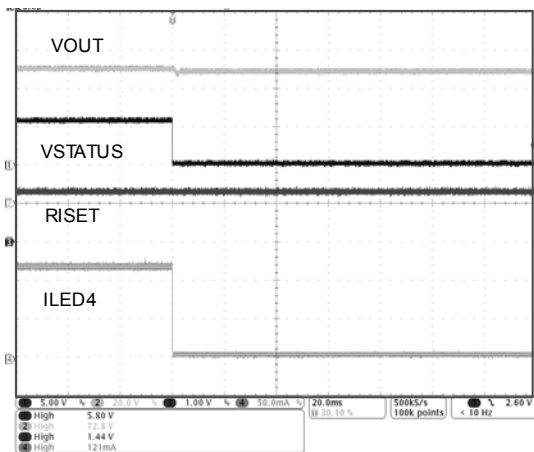

Fig. 4  $V_{IN}=16V$ , "LED Short Protection ,Dim Duty=100%"

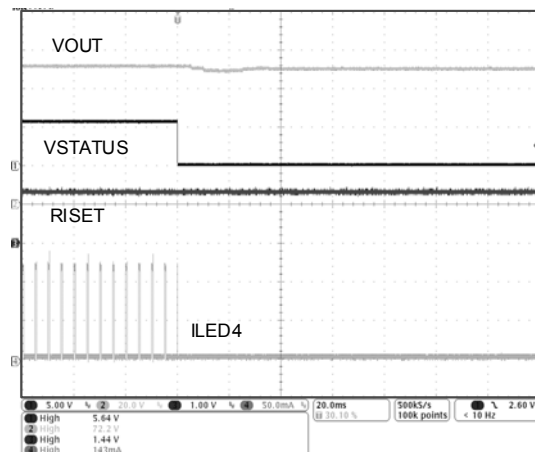

Fig. 5  $V_{IN}=16V$ , "LED Short Protection,  $f_{DIM}=200Hz$ , Duty=10%"

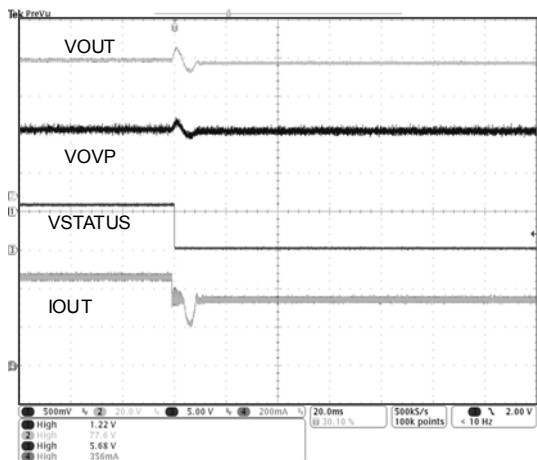

Fig. 6  $V_{IN}=16V$ , "LED Open Protection ,Dim Duty=100%"

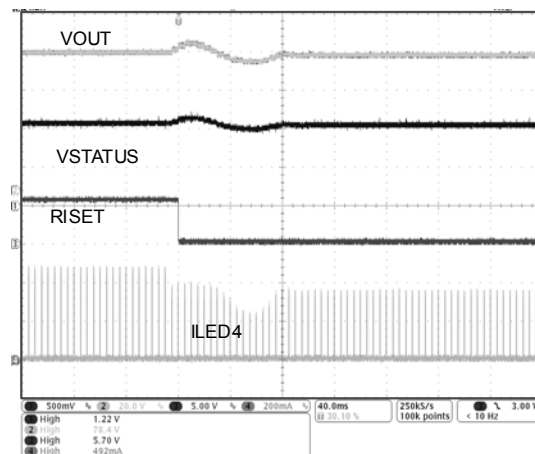

Fig. 7  $V_{IN}=16V$ , "LED Open Protection ,  $f_{DIM}=200Hz$ , Duty=10%"



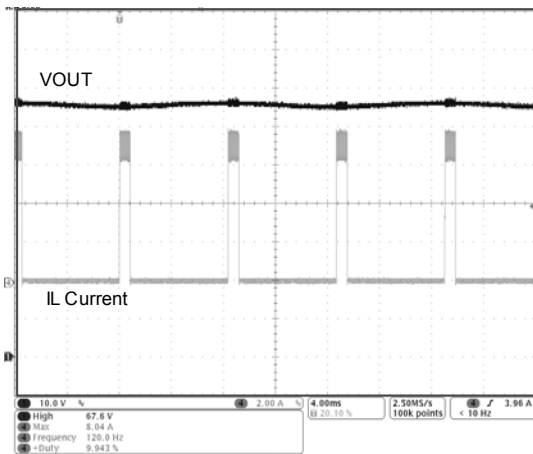

Fig. 8  $V_{IN}=16V$ ,  $V_{LED}=70V$ ,  $320mA/string$ , " $f_{DIM} = 120Hz, Duty=10\%$ "

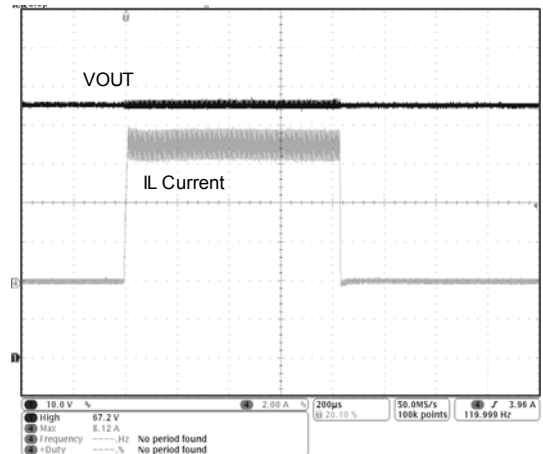

Fig. 9  $V_{IN}=16V$ ,  $V_{LED}=70V$ ,  $320mA/string$ , " $f_{DIM} = 120Hz, Duty=10\%$ "

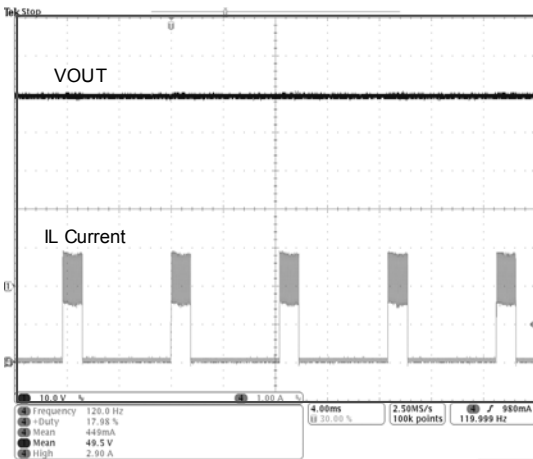

Fig. 10  $V_{IN}=16V$ ,  $V_{LED}=50V$ ,  $160mA/string$ , " $f_{DIM} = 120Hz, Duty=20\%$ "

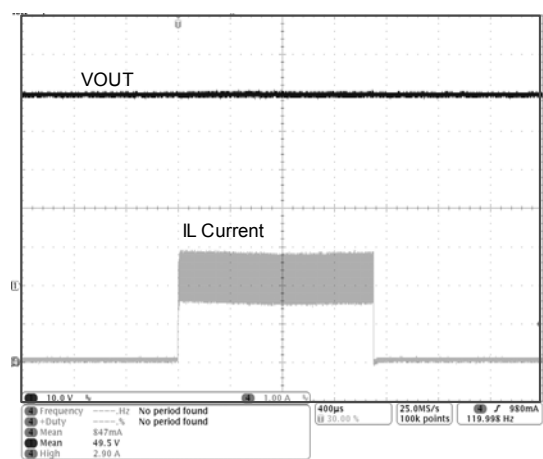

Fig. 11  $V_{IN}=16V, V_{LED}=50V$ ,  $160mA/string$ , " $f_{DIM} = 120Hz, Duty=20\%$ "

## Application Information

### Basic Description

The LD7889A is a high-efficiency driver, ideally for LED backlight application. It incorporates with two major functions, a DC-DC boost controller with peak current-mode control and a 4-channel LED driver with constant current of sink capability from 20mA to 240mA per channel.

LD7889A features adaptive voltage control that adjusts the converter output voltage according to the total forward voltage of LED strings. It detects the drop of LED voltage across the constant current-sink drivers and enhances power dissipation in the device.

The other features include LED short and open protection, cycle by cycle current limit, and thermal shutdown

### Current-Mode DC-DC Controller.

The peak current-mode controller allows boost converter to generate the required output voltage for LED strings. The switching frequency is programmable in the range between 100 kHz and 1 MHz through a resistor connected from RT pin to ground.

Once the device is turned on, the external MOSFET will drive the inductor current to ramp up linearly until the MOSFET reaches the peak current level set by CS pin.

The peak inductor current is sensed by measuring the voltage across the current-sense resistor  $R_{CS}$ , which is connected from the source of external MOSFET to ground. LD7889A features leading edge blanking time to suppress the switching noise from the external MOSFET. A PWM comparator compares the current-sense voltage and the slop compensation signal with the output of the GM error amplifier. The device will turn off the external MOSFET when the voltage over CS exceeds the error amplifier's output voltage. This process repeats in every switching cycle to achieve peak current-mode control.

### Programming the LED Current

The LED current is programmable by placing a resistor between the ISET pin and ground. The ISET pin resistor is recommended to select in the range from  $5k\Omega$  to  $60k\Omega$ . Set the desired LED current according to the following equation:

$$I_{LED} (mA) = \frac{1200}{R_{ISET} (k\Omega)}$$

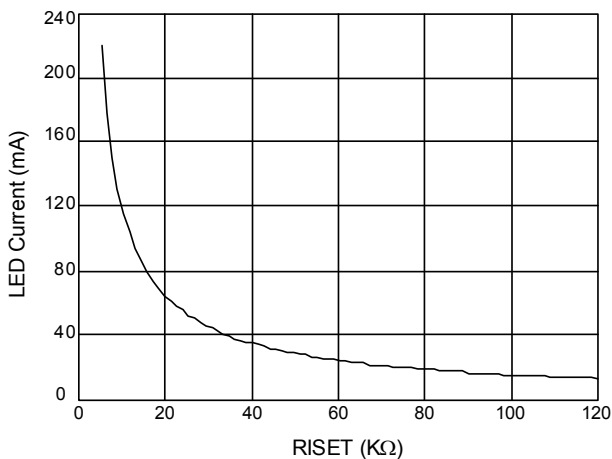

Fig. 11 LED Current vs. R\_ISET

### Switching Frequency Selection

LD7889A can operate in fixed frequency mode. The constant operation frequency is set by an external resistor connected between RT pin and ground. The resistor sets the charging current for internal oscillator.

$$F_{SW} (kHz) = \frac{52000}{RT (k\Omega)}$$

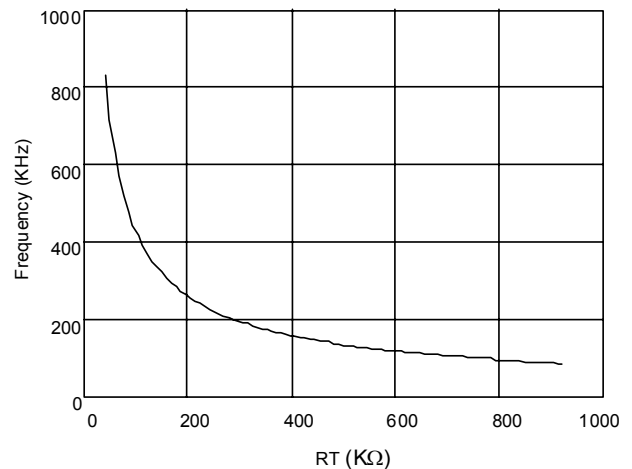

Fig. 12 Frequency vs. RT

### PWM dimming

PWM dimming control is achieved by applying an external PWM signal of 100Hz to 25kHz to the PWM pin.

### Power Sequence and Timing Chart

That is, the supply voltage must be applied to VIN pin before the dimming signal (to DIM pin) by at least 1ms and then the shutdown signal (to EN pin). Please follow the proper power sequence in below timing chart.

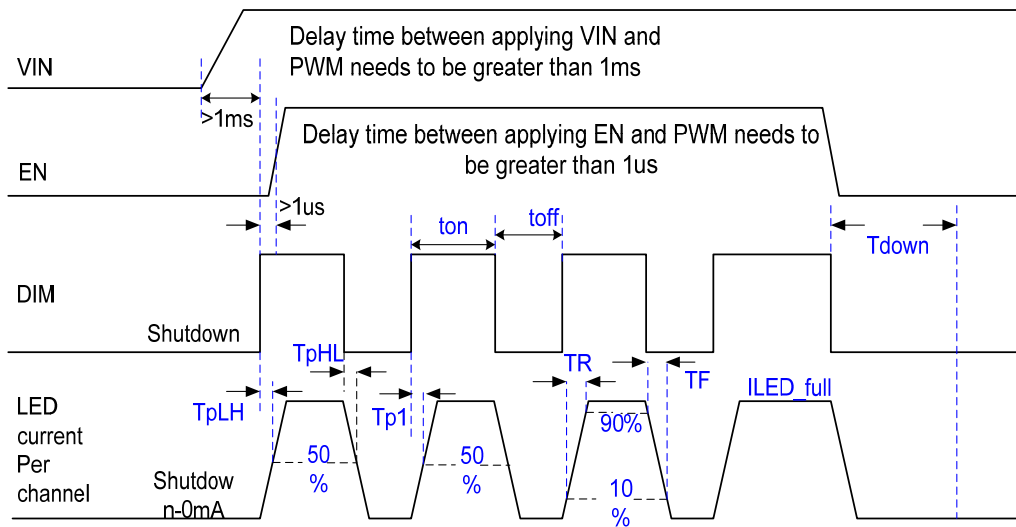

## MOSFET Over-Current Protection

The LD7889A provides cycle-by-cycle current limit to protect the MOSFET. During the MOSFET turning on, LD7889A detects the CS pin voltage and if  $V_{CS}$  rises above approximately 0.5V, the GATE will shut off.

For suppress switch transients could add the RC filter to close the LD7889A CS pin. The typical suggestion value is  $R=1k\Omega$ ,  $C=100pF$ .

## Loop compensation

The LD7889A has an internal trans conductance error amplifier for LED current regulation for COMP output to compensate the control loop. In case of open LED event that all LED strings are open, the COMP node will compensate the control loop still. The external inductor, output capacitor, the compensation resistor and the capacitor determine the loop stability. The inductor and output capacitor are chosen based on the performance, size and cost. The compensation resistor and capacitor at COMP are selected to optimize control loop stability. For typical LED applications, a  $0.22\mu F$  compensation capacitor in series with  $3k\Omega$  resistor at COMP is adequate.

## LED Short Circuit Protection

The voltage of LED1 ~ LED4 pins exceeds a typical threshold of approximately 7.2V during normal operation, the corresponding string be turned off and latched.

## LED Open String Protection

When LED1-4 pins voltage falls below about 0.1V and  $V_{OT}$  will boost up until the voltage at pin OVP reaches a typical threshold of approximately 2.0V threshold. That will set the LED output over voltage ( $V_{LED\_OVP2}$ ) as following equation:

$$V_{LED\_OVP2}(V) = 2.0 \times \frac{R_1 + R_2}{R_2}$$

## Thermal protection

Thermal protection limits total power dissipation in this device. When the junction temperature reaches  $140^\circ C$  approximately, the thermal sensor signals the shutdown logic turning off this device. The thermal sensor will turn this device on again after the IC's junction temperature cools by  $30^\circ C$ .

## PCB Layout Guideline

It's recommended to separate the high frequency switching current from the low-level control signals in

layout. The high switching current (MOSFET, inductor, gate driver and LED return ends) may disturb the other low-level signals in the feedback loop and protection circuitry. As a result, it may cause the control function to behave abnormally. To avoid these issues, a few guidelines are recommended for the PCB layout, as below.

1. VREF bypass capacitor connected with signal ground must be placed as close as possible to the IC. The traces between capacitor and VREF pin should be kept as short as possible to avoid noise interference.
2. VIN bypass capacitor connected with signal ground must be placed as close as possible to the IC. The traces between capacitor and VIN pin should be kept as short as possible to avoid noise interference.
3. Use broader traces for VIN, VOUT and power ground. Components such as the power MOSFET and decoupling capacitors connected to VIN, VOUT and power ground, have high input/output current. To minimize power loss in these traces, the resistance of traces should be kept as low as possible.
4. Use broader traces between power MOSFET drain, inductor and diode. There is high current in these traces. To minimize power loss in these traces, the resistance of traces should be kept as low as possible.
5. Keep the gate drive traces short and board between the IC driver output, GATE pin, and the power MOSFET. The driving traces have a high current spike during inverter operation. To minimize power MOSFET switching loss or oscillation voltage in the gate driver signal, the drive traces should be as board and short as possible to minimize resistance and parasitic inductance.

## Package Information

SOP-16

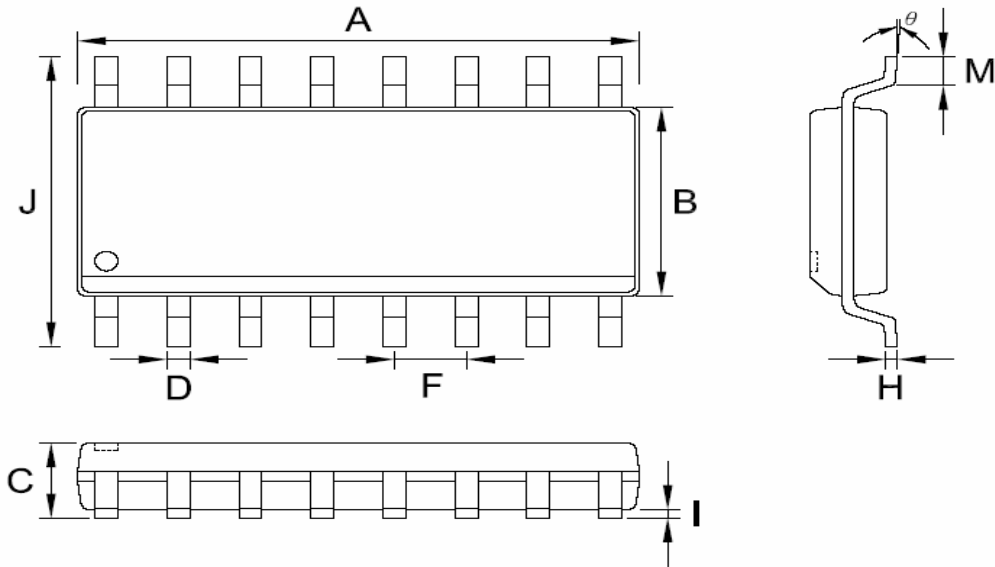

Symbol	Dimension in Millimeter		Dimension in Inch	
	Min	Max	Min	Max
A	9.800	10.010	0.386	0.394
B	3.800	4.000	0.150	0.157
C	1.346	1.753	0.053	0.069
D	0.330	0.510	0.013	0.020
F	1.27 TYP.		0.05 TYP.	
H	0.178	0.254	0.007	0.010
I	0.100	0.254	0.004	0.010
J	5.790	6.200	0.228	0.244
M	0.380	1.270	0.015	0.050
$\theta$	0°	8°	0°	8°

## TSSOP-EP-16

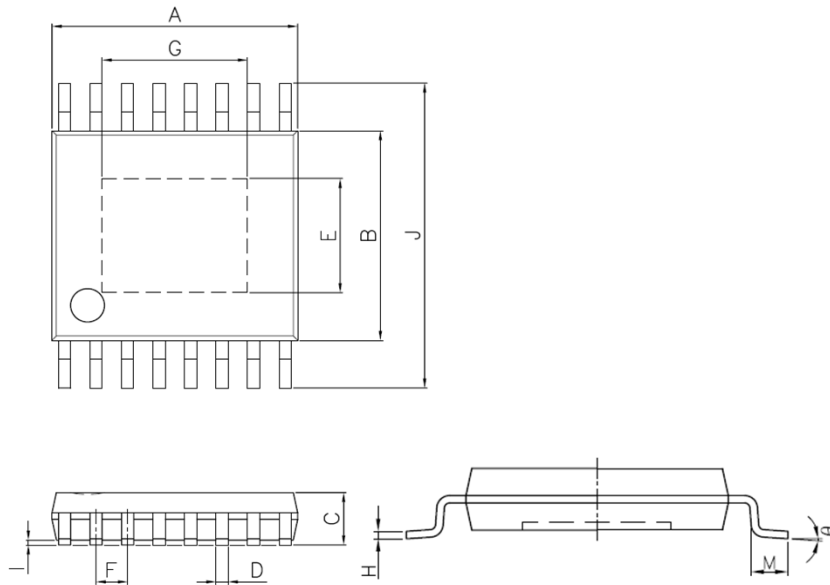

Symbol	Dimension in Millimeter		Dimension in Inch	
	Min	Max	Min	Max
A	4.900	5.100	0.193	0.201
B	4.300	4.500	0.169	0.177
C	0.850	1.200	0.033	0.047
D	0.190	0.300	0.007	0.012
E	2.000	3.000	0.079	0.118
F	0.65 TYP.		0.026 TYP.	
G	2.000	3.000	0.079	0.118
H	0.127 TYP.		0.005 TYP.	
I	0.005	0.150	0.000	0.006
J	6.200	6.600	0.244	0.260
M	0.450	0.750	0.018	0.030
θ	0°	8°	0°	8°

## DIP-16 (300mil)

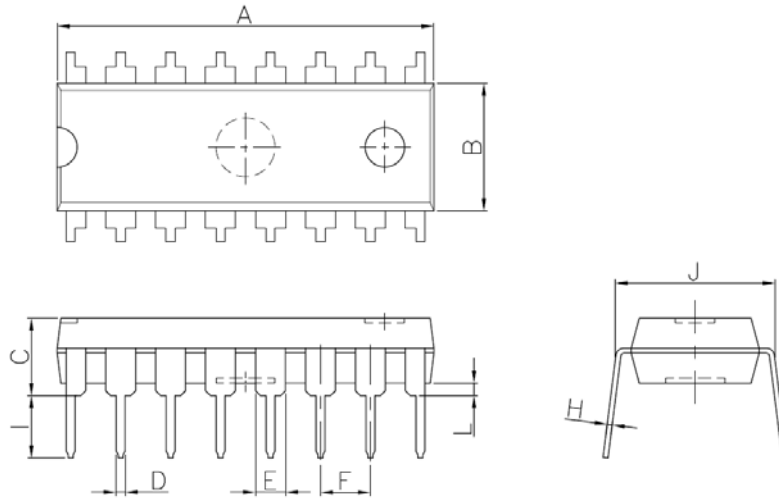

Symbol	Dimension in Millimeter		Dimension in Inch	
	Min	Max	Min	Max
A	18.880	19.320	0.743	0.761
B	6.096	7.112	0.240	0.280
C	---	5.334	---	0.210
D	0.356	0.584	0.014	0.023
E	1.140	1.780	0.045	0.070
F	2.337	2.743	0.092	0.108
I	2.921	3.556	0.115	0.140
J	7.366	8.260	0.290	0.325
L	0.380	---	0.015	0.000

### Important Notice

Leadtrend Technology Corp. reserves the right to make changes or corrections to its products at any time without notice. Customers should verify the datasheets are current and complete before placing order.

## IR Profile for SMD Devices

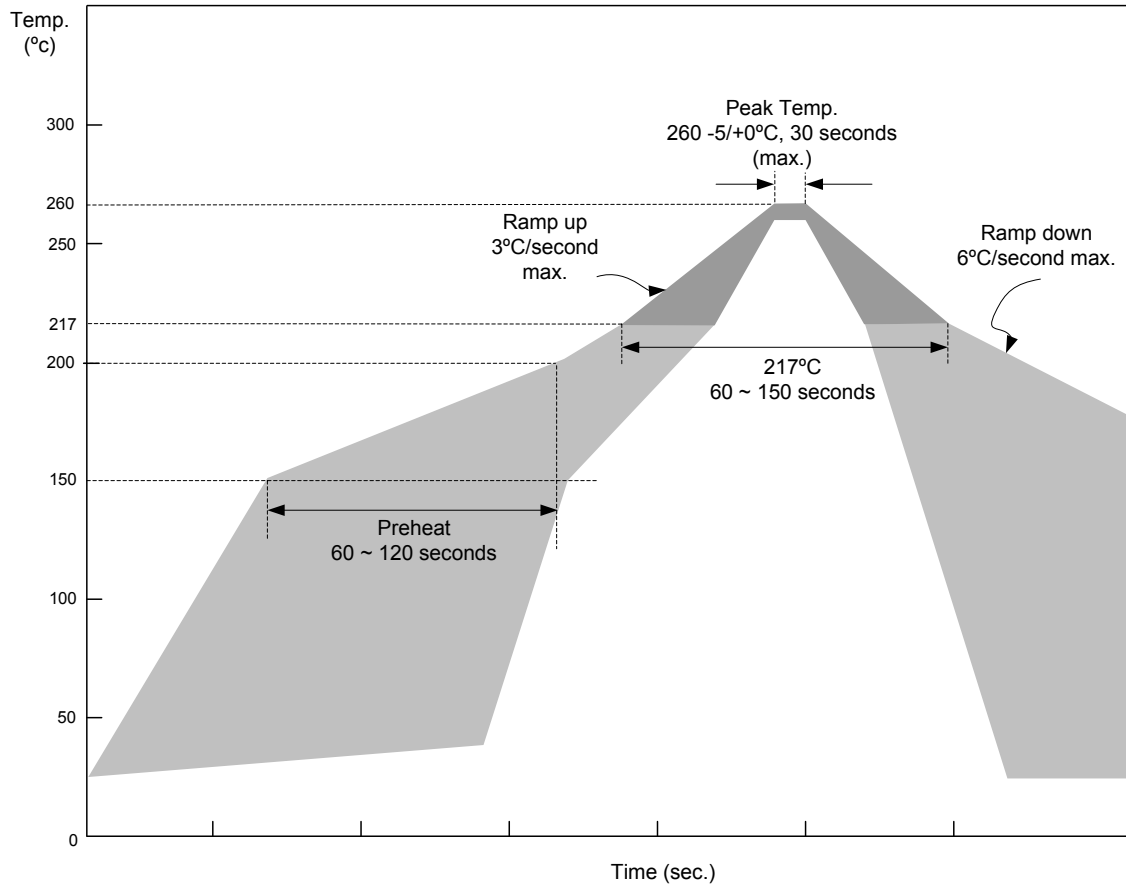

Item	Average Ramp-up Rate	Pre-heat (150 ~ 200°C)	Time Maintained Above 217°C	Peak Temp.	Ramp-down Rate
Required	3°C(max) /sec	60~120 sec	60~150 seconds	260 +0/-5°C 30 seconds	6°C (max) /sec



**Revision History**

Rev.	Date	Change Notice
00	3/29/2012	Original Specification