

Secondary-side Dimmable Constant Current and Voltage Controller

REV: 00

General Description

The LD8115A is an isolation secondary LED constant current and constant voltage controller, and provide the secondary-side direct dimming interface by DC level and PWM duty single for smart LED lighting application.

The device features include wide input voltage range from 3.6V to 38V, high-accuracy LED operation current and output constant voltage.

The LD8115A is the SOP-8 package to minimize the PCB size as well as component counts.

Features

- Secondary-Side Constant Current and Voltage Feedback
- High Accuracy 200mV (+/-2%) of LED Current Threshold Control
- Precision 1.25V Reference Voltage (+/-1%)
- Low operation current (< 0.5mA)
- Wide VCC Operation Range 3.6~38V
- Precision Secondary-side LED current Dimming with Analog and PWM
 - Analog Dimming : 0.1V~2.5V
 - PWM: 500Hz~30kHz

Applications

- LED Lighting Driver Application
- Charger

Typical Application

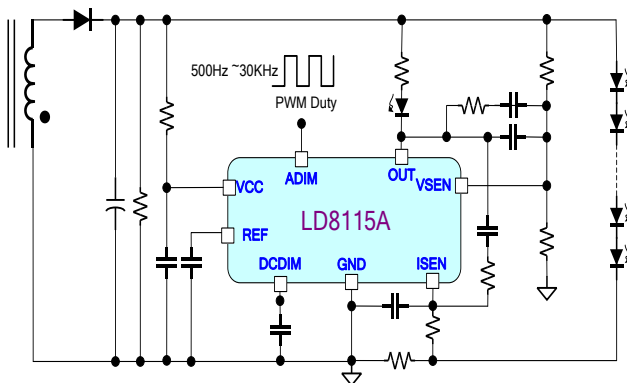

Fig. 1 Application circuit-PWM Dimming

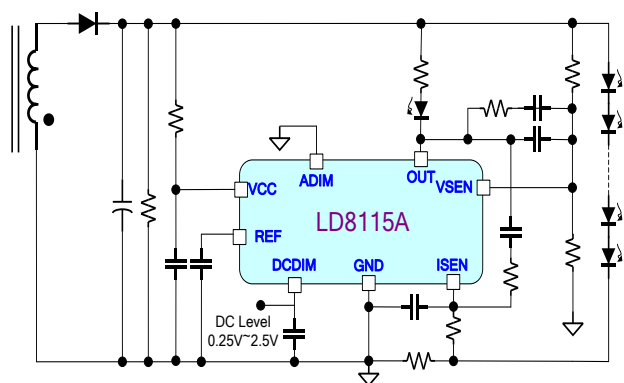
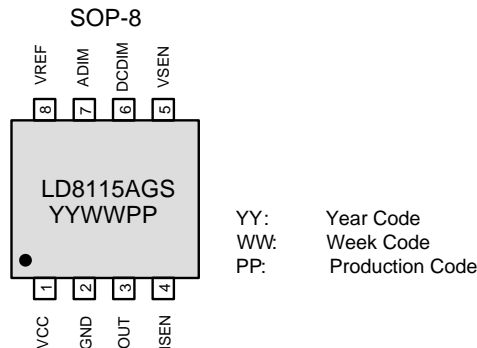

Fig. 2 Application circuit- Analog Dimming

Pin Configuration



Ordering Information

Part number	Package	Top Mark	Shipping
LD8115A GS	SOP-8 Green package	LD8115AGS	2500 /tape & reel

The LD8115A is ROHS compliant/Green Packaged.

Protection Mode

Int. OTP	VCC OVP	Constant Current Loop	Constant Voltage Loop
Auto recovery	None	Auto recovery	Auto recovery

Pin Descriptions

Pin	NAME	FUNCTION
1	VCC	Power Supply to IC, a small bypass capacitor (0.1 μ F) to GND and closed IC as possible.
2	GND	Ground. This pin should be tied as close to the ground output terminal of the converter as possible to minimize load current effect on the voltage regulation set point
3	OUT	Open-Collector Output .this pin is connected opto-coupler with the limit resistor to error signal to the primary side.
4	ISEN	Current sense pin. The inverting input of the current loop op amp. This pin is tied to the end of the current sense resistor through a decoupling resistor and the threshold voltage at maximum current is 200mV.
5	VSEN	Voltage sense pin. Inverting input of the internal OP-amp. It connected to the mid-point of a resistor divider that senses the output voltage.
6	DCDIM	In Analog dimming control, this pin is DC level signal input for brightness. If the devise is PWM Dimming control, this pin adds a 0.1~1 μ F MLCC capacitor to filtering PWM signal.
7	ADIM	Signal input for brightness control at PWM Dimming. When devise is in analog dimming mode, this pin connects to GND.
8	VREF	Internal linear regulator output pin with an external ceramic capacitor of 1~2.2 μ F.

Block Diagram

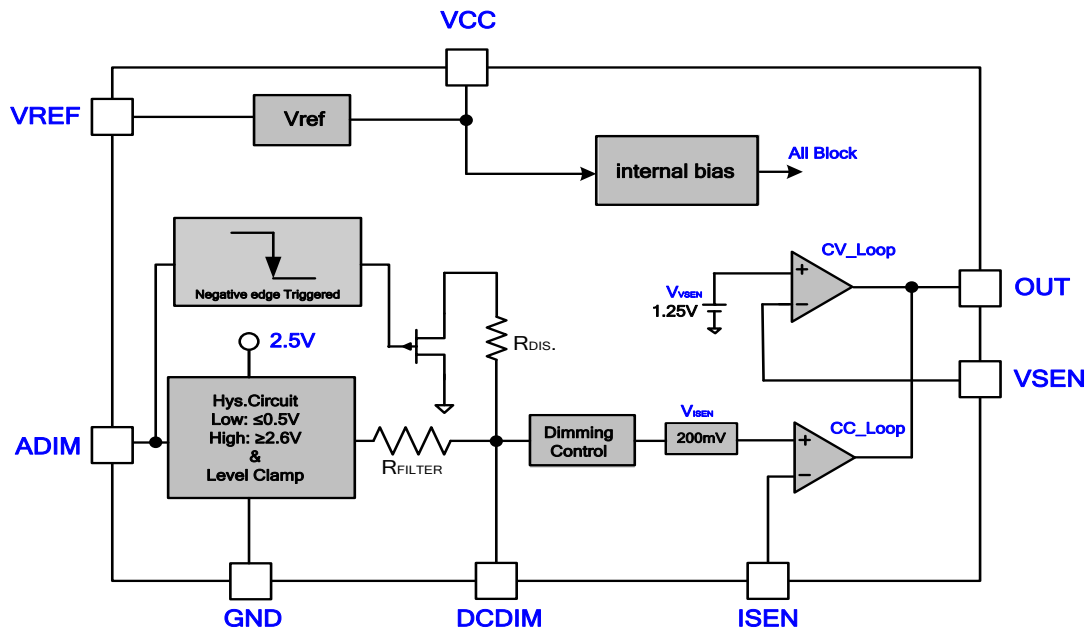

Absolute Maximum Ratings

VCC.....	-0.3V ~ 40V
OUT.....	-0.3V ~ 60V
ADIM, DCDIM.....	-0.3V ~ 16V
VSEN, VREF, ISEN.....	-0.3V ~ 6V
OUT Maximum Sink Current.....	30mA
Maximum Junction Temperature.....	150°C
Storage Temperature Range.....	-65°C to 150°C
Package Thermal Resistance (SOP-8, θ_{JA}).....	160°C/W
Power Dissipation (SOP-8, at Ambient Temperature = 85°C).....	250mW
Lead temperature (Soldering, 10sec).....	260°C
ESD Voltage Protection, Human Body Model.....	2KV
ESD Voltage Protection, Machine Model.....	200V

Caution:

Stress exceeding Maximum Ratings may damage the device. Maximum Ratings are stress ratings only. Functional operation above the Recommended Operating Conditions is not implied. Extended exposure to stress above Recommended Operating Conditions may affect device reliability.

Recommended Operating Conditions

Item	Min.	Max.	Unit
Operating Junction Temperature	-40	125	°C
Supply VCC Voltage	3.6	38	V
Maximum LED Voltage		58	V
VCC pin capacitor	0.1	4.7	μF
VREF pin capacitor	1	2.2	μF
DCDIM pin capacitor @ Use PWM input to ADIM pin	0.1	1	μF
ADIM Acceptable Frequency Range	500	30K	Hz

Note:

1. It's essential to connect VCC pin with a SMD ceramic capacitor (0.1μF~4.7μF) to filter out the undesired switching noise for stable operation. This capacitor should be placed close to IC pin as possible
2. The small signal components should be placed close to IC pin as possible.

Electrical Characteristics

($V_{CC}=15V$, $T_A = 25^{\circ}C$ unless otherwise specified.)

PARAMETER	CONDITIONS	Symbol	MIN	TYP	MAX	UNITS
Supply Voltage (VCC Pin)						
UVLO(OFF)		V_{CC_OFF}	2.5	2.7	2.9	V
UVLO(ON)		V_{CC_ON}	2.8	3.0	3.2	V
Operation Current	$V_{ISEN} = V_{OVP} = 5V$, $V_{DCDIM} = 0V$, OUT Pull Low	I_{VCC}		350	500	μA
Gate Drive Output (OUT Pin)						
Output Low Level	@2mA sink current	V_{OUTL}		200	400	mV
Internal Reference Voltage(VREF Pin)						
Reference Voltage	Good TC $I_{REF} \leq 3mA$	V_{REF}	3.04	3.2	3.36	V
VREF Maximum Output Current ⁽¹⁾		I_{REF}			10	mA
DC Dimming (DCDIM Pin)						
Maximum LED current threshold at DIM pin ⁽¹⁾	$V_{OVP} = 0V$, $V_{ISEN} = 200mV \pm 4mV$	V_{DIM_MAX}	2.6			V
Internal Filter Resistance ⁽¹⁾		R_{FILTER}		1000		$K\Omega$
Internal Discharge Resistance ⁽¹⁾	When V_{ADIM} is Changed from 3V to 0V and de-bounce T_{ADM_OFF}	R_{FILTER}		5		$K\Omega$
PWM Dimming (ADIM Pin)						
Dimming mode Selector		T_{ADIM_OFF}	20		60	ms
ADIM H/L Threshold Voltage		$ADIM_H$	2.6			V
		$ADIM_L$			0.5	V
ADIM Input Resistor		R_{ADIM}	300		600	$K\Omega$
DCDIM Discharge Resistor	When ADIM signal from high to low and $T_{ADIM_OFF} > 60ms$	R_{DCDIS}		5		$K\Omega$
Current Control Loop (ISEN PIN)						
Maximum LED Current Sense Threshold Voltage	$V_{OVP} = 0V$, $DCDIM = 3.2V$	V_{ISEN}	196	200	204	mV
Minimum LED Current Sense Reference Voltage	$V_{OVP} = 0V$, When $V_{DCDIM} = 0V$ Or $V_{ADIM} = 0V$	V_{ISEN_0}		2	4	mV
Current Loop Input Bias Current ⁽¹⁾		I_{CC_BIAS}			20	nA

($V_{CC}=15V$, $T_A = 25^{\circ}C$ unless otherwise specified.)

PARAMETER	CONDITIONS	Symbol	MIN	TYP	MAX	UNITS
Voltage Control Loop (VSEN PIN)						
Voltage Control Loop Threshold voltage	$V_{ISEN} = 0V$	V_{VSEN}	1.237	1.250	1.263	V
Voltage Loop Input Bias Current ⁽¹⁾		I_{CV_BIAS}	--	--	20	nA
Internal OTP						
OTP Trip Level ⁽¹⁾				135		$^{\circ}C$
OTP Hysteresis ⁽¹⁾			--	30	--	$^{\circ}C$

Note: ⁽¹⁾ Guarantee by Design

Typical Performance Characteristics

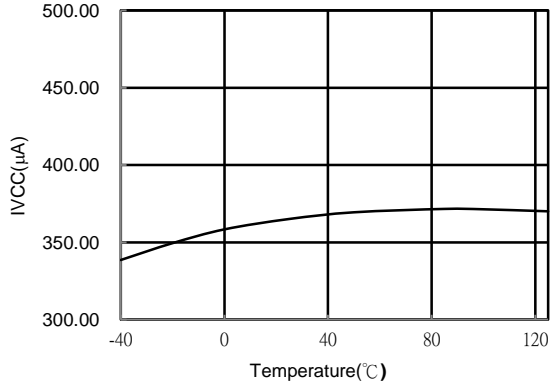

Fig. 3 I_{VCC} vs. Temperature

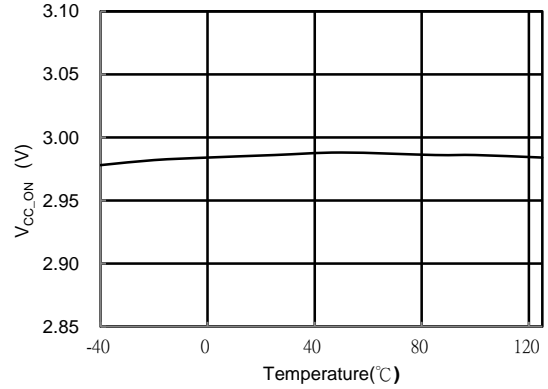

Fig. 4 V_{CC_ON} vs. Temperature

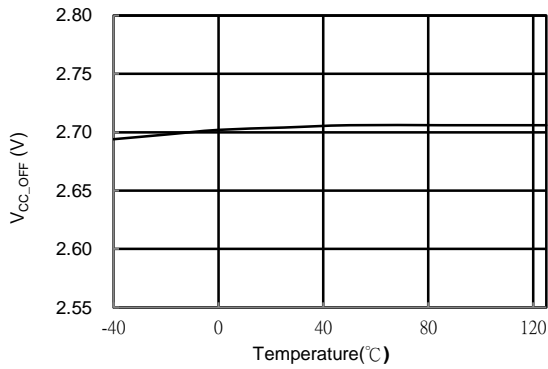

Fig. 5 V_{CC_OFF} vs. Temperature

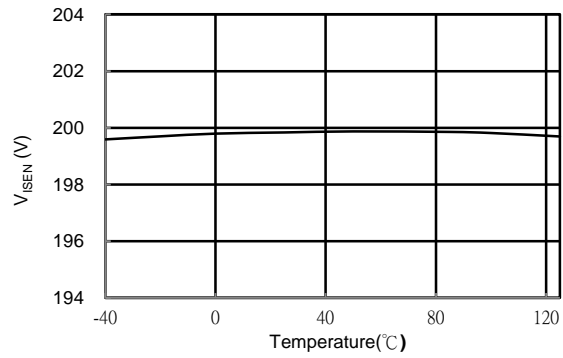

Fig. 6 V_{ISEN} vs. Temperature

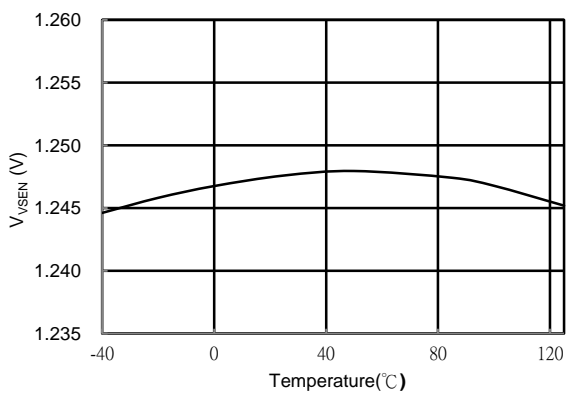

Fig. 7 V_{ISEN} vs. Temperature

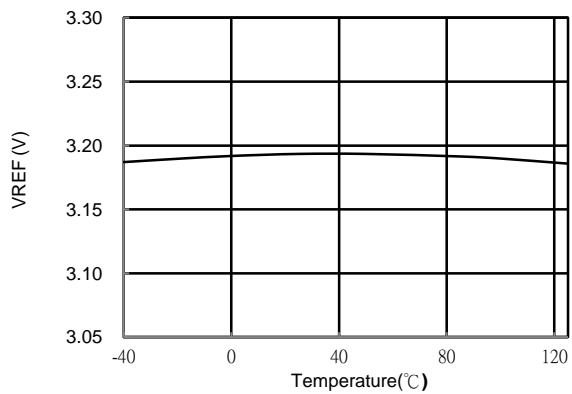

Fig. 8 V_{REF} vs. Temperature

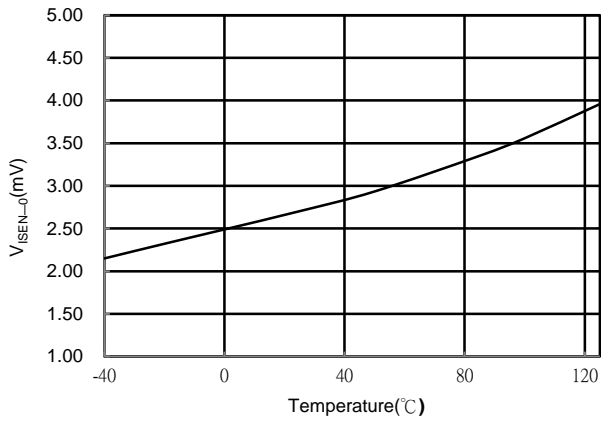

Fig. 9 V_{ISEN_0} vs. Temperature

Application Information

Basic Description

The LD8115A builds two Op-Amps including high-accuracy reference voltage and dimmable function. The CV (Constant voltage) loop Op-Amp is designed for voltage control with it is non-inverting input internally connects to the output of the shunt regulator. The CC (constant current) loop Op-Amp is current control with a low-side sense resistor. The sense resistor determines the current regulation value. And the external R-C components can compensate the two control loops.

Maximum Output Voltage Setting

The main of the voltage control loop are an Op-amp and high-accuracy reference voltage. The VSEN pin is inverting input of the internal Op-amp. It connected to the mid-point of a resistor divider that senses the output voltage. The internal precision reference is 1.25V. The OUT pin is connected Photo-coupler with limit resistor to error signal to primary side for output voltage regulation. The maximum output voltage is determined by following relationship:

$$V_{OUT_MAX} = V_{VSEN}(1 + R_A/R_B)$$

where R_A and R_B are top and bottom feedback resistor values.

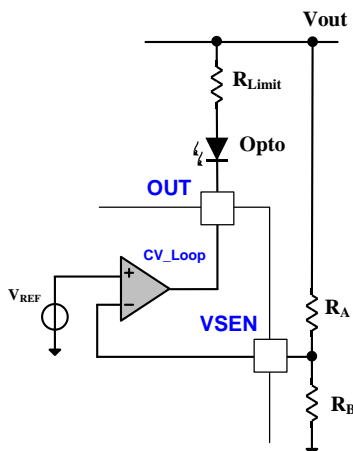

Fig. 10

Constant Current Control Loop

The constant current loop includes an Op-amp and the current sensing resistor. The ISEN pin is inverting input of the current loop op amp. This pin is tied to the end of the current sense resistor through a decoupling resistor and the threshold voltage is 200mV. The maximum current can be obtained from below.

$$I_{OUT_MAX} = \frac{200mV}{R_{SEN}}$$

Dimming Control

The device provides two dimming control is achieved by applying an external PWM signal or direct analog voltage to the DIM pin for brightness control. When DCDIM pin input voltage larger than 2.5V the LED have maximum brightness current. The DCDIM pin is connected a filter capacitance for PWM signal transform to dc voltage for adjustment LED Current Linearity. Minimum adjustment voltage of V_{ISEN} is approach to 1% around.

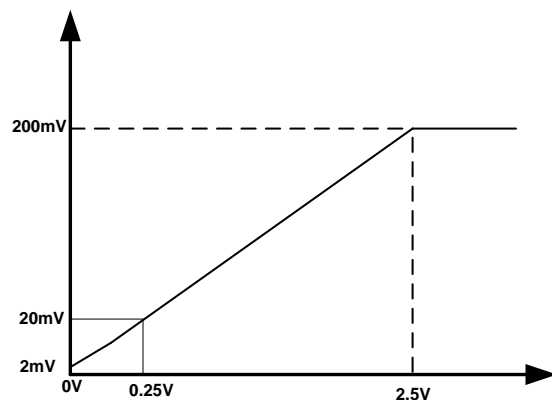

Fig. 11

Thermal protection

When the junction temperature reaches 130°C approximately, the thermal sensor signals would pull the OUT to Low. The Photo-coupler would limit the output voltage and reduce LED current. The thermal sensor will

turn on CC/CV loop again after the IC's junction temperature cools by 30°C.

PCB Design Guideline

1. The bypass capacitor of V_{CC} should be placed as close as possible to the VCC and GND pin of IC.
2. Current Sense current loop should be as short as possible between the ISEN and LD8115A GND pin.
3. The traces of LED current loop should be as strong and short as possible.
4. GND should be connected to a strong ground plane.

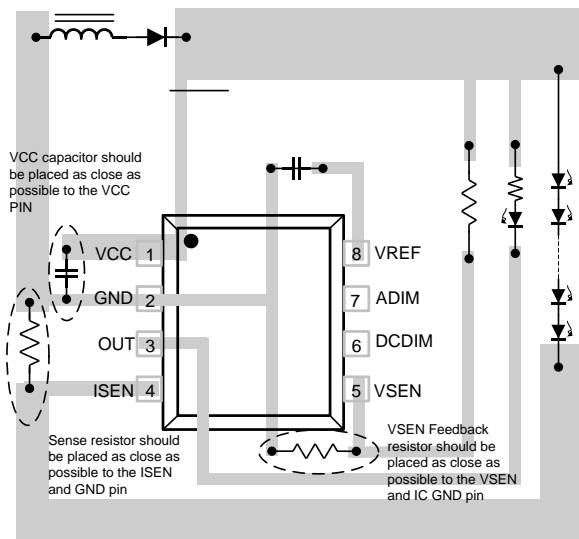
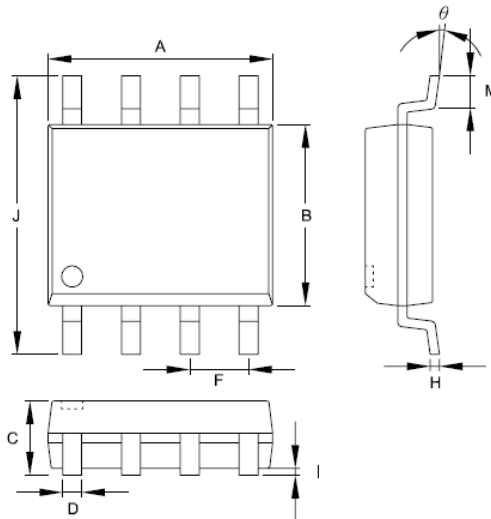

Fig. 12

Package Information

SOP-8



Symbols	Dimensions in Millimeters		Dimensions in Inch	
	MIN	MAX	MIN	MAX
A	4.801	5.004	0.189	0.197
B	3.810	3.988	0.150	0.157
C	1.346	1.753	0.053	0.069
D	0.330	0.508	0.013	0.020
F	1.194	1.346	0.047	0.053
H	0.178	0.254	0.007	0.010
I	0.102	0.254	0.004	0.010
J	5.791	6.198	0.228	0.244
M	0.406	1.270	0.016	0.050
θ	0°	8°	0°	8°

Important Notice

Leadtrend Technology Corp. reserves the right to make changes or corrections to its products at any time without notice. Customers should verify the datasheets are current and complete before placing order.

Revision History

REV.	Date	Change Notice
00	08/02/2017	Original Specification