



LD840EQD

Product Specification

# SPECIFICATION FOR APPROVAL

- ( ● ) Preliminary Specification
- (   ) Final Specification

|       |                      |
|-------|----------------------|
| Title | 84.0" QWUXGA TFT LCD |
|-------|----------------------|

|       |         |
|-------|---------|
| BUYER | General |
| MODEL |         |

|          |                      |
|----------|----------------------|
| SUPPLIER | LG Display Co., Ltd. |
| *MODEL   | LD840EQD             |
| SUFFIX   | SEM1 (RoHS Verified) |

\*When you obtain standard approval, please use the above model name without suffix

| APPROVED BY | SIGNATURE DATE |
|-------------|----------------|
| /           |                |
| /           |                |
| /           |                |

| APPROVED BY              | SIGNATURE DATE |
|--------------------------|----------------|
| S.K.Park / Team Leader   |                |
| <b>REVIEWED BY</b>       |                |
| S.W. Yu / Project Leader |                |
| <b>PREPARED BY</b>       |                |
| K.H.Im / Engineer        |                |

Please return 1 copy for your confirmation with your signature and comments.

**TV Product Development Dept.  
LG Display Co., Ltd.**

LD840EQD

## Product Specification

**CONTENTS**

| Number | ITEM                                     | Page |
|--------|--|------|
|        | COVER                                    | -    |
|        | CONTENTS                                 | 1    |
|        | RECORD OF REVISIONS                      | 2    |
| 1      | GENERAL DESCRIPTION                      | 3    |
| 2      | ABSOLUTE MAXIMUM RATINGS                 | 4    |
| 3      | ELECTRICAL SPECIFICATIONS                | 5    |
| 3-1    | ELECTRICAL CHARACTERISTICS               | 5    |
| 3-2    | INTERFACE CONNECTIONS                    | 7    |
| 3-3    | SIGNAL TIMING SPECIFICATIONS             | 11   |
| 3-4    | V by One SIGNAL SPECIFICATIONS           | 12   |
| 3-5    | COLOR DATA REFERENCE                     | 14   |
| 3-6    | POWER SEQUENCE                           | 15   |
| 4      | OPTICAL SPECIFICATIONS                   | 17   |
| 5      | MECHANICAL CHARACTERISTICS               | 21   |
| 6      | RELIABILITY                              | 24   |
| 7      | INTERNATIONAL STANDARDS                  | 25   |
| 7-1    | SAFETY                                   | 25   |
| 7-2    | EMC                                      | 25   |
| 7-3    | ENVIRONMENT                              | 25   |
| 8      | PACKING                                  | 26   |
| 8-1    | INFORMATION OF LCM LABEL                 | 26   |
| 8-2    | PACKING FORM                             | 26   |
| 9      | PRECAUTIONS                              | 27   |
| 9-1    | MOUNTING PRECAUTIONS                     | 27   |
| 9-2    | OPERATING PRECAUTIONS                    | 27   |
| 9-3    | ELECTROSTATIC DISCHARGE CONTROL          | 28   |
| 9-4    | PRECAUTIONS FOR STRONG LIGHT EXPOSURE    | 28   |
| 9-5    | STORAGE                                  | 28   |
| 9-6    | HANDLING PRECAUTIONS FOR PROTECTION FILM | 28   |
| 9-7    | APPROPRATE CONDITION FOR PUBLIC DISPLAY  | 28   |



LD840EQD

## Product Specification

## 1. General Description

The LD840EQD is a Color Active Matrix Liquid Crystal Display with an integral Light Emitting Diode (LED) backlight system. The matrix employs a-Si Thin Film Transistor as the active element. It is a transmissive display type which is operating in the normally black mode. It has a 84.04 inch diagonally measured active display area with QWUXGA resolution (2160 vertical by 3840 horizontal pixel array). Each pixel is divided into Red, Green and Blue sub-pixels or dots which are arrayed in vertical stripes. Gray scale or the luminance of the sub-pixel color is determined with a 10-bit gray scale signal for each dot. Therefore, it can present a palette of more than 1.06Billion colors.

It has been designed to apply the 10-bit 16 Lane V by One interface.

It is intended to support Public Display where high brightness, super wide viewing angle, high color gamut, high color depth and fast response time are important.

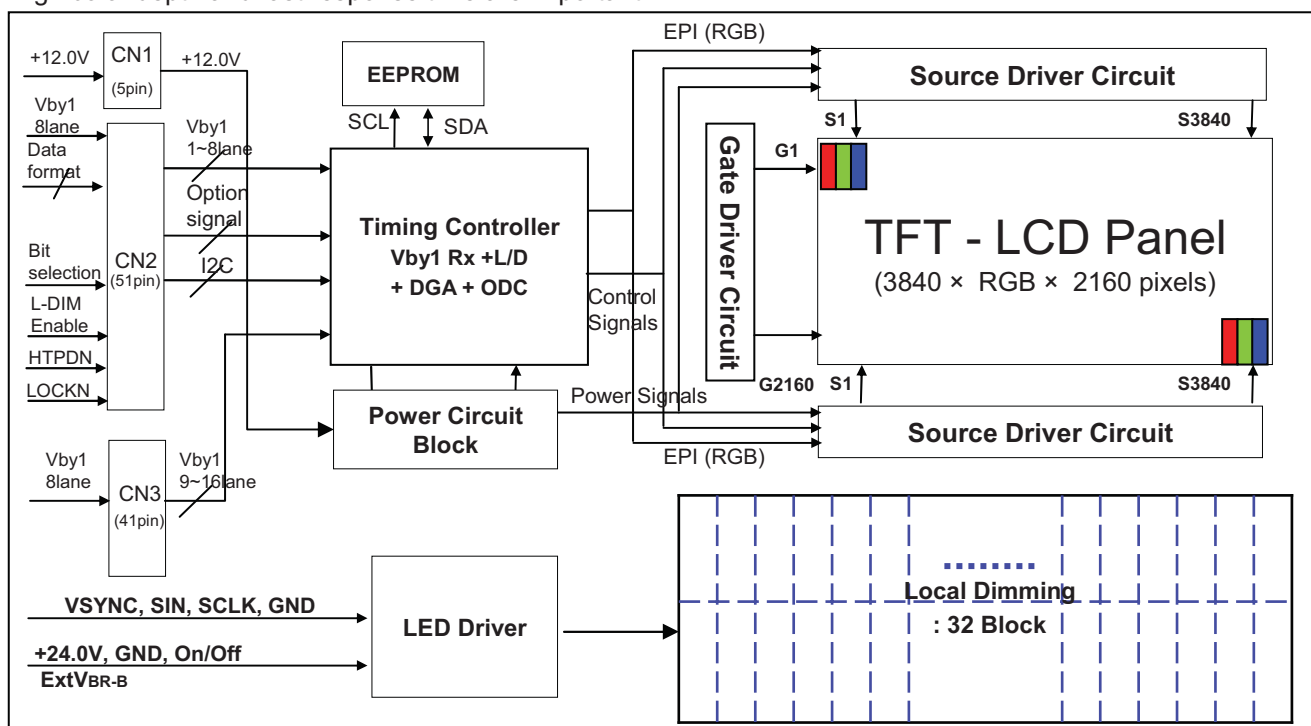

|                       |  |
|-----------------------|--|
| Active Screen Size    | 84.04 inches(2134.62 mm) diagonal  |
| Outline Dimension     | 1904.0(H) × 1096.0(V) X 15.5(B) /24.0 mm(D) (Typ.)                       |
| Pixel Pitch           | 0.4845 mm x 0.4845 mm  |
| Pixel Format          | 3840 horiz. by 2160 vert. Pixels, RGB stripe arrangement                 |
| Color Depth           | 10bit(D), 1.06Billion colors   |
| Luminance, White      | 500 cd/m <sup>2</sup> (Center 1point ,Typ.)                              |
| Viewing Angle (CR>10) | Viewing angle free ( R/L 178 (Min.), U/D 178 (Min.))                     |
| Power Consumption     | Total 398W (Typ.) [Logic= 18W, LED Driver=380W (ExtVbr_B=100% )]         |
| Weight                | 42.9 Kg (Typ.)   |
| Display Mode          | Transmissive mode, Normally black  |
| Surface Treatment     | Hard coating(3H), Anti-glare treatment of the front polarizer (Haze 10%) |
| Possible Display type | Landscape and Portrait Enalbed   |

Ver. 1.0

3 /41

LD840EQD

## Product Specification

## 2. Absolute Maximum Ratings

The following items are maximum values which, if exceeded, may cause faulty operation or permanent damage to the LCD module.

**Table 1. ABSOLUTE MAXIMUM RATINGS**

| Parameter                      |             | Symbol                             | Value |        | Unit | notes |
|--------------------------------|-------------|------------------------------------|-------|--------|------|-------|
|                                |             |                                    | Min   | Max    |      |       |
| Power Input Voltage            | LCD Circuit | VLCD                               | -0.3  | +14.0  | VDC  | 1     |
|                                | Driver      | VBL                                | -0.3  | + 27.0 | VDC  |       |
| Driver Control Voltage         | ON/OFF      | V <sub>OFF</sub> / V <sub>ON</sub> | -0.3  | +5.5   | VDC  | 1     |
|                                | Brightness  | EXTVBR-B                           | 0.0   | +5.5   | VDC  |       |
| T-Con Option Selection Voltage |             | V <sub>LOGIC</sub>                 | -0.3  | +4.0   | VDC  |       |
| Operating Temperature          |             | T <sub>OP</sub>                    | 0     | +50    | °C   | 2,3   |
| Storage Temperature            |             | T <sub>ST</sub>                    | -20   | +60    | °C   |       |
| Panel Front Temperature        |             | T <sub>SUR</sub>                   | -     | +68    | °C   | 4     |
| Operating Ambient Humidity     |             | H <sub>OP</sub>                    | 10    | 90     | %RH  | 2,3   |
| Storage Humidity               |             | H <sub>ST</sub>                    | 10    | 90     | %RH  |       |

notes :1. Ambient temperature condition ( $T_a = 25 \pm 2 \text{ }^\circ\text{C}$ )

2. Temperature and relative humidity range are shown in the figure below.

Wet bulb temperature should be Max 39°C, and no condensation of water.

3. Gravity mura can be guaranteed below 50°C condition.

4. The maximum operating temperatures is based on the test condition that the surface temperature of display area is less than or equal to 68°C with LCD module alone in a temperature controlled chamber. Thermal management should be considered in final product design to prevent the surface temperature of display area from being over 68°C. The range of operating temperature may be degraded in case of improper thermal management in final product design.

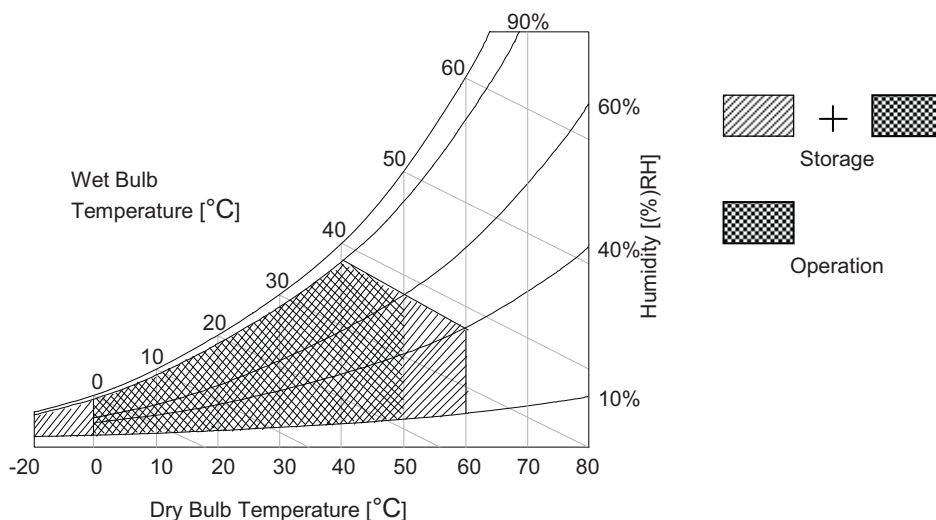

LD840EQD

## Product Specification

### 3. Electrical Specifications

#### 3-1. Electrical Characteristics

It requires two power inputs. One is employed to power for the LCD circuit. The other is used for the LED backlight and LED Driver circuit.

**Table 2. ELECTRICAL CHARACTERISTICS**

| Parameter           | Symbol            | Value |      |      | Unit | notes |
|---------------------|-------------------|-------|------|------|------|-------|
|                     |                   | Min   | Typ  | Max  |      |       |
| <b>Circuit :</b>    |                   |       |      |      |      |       |
| Power Input Voltage | V <sub>LCD</sub>  | 10.8  | 12.0 | 13.2 | Vdc  |       |
| Power Input Current | I <sub>LCD</sub>  | -     | 1500 | 1950 | mA   | 1     |
|                     |                   | -     | 4400 | 5720 | mA   | 2     |
| Power Consumption   | P <sub>LCD</sub>  | -     | 18.0 | 23.4 | Watt | 1     |
| Rush current        | I <sub>RUSH</sub> | -     | -    | 8.0  | A    | 3     |

- notes : 1. The specified current and power consumption are under the  $V_{LCD}=12.0V$ ,  $T_a=25 \pm 2^\circ C$ ,  $f_v=120Hz$  condition, and mosaic pattern(8 x 6) is displayed and  $f_v$  is the frame frequency.  
 2. The current is specified at the maximum current pattern.  
 3. The duration of rush current is about 2ms and rising time of power input is 0.5ms (min.).  
 4. Ripple voltage level is recommended under  $\pm 5\%$  of typical voltage

White : 1023 Gray  
 Black : 0 Gray

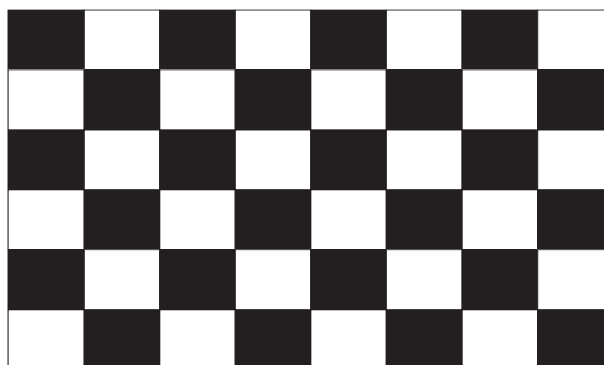
**Mosaic Pattern(8 x 6)**

LD840EQD

## Product Specification

Table 3. ELECTRICAL CHARACTERISTICS (Continue)

| Parameter                                |                              | Symbol    | Driver Board | Values |        |      | Unit | Notes                              |   |
|--|------------------------------|-----------|--------------|--------|--------|------|------|------------------------------------|---|
|  |                              |           |              | Min    | Typ    | Max  |      |                                    |   |
| LED Driver :                             |                              |           |              |        |        |      |      |                                    |   |
| Power Supply Input Voltage               |                              | VBL       |              | 22.8   | 24.0   | 25.2 | Vdc  | 1                                  |   |
| Power Supply Input Current               |                              | IBL       | Left         | -      | 7.9    | 8.5  | A    | 1                                  |   |
|  |                              |           | Right        |        | 7.9    | 8.5  |      |                                    |   |
| Power Supply Input Current (In- Rush)    |                              | In- rush  | Left         | -      | -      | 10.7 | A    | VBL = 22.8V<br>ExtVBR- B=100%<br>4 |   |
|  |                              |           | Right        | -      | -      | 10.7 |      |                                    |   |
| Power Consumption (Total)                |                              | PBL       | Left         | -      | 190    | 204  | W    | 1                                  |   |
|  |                              |           | Right        | -      | 190    | 204  |      |                                    |   |
| Input Voltage for Control System Signals | On/Off                       | On        | V on         | 2.5    | -      | 5.0  | Vdc  | On Duty<br>6                       |   |
|  |                              | Off       | V off        | - 0.3  | 0.0    | 0.7  | Vdc  |                                    |   |
|  | Brightness Adjust            | ExtVBR- B | 1            | -      | 100    | %    |      |                                    |   |
|  | PWM Frequency for NTSC & PAL | PAL       |              |        | 100    |      | Hz   |                                    | 3 |
|  |                              | NTSC      |              |        | 120    |      | Hz   |                                    | 3 |
| Pulse Duty Level (PWM)                   | High Level                   |           |              | 2.5    | -      | 3.6  | Vdc  | HIGH : on duty<br>LOW : off duty   |   |
|  | Low Level                    |           |              | 0.0    | -      | 0.7  | Vdc  |                                    |   |
| LED :                                    |                              |           |              |        |        |      |      |                                    |   |
| Life Time                                |                              |           |              | 30,000 | 50,000 |      | Hrs  | 2                                  |   |

## Notes :

- Electrical characteristics are determined after the unit has been 'ON' and stable for approximately 60 minutes at  $25\pm 2^{\circ}\text{C}$ . The specified current and power consumption are under the typical supply Input voltage 24V and VBR (ExtVBR-B : 100%), it is total power consumption.
- The life time (MTTF) is determined as the time which luminance of the LED is 50% compared to that of initial value at the typical LED current (ExtVBR-B : 100%) on condition of continuous operating in LCM state at  $25\pm 2^{\circ}\text{C}$ .
- LGD recommend that the PWM freq. is synchronized with One time harmonic of V\_sync signal of system. Though PWM frequency is over 120Hz (max 252Hz), function of LED Driver is not affected.
- The duration of rush current is about 200ms. This duration is applied to LED on time
- Even though inrush current is over the specified value, there is no problem if I<sup>2</sup>T spec of fuse is satisfied.
- Ext\_PWM Signal have to input available duty range.  
Between 99% and 100% ExtVBR-B duty have to be avoided. (  $99\% < \text{ExtVBR-B} < 100\%$  )  
But ExtVBR-B 0% and 100% is possible.

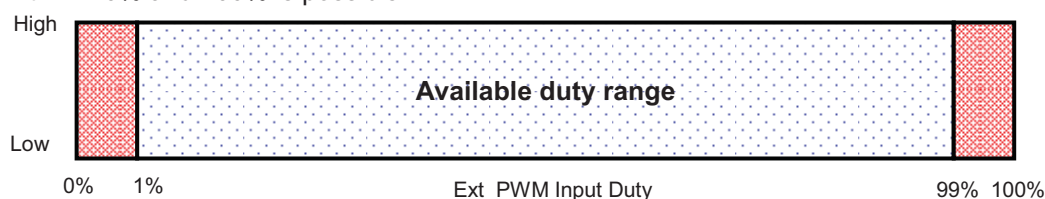

LD840EQD

## Product Specification

**3-2. Interface Connections**

This LCD module employs three kinds of interface connection, 5-pin connector, 51-pin connector and 41-pin connector are used for the module electronics and 14-pin, 12-pin connector is used for the integral backlight system.

**3-2-1. LCD Module**

- LCD Connector(CN1): SM05B-PASS-TB(manufactured by JST)
- Mating Connector : PAP-05V-S(JST) or compatible

**Table 4-1. MODULE CONNECTOR(CN1) PIN CONFIGURATION**

| No | Symbol | Description         |
|----|--------|---------------------|
| 1  | GND    | Ground              |
| 2  | GND    | Ground              |
| 3  | VLCD   | Power Supply +12.0V |
| 4  | VLCD   | Power Supply +12.0V |
| 5  | VLCD   | Power Supply +12.0V |



LD840EQD

## Product Specification

- LCD Connector(CN1): FI-RE51S-HF(manufactured by JAE)
- Mating Connector : FI-R51HL(JAE) or compatible

Table 4-2. MODULE CONNECTOR(CN2) PIN CONFIGURATION

| No | Symbol        | Description  | No | Symbol | Description             |
|----|---------------|--|----|--------|-------------------------|
| 1  | NC (Reserved) | Power Supply +12.0V (reserved)   | 27 | GND    | Ground                  |
| 2  | NC (Reserved) | Power Supply +12.0V (reserved)   | 28 | Rx0n   | V-by-One HS Data Lane 0 |
| 3  | NC (Reserved) | Power Supply +12.0V (reserved)   | 29 | Rx0p   | V-by-One HS Data Lane 0 |
| 4  | NC (Reserved) | Power Supply +12.0V (reserved)   | 30 | GND    | Ground                  |
| 5  | NC (Reserved) | Power Supply +12.0V (reserved)   | 31 | Rx1n   | V-by-One HS Data Lane 1 |
| 6  | NC (Reserved) | Power Supply +12.0V (reserved)   | 32 | Rx1p   | V-by-One HS Data Lane 1 |
| 7  | NC (Reserved) | Power Supply +12.0V (reserved)   | 33 | GND    | Ground                  |
| 8  | NC (Reserved) | Power Supply +12.0V (reserved)   | 34 | Rx2n   | V-by-One HS Data Lane 2 |
| 9  | NC            | NO CONNECTION (notes 4)  | 35 | Rx2p   | V-by-One HS Data Lane 2 |
| 10 | GND           | Ground   | 36 | GND    | Ground                  |
| 11 | GND           | Ground   | 37 | Rx3n   | V-by-One HS Data Lane 3 |
| 12 | GND           | Ground   | 38 | Rx3p   | V-by-One HS Data Lane 3 |
| 13 | GND           | Ground   | 39 | GND    | Ground                  |
| 14 | GND           | Ground   | 40 | Rx4n   | V-by-One HS Data Lane 4 |
| 15 | Data format 0 | Input Data Format [1:0] :<br>'00'=Mode1, '01'=Mode2,<br>'10'=Mode3, '11'=Mode4 | 41 | Rx4p   | V-by-One HS Data Lane 4 |
| 16 | Data format 1 |  | 42 | GND    | Ground                  |
| 17 | NC            | NO CONNECTION (notes 4)  | 43 | Rx5n   | V-by-One HS Data Lane 5 |
| 18 | SDA           | SDA<br>(For Local Dimming & Vx1 Rx reset)                                      | 44 | Rx5p   | V-by-One HS Data Lane 5 |
| 19 | SCL           | SCL<br>(For Local Dimming & Vx1 Rx reset)                                      | 45 | GND    | Ground                  |
| 20 | NC            | NO CONNECTION (notes 4)  | 46 | Rx6n   | V-by-One HS Data Lane 6 |
| 21 | Bit SEL       | 'H' or NC= 10bit(D), 'L' = 8bit  | 47 | Rx6p   | V-by-One HS Data Lane 6 |
| 22 | L-DIM Enable  | 'H' = Enable , 'L' or NC = Disable   | 48 | GND    | Ground                  |
| 23 | GND           | Ground (notes 7)   | 49 | Rx7n   | V-by-One HS Data Lane 7 |
| 24 | GND           | Ground   | 50 | Rx7p   | V-by-One HS Data Lane 7 |
| 25 | HTPDN         | Hot plug detect  | 51 | GND    | Ground                  |
| 26 | LOCKN         | Lock detect  | -  | -      | -                       |

## notes

- All GND (ground) pins should be connected together to the LCD module's metal frame.
- #1~#8 NC (No connection) : These pins are used for back up power source, V<sub>LCD</sub> (power input) .  
These pins are should be connected together.
- All Input levels of V-by-One signals are based on the V-by-One HS Standard Version 1.3.
- #9,#17 & #20 NC (No Connection) : These pins are used only for LGD (Do not connect)
- Specific pin (#22) is used for Local Dimming function of the LCD module.  
If not used, these pins are no connection. (Please see the **Appendix IV-3** for more information.)
- About spcific pin (#15,#16) , Please see the **Appendix VII**.
- Specific pin No. #23 is used for "No signal detection" of system signal interface.  
It should be GND for NSB (No Signal Black) while the system interface signal is not.  
If this pin is "H" or "NC", LCD Module displays AGP (Auto Generation Pattern).
- Specific pin (pin No. #18, #19) is used for Controlling Local Dimming register & Vx1 Rx Reset in the LCM Module.

LD840EQD

## Product Specification

- LCD Connector (CN2) : FI-RE41S-HF (manufactured by JAE)
- Mating Connector : FI-RE41HL or compatible

Table 4-3. MODULE CONNECTOR(CN3) PIN CONFIGURATION

| No | Symbol | Description              | No | Symbol | Description              |
|----|--------|--------------------------|----|--------|--------------------------|
| 1  | GND    | Ground                   | 22 | GND    | Ground                   |
| 2  | Rx8n   | V-by-One HS Data Lane 8  | 23 | Rx15n  | V-by-One HS Data Lane 15 |
| 3  | Rx8p   | V-by-One HS Data Lane 8  | 24 | Rx15p  | V-by-One HS Data Lane 15 |
| 4  | GND    | Ground                   | 25 | GND    | Ground                   |
| 5  | Rx9n   | V-by-One HS Data Lane 9  | 26 | NC     | NO CONNECTION            |
| 6  | Rx9p   | V-by-One HS Data Lane 9  | 27 | NC     | NO CONNECTION            |
| 7  | GND    | Ground                   | 28 | NC     | NO CONNECTION            |
| 8  | Rx10n  | V-by-One HS Data Lane 10 | 29 | NC     | NO CONNECTION            |
| 9  | Rx10p  | V-by-One HS Data Lane 10 | 30 | NC     | NO CONNECTION            |
| 10 | GND    | Ground                   | 31 | NC     | NO CONNECTION            |
| 11 | Rx11n  | V-by-One HS Data Lane 11 | 32 | NC     | NO CONNECTION            |
| 12 | Rx11p  | V-by-One HS Data Lane 11 | 33 | NC     | NO CONNECTION            |
| 13 | GND    | Ground                   | 34 | NC     | NO CONNECTION            |
| 14 | Rx12n  | V-by-One HS Data Lane 12 | 35 | NC     | NO CONNECTION            |
| 15 | Rx12p  | V-by-One HS Data Lane 12 | 36 | NC     | NO CONNECTION            |
| 16 | GND    | Ground                   | 37 | NC     | NO CONNECTION            |
| 17 | Rx13n  | V-by-One HS Data Lane 13 | 38 | NC     | NO CONNECTION            |
| 18 | Rx13p  | V-by-One HS Data Lane 13 | 39 | NC     | NO CONNECTION            |
| 19 | GND    | Ground                   | 40 | NC     | NO CONNECTION            |
| 20 | Rx14n  | V-by-One HS Data Lane 14 | 41 | NC     | NO CONNECTION            |
| 21 | Rx14p  | V-by-One HS Data Lane 14 | -  |        |                          |

- notes : 1. All GND (ground) pins should be connected together to the LCD module's metal frame.  
2. #26~#41 NC (No Connection) : These pins are used only for LGD (Do not connect)

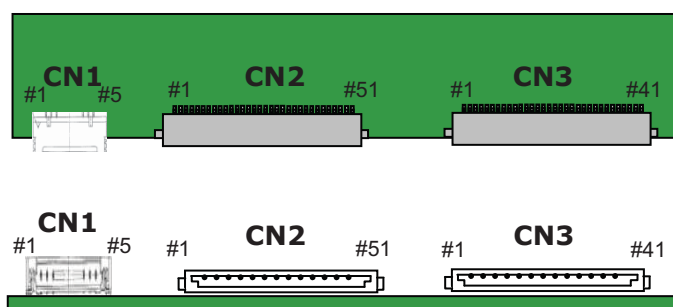

Rear view of LCM

LD840EQD

## Product Specification

**3-2-2. Backlight Module**

Master

-LED Driver Connector

: 20022WR - H14B2(Yeonho) , 20022WR-H12B2(Yeonho)

- Mating Connector

: 20022HS-H14B2(Yeonho),20022HS-H12B2(Yeonho) or Compatible

**Table 5-1. LED DRIVER CONNECTOR PIN CONFIGURATION**

| Pin No | Symbol   | Description<br>(CN_A1/CN_B1) | Description<br>(CN_A2/CN_B2) | Note |
|--------|----------|------------------------------|------------------------------|------|
| 1      | VBL      | Power Supply +24.0V          | Power Supply +24.0V          |      |
| 2      | VBL      | Power Supply +24.0V          | Power Supply +24.0V          |      |
| 3      | VBL      | Power Supply +24.0V          | Power Supply +24.0V          |      |
| 4      | VBL      | Power Supply +24.0V          | Power Supply +24.0V          |      |
| 5      | VBL      | Power Supply +24.0V          | Power Supply +24.0V          |      |
| 6      | GND      | Backlight Ground             | Backlight Ground             | 1    |
| 7      | GND      | Backlight Ground             | Backlight Ground             |      |
| 8      | GND      | Backlight Ground             | Backlight Ground             |      |
| 9      | GND      | Backlight Ground             | Backlight Ground             |      |
| 10     | GND      | Backlight Ground             | Backlight Ground             |      |
| 11     | Status   | Backlight Status             | Don't care                   | 2    |
| 12     | VON/OFF  | Backlight ON/OFF control     | Don't care                   |      |
| 13     | NC       | Don't care                   |                              |      |
| 14     | EXTVBR_B | External PWM                 |                              | 3    |

notes : 1. GND should be connected to the LCD module's metal frame.

2. Normal : Low (under 0.7V) / Abnormal : Open

3. High : on duty / Low : off duty, Pin#14 can be opened. ( if Pin #14 is open , EXTVBR-B is 100% )

4. Each impedance of pin #12 and 14 is over 50 [KΩ] .

## ◆ Rear view of LCM

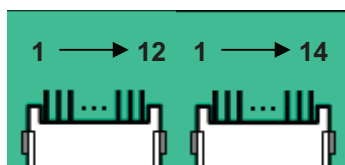
**Board B**

CN\_B2      CN\_B1

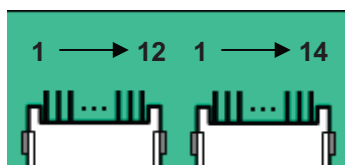
**Board A**

CN\_A2      CN\_A1

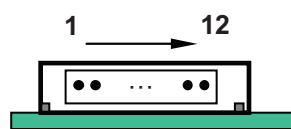

## ◆ Status

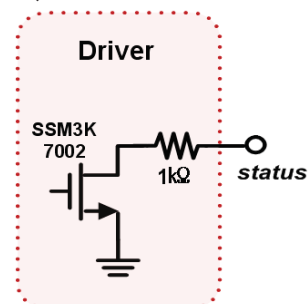

LD840EQD

## Product Specification

## 3-3. Signal Timing Specifications

Table 6 shows the signal timing required at the input of the Vx1 transmitter. All of the interface signal timings should be satisfied with the following specification for normal operation.

Table 6. TIMING TABLE (DE Only Mode)

| ITEM       |                | Symbol   | Min            | Typ            | Max            | Unit      | Note    |
|------------|----------------|----------|----------------|----------------|----------------|-----------|---------|
| Horizontal | Display Period | $t_{HV}$ | 240            | 240            | 240            | $t_{CLK}$ | 3840/16 |
|            | Blank          | $t_{HB}$ | 25             | 35             | 60             | $t_{CLK}$ | 1       |
|            | Total          | $t_{HP}$ | 265            | 275            | 300            | $t_{CLK}$ |         |
| Vertical   | Display Period | $t_{VV}$ | 2160           | 2160           | 2160           | Lines     |         |
|            | Blank          | $t_{VB}$ | 40<br>(456)    | 90<br>(540)    | 172<br>(600)   | Lines     | 1       |
|            | Total          | $t_{VP}$ | 2200<br>(2616) | 2250<br>(2700) | 2332<br>(2760) | Lines     |         |

| ITEM      |            | Symbol    | Min         | Typ          | Max          | Unit | Note               |
|-----------|------------|-----------|-------------|--------------|--------------|------|--------------------|
| Frequency | DCLK       | $f_{CLK}$ | 67          | 74.25        | 78.00        | MHz  | 1188/16            |
|           | Horizontal | $f_H$     | 244         | 270          | 280          | KHz  | 1                  |
|           | Vertical   | $f_V$     | 108<br>(95) | 120<br>(100) | 122<br>(104) | Hz   | 2<br>NTSC<br>(PAL) |

notes: 1. The input of HSYNC & VSYNC signal does not have an effect on normal operation (DE Only Mode).  
If you use spread spectrum of EMI, add some additional clock to minimum value for clock margin.

2. The performance of the electro-optical characteristics may be influenced by variance of the vertical refresh rate and the horizontal frequency

※ Timing should be set based on clock frequency.

## Product Specification

## 3-4. V by One input signal Characteristics

## 3-4-1. V by One Input Signal Timing Diagram

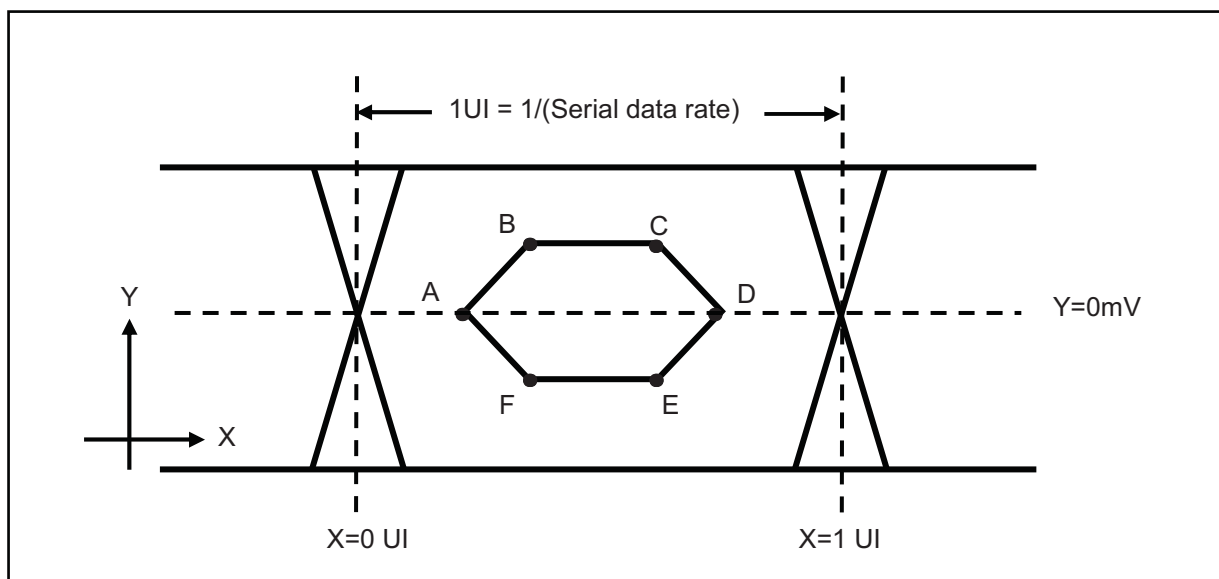

Table7. Eye Mask Specification

|   | X[UI]      | Note | Y[mV] | Note |
|---|------------|------|-------|------|
| A | 0.25 (max) | 2    | 0     | -    |
| B | 0.3 (max)  | 2    | 50    | 3    |
| C | 0.7(min)   | 3    | 50    | 3    |
| D | 0.75(min)  | 3    | 0     | -    |
| E | 0.7(min)   | 3    | -50   | 3    |
| F | 0.3(max)   | 2    | -50   | 3    |

- notes
- All Input levels of V by One signals are based on the V by One HS Standard Ver. 1.3
  - This is allowable maximum value.
  - This is allowable minimum value.
  - The eye diagram is measured by the oscilloscope and receiver CDR characteristic must be emulated.
    - PLL bandwidth : 11 Mhz
    - Damping Factor : 1

Product Specification

3-4-2. V by One Input Signal Characteristics

1) DC Specification

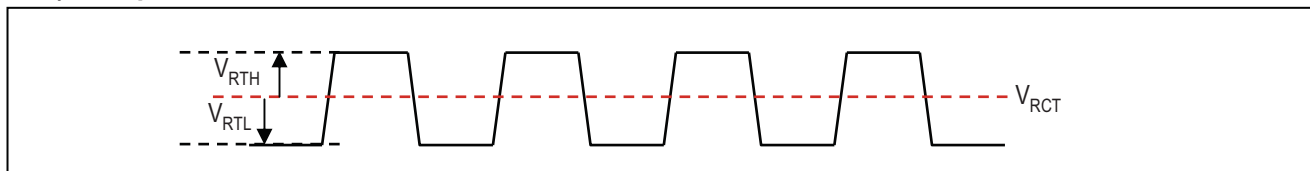

| Description                           | Symbol    | Min | Max | Unit | notes |
|---------------------------------------|-----------|-----|-----|------|-------|
| CML Differential input High threshold | $V_{RTH}$ | -   | 50  | mV   | -     |
| CML Differential input Low threshold  | $V_{RTL}$ | -50 | -   | mV   | -     |
| CML Common mode Bias Voltage          | $V_{RCT}$ | 0.6 | 0.8 | V    | -     |

2) AC Specification

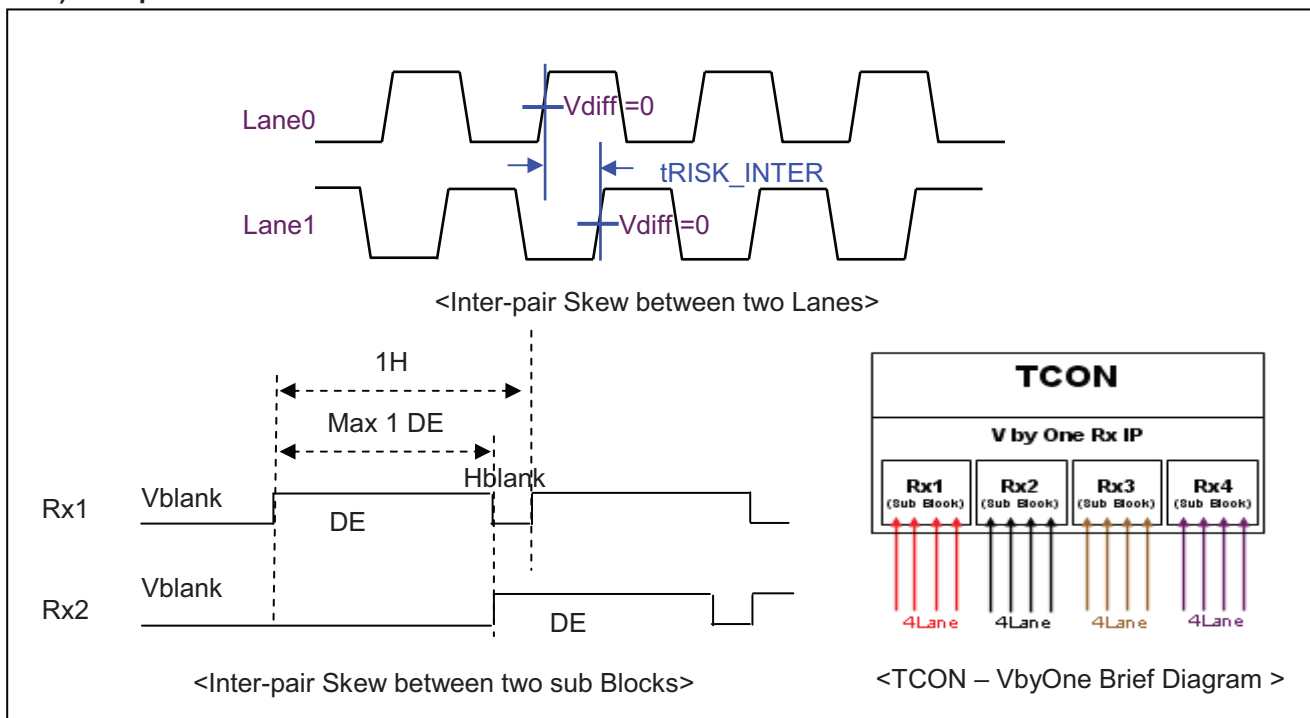

| Description                                 | Symbol            | Min | Max | Unit | notes |
|---|-------------------|-----|-----|------|-------|
| Allowable inter-pair skew between lanes     | $t_{RISK\_INTER}$ | -   | 5   | UI   | 1,3   |
| Allowable iner-pair skew between sub-blocks | $t_{RISK\_BLOCK}$ | -   | 1   | DE   | 1,4   |

Notes 1.1UI = 1/serial data rate

2. it is the time difference between the true and complementary single-ended signals.
3. it is the time difference of the differential voltage between any two lanes in one sub block.
4. it is the time difference of the differential voltage between any two blocks in one IP.

## Product Specification

## 3-5. Color Data Reference

The brightness of each primary color (red, green, blue) is based on the 10bit or 8bit gray scale data input for the color. The higher binary input, the brighter the color. Table 8 provides a reference for color versus data input.

Table 8. COLOR DATA REFERENCE

| Packer input & Unpacker output |       | 30bpp RGB (10bit) | 24bpp RGB (8bit) |
|--------------------------------|-------|-------------------|------------------|
| Byte0                          | D[0]  | R[2]              | R[0]             |
|                                | D[1]  | R[3]              | R[1]             |
|                                | D[2]  | R[4]              | R[2]             |
|                                | D[3]  | R[5]              | R[3]             |
|                                | D[4]  | R[6]              | R[4]             |
|                                | D[5]  | R[7]              | R[5]             |
|                                | D[6]  | R[8]              | R[6]             |
| Byte1                          | D[7]  | R[9]              | R[7]             |
|                                | D[8]  | G[2]              | G[0]             |
|                                | D[9]  | G[3]              | G[1]             |
|                                | D[10] | G[4]              | G[2]             |
|                                | D[11] | G[5]              | G[3]             |
|                                | D[12] | G[6]              | G[4]             |
|                                | D[13] | G[7]              | G[5]             |
| Byte2                          | D[14] | G[8]              | G[6]             |
|                                | D[15] | G[9]              | G[7]             |
|                                | D[16] | B[2]              | B[0]             |
|                                | D[17] | B[3]              | B[1]             |
|                                | D[18] | B[4]              | B[2]             |
|                                | D[19] | B[5]              | B[3]             |
|                                | D[20] | B[6]              | B[4]             |
| Byte3                          | D[21] | B[7]              | B[5]             |
|                                | D[22] | B[8]              | B[6]             |
|                                | D[23] | B[9]              | B[7]             |
|                                | D[24] | Don't care        |                  |
|                                | D[25] | Don't care        |                  |
|                                | D[26] | B[0]              |                  |
|                                | D[27] | B[1]              |                  |
|                                | D[28] | G[0]              |                  |
|                                | D[29] | G[1]              |                  |
|                                | D[30] | R[0]              |                  |
|                                | D[31] | R[1]              |                  |

Notes 1. 30bpp RGB (10bit) is 4 byte mode, otherwise (24bpp RGB) 3byte mode

LD840EQD

## Product Specification

## 3-6. Power Sequence

## 3-6-1. LCD Driving circuit

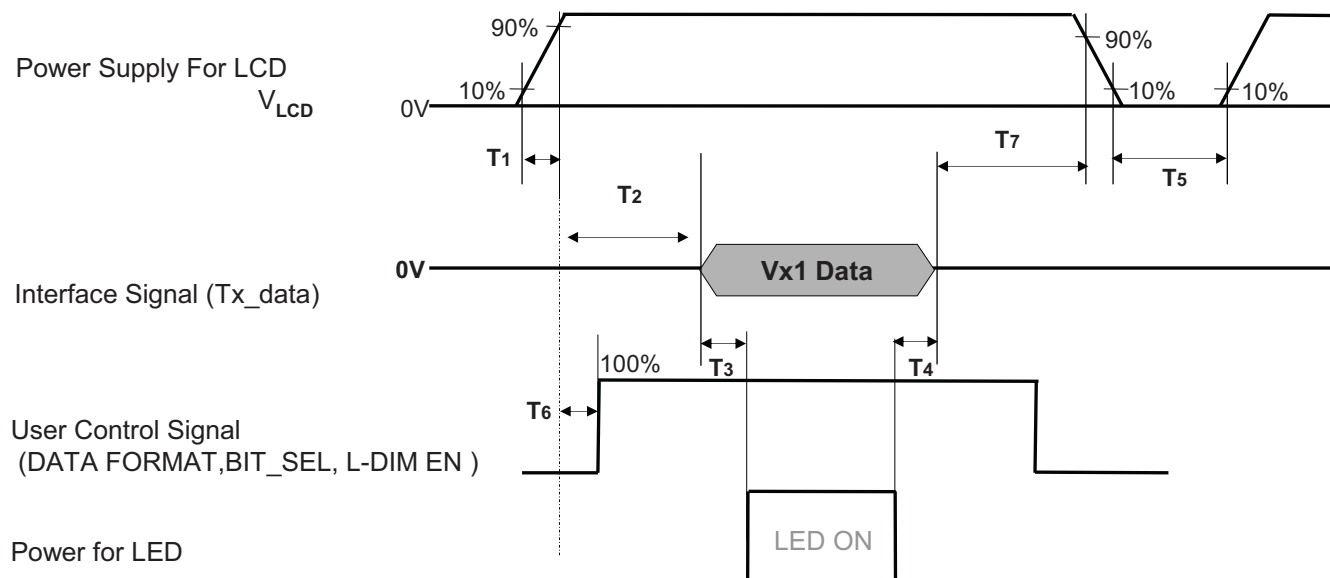

Table 9. POWER SEQUENCE

| Parameter | Value |     |     | Unit | notes |
|-----------|-------|-----|-----|------|-------|
|           | Min   | Typ | Max |      |       |
| T1        | 0.5   | -   | 20  | ms   | 1     |
| T2        | 0     | -   | -   | ms   | 2     |
| T3        | 400   | -   | -   | ms   | 3     |
| T4        | 200   | -   | -   | ms   | 3     |
| T5        | 1.0   | -   | -   | s    | 4     |
| T6        | 0     | -   | T2  | ms   | 5     |
| T7        | 0     | -   | -   | s    | 6     |

- notes :
1. Even though T1 is over the specified value, there is no problem if I2T Spec. of fuse is satisfied.
  2. If T2 is satisfied with specification after removing V-by-One Cable, there is no problem.
  3. The T3 / T4 is recommended value, the case when failed to meet a minimum specification, abnormal display would be shown. There is no reliability problem.
  4. T5 should be measured after the Module has been fully discharged between power off and on period.
  5. If the on time of signals (Interface signal and user control signals) precedes the on time of Power ( $V_{LCD}$ ), it will be happened abnormal display. When T6 is NC status, T6 doesn't need to be measured.
  6. 6. It is recommendation specification that T7 has to be 0ms as a minimum value.
- ※ Please avoid floating state of interface signal at invalid period.
  - ※ When the power supply for LCD (VLCD) is off, be sure to pull down the valid and invalid data to 0V.
  - ※ There is no problem even though LOCKN/HTPDN Signal is on before T1.



Product Specification

3-6-2. Sequence for LED Driver

Power Supply For LED Driver

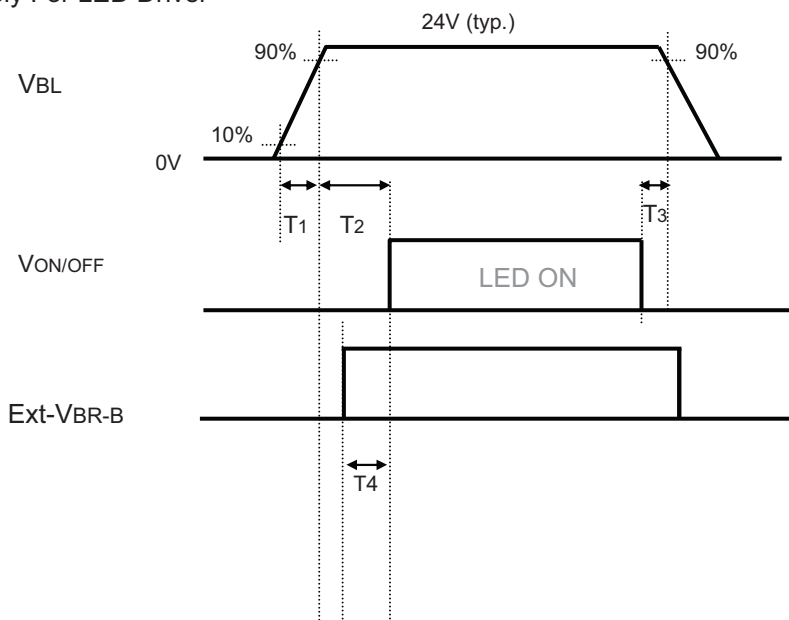

3-6-3. Dip condition for LED Driver

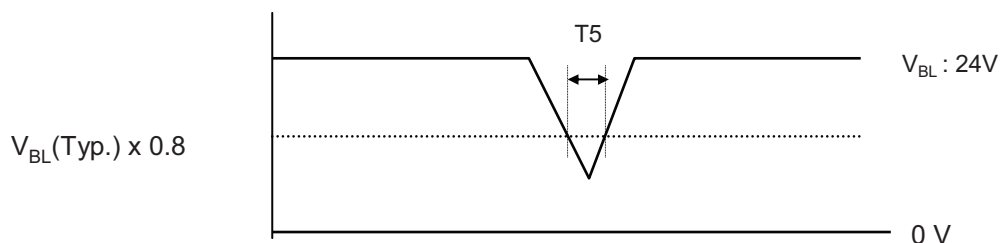

Table 10. Power Sequence for LED Driver

| Parameter | Values |     |     | Units | Remarks                  |
|-----------|--------|-----|-----|-------|--------------------------|
|           | Min    | Typ | Max |       |                          |
| T1        | 20     | -   | -   | ms    | 1                        |
| T2        | 500    | -   | -   | ms    |                          |
| T3        | 10     | -   | -   | ms    |                          |
| T4        | 0      | -   | -   | ms    |                          |
| T5        | -      | -   | 10  | ms    | $V_{BL}(Typ) \times 0.8$ |

notes : 1. T1 describes rising time of 0V to 24V and this parameter does not applied at restarting time.  
Even though T1 is over the specified value, there is no problem if I<sup>2</sup>T spec of fuse is satisfied.

LD840EQD

## Product Specification

## 4. Optical Specification

Optical characteristics are determined after the unit has been 'ON' and stable in a dark environment at  $25 \pm 2^\circ\text{C}$ . The values are specified at distance 50cm from the LCD surface at a viewing angle of  $\Phi$  and  $\theta$  equal to  $0^\circ$ . FIG. 1 shows additional information concerning the measurement equipment and method.

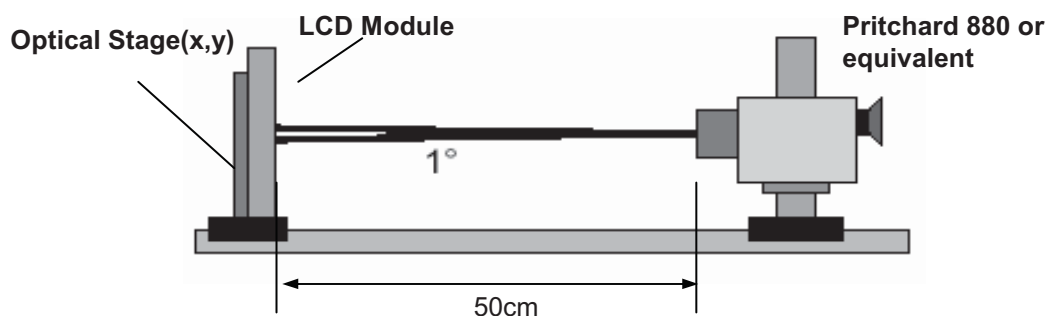

FIG. 1 Optical Characteristic Measurement Equipment and Method

$T_a = 25 \pm 2^\circ\text{C}$ ,  $V_{\text{LCD}} = 12.0\text{V}$ ,  $f_v = 120\text{Hz}$ ,  $D_{\text{clk}} = 74.25\text{MHz}$ ,  
 $\text{EXTV}_{\text{BR-B}} = 100\%$

Table 11. OPTICAL CHARACTERISTICS

| Parameter                      | Symbol                     | Value                    |              |       | Unit            | notes  |   |
|--------------------------------|----------------------------|--------------------------|--------------|-------|-----------------|--------|---|
|                                |                            | Min                      | Typ          | Max   |                 |        |   |
| Contrast Ratio                 | CR                         | 1000                     | 1400         | -     |                 | 1      |   |
| Surface Luminance, white       | $L_{\text{WH}}$            | 400                      | 500          |       | $\text{cd/m}^2$ | 2      |   |
| Luminance Variation            | $\delta_{\text{WHITE}}$ 5P |                          |              | 1.35  |                 | 3      |   |
| Response Time                  | Gray-to-Gray               | G to G                   | -            | 12    | 18              | ms     | 4 |
|                                | Uniformity                 | $\delta_{\text{G TO G}}$ | -            | -     | 1               |        | 5 |
| Color Coordinates<br>[CIE1931] | RED                        | Rx                       |              | 0.645 |                 |        |   |
|                                |                            | Ry                       |              | 0.335 |                 |        |   |
|                                | GREEN                      | Gx                       |              | 0.300 |                 |        |   |
|                                |                            | Gy                       | Typ<br>-0.03 | 0.620 | Typ<br>+0.03    |        |   |
|                                | BLUE                       | Bx                       |              | 0.150 |                 |        |   |
|                                |                            | By                       |              | 0.060 |                 |        |   |
| WHITE                          | Wx                         |                          | 0.279        |       |                 |        |   |
|                                | Wy                         |                          | 0.292        |       |                 |        |   |
| Color Temperature              |                            |                          | 10,000       |       | K               |        |   |
| Color Gamut                    |                            |                          | 72           |       | %               |        |   |
| Viewing<br>Angle (CR >10)      | right( $\phi=0^\circ$ )    | $\theta_r$ (x axis)      | 89           | -     | -               | degree | 5 |
|                                | left ( $\phi=180^\circ$ )  | $\theta_l$ (x axis)      | 89           | -     | -               |        |   |
|                                | up ( $\phi=90^\circ$ )     | $\theta_u$ (y axis)      | 89           | -     | -               |        |   |
|                                | down ( $\phi=270^\circ$ )  | $\theta_d$ (y axis)      | 89           | -     | -               |        |   |
| Gray Scale                     |                            |                          | -            | -     | -               |        | 6 |

LD840EQD

## Product Specification

notes : 1. Contrast Ratio(CR) is defined mathematically as :

CR(Contrast Ratio) = Maximum CR<sub>n</sub> (n=1, 2, 3, 4, 5)

$$CR_n = \frac{\text{Surface Luminance at position n with all white pixels}}{\text{Surface Luminance at position n with all black pixels}}$$

n = the Position number(1, 2, 3, 4, 5). For more information, see FIG 2.

2. Surface luminance is determined after the unit has been 'ON' and 1 Hour after lighting the backlight in a dark environment at 25± 2°C. Surface luminance is the luminance value at center 1-point across the LCD surface 50cm from the surface with all pixels displaying white.

For more information see the FIG. 2.

3. The variation in surface luminance, δ WHITE is defined as :

$$\delta \text{ WHITE}(5P) = \text{Maximum}(L_{on1}, L_{on2}, L_{on3}, L_{on4}, L_{on5}) / \text{Minimum}(L_{on1}, L_{on2}, L_{on3}, L_{on4}, L_{on5})$$

Where L<sub>on1</sub> to L<sub>on5</sub> are the luminance with all pixels displaying white at 5 locations .

For more information, see the FIG. 2.

4. Response time is the time required for the display to transit from G(N) to G(M) (Rise Time, Tr<sub>R</sub>) and from G(M) to G(N) (Decay Time, Tr<sub>D</sub>). For additional information see the FIG. 3. (N<M)

※ G to G Spec stands for average value of all measured points.

Photo Detector : RD-80S / Field : 2°

※ . Gray to Gray Response time uniformity is Reference data. Appendix VI-1/ VI-2

5. Viewing angle is the angle at which the contrast ratio is greater than 10. The angles are determined for the horizontal or x axis and the vertical or y axis with respect to the z axis which is normal to the LCD module surface. For more information, see the FIG. 4.

6. Gray scale specification

Gamma Value is approximately 2.2. For more information, see the Table 12.

Table 12. GRAY SCALE SPECIFICATION

| Gray Level | Luminance [%] (Typ) |
|------------|---------------------|
| L0         | 0.07                |
| L63        | 0.27                |
| L127       | 1.04                |
| L191       | 2.49                |
| L255       | 4.68                |
| L319       | 7.66                |
| L383       | 11.5                |
| L447       | 16.1                |
| L511       | 21.6                |
| L575       | 28.1                |
| L639       | 35.4                |
| L703       | 43.7                |
| L767       | 53.0                |
| L831       | 63.2                |
| L895       | 74.5                |
| L959       | 86.7                |
| L1023      | 100                 |

LD840EQD

## Product Specification

Measuring point for surface luminance & measuring point for luminance variation.

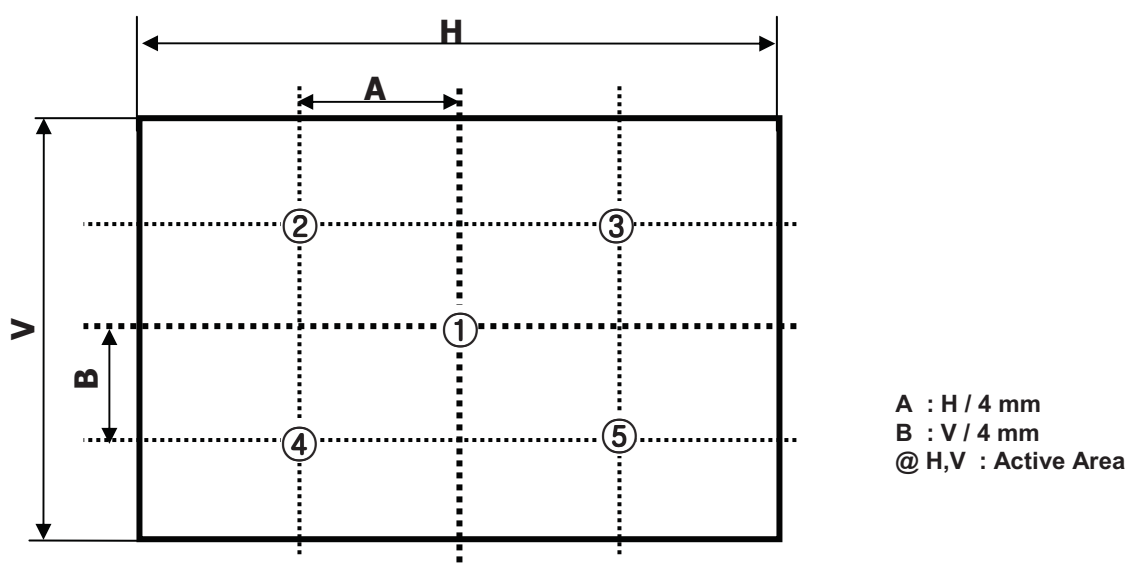

FIG. 2 5 Points for Luminance Measure

Response time is defined as the following figure and shall be measured by switching the input signal for "Gray(N)" and "Gray(M)".

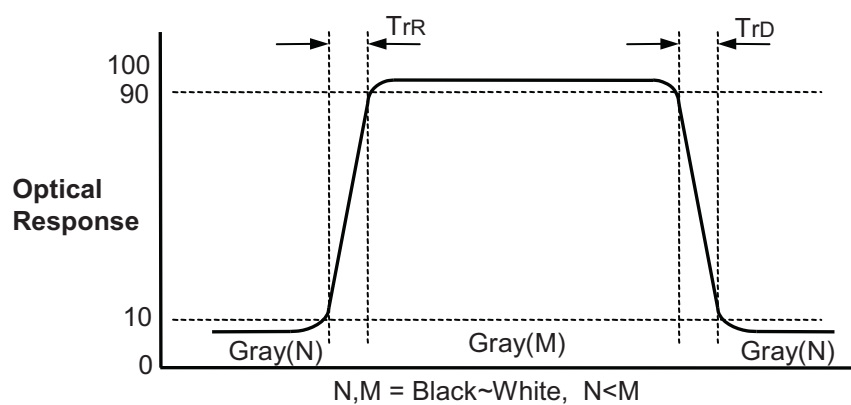

FIG. 3 Response Time

LD840EQD

## Product Specification

Dimension of viewing angle range

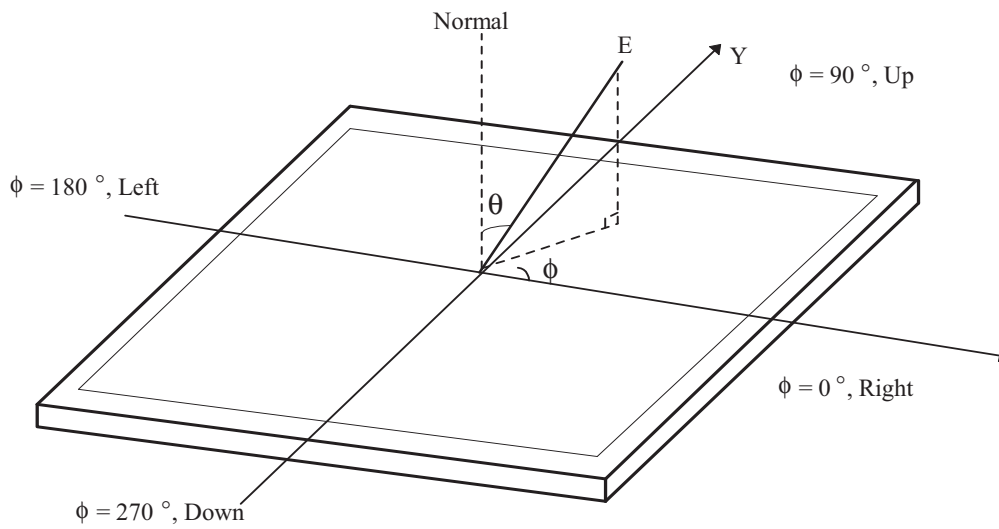

FIG. 4 Viewing Angle

LD840EQD

## Product Specification

**5. Mechanical Characteristics**

Table 13 provides general mechanical characteristics.

**Table 13. MECHANICAL CHARACTERISTICS**

| Item                | Value                         |            |
|---------------------|-------------------------------|------------|
| Outline Dimension   | Horizontal                    | 1904.0 mm  |
|                     | Vertical                      | 1096.0 mm  |
|                     | Depth                         | 15.5 mm    |
| Bezel Area          | Horizontal                    | 1871.0 mm  |
|                     | Vertical                      | 1057.0 mm  |
| Active Display Area | Horizontal                    | 1860.48 mm |
|                     | Vertical                      | 1046.52 mm |
| Weight              | 42.9Kg (Typ.), 44.4 kg (Max.) |            |

notes : Please refer to a mechanical drawing in terms of tolerance at the next page.



LD840EQD

Product Specification

[ REAR VIEW ]

Set : Top

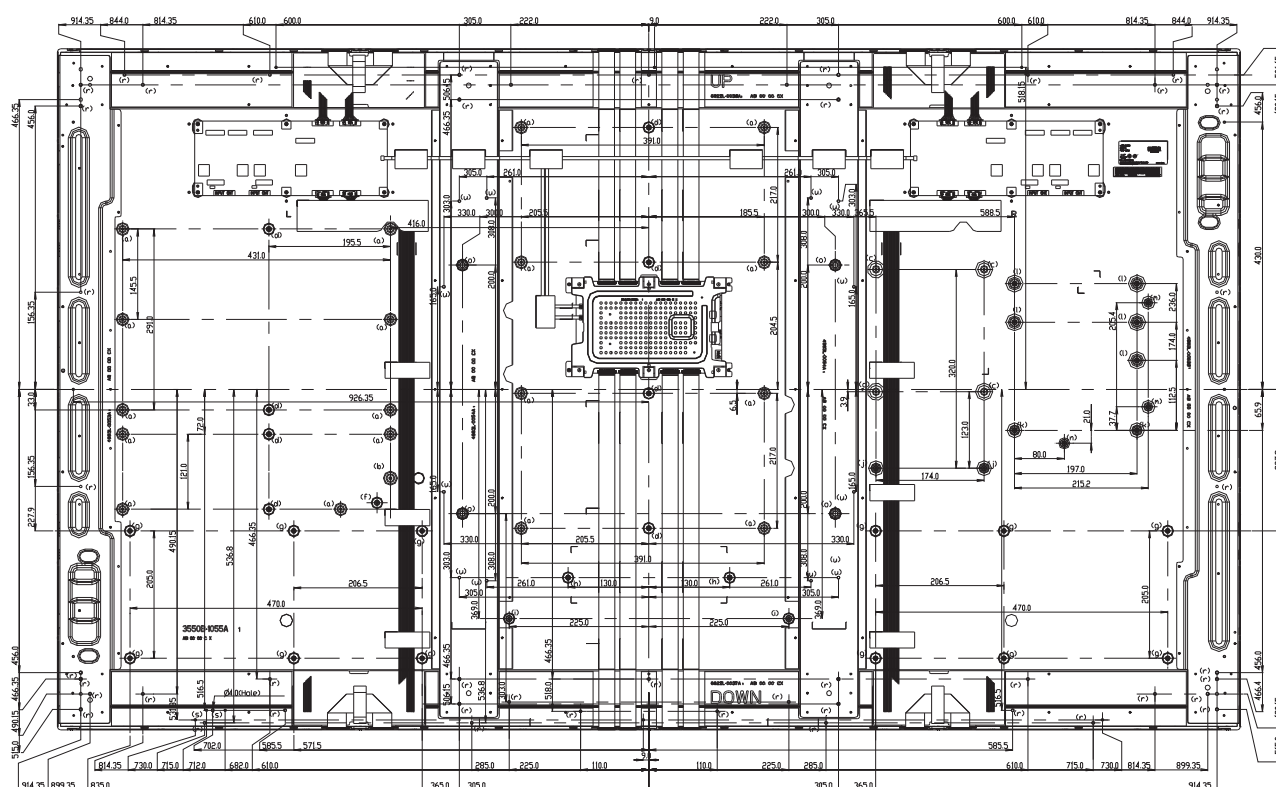

Set : Down

| ITEM | TAP  | Depth (mm)  | Torque (kgf.cm) | Notes         |
|------|------|---|-----------------|---------------|
| (a)  | M3.0 | Max 4.0   | 5.0             | Emboss        |
| (b)  | M4.0 | Max 4.0   | 6.0             | Emboss        |
| (c)  | M3.0 | Max 5.5   | 5.0             | Emboss        |
| (d)  | M3.0 | Max 4.0   | 8.0             | Pem_nut(1)    |
| (f)  | M3.0 | Max 13.4  | 8.0             | Pem_nut(3)    |
| (g)  | M3.0 | Max 12.0  | 8.0             | Pem_nut(4)    |
| (h)  | M4.0 | Max 11.0  | 10.0            | Pem_nut(5)    |
| (i)  | M4.0 | Max 11.0  | 10.0            | Pem_nut(6)    |
| (j)  | M3.0 | Max 6.4   | 8.0             | Pem_nut(1)    |
| (k)  | M3.0 | Max 8.3   | 8.0             | Pem_nut(7)    |
| (l)  | M3.0 | Max 8.3   | 8.0             | Pem_nut(8)    |
| (m)  | M3.0 | Max 6.0   | 8.0             | Pem_nut(9)    |
| (n)  | M3.0 | Max 4.7   | 8.0             | Pem_nut(9)    |
| (o)  | M8.0 | Max 19.8  | 12.0            | Pem_nut(10)   |
| (p)  | M3.0 | Max 15.8  | 8.0             | Pem_nut(11)   |
| (q)  | M3.0 | Max 13.3  | 8.0             | Pem_nut(11)   |
| (r)  | M4.0 | Max 7.5   | 6.0             | Rear Tap      |
| (s)  | M3.0 | Max 8.0   | 5.0             | Side Tap(1)   |
| (t)  | M3.0 | Min 7.2 - Max 7.6 -<br>Max 9.0<br>Top Section<br>(5.7mm-10.3mm) | 5.0             | Side Tap(2)   |
| (w)  | M4.0 | Max 6.0   | 10.0            | Center Tap(1) |



LD840EQD

## Product Specification

**6. Reliability****Table 14. ENVIRONMENT TEST CONDITION**

| No. | Test Item                                | Condition                      |
|-----|--|--------------------------------|
| 1   | High temperature storage test            | Ta= 60°C 240h                  |
| 2   | Low temperature storage test             | Ta= -20°C 240h                 |
| 3   | High temperature operation test          | Ta= 50°C 50%RH 240h            |
| 4   | Low temperature operation test           | Ta= 0°C 240h                   |
| 5   | Vibration test<br>(non-operating)        | No Guarantee                   |
| 6   | Shock test<br>(non-operating)            | No Guarantee                   |
| 7   | Humidity condition Operation             | Ta= 40 °C ,90%RH               |
| 8   | Altitude operating<br>storage / shipment | 0 - 15,000 ft<br>0 - 40,000 ft |

notes : Before and after Reliability test, LCM should be operated with normal function.

## Product Specification

## 7. International Standards

### 7-1. Safety

- a) UL 60950-1, Underwriters Laboratories Inc.  
Information Technology Equipment - Safety - Part 1 : General Requirements.
- b) CAN/CSA C22.2 No.60950-1-07, Canadian Standards Association.  
Information Technology Equipment - Safety - Part 1 : General Requirements.
- c) EN 60950-1, European Committee for Electro technical Standardization (CENELEC).  
Information Technology Equipment - Safety - Part 1 : General Requirements.
- d) IEC 60950-1, The International Electro technical Commission (IEC).  
Information Technology Equipment - Safety - Part 1 : General Requirements.  
(Including report of IEC60825-1:2001 clause 8 and clause 9)

notes

#### 1. Laser (LED Backlight) Information

|  |
|--|
| Class 1M LED Product<br>IEC60825-1 : 2001<br>Embedded LED Power (Class 1M) |
|--|

#### 2. Caution

- : LED inside.
- Class 1M laser (LEDs) radiation when open.
- Do not open while operating.

### 7-2. EMC

- a) ANSI C63.4 "American National Standard for Methods of Measurement of Radio-Noise Emissions from Low-Voltage Electrical and Electronic Equipment in the Range of 9 kHz to 40 GHz." American National Standards Institute (ANSI), 2003.
- b) CISPR 22 "Information technology equipment – Radio disturbance characteristics – Limit and methods of measurement." International Special Committee on Radio Interference (CISPR), 2005.
- c) CISPR 13 "Sound and television broadcast receivers and associated equipment – Radio disturbance characteristics – Limits and method of measurement." International Special Committee on Radio Interference (CISPR), 2006.

### 7-3. Environment

- a) RoHS, Directive 2002/95/EC of the European Parliament and of the council of 27 January 2003

LD840EQD

## Product Specification

## 8. Packing

### 8-1. Information of LCM Label

#### a) Lot Mark

|   |   |   |   |   |   |   |   |   |   |   |   |   |
|---|---|---|---|---|---|---|---|---|---|---|---|---|
| A | B | C | D | E | F | G | H | I | J | K | L | M |
|---|---|---|---|---|---|---|---|---|---|---|---|---|

A,B,C : SIZE(INCH)  
E : MONTH

D : YEAR  
F ~ M : SERIAL NO.

#### Note

##### 1. YEAR

|      |      |      |      |      |      |      |      |      |      |      |
|------|------|------|------|------|------|------|------|------|------|------|
| Year | 2011 | 2012 | 2013 | 2014 | 2015 | 2016 | 2017 | 2018 | 2019 | 2020 |
| Mark | A    | B    | C    | D    | E    | F    | G    | H    | J    | K    |

##### 2. MONTH

|       |     |     |     |     |     |     |     |     |     |     |     |     |
|-------|-----|-----|-----|-----|-----|-----|-----|-----|-----|-----|-----|-----|
| Month | Jan | Feb | Mar | Apr | May | Jun | Jul | Aug | Sep | Oct | Nov | Dec |
| Mark  | 1   | 2   | 3   | 4   | 5   | 6   | 7   | 8   | 9   | A   | B   | C   |

#### b) Location of Lot Mark

Serial NO. is printed on the label. The label is attached to the backside of the LCD module.  
This is subject to change without prior notice.

### 8-2. Packing Form

a) Package quantity in one Pallet : 6 pcs

b) Pallet Size : 2280 mm(W) X 780 mm(D) X 1424 mm(H)

## Product Specification

## 9. Precautions

Please pay attention to the followings when you use this TFT LCD module.

### 9-1. Mounting Precautions

- (1) You must mount a module using specified mounting holes (Details refer to the drawings).
- (2) You should consider the mounting structure so that uneven force (ex. Twisted stress) is not applied to the module. And the case on which a module is mounted should have sufficient strength so that external force is not transmitted directly to the module.
- (3) Please attach the surface transparent protective plate to the surface in order to protect the polarizer. Transparent protective plate should have sufficient strength in order to resist external force.
- (4) You should adopt radiation structure to satisfy the temperature specification.
- (5) Acetic acid type and chlorine type materials for the cover case are not desirable because the former generates corrosive gas of attacking the polarizer at high temperature and the latter causes circuit break by electro-chemical reaction.
- (6) Do not touch, push or rub the exposed polarizers with glass, tweezers or anything harder than HB pencil lead. And please do not rub with dust clothes with chemical treatment. Do not touch the surface of polarizer for bare hand or greasy cloth.(Some cosmetics are detrimental to the polarizer.)
- (7) When the surface becomes dusty, please wipe gently with absorbent cotton or other soft materials like chamois soaks with petroleum benzene. Normal-hexane is recommended for cleaning the adhesives used to attach front / rear polarizers. Do not use acetone, toluene and alcohol because they cause chemical damage to the polarizer
- (8) Wipe off saliva or water drops as soon as possible. Their long time contact with polarizer causes deformations and color fading.
- (9) Do not open the case because inside circuits do not have sufficient strength.

### 9-2. Operating Precautions

- (1) Response time depends on the temperature.(In lower temperature, it becomes longer.)
- (2) Brightness depends on the temperature. (In lower temperature, it becomes lower.)  
And in lower temperature, response time(required time that brightness is stable after turned on) becomes longer
- (3) Be careful for condensation at sudden temperature change.Condensation makes damage to polarizer or electrical contacted parts. And after fading condensation, smear or spot will occur.
- (4) When fixed patterns are displayed for a long time, remnant image is likely to occur.
- (5) Module has high frequency circuits. Sufficient suppression to the electromagnetic interference shall be done by system manufacturers. Grounding and shielding methods may be important to minimized the interference.
- (6) Please do not give any mechanical and/or acoustical impact to LCM. Otherwise, LCM can't be operated its full characteristics perfectly.
- (7) A screw which is fastened up the steels should be a machine screw.  
(if not, it can causes conductive particles and deal LCM a fatal blow)
- (8) Please do not set LCD on its edge.
- (9) The conductive material and signal cables are kept away from LED driver inductor to prevent abnormal display, sound noise and temperature rising.

## Product Specification

### 9-3. Electrostatic Discharge Control

Since a module is composed of electronic circuits, it is not strong to electrostatic discharge. Make certain that treatment persons are connected to ground through wrist band etc. And don't touch interface pin directly.

### 9-4. Precautions for Strong Light Exposure

Strong light exposure causes degradation of polarizer and color filter.

### 9-5. Storage

When storing modules as spares for a long time, the following precautions are necessary.

- (1) Store them in a dark place. Do not expose the module to sunlight or fluorescent light. Keep the temperature between 5°C and 35°C at normal humidity.
- (2) The polarizer surface should not come in contact with any other object.  
It is recommended that they be stored in the container in which they were shipped.
- (3) Storage condition is guaranteed under packing conditions.
- (4) The phase transition of Liquid Crystal in the condition of the low or high storage temperature will be recovered when the LCD module returns to the normal condition

### 9-6. Handling Precautions for Protection Film

- (1) The protection film is attached to the bezel with a small masking tape.  
When the protection film is peeled off, static electricity is generated between the film and polarizer.  
This should be peeled off slowly and carefully by people who are electrically grounded and with well ion-blown equipment or in such a condition, etc.
- (2) When the module with protection film attached is stored for a long time, sometimes there remains a very small amount of glue still on the bezel after the protection film is peeled off.
- (3) You can remove the glue easily. When the glue remains on the bezel surface or its vestige is recognized, please wipe them off with absorbent cotton waste or other soft material like chamois soaked with normal-hexane.

### 9-7. Appropriate Condition for Public Display

- Generally large-sized LCD modules are designed for consumer applications (TV).

Accordingly, a long-term display like in Public Display (PD) application, can cause uneven display including image sticking. To optimize module's lifetime and function, several operating usages are required.

#### 1. Normal operating condition

- Temperature: 0 ~ 40 °C
  - Operating Ambient Humidity : 10 ~ 90 %
  - Display pattern: dynamic pattern (Real display)
- Note) Long-term static display can cause image sticking.

#### 2. Operating usages under abnormal condition

##### a. Ambient condition

- Well-ventilated place is recommended to set up PD system.

##### b. Power and screen save

- Periodical power-off or screen save is needed after long-term display.

LD840EQD

## Product Specification

3. Operating usages to protect against image sticking due to long-term static display
  - a. Suitable operating time: under 18 hours a day.( $25 \pm 2$  °C)
  - b. Static information display recommended to use with moving image.
    - Cycling display between 5 minutes' information(static) display and 10 seconds' moving image.
  - c. Background and character (image) color change
    - Use different colors for background and character, respectively.
    - Change colors themselves periodically.
  - d. Avoid combination of background and character with large different luminance.
    - 1) Abnormal condition just means conditions except normal condition.
    - 2) Black image or moving image is strongly recommended as a screen save.
4. Lifetime in this spec. is guaranteed only when PD is used according to operating usages.
5. Module should be turned counterclockwise or clockwise based on front view when used in portrait mode

LD840EQD

## Product Specification

## # APPENDIX-I

## ■ Pallet Ass'y

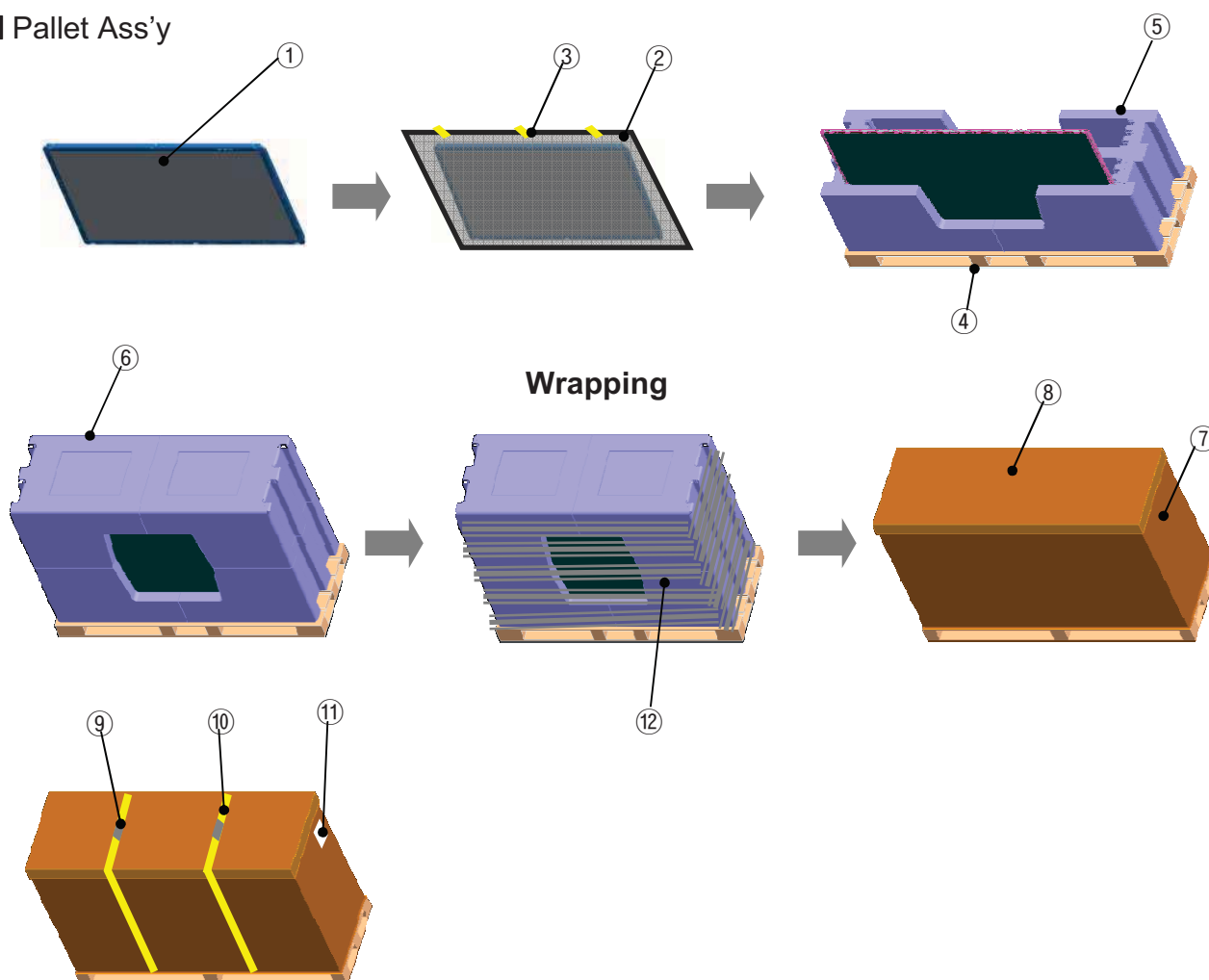

| NO | DESCRIPTION   | MATERIAL               |
|----|---------------|------------------------|
| 1  | LCD Module    | 84" LCD                |
| 2  | BAG           | AL Bag                 |
| 3  | TAPE          | MASKING 20MM X 50M     |
| 4  | PALLET        | Plywood (2280X780X125) |
| 5  | PACKING       | EPS                    |
| 6  | PACKING       | EPS                    |
| 7  | ANGLE PACKING | PAPER                  |
| 8  | ANGLE COVER   | PAPER                  |
| 9  | BAND,CLIP     | STEEL                  |
| 10 | BAND          | PP                     |
| 11 | LABEL         | YUPO PAPER 80G 100X100 |
| 12 | Wrap          | LLDPE                  |

LD840EQD

## Product Specification

## # APPENDIX- II-1

## ■ LCM Label

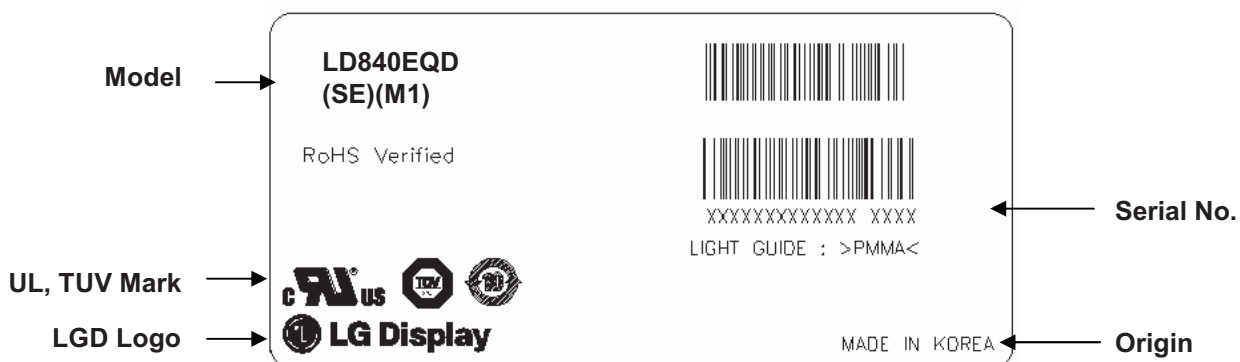

## ■ Production site

- LG Display (Paju) Co., LTD

notes 1.The origin of LCM Label will be changed according to the production site.



LD840EQD

## Product Specification

## # APPENDIX- II-2

## ■ Pallet Label

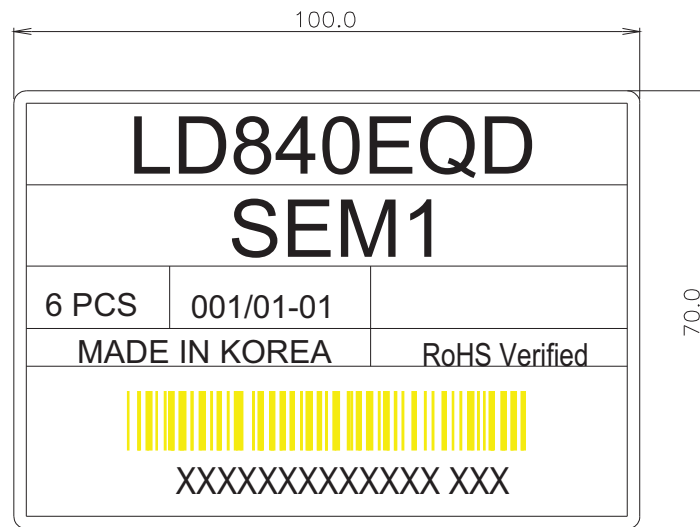

LD840EQD

## Product Specification

## # APPENDIX- III

## ■ Required signal assignment for Flat Link (Thine : THCV216) Transmitter

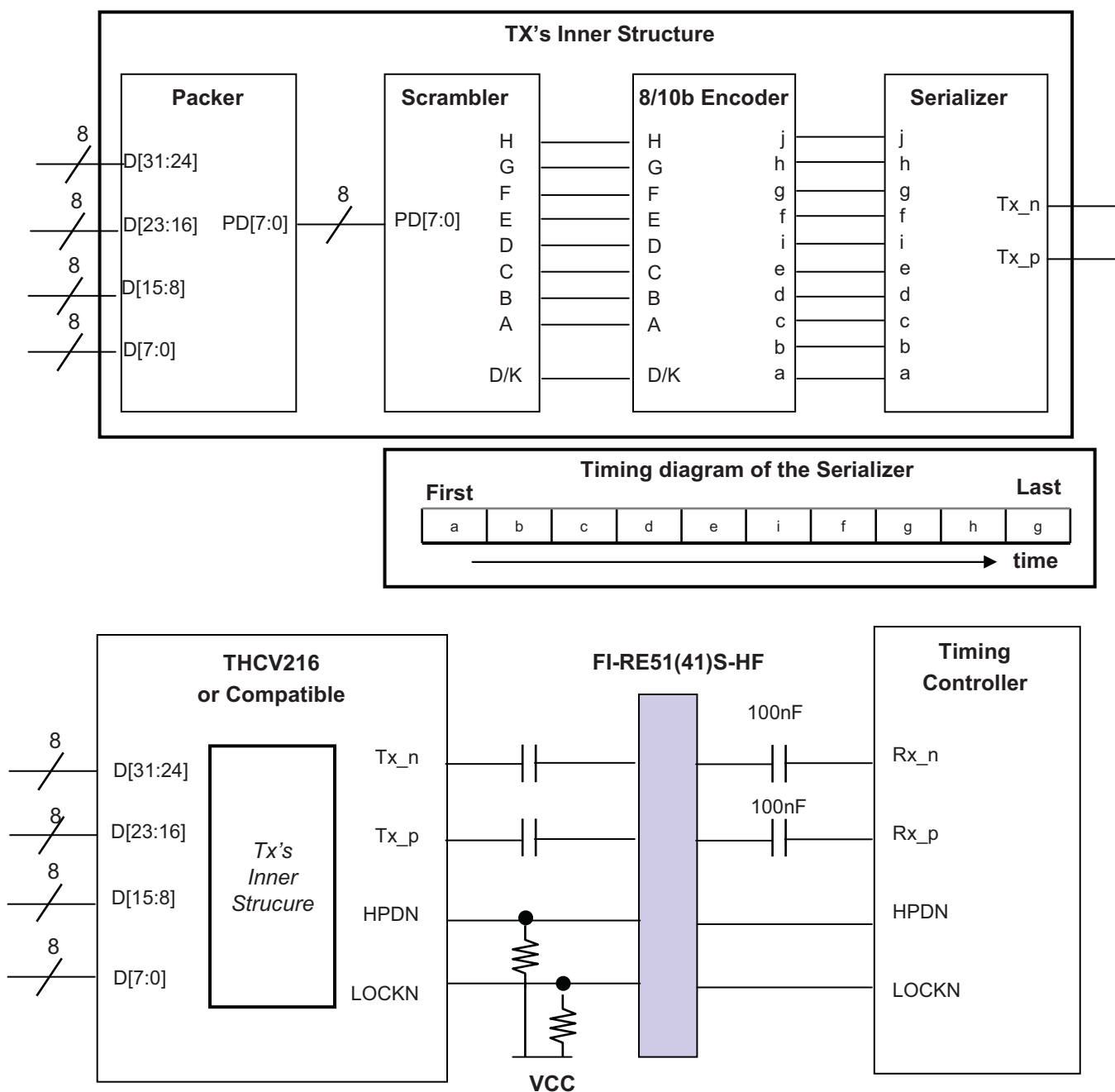

- notes: 1. The LCD module uses a 100 nF capacitor on positive and negative lines of each receiver input.  
 2. Refer to Vx1 Transmitter Data Sheet for detail descriptions. (THCV216 or Compatible)  
 3. About Module connector pin configuration, Please refer to the Page 8~9.

## # APPENDIX- IV-1

## ■ Option Pin Circuit Block Diagram

1) Circuit Block Diagram of Data format Selection pin

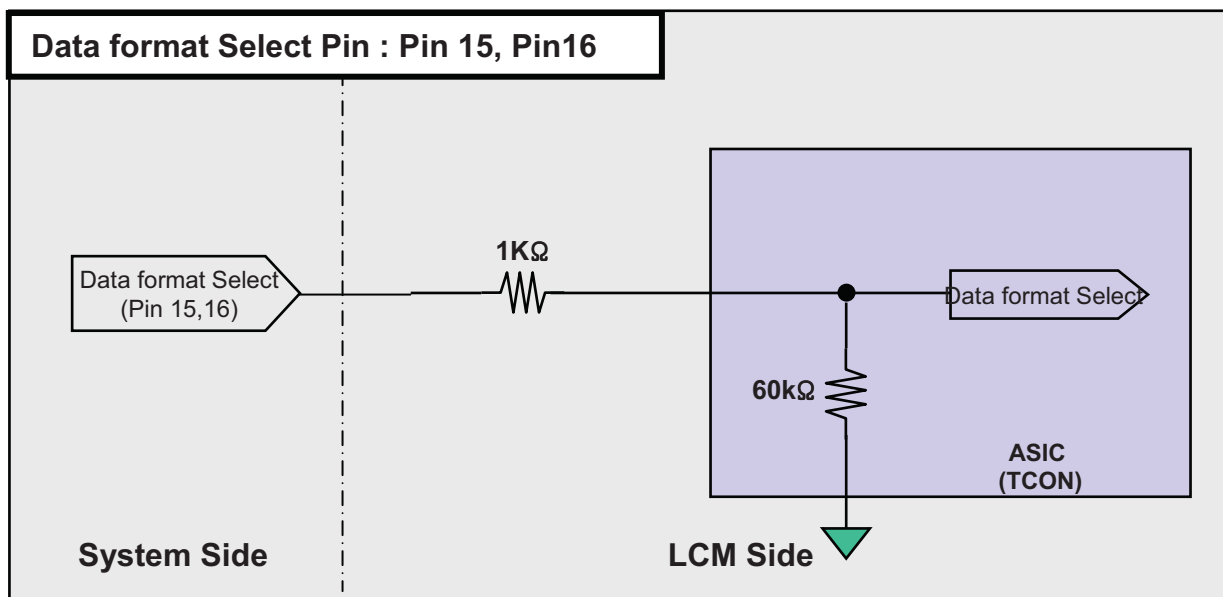

## # APPENDIX- IV-2

## ■ Option Pin Circuit Block Diagram

2) I2C(SDA/SCL) Selection pin

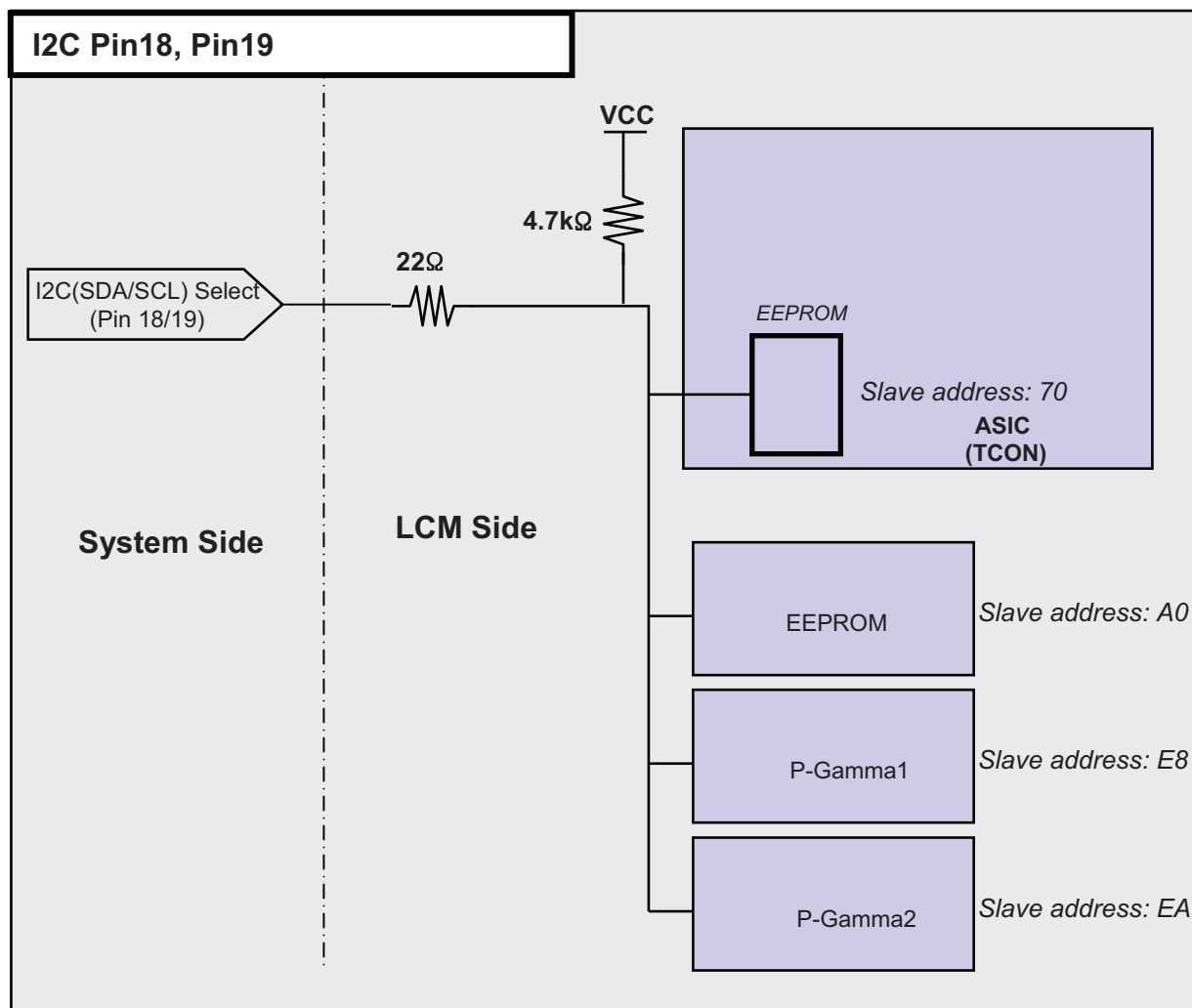

notes: 1. I2C Line of Set SoC avoid using slave address A0,E8,EA because LCD module uses those

## # APPENDIX- IV-3

## ■ Option Pin Circuit Block Diagram

## 3) Circuit Block Diagram of Bit Selection pin

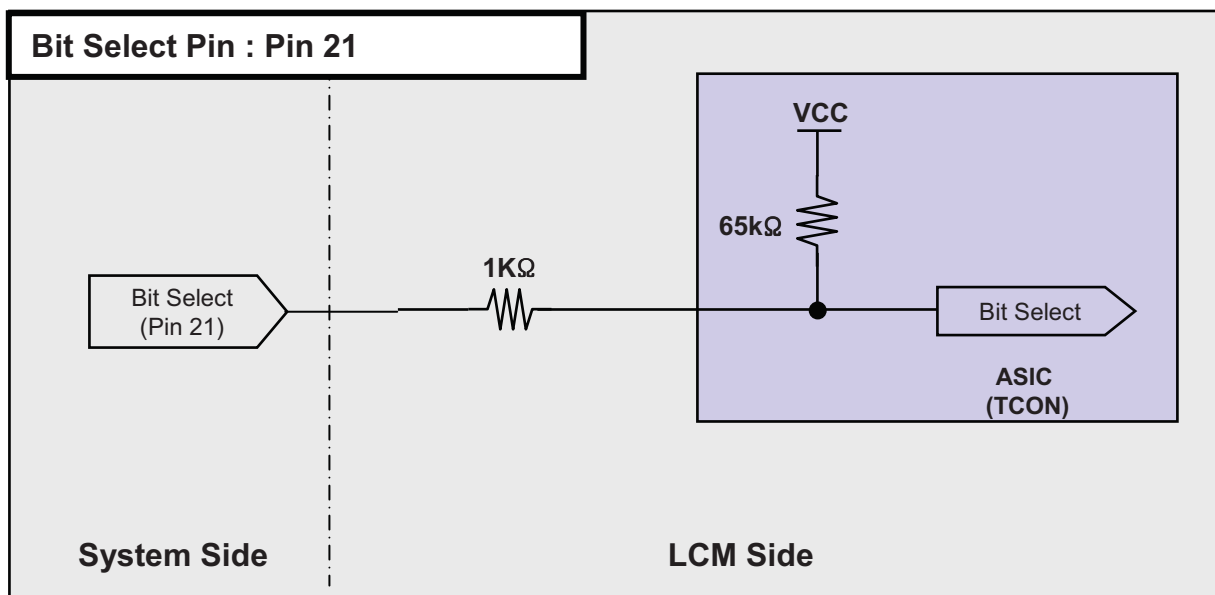

## 4) Circuit Block Diagram of L-Dim Enable Selection pin

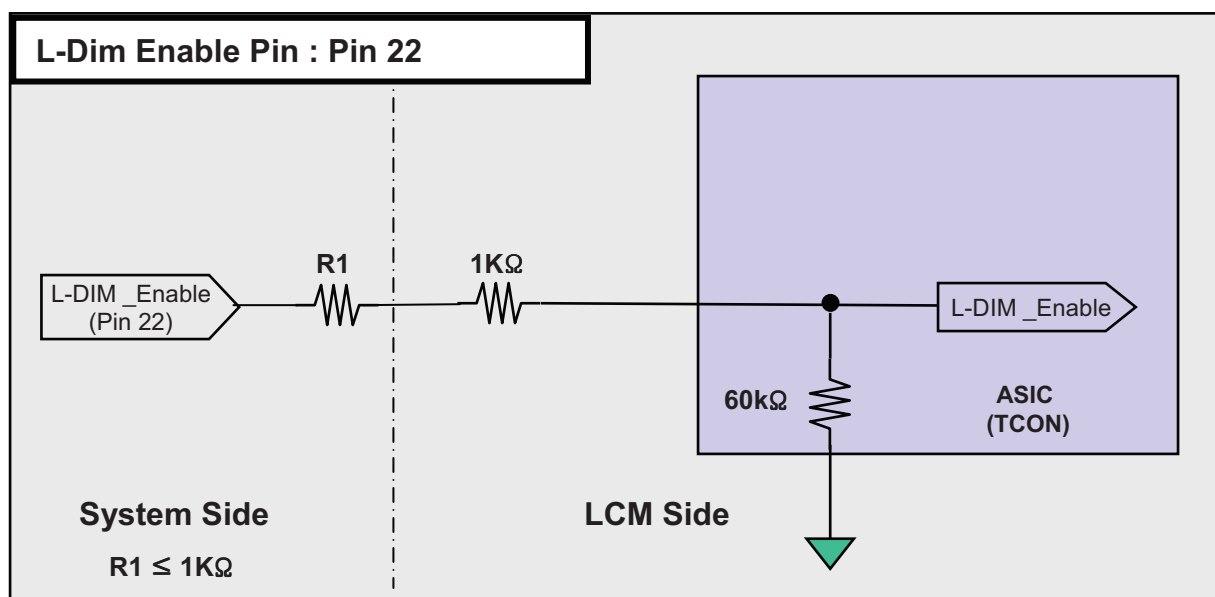

LD840EQD

## Product Specification

## # APPENDIX- IV-4

## ■ Option Pin Circuit Block Diagram

5) Circuit Block Diagram of AGP Selection pin

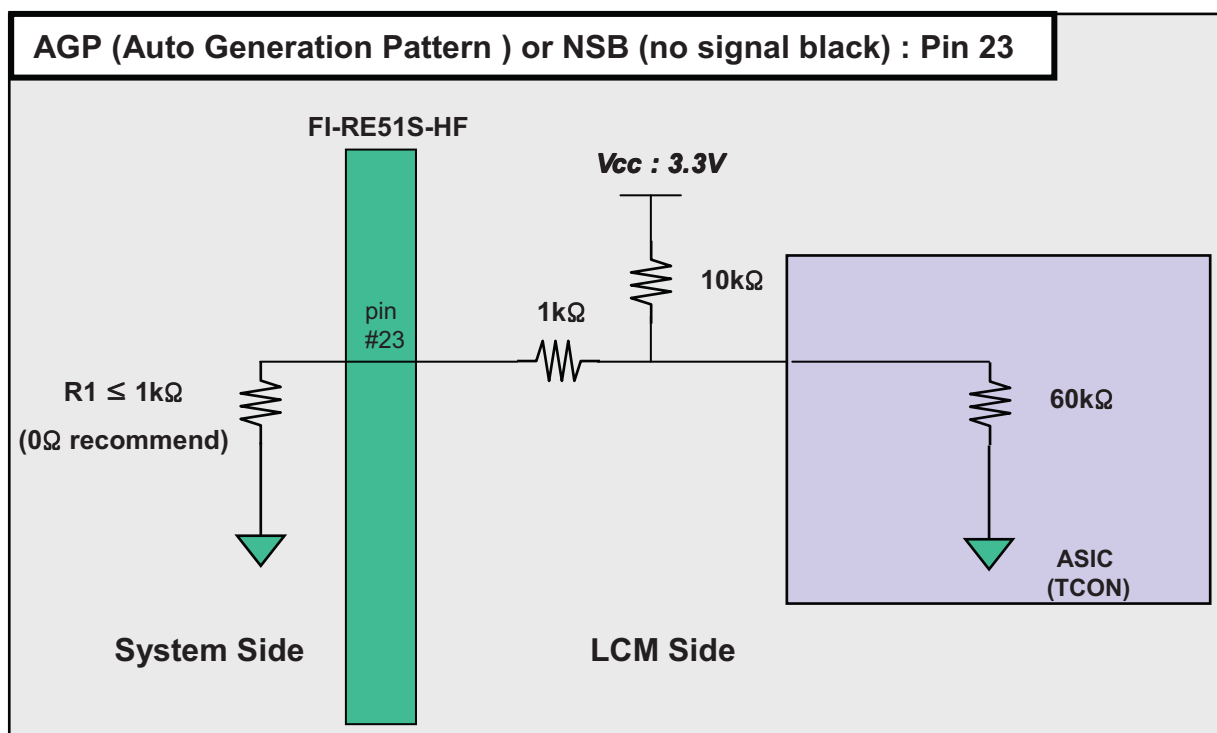

6) Circuit Block Diagram of HTPDN/ LOCKN Selection pin

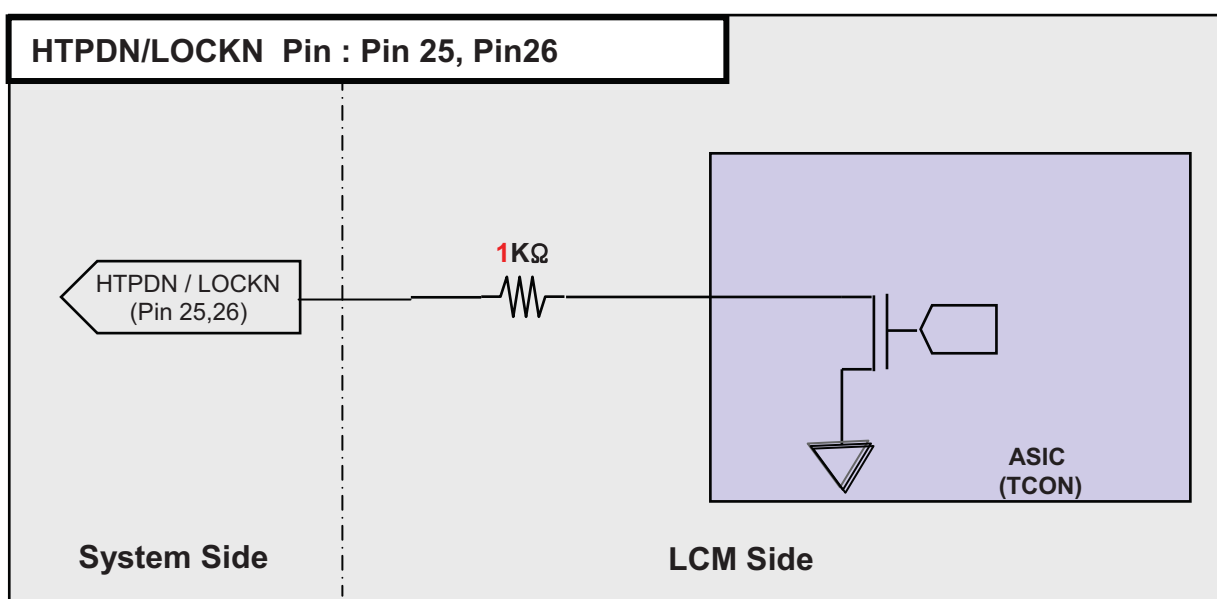

LD840EQD

## Product Specification

## # APPENDIX- V

■ EXT<sub>BR-B</sub> & Local Dimming Design Guide

- 1) When L-Dim Enable is "L", Vertical Sync Signal = System Dimming with 100Hz or 120Hz frequency.
- 2) Local Dimming signals are synchronized with V-Sync Freq. of System in T-Con Board.
- 3) EXT<sub>BR-B</sub> Specification ( VCC = 3.3V ) @ Local Dimming
  - a) High Voltage Range : 2.5 V ~ 3.6 V
  - b) Low Voltage Range : 0.0 V ~ 0.8 V

(4pin)

- #1 : Local Dim Serial Clock
- #2 : Local Dimming Serial Data
- #3 : GND
- #4 : Vertical Sync signal

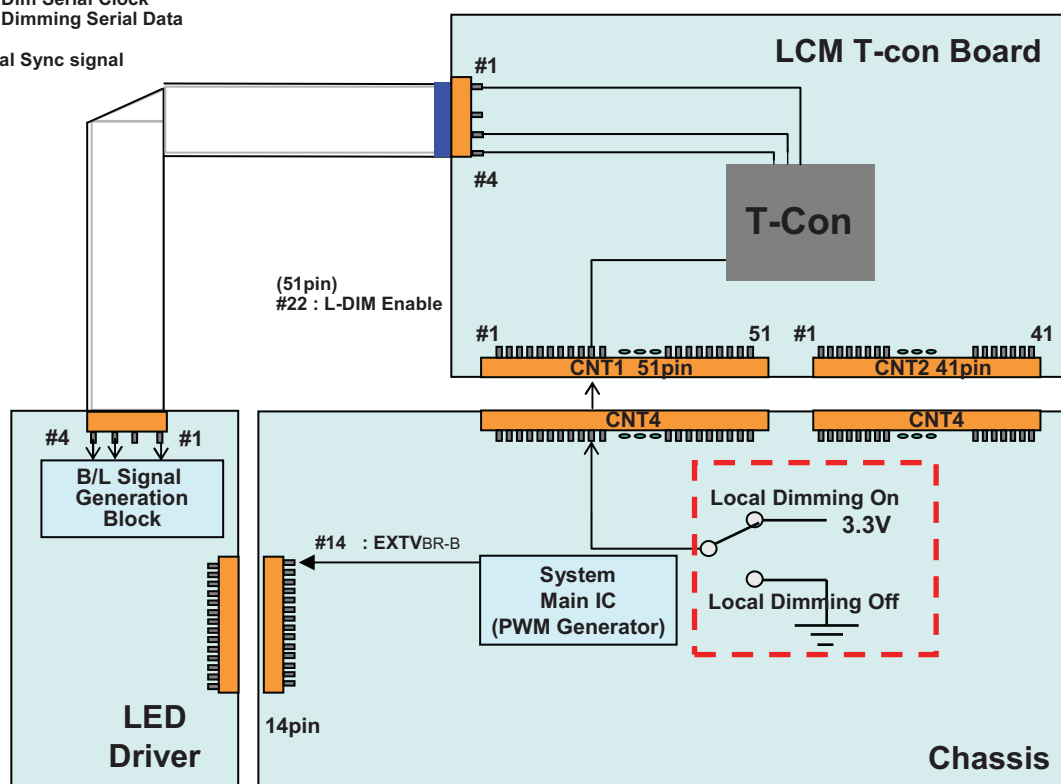

|                               |                                   |
|-------------------------------|-----------------------------------|
| EXT <sub>BR-B</sub> Frequency | 100 Hz for PAL<br>120 Hz for NTSC |
| Rising Time                   | MAX 10.0 $\mu$ s                  |
| Falling Time                  | MAX 10.0 $\mu$ s                  |

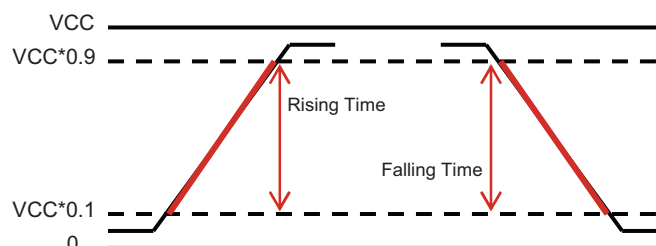

LD840EQD

Product Specification

# APPENDIX- VI

Gray to Gray Response Time Uniformity

This is only the reference data of G to G and uniformity for LD840EQD-SEM1 model.

1. G to G Response Time :

Response time is defined as Figure3 and shall be measured by switching the input signal for "Gray (N) " and "Gray(M)".(32Gray Step at 8bit)

2. G to G Uniformity

The variation of G to G Uniformity ,  $\delta_{G \text{ to } G}$  is defined as :

$$G \text{ to } G \text{ Uniformity} = \frac{\text{Maximum}(G \text{ to } G) - \text{Typical}(G \text{ to } G)}{\text{Typical}(G \text{ to } G)} \leq 1$$

\*Maximum (G to G) means maximum value of measured time (N, M = 0 (Black) ~ 1023(White), 128 gray step).

|          |              |                |                |     |                |                |
|----------|--------------|----------------|----------------|-----|----------------|----------------|
|          | 0Gray        | 127ray         | 255Gray        | ... | 895Gray        | 1023Gray       |
| 0Gray    |              | TrR:0G→127G    | TrR:0G→255G    | ... | TrR:0G→895G    | TrR:0G→1023G   |
| 127Gray  | TrD:127G→0G  |                | TrR:127G→255G  | ... | TrR:127G→895G  | TrR:127G→1023G |
| 255Gray  | TrD:255G→0G  | TrD:255G→127G  |                | ... | TrR:255G→895G  | TrR:255G→1023G |
| ...      | ...          | ...            | ...            | ... | ...            | ...            |
| 895Gray  | TrD:895G→0G  | TrD:895G→127G  | TrD:895G→255G  | ... |                | TrR:895G→1023G |
| 1023Gray | TrD:1023G→0G | TrD:1023G→127G | TrD:1023G→255G | ... | TrD:1023G→895G |                |

3. Sampling Size : 2 pcs

4. Measurement Method : Follow the same rule as optical characteristics measurement.

5. Current Status

Below table is actual data of production on Dec. 03. 2012 ( LGD RV Event Sample)

|     | G to G Response Time [ms] |      | Uniformity |
|-----|---------------------------|------|------------|
|     | Min.                      | Max. |            |
| # 1 | 8.15                      | 18.8 | 0.85       |
| # 2 | 7.57                      | 17.5 | 0.86       |

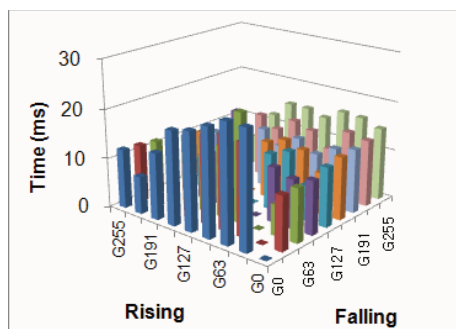

< # 1 >

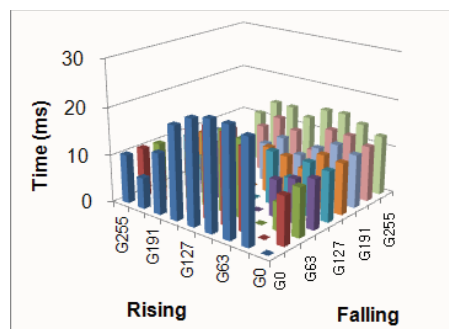

< # 2 >



## Product Specification

## # APPENDIX- VII

## ■ input mode of pixel data

| Mode 1 : Non-Division |          |        |      | Mode 2 : 2 Division |          |        |      |
|-----------------------|----------|--------|------|---------------------|----------|--------|------|
|                       |          |        |      |                     |          |        |      |
| 1st Data              | 2nd Data | Data # |      | 1st Data            | 2nd Data | Data # |      |
| Lane00                | 1        | 17     | 3825 | Lane00              | 1        | 9      | 1913 |
| Lane01                | 2        | 18     | 3826 | Lane01              | 2        | 10     | 1914 |
| Lane02                | 3        | 19     | 3827 | Lane02              | 3        | 11     | 1915 |
| Lane03                | 4        | 20     | 3828 | Lane03              | 4        | 12     | 1916 |
| Lane04                | 5        | 21     | 3829 | Lane04              | 5        | 13     | 1917 |
| Lane05                | 6        | 22     | 3830 | Lane05              | 6        | 14     | 1918 |
| Lane06                | 7        | 23     | 3831 | Lane06              | 7        | 15     | 1919 |
| Lane07                | 8        | 24     | 3832 | Lane07              | 8        | 16     | 1920 |
| 1st Data              | 2nd Data | Data # |      | 1st Data            | 2nd Data | Data # |      |
| Lane08                | 9        | 25     | 3833 | Lane08              | 1921     | 1929   | 3833 |
| Lane09                | 10       | 26     | 3834 | Lane09              | 1922     | 1930   | 3834 |
| Lane10                | 11       | 27     | 3835 | Lane10              | 1923     | 1931   | 3835 |
| Lane11                | 12       | 28     | 3836 | Lane11              | 1924     | 1932   | 3836 |
| Lane12                | 13       | 29     | 3837 | Lane12              | 1925     | 1933   | 3837 |
| Lane13                | 14       | 30     | 3838 | Lane13              | 1926     | 1934   | 3838 |
| Lane14                | 15       | 31     | 3839 | Lane14              | 1927     | 1935   | 3839 |
| Lane15                | 16       | 32     | 3840 | Lane15              | 1928     | 1936   | 3840 |

Product Specification

# APPENDIX- VII

■ input mode of pixel data

### Mode 3 : 4 Division

|        | 1st Data | 2nd Data | Data # |
|--------|----------|----------|--------|
| Lane00 | 1        | 5        | 957    |
| Lane01 | 2        | 6        | 958    |
| Lane02 | 3        | 7        | 959    |
| Lane03 | 4        | 8        | 960    |
| Lane04 | 961      | 965      | 1917   |
| Lane05 | 962      | 966      | 1918   |
| Lane06 | 963      | 967      | 1919   |
| Lane07 | 964      | 968      | 1920   |

|        | 1st Data | 2nd Data | Data # |
|--------|----------|----------|--------|
| Lane08 | 1921     | 1925     | 2877   |
| Lane09 | 1922     | 1926     | 2878   |
| Lane10 | 1923     | 1927     | 2879   |
| Lane11 | 1924     | 1928     | 2880   |
| Lane12 | 2881     | 2885     | 3837   |
| Lane13 | 2882     | 2886     | 3838   |
| Lane14 | 2883     | 2887     | 3839   |
| Lane15 | 2884     | 2888     | 3840   |

### Mode 4 : 8 Division

|        | 1st Data | 2nd Data | Data # |
|--------|----------|----------|--------|
| Lane00 | 1        | 3        | 479    |
| Lane01 | 2        | 4        | 480    |
| Lane02 | 481      | 483      | 959    |
| Lane03 | 482      | 484      | 960    |
| Lane04 | 961      | 963      | 1439   |
| Lane05 | 962      | 964      | 1440   |
| Lane06 | 1441     | 1443     | 1919   |
| Lane07 | 1442     | 1444     | 1920   |

|        | 1st Data | 2nd Data | Data # |
|--------|----------|----------|--------|
| Lane08 | 1921     | 1923     | 2399   |
| Lane09 | 1922     | 1924     | 2400   |
| Lane10 | 2401     | 2403     | 2879   |
| Lane11 | 2402     | 2404     | 2880   |
| Lane12 | 2881     | 2883     | 3359   |
| Lane13 | 2882     | 2884     | 3360   |
| Lane14 | 3361     | 3363     | 3839   |
| Lane15 | 3362     | 3364     | 3840   |