

Ceramic Low Pass Filter

DC to 1450 MHz

NEW!
LFCN-1450



BLUE CELL™

CASE STYLE: FV1206

Maximum Ratings

Operating Temperature	-55°C to 100°C
Storage Temperature	-55°C to 100°C
RF Power Input*	10W max. at 25°C
DC Current Input to Output	0.5A max. at 25°C

*Passband rating, derate linearly to 3.5W at 100°C ambient.

Pin Connections

RF IN	1**
RF OUT	3**
GROUND	2,4

**RF IN & RF OUT can be interchanged

Outline Drawing

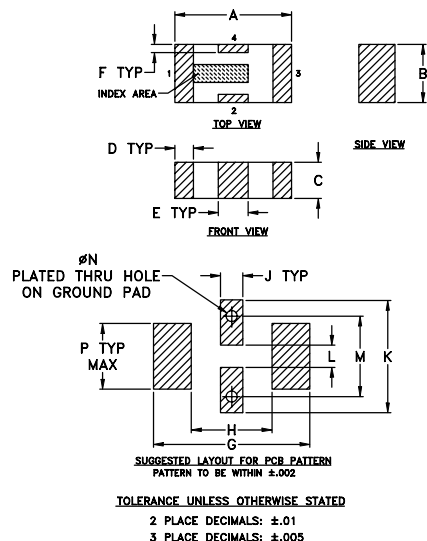

Outline Dimensions (inch)

A	B	C	D	E	F	G	H	J	K	L	M	N	P	wt
.126	.063	.037	.020	.032	.009	.169	.087	.024	.122	.024	.087	.012	.071	grams
3.20	1.60	0.94	0.51	0.81	0.23	4.29	2.21	0.61	3.10	0.61	2.21	0.30	1.80	.020

Demo Board MCL P/N: TB-270
Suggested PCB Layout (PL-137)

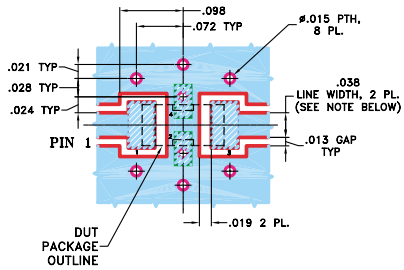

NOTE:
1. TRACE WIDTH IS SHOWN FOR ROGERS RO4350 WITH DIELECTRIC THICKNESS .020" ± .0015". COPPER: 1/2 OZ. EACH SIDE. FOR OTHER MATERIALS TRACE WIDTH MAY NEED TO BE MODIFIED.
2. BOTTOM SIDE OF THE PCB IS CONTINUOUS GROUND PLANE.

- DENOTES PCB COPPER LAYOUT
- DENOTES COPPER LAND PATTERN FREE OF SOLDERMASK

Features

- excellent power handling, 10W
- small size
- 7 sections
- temperature stable
- patent pending

Applications

- harmonic rejection
- VHF/UHF transmitters/receivers
- lab use

Low Pass Filter Electrical Specifications¹ (T_{AMB}=25°C)

MODEL NO.	PASSBAND (MHz) (loss < 1 dB) Max.	f _{co} , MHz Nom. (loss 3 dB) Typ.	STOP BAND (MHz) (loss, dB)			VSWR (:1)		NO. OF SECTIONS
			f 20 Min.	30 Typ.	fr 20 Typ.	Stopband Typ.	Passband Typ.	
LFCN-1450	DC-1450	1825	2025	2050-6600	6700	20	1.2	7

1. For Applications requiring DC voltage to be applied to the Input or output, use LFCN-1450D (DC Resistance to ground is 100 Mohms min.)

typical frequency response

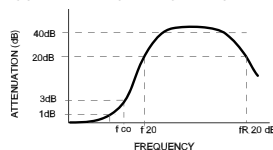

schematic

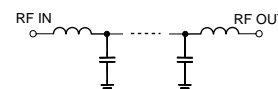

Typical Performance Data at 25°C

Frequency (MHz)	Insertion Loss (dB)	VSWR (:1)
100.00	0.10	1.03
1000.00	0.50	1.12
1400.00	0.86	1.07
1600.00	1.49	1.35
1700.00	2.90	2.22
1800.00	8.10	5.85
2025.00	33.68	18.90
2050.00	36.32	19.98
2500.00	35.12	34.07
2700.00	34.84	37.77
3000.00	37.19	43.44
5000.00	43.89	41.37
6600.00	30.75	21.20
6800.00	16.06	11.85
7000.00	18.67	18.11

