

ABSOLUTE MAXIMUM RATINGS

Item	Symbol	Min.	Max.	Unit
Supply Voltage(Logic)	V <sub>DD</sub> - V <sub>SS</sub>	-0.3	7.0	V
Supply Voltage(LCD)	V <sub>O</sub> - V <sub>SS</sub>	-0.3	7.0	V
Input Voltage	V <sub>I</sub>	-0.3	V <sub>DD</sub> + 0.3	V
Operating Temp.	T <sub>opr</sub>	-20	70	°C
Storage Temp.	T <sub>stg</sub>	-30	80	°C

MECHANICAL DATA

Item	Nominal Dimensions	Unit
Module Size ( W x H x T )	74.0 x 40.0 x 9.5/13.5	mm
Viewing Area ( W x H )	60.5 x 18.5	mm
Dot Pitch ( W x H )	0.44 x 0.49	mm
Dot Size ( W x H )	0.40 x 0.45	mm
Weight (Reflective/LED)	Approx. 28 / 38	g

ELECTRICAL CHARACTERISTICS ( V<sub>DD</sub>=5V±0.25V )

Item	Symbol	Test Condition	Min.	Typ.	Max.	Unit
Input High Voltage	V <sub>IH</sub>	--	0.7V <sub>DD</sub>	--	V <sub>DD</sub>	V
Input Low Voltage	V <sub>IL</sub>	--	- 0.3	--	0.6	V
Output High Voltage	V <sub>OH</sub>	I <sub>OH</sub> = - 0.1mA	0.8V <sub>DD</sub>	--	V <sub>DD</sub>	V
Output Low Voltage	V <sub>OL</sub>	I <sub>OL</sub> = 0.1mA	0	--	0.4	V
Supply Current	I <sub>DD</sub>	V <sub>DD</sub> = 5.0V	--	3.0	5.0	mA
LCD Driving Voltage	V <sub>O</sub> - V <sub>SS</sub>	T <sub>a</sub> =25°C	--	6.5	--	V

PIN CONNECTIONS

Pin	Symbol	Level	Function
1	V <sub>SS</sub>	0V	GND
2	V <sub>DD</sub>	+5V	Supply Voltage for Logic
3	V <sub>O</sub>	--	No connection
4	RS (CS)	H/L	H : Data L : Instruction code (Chip enable for serial mode)
5	R/W (SID)	H/L	H : Read L : Write (Serial data for serial mode)
6	E(SCLK)	H,H >L	Enable (Clock for serial mode )
7	DB0	H/L	Data bus line
8	DB1	H/L	
9	DB2	H/L	
10	DB3	H/L	
11	DB4	H/L	
12	DB5	H/L	
13	DB6	H/L	
14	DB7	H/L	
15	PSB	H/L	H: Parallel mode L: Serial mode
16	/RST	H/L	Reset signal, active "L"
17	LEDA	+5V	Power supply for LED backlight
18	LEDK	0V	

BLOCK DIAGRAM

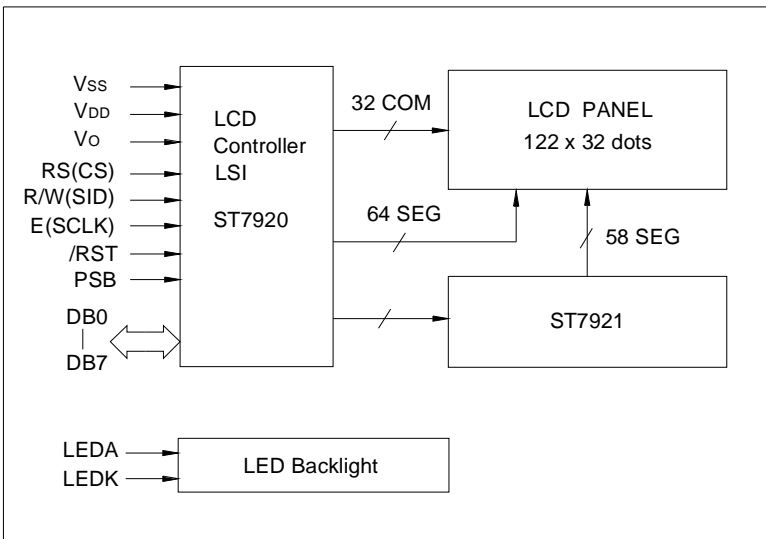

LED BACKLIGHT SPECIFICATIONS (T<sub>a</sub>=25°C)

Item	Symbol	Typ.	Max.	Unit
Forward Voltage	V <sub>f</sub>	4.1	4.3	V
Forward Current	I <sub>f</sub>	120	--	mA
Emission Wave Length	λ <sub>p</sub>	568	--	nm