

ABSOLUTE MAXIMUM RATINGS

Item	Symbol	Min.	Max.	Unit
Supply Voltage (Logic)	V _{DD} - V _{SS}	-0.3	7.0	V
Supply Voltage (LCD)	V _{DD} - V _O	-0.3	30.0	V
Input Voltage	V _I	-0.3	V _{DD} + 0.3	V
Operating Temp.	T _{opr}	-20	70	°C
Storage Temp.	T _{stg}	-30	80	°C

MECHANICAL DATA

Item	Nominal Dimensions	Unit
Module Size (W x H x T)	139.0 x 106.0 x 13.0	mm
Viewing Area (W x H)	103.0 x 79.0	mm
Dot Pitch (W x H)	0.3 x 0.3	mm
Dot Size (W x H)	0.27 x 0.27	mm
Weight	Approx. 190	g

ELECTRICAL CHARACTERISTICS (V_{DD}=5V±0.25V)

Item	Symbol	Test Condition	Min.	Typ.	Max.	Unit
Input High Voltage	V _{IH}	--	0.8V _{DD}	--	V _{DD}	V
Input Low Voltage	V _{IL}	--	0	--	0.2V _{DD}	V
Supply Current	I _{DD}	V _{DD} = 5.0V	--	30.0	50.0	mA
	I _{EE}	V _{EE} = -24.0V	--	5.0	10.0	mA
LCD Driving Voltage	V _{DD} - V _O	T _a =25°C	--	26.0	--	V

PIN CONNECTIONS

Pin	Symbol	Level	Function
1	FLM	H	Scan start-up pulse
2	LP	H>L	Display data latch pulse
3	CP	H>L	Display data shifting pulse
4	NC (M)	--	No connection or M signal for AC driving
5	V _O	--	Operating voltage for LCD
6	V _{DD}	+5V	Power supply for logic
7	V _{SS}	0V	GND
8	V _{EE}	-24V	Input voltage for LCD driving
9	D0	H/L	Data bus line
10	D1	H/L	
11	D2	H/L	
12	D3	H/L	
13	/DISPOFF	H/L	H: display on L: display off
14	NC	--	No connection

BLOCK DIAGRAM

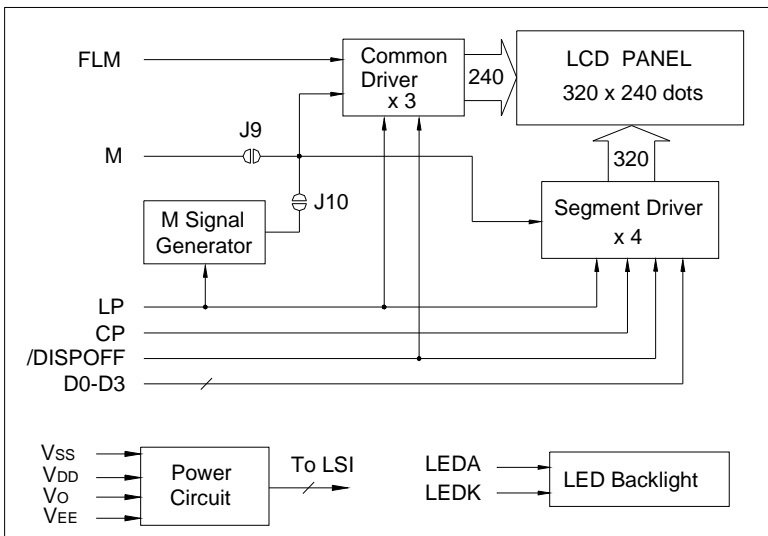

LED BACKLIGHT SPECIFICATIONS (T_a=25°C)

Item	Symbol	Typ.	Max.	Unit
Forward Voltage	V _f	3.8	4.0	V
Forward Current	I _f	135	--	mA
LED Color		White		