

Scanning	LIB.



SPECIFICATION FOR APPROVAL

• **CUSTOMER** : LG Electronics inc.

• **ITEM** : Power Supply Unit.

• **P/NO**

Model Name	Customer	Supplier
LGP32-13PL1	EAY62810301	OPVP-0177

• **DATE** : 2013.08.20

• **Revision** : 3.4

• **Remark** : MP (PCB REV 3.0)

Producing District : CSG (CHINA SUZHOU GENMAO)

생산지 : CSG (중국 소주 겐마오)

★ **Safety Standard Parts [안전규격부품 List]**

Power Cord, Power Plug, X/Y-Capacitor, Power Switch, Fuse, SMPS Trans, Stand-By Trans, Photo coupler, Insulation(절연) Resistor, Discharge(방전) Resistor, Fusing Resistor, FBT.CPT, CPT Socket, DY, D-Coil, Line Filter, PCB Material, Front / Back-cover Material Relay(1-2차간), Varistor, Adapter

★ **EMC Standard Parts [전자규격 부품 List]**

Power Plug, Line Filter, X-Capacitor, Y-Capacitor, SMPS Trans, Tuner, Saw-Filter, Shield Case, Oscillator, Pattern Change

★ **Green [유해물질 확인사항]**

This item must meet the standards of LG Electronics for six major substances as designated by RoHS for control.

(Cd: 10ppm under, Pb/Hg/Cr+6/PBB/PBDE: 100 ppm under)

Lien Chang Electronic Enterprise Co., Ltd.
ADD : No.2, Lane 234, Hsin Shu Rd., Hsin Chuang
Taipei County, Taiwan 242
TEL: (886-2)2203-5100
FAX: (886-2)2202-8472



Documentation For Approval

Model Name	Customer	Supplier
LGP32-13PL1	EAY62810301	OPVP-0177

Written	Checked	Approved
miki	Peter	C.T



Contents

NO.	A table of contents	Page
1	Documentation of Approval	1~2
2	Contents	3
3	Revision History	4
4	CTQ Management	5
5	Specification 1. INTRODUCTION 2. SPECIFICATION 2.1 Input Requirements 2.2 Power Output Characteristics 2.3 Environment Requirement 2.4 Dielectric Strength Voltage and Insulation Resistance 2.5 Burn-in 2.6 Interface 2.7 Product Safety 2.8 Construction 2.9 Function of protection 2.10 Sound Noise Characteristics. 2.11 Connector Specification 2.12 PCB Dimension. 2.13 Apply to Eyelet point. 2.14 Electrical Characteristics 2.15 Mechanical Characteristics	6~16
6	Schematic Diagram	17~18
7	Block Diagram	19~20
8	Parts List	21~25
9	Process Marking	26~27
10	PCB Layout	28~33
11	Safety Parts	34~36
12	Mechanical Drawing	37~40
13	Packing Drawing	41~46
14	Bar-code Label Drawing	47~48
15	Labeling Point	49~50
16	Workmanship Point	51~52
17	Manufacturing Process (Flow-Chart)	53~56
18	* Appendix A1. POWER Check list A2. Warranty letter	57~72



Revision History

Rev No.	Contents	Date of Approval	Checked	Remark
0.1	Apply to PV (PCB REV 0.2) PCB P/No : EAX64905001(2.0) PV 1st Edition.	12.10.19	Peter	
0.2	Apply to PV (PCB REV 0.21) PCB P/No : EAX64905001(2.1) Diode temperature improvement : HS2 (12X11X21)/HS3(15X11X21) → HS2(38*15*17.5) Integration PV 2st Edition	12.11.13	Peter	
0.3	Apply to PV (PCB REV 0.22) PCB P/No : EAX64905001(2.2) 1. Set Assembly Improvement : HS2(38*15*17.5) → HS2(37*10*17.5) PV 2st Edition	12.11.26	Peter	
1.0	Apply to MP (PCB REV 1.0) PCB P/No : EAX64905001(2.4) 1.MP - Add UL Mark	12.12.07	Peter	
1.1	Apply to MP (PCB REV 1.0) PCB P/No : EAX64905001(2.4) 1.CX101 0.33UF changed to 0.47uF 2.CX102 0.33UF changed to 0.22uF 3.R101 1.2M changed to 1M	13.01.09	Peter	
1.2	Apply to MP (PCB REV 1.0) PCB P/No : EAX64905001(2.4) FEELUX TRAN`S 13S-LPM01 ,13S-DD06 Field smell 不良, 刪除 Trans tape maker	13.02.08	Peter	
1.3	Apply to MP (PCB REV 1.0) PCB P/No : EAX64905001(2.4) D203 Lead length management (Max. 2.0mm)	13.04.15	Peter	
2.0	Apply to MP (PCB REV 2.0) PCB P/No : EAX64905001(2.6) 1. PCB is modified (It will be applied from 5/15) 2. AC Socket is modified	13.04.17	Peter	



Revision History

Rev No.	Contents	Date of Approval	Checked	Remark
3.0	Apply to MP (PCB REV 3.0) PCB P/No : EAX64905001(2.7) 1.change J19 -> Axial 1K (PCB REV 3.0 Change 6/1)	13.05.03	Peter	
3.1	Apply to MP (PCB REV 3.0) PCB P/No : EAX64905001(2.7) 1. no use vendor delete, and remain actual vendor	13.05.14	Peter	
3.2	Apply to MP (PCB REV 3.0) PCB P/No : EAX64905001(2.7) 1.Add WANSHENG CERAMIC CAP 4M	13.05.21	Peter	
3.3	Apply to MP (PCB REV 3.0) PCB P/No : EAX64905001(2.7) 1.ION FLUX Model : ILF714 →ILF710 2.R801 1K Ω → 0Ω (8/13)	13.07.14	Peter	
3.4	Apply to MP (PCB REV 3.0) PCB P/No : EAX64905001(2.7) <DONGIL> AC Socket modify : add cover , DAC-18C3M1→DAC-18C3M1c (It will be applied from 9/23)	13.08.20	Peter	



CTQ Management

No.	Contents	Page
1	2.1.1 Power Factor	8
2	2.2 .1 Stand By Power Consumption	8



Specification



1. INTRODUCTION

1.1 Scope

This approval is the description related to every electrical and structural specifications and reliability For Power Supply Unit used on 32 inch LGE LED TV.

1.2 Customers product related items

Product : Power Supply Unit
Part code : EAY62810301

1.3 Product name

Product name : LGP32-13PL1
Revision code : 3.4

2. SPECIFICATION

2.1 Input Requirements

Nominal Input Voltage	AC 100V to AC 240V
Input Voltage Variation	AC 90V to AC 264V
Input Current	Under 1.5Arms . (at 100Vac & Nominal Load) Under 0.7Arms . (at 240Vac & Nominal Load)
Nominal Frequency	50 / 60 Hz
Frequency Variation Range	47 Hz to 63 Hz
Phase	Single
Leakage Current	0.35mA_peak. (100Vac ~ 240Vac)
Surge Immunity	± 4kV / 1000ns / 0° to 360°
Hold-up Time	More than 20ms at 100Vac and maximum output load ※When it doesn't meet 20ms hold up time, 1. PSU restarts. 2. No hardware failure.(All components)
Lightning Surge	2kA Normal, Common Mode
Inrush Current	80A zero-peak max at cold start and any specified line, load, temperature conditions.

2.1.1 Power Factor

over than 0.4 at 90 – 264Vac & max load condition



2.2 Power Output Characteristics

Output	Voltage Variable range [V]	Rated Current (Min, Max) [Amean]	Voltage Regulation [V]	Ripple Voltage [mVp_p]
3.5V (STBY)	3.325V ~ 3.675V	0.3W Under (15mA)	-	-
		1.4A (0.2~1.4A) (ON condition)	± 5%	250 mVp_p
12V	11.4V ~ 12.6V	1.2A (0.2~1.2A)	± 5%	350 mVp_p
24V	21.6V ~ 27.0V	0.6A (0.1~0.6A)	± 10%	500 mVp_p
LED B+	65.6V~86.9V	0.4A(0.380~0.420A)	± 5%	-

* On Condition : In a moment of Power_ON Signal activated, the current of 3.5V output should be limited within 40mA(Max) at LCD TV condition for stability.

Do not turn "Power_ON" Signal on at the load condition of 3.5V output, more than 40mA.

* Total regulation for each output circuit includes the results of input voltage variation, load variation, warm-up drift and temperature change.

* Maximum input Wattage Rating : Under 75W

* The following instruments shall be used for measuring ripple noise.

1. Probe having impedance ratio of 1:1.
2. Oscilloscope having frequency characteristic of 100MHz or more.

Test Point : power output each pin

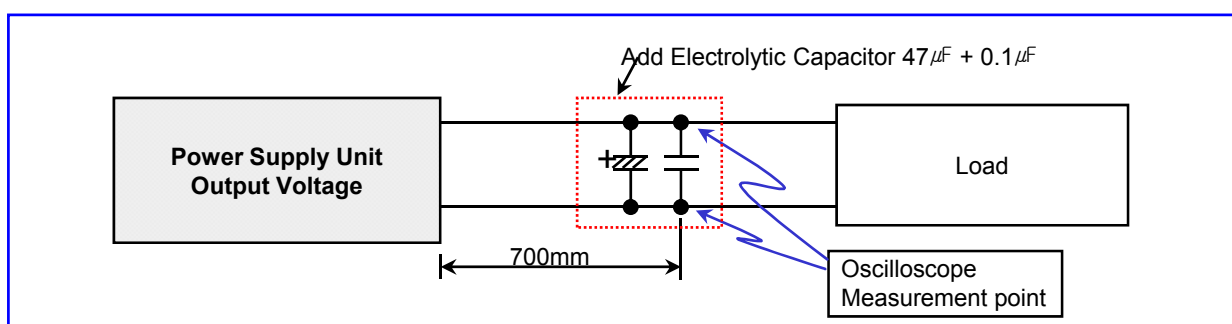

※ Ripple and noise are measured at the end of output cable which are added a 0.1uF ceramic capacitor and 47uF electrolytic capacitor. (connected parallel)

2.2.1 Stand By Power Consumption

Output Voltage	3.5V (STBY)	12V	24V
Load [A]	0.015	Don't Care (Power-Off)	
Wattage [W]	Less than 0.3W Under (230Vac / 50Hz)		



2.3 Environment Requirement

Operating Temperature Range	-10°C to 40°C (60°C :No Hardware Failure, TV SET Condition)
Operating Humidity Range	30 to 85 %
Storage Temperature Range	-25 to 85 deg.
Storage humidity Range	5 to 90 %
Power board Storage Condition	Temperature 40°C, Humidity 90%
MTBF (Mean Time Between Failure)	50,000 hour
Cooling Condition	Natural Air
Shock	98 m/s ² Shock test consists of pivoting the power supply, from one edge of it's bottom side, on a flat surface (such as wood having thickness of 10mm or more) and allowing the opposite edge to fall from a height of 50mm to this surface. The test is performed three times on each edge of the bottom side of the power supply

2.4 Dielectric Strength Voltage and Insulation Resistance



Dielectric Strength Voltage	AC 1.5KV or DC 2,121V 1 Min 10 mA (Test SPEC) AC 1.8KV 1 Sec 10 mA (PSU Mass Production) Between Primary and All Secondary Circuits.
Insulation Resistance	Insulation resistance shall be more than 8M ohm (at DC 500V) Between Primary Live, Neutral line and Secondary.

- * Above tests are performed at room temperature in non-condensing atmospheric conditions
- * Frame grounds are connected to secondary circuits.

2.5 Burn-in

More than 2 hours at 45°C (±5°C), Normal input voltage.
AC on/off must be test 1 time after burn-in.
80% Load of specification.



2.6 Interface

Appellation	Explanation	Signal Direction	Action
POWER ON	Vcc Circuit ON/OFF	Input	High : Vcc ON Low : Vcc OFF

2.7 Product Safety



Safety Standards to be applied	Design to meet the requirements as follows UL60950, IEC60950, IEC60065 and 60950
EMI/RFI Standards to be applied	Design to meet the requirements as follows FCC and EN55020, EN55013 Class B with 4dB minimum margin.

2.8 Construction

Weight	Less than 400g
Unit Size (typ.)	159(W) X 121(D) X 26.1(H)

2.9 Function of protection

Protection	Output Circuit	Trip point		Notes
		Min	Max	
Over Current	STBY 3.5V	3.0A	11.5A	Auto Re-start
	12V	2.0A	7.0A	Auto Re-start
	24V	0.8A	4.5A	Auto Re-start
Short Circuit	STBY 3.5V	-	-	Auto Re-start
	12V	-	-	Auto Re-start
	24V	-	-	Auto Re-start

- * This Power Supply has above-mentioned protections.
- * Short circuit protection between different output terminals is not considered.
- * Trip point for over voltage indicates the operating point when the output voltage slowly increases.
- * The conditions of Over Current measurement
Multi output(3.5V,12V,24V) is nominal load state except an over current measurement.



2.10 Sound Noise Characteristics.

PSU Noise Specification

22.5 dB(a) / 20.u Pa 2.0E-5 Pa

(1/1 octave, A-weighting, to 1khz ~ 16khz Total overall

Measure Location : Anechoic Room

Measure Condition : At a distance of 60cm mic

Full white pattern, at AC 110V/220V

The max specification

(measure 3 points, at PSU center and left & right on the side)

PSU NOISE MEASURE POINT

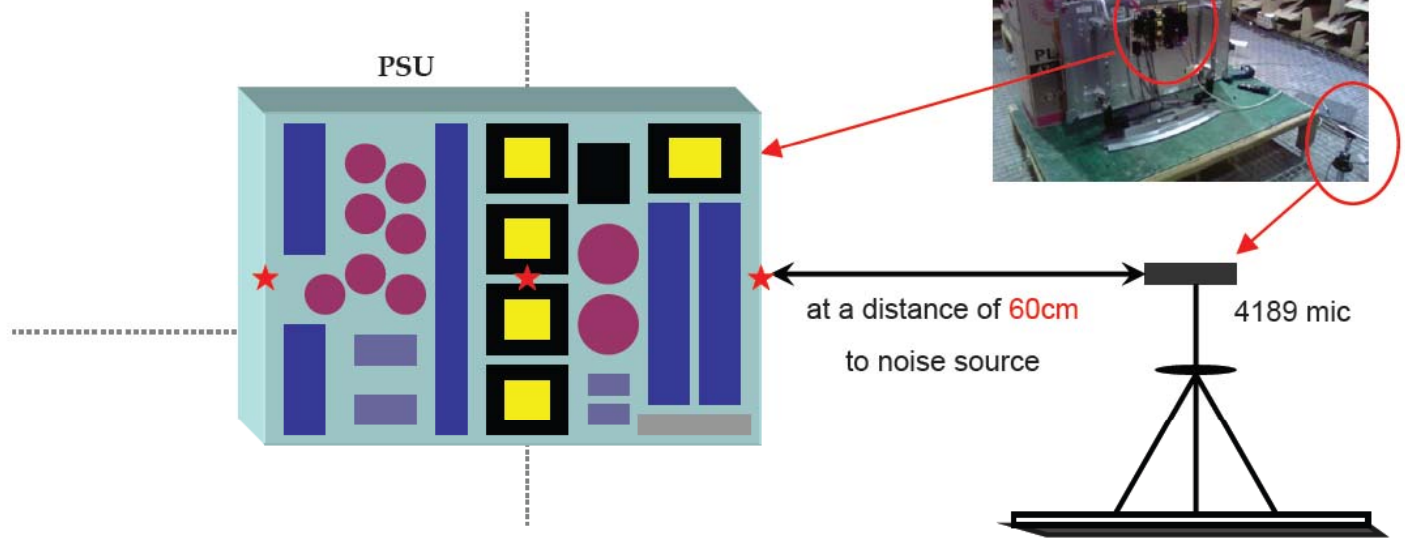



2.11 Connector Specification

2.11.1 Connectors Usage

SK100 DONGIL TECH (DAC-18C3M1 c)	
Pin No.	Assignment
1	LIVE
2	GND
3	NEUTRAL

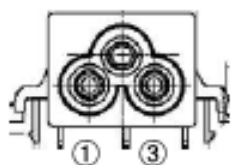

P801 YEONHO (SMAW200A-H07AA2)	
Pin No.	Assignment
1	LED-
2	Remove
3	N.C
4	Remove
5	N.C
6	Remove
7	LED+

P201 YEONHO (SMAW200-H18S2)			
Pin No.	Assignment	Pin No.	Assignment
1	Power on	2	DRV-ON
3	3.5V	4	PDIM #1
5	3.5V	6	N.C
7	GND	8	GND
9	24V	10	24V
11	GND	12	GND
13	12V	14	12V
15	12V	16	N.C
17	GND	18	GND



2.12 PCB Dimension.

- 1) Power board PCB : 159mm × 121mm × 1.6(T)mm
- 2) Component height : Max 22.0mm (Except LF101 : Max 23.0mm)
- 3) Lead Cutting : Max 2.5mm
- 4) PCB Material : FR-1 KB,DS,L,R-8700 CTI-600

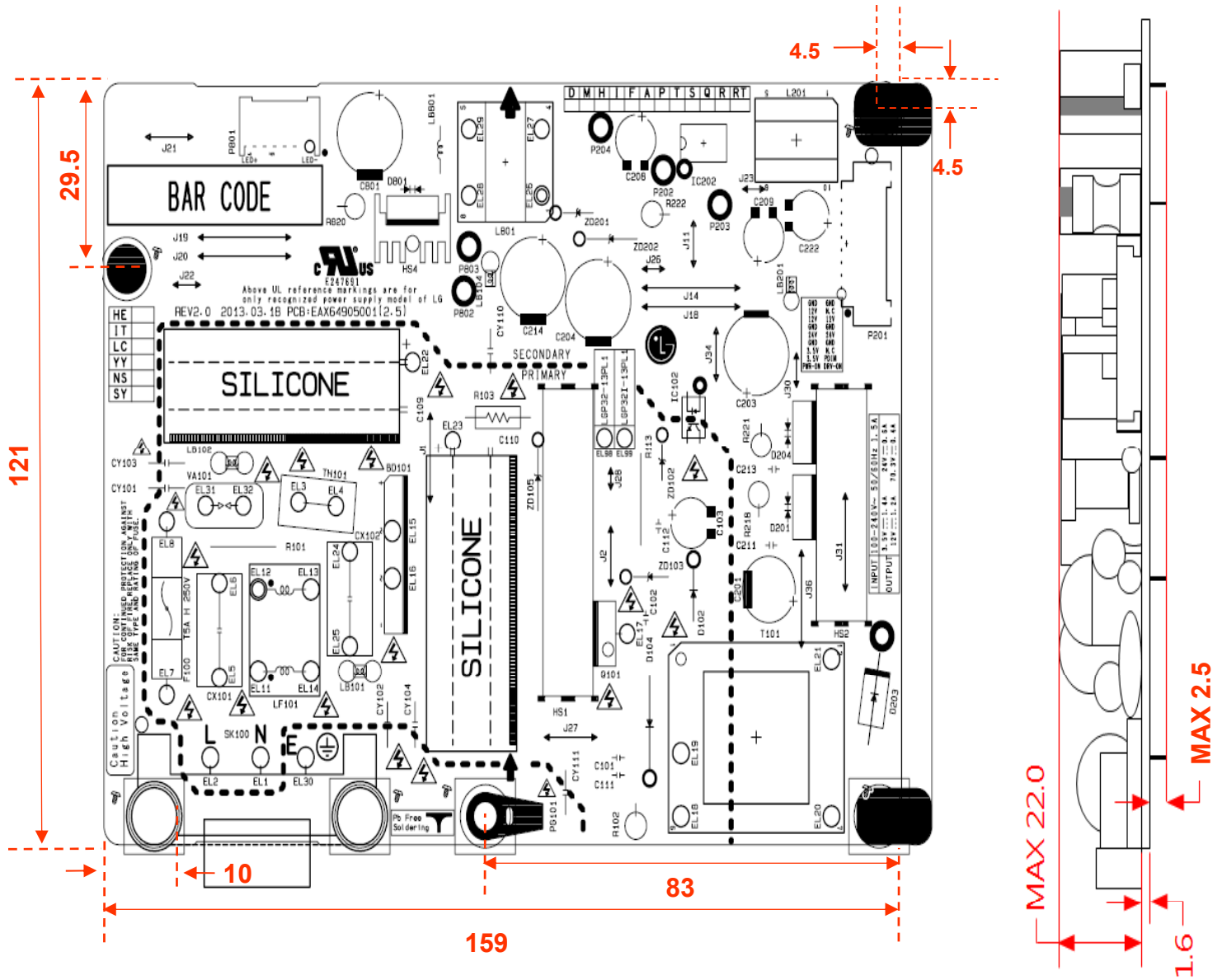



2.13 Apply to the Eyelet point.

Apply to the Eyelet point 2.0Φ : EL1,EL2,EL11,EL12,EL13,EL14,EL15,EL16,EL18,EL19,EL20,EL21,EL30(13EA)

Apply to the small Eyelet point 1.6Φ : EL3,EL4,EL5,EL6 EL7,EL8,EL17,EL22,EL23,EL24,EL25,EL26,EL27,EL28,EL29, EL31,EL32,EL98 (18EA)

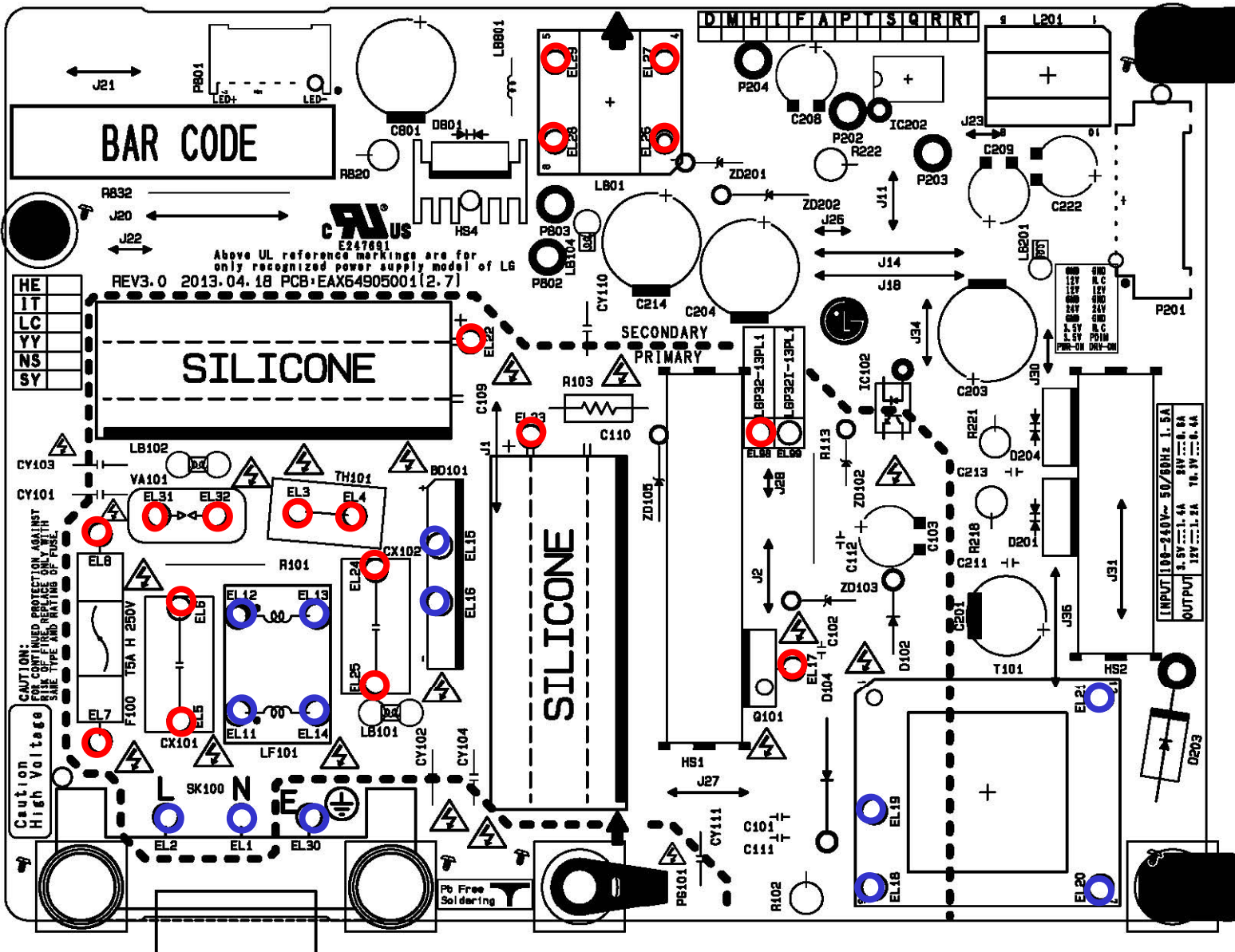



2.14 Electrical Characteristics

No.	Test Item	Test method																		
1	Intermittent Operation stability Test	The switching regulator shall ON/OFF for 20,000 time at an Interval of 10 sec at maximum load, after that electrical Characteristics shall be satisfied.																		
2	Low temperature operation	The switching regulator is left at the operating guarantee Minimum temperature for 2 hours without applying electricity. After that power shall be turned on, and then the electrical Characteristics shall be satisfied.																		
3	Low temperature Storage test Leave At low temperature	The switching regulator is left at minimum storage Temperature for 96 hours or more. Then the switching regulator is left at a room temperature and humidity for 1 hour or more, after that electrical characteristics shall be satisfied.																		
4	Heat cycle storage test	<p>The switching regulator is 10 consecutive temperature cycle that shown below is performed and then leave them at room temperature and humidity for 1 hour or more. After that, electrical characteristics shall be satisfied.</p> <table border="1"> <thead> <tr> <th>Time</th> <th>Temperature</th> </tr> </thead> <tbody> <tr> <td>30 minutes</td> <td>25°C</td> </tr> <tr> <td>30 minutes</td> <td>25°C -> -20°C</td> </tr> <tr> <td>60 minutes</td> <td>Minimum storage temperature (-20°C)</td> </tr> <tr> <td>30 minutes</td> <td>-20°C -> 25°C</td> </tr> <tr> <td>30 minutes</td> <td>25°C</td> </tr> <tr> <td>30 minutes</td> <td>25°C -> 70°C</td> </tr> <tr> <td>60 minutes</td> <td>Maximum storage temperature (70°C)</td> </tr> <tr> <td>30 minutes</td> <td>70°C -> 25°C</td> </tr> </tbody> </table>	Time	Temperature	30 minutes	25°C	30 minutes	25°C -> -20°C	60 minutes	Minimum storage temperature (-20°C)	30 minutes	-20°C -> 25°C	30 minutes	25°C	30 minutes	25°C -> 70°C	60 minutes	Maximum storage temperature (70°C)	30 minutes	70°C -> 25°C
Time	Temperature																			
30 minutes	25°C																			
30 minutes	25°C -> -20°C																			
60 minutes	Minimum storage temperature (-20°C)																			
30 minutes	-20°C -> 25°C																			
30 minutes	25°C																			
30 minutes	25°C -> 70°C																			
60 minutes	Maximum storage temperature (70°C)																			
30 minutes	70°C -> 25°C																			
5	Heat shock test	<p>Heat shock test performed under following conditions without applying electricity and then leave them at room temperature and humidity for 1 hour or more. After that, electrical characteristics shall be satisfied.</p> <p>Condition : -45°C (30minutes), 120°C (30minutes), Switching time : Less than 5 minutes, 200 cycles.</p>																		



2.15 Mechanical Characteristics

No.	Test Item	Test method
1	Appearance	<p>There shall be no contaminant or dirt on the switching regulator which has adverse effect on electrical characteristics.</p> <p>There shall be no excessive unevenness or scratches on the plated or painted surface.</p>
2	Vibration	<p>While applying electricity :</p> <p>Vibration frequency : 5 ~ 100Hz</p> <p>Acceleration : 4.9 m/s²</p> <p>Vibration in X,Y,Z direction for 30 minutes</p> <p>While applying electricity :</p> <p>Vibration frequency : 5 ~ 100Hz</p> <p>Acceleration : 14.7 m/s²</p> <p>Vibration in X,Y,Z direction for 30 minutes</p> <p>After that electrical characteristics shall be satisfied.</p> <p>There shall be no damage to appearance and construction.</p>
3	Shock	<p>Shock : 98 m/s²</p> <p>On the oak more than 10mm thickness with the flat face, raise the one side for 50mm, and it carries out each side free fall for three sides.</p> <p>There shall be no damage to appearance and construction.</p>



Schematic Diagram

MODEL	C109,C110
LGP32-13PL1	68uF/450V KMF
LGP32I-13PL1	100uF/500V NZE

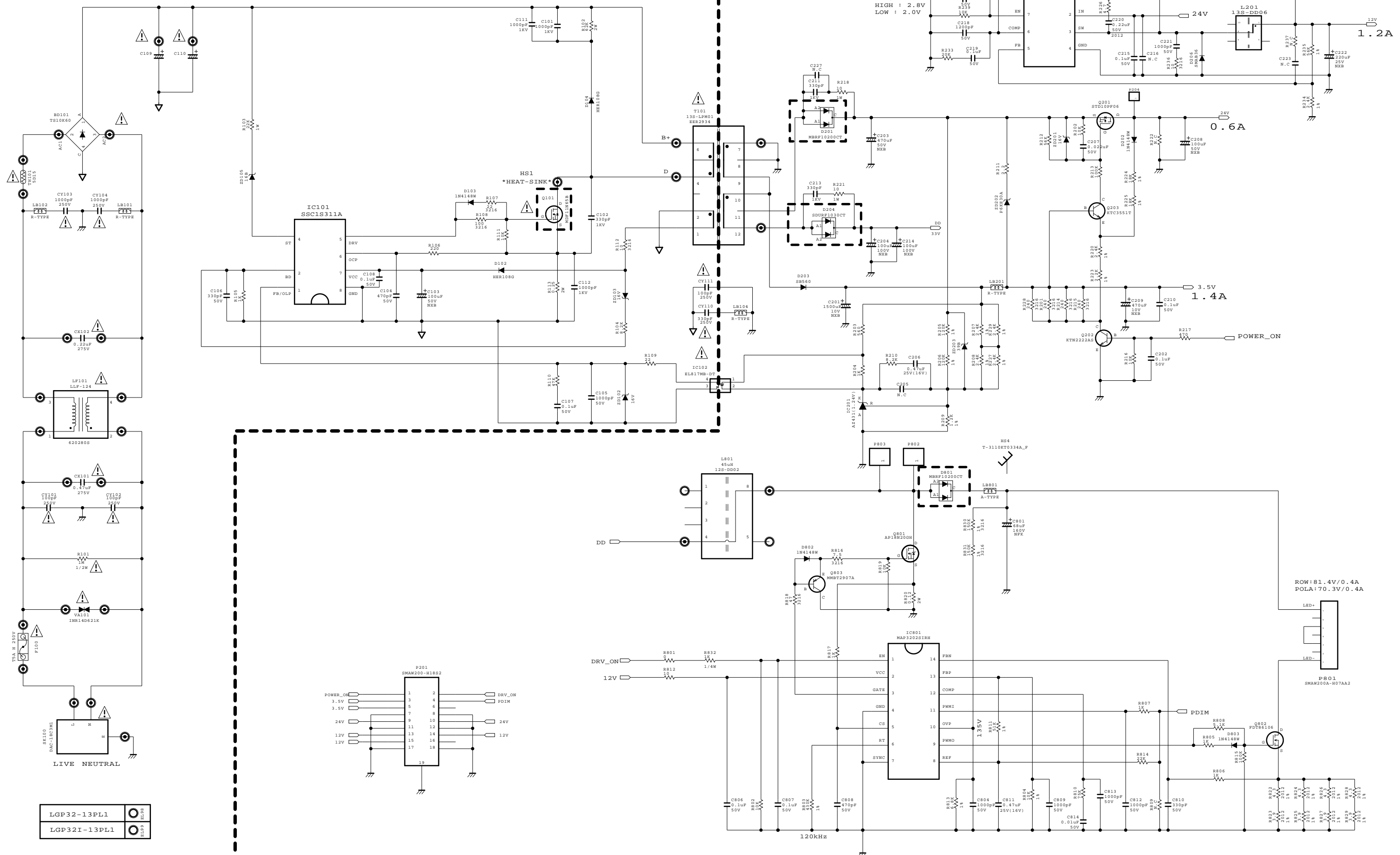

LGP32-13PL1	EL298
LGP32I-13PL1	EL298

SECRET
LGElectronics



MODEL	LGP32-13PL1	DATE	'13.04.18
BLOCK	QRC/LED	SHEET	1 / 1

THE SYMBOL MARK OF THIS SCHEMATIC DIAGRAM INCORPORATES SPECIAL FEATURES IMPORTANT FOR PROTECTION FROM X-RADIATION. FILRE AND ELECTRICAL SHOCK HAZARDS, WHEN SERVICING IF IS ESSENTIAL THAT ONLY MANUFACTURES SPECIED PARTS BE USED FOR THE CRITICAL COMPONENTS IN THE SYMBOL MARK OF THE SCHEMATIC.



Block Diagram



LGP32-13PL1 LCD TV Power specification

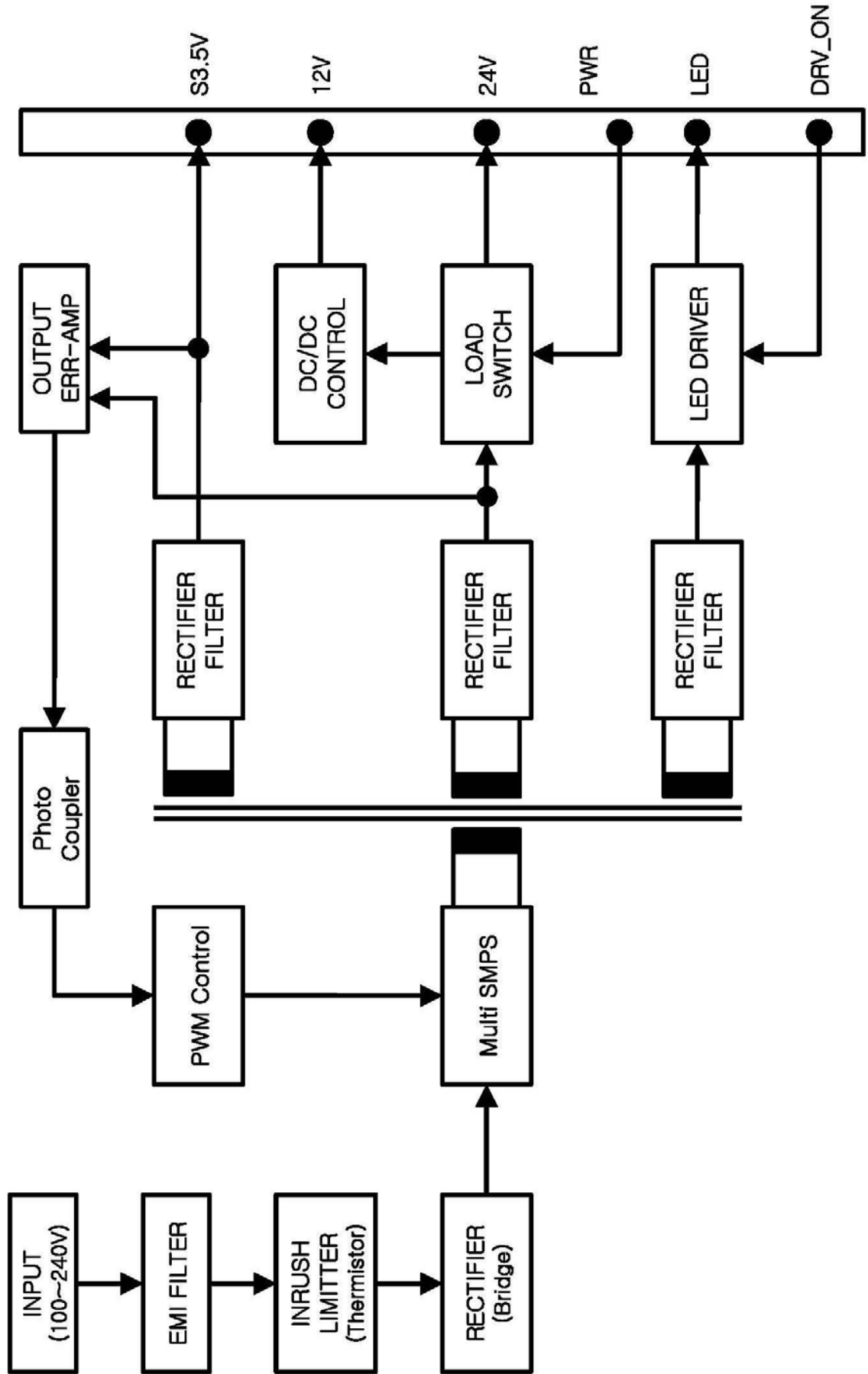



Parts List



LGP32-13PL1 LCD TV Power specification

NO.	L/V	Q'ty	UNIT	LOCATION	SPECIFICATION	DESCRIPTION	MAKER
	MI				FET ASS'Y	HEAT SINK ASS'Y	
1	MI	1	EA	HS1	HS1(49*10*17.5)	HEAT SINK	MINGXUE HUAPENG YAOFENG
2	MI	1	EA	Q101	MDF11N65B 650V 12A TO-220F TK8A65D 650V 8A TO-220F	FET	MAGNACHIP TOSHIBA
3	MI	1	EA	FOR Q101	M/S S/W + Φ3.0 7L SILVER PLATE HEAD M/S S/W + Φ3.0 8L PAN HEAD BHM Screw , M3.0 * 6.0L, with Clamfix, Cr3+WH Plating	SCREW	RUI YOU ROEN
4	MI	0.01	GR	FOR Q101	KD-3 H-SC-7	SILICON GREASE	SANCHEN XUNWEI
	MI				DIODE ASS'Y	HEAT SINK ASS'Y	
5	MI	1	EA	HS2	HS2(37*10*17.5)	HEAT SINK	MINGXUE HUAPENG YAOFENG
6	MI	1	EA	D201	MBRF10200CT 200V 10A ITO-220AB MBRF10U200CT 200V 10A TO-220IS MBRF10200CT 200V 10A ITO-220AB	DIODE	SENSITRON KEC TSC
7	MI	1	EA	D204	SDURF1030CT 300V 10A ITO-220AB U10A3CIC 300V 10A TO-220IS SFF1005G 300V 10A ITO-220AB	DIODE	SENSITRON KEC TSC
8	MI	2	EA	FOR D201,D204	M/S S/W + Φ3.0 7L SILVER PLATE HEAD M/S S/W + Φ3.0 8L PAN HEAD BHM Screw , M3.0 * 6.0L, with Clamfix, Cr3+WH Plating	SCREW	RUI YOU ROEN
9	MI	0.02	GR	FOR D201,D204	KD-3 H-SC-7	SILICON GREASE	SANCHEN XUNWEI
	MI				DIODE ASS'Y	HEAT SINK ASS'Y	
10	MI	1	EA	HS4	HS4(15*11*21)	HEAT SINK	MINGXUE HUAPENG YAOFENG
11	MI	1	EA	D801	MBRF10200CT 200V 10A ITO-220AB MBRF10U200CT 200V 10A TO-220IS MBRF10200CT 200V 10A ITO-220AB	DIODE	SENSITRON KEC TSC
12	MI	1	EA	FOR D801	M/S S/W + Φ3.0 7L SILVER PLATE HEAD M/S S/W + Φ3.0 8L PAN HEAD BHM Screw , M3.0 * 6.0L, with Clamfix, Cr3+WH Plating	SCREW	RUI YOU ROEN
13	MI	0.01	GR	FOR D801	KD-3 H-SC-7	SILICON GREASE	SANCHEN XUNWEI
	MI				LGP32-13PL1 MI COMPONENTS	MI ASSY	
14	MI	1	EA	BD101	TS10K60 600V 10A KBJ1006G 600V 10A D10XB60 600V 10A	DIODE	TSC LITEON DACHANG
15	MI	1	EA	D203	SB560 60V 5A P20 SB560 60V 5A P20	DIODE	DACHANG LITEON
16	MI	2	EA	C109,C110	KMF 68uF 450V M RB P7.5 Φ18X31.5 SK 68uF 450V M RB P7.5 Φ18X30	CAPACITOR, ALUMINUM	SAMYOUNG SUSCON
17	MI	2	EA	CX101,CX102	PCX2 337 0.33uF 275V P15 CTX 0.33uF 275V P15 MPX 0.33uF 275V P15	CAPACITOR, FILM	PILKOR CHENG TUNG EUROPTRONIC
18	MI	1	EA	F100	T5A H 250V 215 RED(1-LINE) T5A H 250V 50CT RED(1-LINE)	FUSE, TIME LAG	LITTELFUSE Dainfuse
19	MI	1	EA	IC102	EL817MB(DT) LTV817M-BN	IC, PHOTO COUPLER	EVERLIGHT LITEON
20	MI	1	EA	TH101	DSC5D15 5Ω 8A Φ15 IN, OUT FORMING MF72-5D15 5Ω 7A Φ15 OUT FORMING WTR15D5 5Ω 8A Φ15 OUT FORMING	THERMISTOR	DSC NSE Xiamen Wanming
21	MI	1	EA	IC202	NR891D DIP-8	IC-DC DC	SANKEN
22	MI	1	EA	PG101	YF-002-00131 SPCC 0.4T GND PIN JS-12-75-04 SPCC 0.4T GND PIN	GND REINFORCE	YAOFENG DIHUA
23	MI	1	EA	L201	13S-DD06 (22uH) EE1614	CHOKE	FEELUX SOOJUNG ZHONGTAI
24	MI	1	EA	L801	12S-DD02(45uH) EE1616	CHOKE	FEELUX SOOJUNG ZHONGTAI



LGP32-13PL1 LCD TV Power specification

25	MI	1	EA	LF101	LLF-124, 28mHLLF-124, 28mHLLF-124, 28mH	LINE FILTER	FEELUX SOOJUNG ZHONGTAI
26	MI	1	EA	T101	13S-LPM01 (EER2934, 300uH)	TRANSFORMER	FEELUX ZHONGTAI
27	MI	1	EA	VA101	INR14D621K-CAP 620V ϕ 14 TUBE VMR14D621K 620V ϕ 14 TUBE SVC621D-14A TW7 620V ϕ 14 TUBE NFC14D621K0037WC 620V ϕ 14 TUBE	VARISTOR	AMOTECH Xiamen Wanming SAMWHA NFC
28	MI	1	EA	SK100	DAC-18C3M1 c	AC SOCKET	DONGIL TECH
29	MI	1	EA	P201	SMAW200-H18S2 18PIN WHITE	WAFER	YEONHO
30	MI	1	EA	P801	SMAW200A-H07AA2 4PIN WHITE	WAFER	YEONHO
	SMT				LGP32-13PL1 SMD COMPONENT	SMT ASSY	
31	SMT	2	EA	C106,C810	330pF 50V J 1608 COG	CAPACITOR, CHIP	YAGEO HEC
32	SMT	2	EA	C104,C808	470pF 50V J 1608 COG	CAPACITOR, CHIP	YAGEO HEC
33	SMT	6	EA	C105,C221,C804,C809,C812, C813	1000pF 50V K 1608 X7R	CAPACITOR, CHIP	YAGEO HEC
34	SMT	1	EA	C218	1200pF 50V K 1608 X7R	CAPACITOR, CHIP	YAGEO HEC
35	SMT	1	EA	C814	0.01uF 50V K 1608 X7R	CAPACITOR, CHIP	YAGEO HEC
36	SMT	9	EA	C107,C108,C202,C210,C215, C217,C219,C806,C807	0.1uF 50V K 1608 X7R	CAPACITOR, CHIP	YAGEO HEC
37	SMT	2	EA	C206,C811	0.47uF 16V K 1608 X7R / 0.47uF 25V K 1608 X7R	CAPACITOR, CHIP	YAGEO HEC
38	SMT	1	EA	C207	0.022uF 50V K 1608 X7R	CAPACITOR, CHIP	YAGEO HEC
39	SMT	1	EA	C220	0.22uF 50V K 2012 X7R	CAPACITOR, CHIP	YAGEO HEC
40	SMT	5	EA	D103,D202,D207,D802,D803	1N4148W 100V 150mA SOD-123 1N4148W 100V 150mA SOD-123	DIODE	TSC DIODES
41	SMT	1	EA	D206	SMAB36 60V 3A SMA	DIODE	KEC
42	SMT	1	EA	ZD203	BZT52C39S 39V SOD-323 BZT52C39S 39V SOD-323	DIODE, ZENER	DIODES TSC
43	SMT	1	EA	Q801	STD20NF20 18A 200V D_PAK AP18N20GH 18A 200V D_PAK FQD18N20V2 15A 200V D_PAK	FET	STM APEC FAIRCHILD
44	SMT	1	EA	Q201	STD10PF06 -60V -10A D-PAK FDD5614P -60V -15A D-PAK AP9578GH -60V -10A D-PAK	FET	STM FAIRCHILD APEC
45	SMT	1	EA	Q802	FDT86106LZ 100V 3.2A SOT-223 PF610BL 100V 0.9A SOT-223 STN4NF20L 200V 1A SOT-223 MDHT4N20Y 200V 0.85A SOT-223	FET	FAIRCHILD NIKO-SEM STM MAGNACHIP
46	SMT	1	EA	Q203	BCW66GLT SOT-23 NPN 2SC5865 SOT-23 NPN	TRANSISTOR	ONSEMI ROHM
47	SMT	1	EA	Q202	KTN2222AS 40V 600mA SOT-23 NPN SBT2222A 40V 600mA SOT-23 NPN	TRANSISTOR	KEC AUK
48	SMT	1	EA	Q803	KTN2907AS -60V -600mA SOT-23 PNP SBT2907A -60V -600mA SOT-23 PNP	TRANSISTOR	KEC AUK
49	SMT	1	EA	IC101	SSC1S311A, SOIC-7	IC	SANKEN
50	SMT	1	EA	IC801	MAP3202SIRH, SOIC-14	IC	MAGNACHIP
51	SMT	1	EA	IC201	SJ432BS 1.24V \pm 0.5% SOT-23 AZ431LANTR-E1 1.24V \pm 0.5% SOT-23	IC	AUK BCD
52	SMT	1	EA	R801	0 Ω J 1608	RESISTOR, CHIP	YAGEO TZAI YUAN
53	SMT	1	EA	R211	2.2 Ω J 1608	RESISTOR, CHIP	YAGEO TZAI YUAN



LGP32-13PL1 LCD TV Power specification

54	SMT	1	EA	R226	4.7Ω J 1608	RESISTOR, CHIP	YAGEO TZAI YUAN
55	SMT	1	EA	R812	10Ω J 1608	RESISTOR, CHIP	YAGEO TZAI YUAN
56	SMT	1	EA	R109	22Ω J 1608	RESISTOR, CHIP	YAGEO TZAI YUAN
57	SMT	1	EA	R106	220Ω J 1608	RESISTOR, CHIP	YAGEO TZAI YUAN
58	SMT	1	EA	R217	470Ω J 1608	RESISTOR, CHIP	YAGEO TZAI YUAN
59	SMT	1	EA	R203	560Ω J 1608	RESISTOR, CHIP	YAGEO TZAI YUAN
60	SMT	6	EA	R105,R204,R805,R806, R807,R817	1KΩ J 1608	RESISTOR, CHIP	YAGEO TZAI YUAN
61	SMT	1	EA	R808	5.1KΩ J 1608	RESISTOR, CHIP	YAGEO TZAI YUAN
62	SMT	2	EA	R104,R210	8.2KΩ J 1608	RESISTOR, CHIP	YAGEO TZAI YUAN
63	SMT	6	EA	R111,R202,R216,R239,R802, R819	10KΩ J 1608	RESISTOR, CHIP	YAGEO TZAI YUAN
64	SMT	1	EA	R233	20KΩ J 1608	RESISTOR, CHIP	YAGEO TZAI YUAN
65	SMT	1	EA	R814	22KΩ J 1608	RESISTOR, CHIP	YAGEO TZAI YUAN
66	SMT	2	EA	R110,R238	47KΩ J 1608	RESISTOR, CHIP	YAGEO TZAI YUAN
67	SMT	1	EA	R212	56KΩ J 1608	RESISTOR, CHIP	YAGEO TZAI YUAN
68	SMT	1	EA	R810	75KΩ J 1608	RESISTOR, CHIP	YAGEO TZAI YUAN
69	SMT	2	EA	R213,R815	100KΩ J 1608	RESISTOR, CHIP	YAGEO TZAI YUAN
70	SMT	1	EA	R209	1.2KΩ F 1608	RESISTOR, CHIP	YAGEO TZAI YUAN
71	SMT	1	EA	R223	2.2KΩ F 1608	RESISTOR, CHIP	YAGEO TZAI YUAN
72	SMT	6	EA	R207,R208,R220,R234,R227, R229	2.4KΩ F 1608	RESISTOR, CHIP	YAGEO TZAI YUAN
73	SMT	1	EA	R813	6.8KΩ F 1608	RESISTOR, CHIP	YAGEO TZAI YUAN
74	SMT	1	EA	R804	10KΩ F 1608	RESISTOR, CHIP	YAGEO TZAI YUAN
75	SMT	2	EA	R224,R225	18KΩ F 1608	RESISTOR, CHIP	YAGEO TZAI YUAN
76	SMT	1	EA	R811	51KΩ F 1608	RESISTOR, CHIP	YAGEO TZAI YUAN
77	SMT	1	EA	R235	56KΩ F 1608	RESISTOR, CHIP	YAGEO TZAI YUAN
78	SMT	2	EA	R205,R206	120KΩ F 1608	RESISTOR, CHIP	YAGEO TZAI YUAN
79	SMT	1	EA	R803	430KΩ F 1608	RESISTOR, CHIP	YAGEO TZAI YUAN
80	SMT	4	EA	R823,R825,R827,R829	3.9Ω F 2012	RESISTOR, CHIP	YAGEO TZAI YUAN



LGP32-13PL1 LCD TV Power specification

81	SMT	1	EA	J3	0Ω J 3216	RESISTOR, CHIP	YAGEO TZAI YUAN
82	SMT	1	EA	R816	7.5Ω J 3216	RESISTOR, CHIP	YAGEO TZAI YUAN
83	SMT	2	EA	R112,R236	10Ω J 3216	RESISTOR, CHIP	YAGEO TZAI YUAN
84	SMT	1	EA	R107	22Ω J 3216	RESISTOR, CHIP	YAGEO TZAI YUAN
85	SMT	1	EA	R818	47Ω J 3216	RESISTOR, CHIP	YAGEO TZAI YUAN
86	SMT	1	EA	R108	100Ω J 3216	RESISTOR, CHIP	YAGEO TZAI YUAN
87	SMT	4	EA	R201,R214,R215,R228	240Ω J 3216	RESISTOR, CHIP	YAGEO TZAI YUAN
88	SMT	2	EA	R830,R831	150KΩ F 3216	RESISTOR, CHIP	YAGEO TZAI YUAN
89	SMT	0.5	GR		NE8800T	BOND	FUJI
	AI				LGP32-13PL1 AI COMPONENTS	AI ASSY	
90	AI	1	EA	C203	NXB 470uF 50V M P5 Φ12.5X20 SG 470uF 50V M P5 Φ12.5*20	CAPACITOR, ALUMINUM	SAMYOUNG SUSCON
91	AI	1	EA	C201	NXB 1500uF 10V M P5 Φ10X20 SG 1500uF 10V M P5 Φ10X20	CAPACITOR, ALUMINUM	SAMYOUNG SUSCON
92	AI	1	EA	C209	NXB 470uF 10V M P5 Φ8X11.5 SG 470uF 10V M P5 Φ8*12	CAPACITOR, ALUMINUM	SAMYOUNG SUSCON
93	AI	2	EA	C103,C208	NXB 100uF 50V M P5 Φ8X11.5 SG 100uF 50V M P5 Φ 8*12	CAPACITOR, ALUMINUM	SAMYOUNG SUSCON
94	AI	2	EA	C204,C214	NXB 100uF 100V M P5 Φ12.5X20 MF 100uF 100V M P5 Φ13*21	CAPACITOR, ALUMINUM	SAMYOUNG SUSCON
95	AI	1	EA	C222	NXB 220uF 25V M P5 Φ8X11.5 SG 220uF 25V M P5 Φ8*12	CAPACITOR, ALUMINUM	SAMYOUNG SUSCON
96	AI	1	EA	C801	NFK 68uF 160V M P5 Φ12.5X20 SG 68uF 160V M P5 Φ12.5X20	CAPACITOR, ALUMINUM	SAMYOUNG SUSCON
97	AI	3	EA	CY101,CY102,CY111	CD 100pF 250V K P10, Y1 CT81 100pF 250V K P10, Y1	CAPACITOR, CERAMIC	TDK YINANDON
98	AI	1	EA	CY110	CD 330pF 250V K P10, Y1 CT81 330pF 250V K P10, Y1	CAPACITOR, CERAMIC	TDK YINANDON
99	AI	2	EA	CY103,CY104	CD 1000pF 250V M P10, Y1 CT81 1000pF 250V M P10, Y1	CAPACITOR, CERAMIC	TDK YINANDON
100	AI	3	EA	C102,C211,C213	CT81 330pF 1KV K P5 125℃ CK45 330pF 1KV K P5 125℃ CT81 330pF 1KV K P5 125℃	CAPACITOR, CERAMIC	YINANDON TDK Kunshan Wansheng
101	AI	3	EA	C101,C111,C112	CT81 1000pF 1KV K P5 125℃ CK45 1000pF 1KV K P5 125℃ CT81 1000pF 1KV K P5 125℃	CAPACITOR, CERAMIC	YINANDON TDK Kunshan Wansheng
102	AI	2	EA	D102,D104	UF4007 1KV 1A DO-41 UF4007 1KV 1A DO-41	DIODE	TSC DACHANG
103	AI	1	EA	ZD202	P6KE30A 600W DO-15	DIODE, ZENER	TSC
104	AI	4	EA	ZD102,ZD103,ZD105,ZD201	1N5246B 16V DO-35	DIODE, ZENER	TSC
105	AI	18	EA	EL3,EL4,EL5,EL6,EL7, EL8,EL17,EL22,EL23,EL24, EL25,EL26,EL27,EL28,EL29, EL31,EL32,EL98	1.6X3.0	EYELET	YAOFENG DELIKANG
106	AI	13	EA	EL1,EL2,EL11,EL12,EL13, EL14,EL15,EL16,EL18,EL19, EL20,EL21,EL30	2.0X3.0	EYELET	YAOFENG DELIKANG
107	AI	5	EA	P202,P203,P204,P802,P803	SSJS236-6-3 (6mm Under)	GT PIN	YAOFENG DELIKANG
108	AI	4	EA	LB101,LB102,LB104,LB201	BFS3550R2F SINGLE RADIAL	INDUCTOR, BEAD FILTER LEAD	SAMWHA



LGP32-13PL1 LCD TV Power specification

109	AI	1	EA	LB801	BFS3550R2F SINGLE RADIAL	INDUCTOR, BEAD FILTER LEAD	SAMWHA
110	AI	16	EA	J1,J2,J11,J14,J18, J20,J21,J22,J23, J26,J27,J28,J30,J31, J34,J36	Φ0.6	JUMPER WIRE	TZAI YUAN HUIHUA
111	AI	1	EA	R832	CF 1KΩ 1/6W J SMALL	RESISTOR, CARBON FILM	TZAI YUAN
112	AI	1	EA	R101	MSR37 1.2MΩ 1/2W J SURGE	RESISTOR, FIXED CARBON COMPOSITION	PILKOR
113	AI	1	EA	R103	MOF 22KΩ 1W J SMALL	RESISTOR, METAL OXIDE FILM	TZAI YUAN
114	AI	2	EA	R218,R221	MOF 10Ω 1W J SMALL R-FORMING	RESISTOR, METAL OXIDE FILM	TZAI YUAN
115	AI	1	EA	R102	MOF 62KΩ 2W J SMALL R-FORMING	RESISTOR, METAL OXIDE FILM	TZAI YUAN
116	AI	1	EA	R820	WNPS 0.12Ω 2W J SMALL R-FORMING SMW 0.12Ω 2W J SMALL R-FORMING	RESISTOR, WIRE WOUND	ABCO SMART
117	AI	1	EA	R113	WNPS 0.25Ω 2W J SMALL PRN 0.25Ω 2W J SMALL	RESISTOR, WIRE WOUND	ABCO SMART
118	AI	1	EA	PCB	LGP32-13PL1 (159 * 121 * 1.6T) FR-1 KB,DS,L, 1oz CTI-600	PCB	SHANGHAI WANZHENG NEW TRIUNION WYT
	ETC				LGP32-PL1 SUBSIDIARY MATERIALS		
119	ETC	1	EA		40X8 NY WHITE 93CODE 19DIGIT	BAR CODE	QIUJING
120	ETC	3.00	GR		ES2044H & ES2482W SD-5 UB-5601	BOND (RTV)	CANADA SANCHEN U-BOND
121	ETC	0.0333	EA		600 X 500 X 195 X T8	BOX CARTON	WUJIANG ZHENLONG SUZHOU JIADELONG
122	ETC	0.0667	EA		485 X 170 X T8	BOX PARTITION	WUJIANG ZHENLONG SUZHOU JIADELONG
123	ETC	0.3667	EA		585 X 170 X T8	BOX PARTITION	WUJIANG ZHENLONG SUZHOU JIADELONG
124	ETC	1.00	EA		130 X 380	BUBBLE SHEET	LIYUAN WINWORLD
125	ETC	25	GR		ILF-710(kg)	FLUX	ION ELEC
126	ETC	15	GR		SAC0307 A+ SN:99%, AG:0.3%, CU:0.7%	SOLDER BAR	DYFENCO
127	ETC	5	GR		SAC0307 A+ SN:99%, AG:0.3%, CU:0.7%	SOLDER WIRE	DYFENCO



Process Marking



공정표시 MARK (PCB SILK)

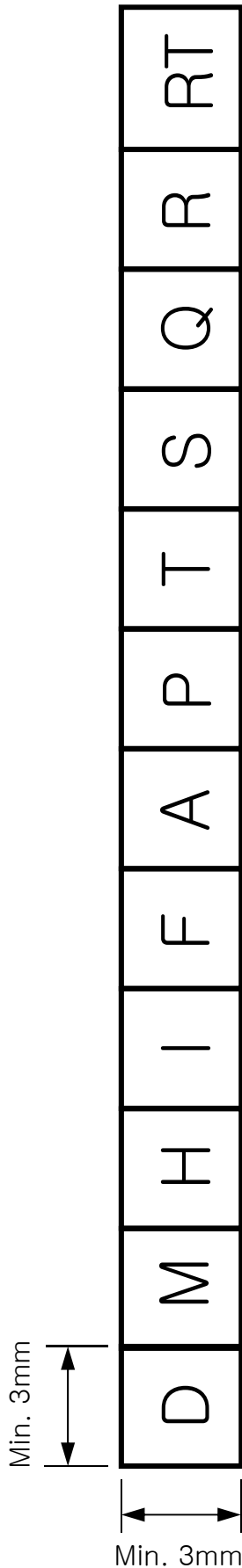

- D : 자삽
- M : SMD
- H : 수삽 최종
- I : ICT
- F : 1차 성능
- A : AGING
- P : HI-POT
- T : 최종 검사 (ATE)
- S : SET 검사
- Q : QC 검사
- R : 불량 수리
- RT : 양산 보증 시험



PCB Layout



Top Silk

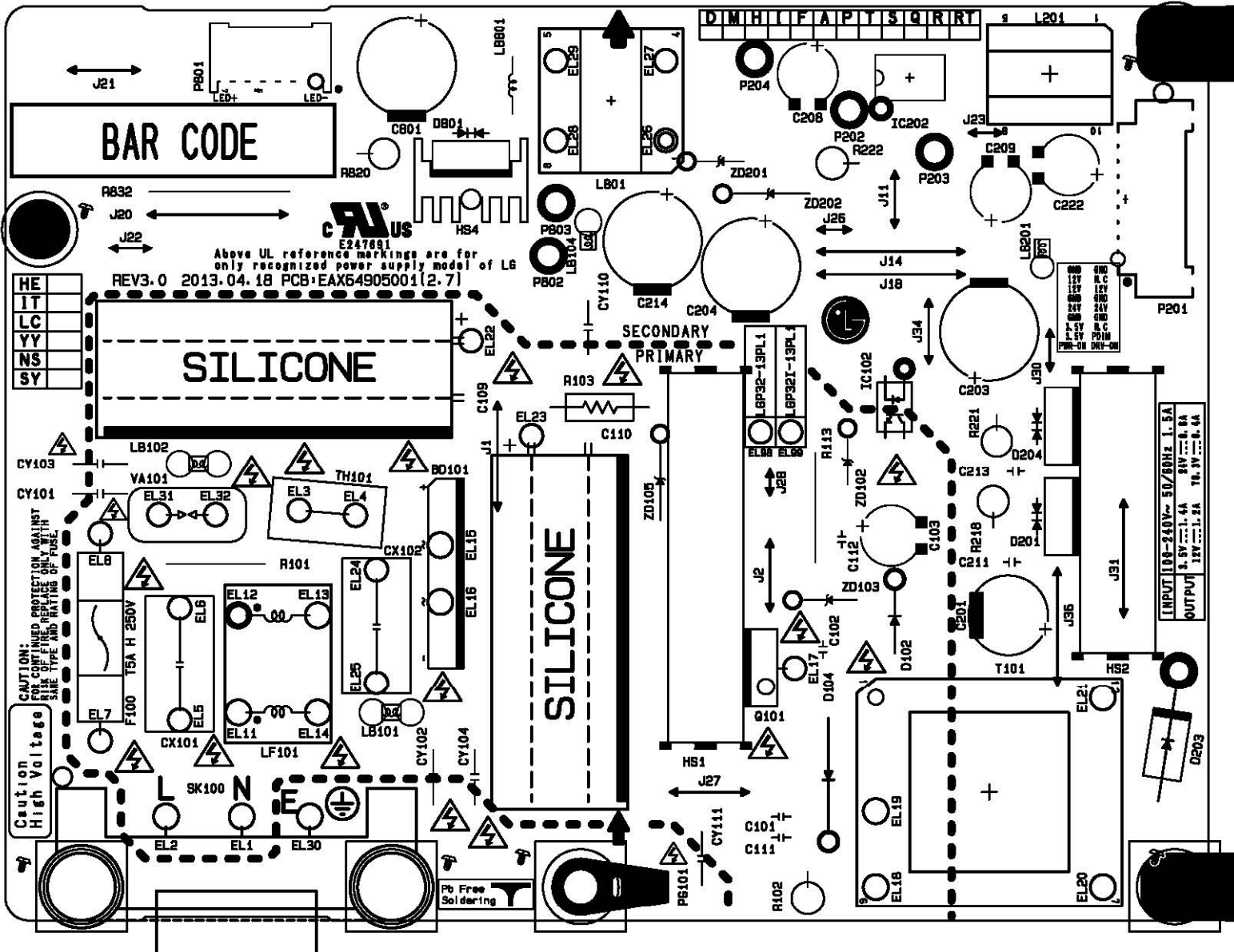



Bottom Silk :

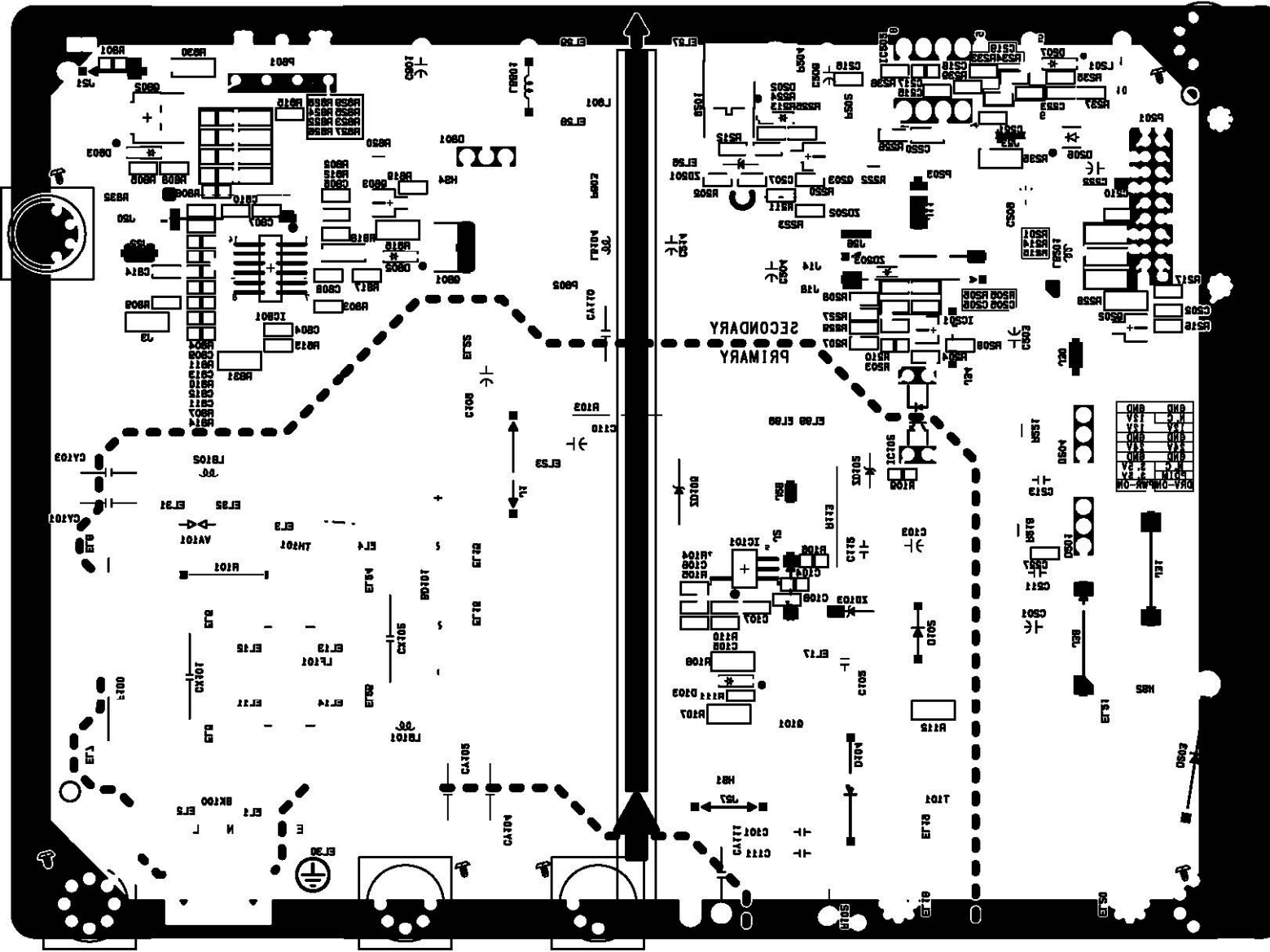



Bottom Pattern :

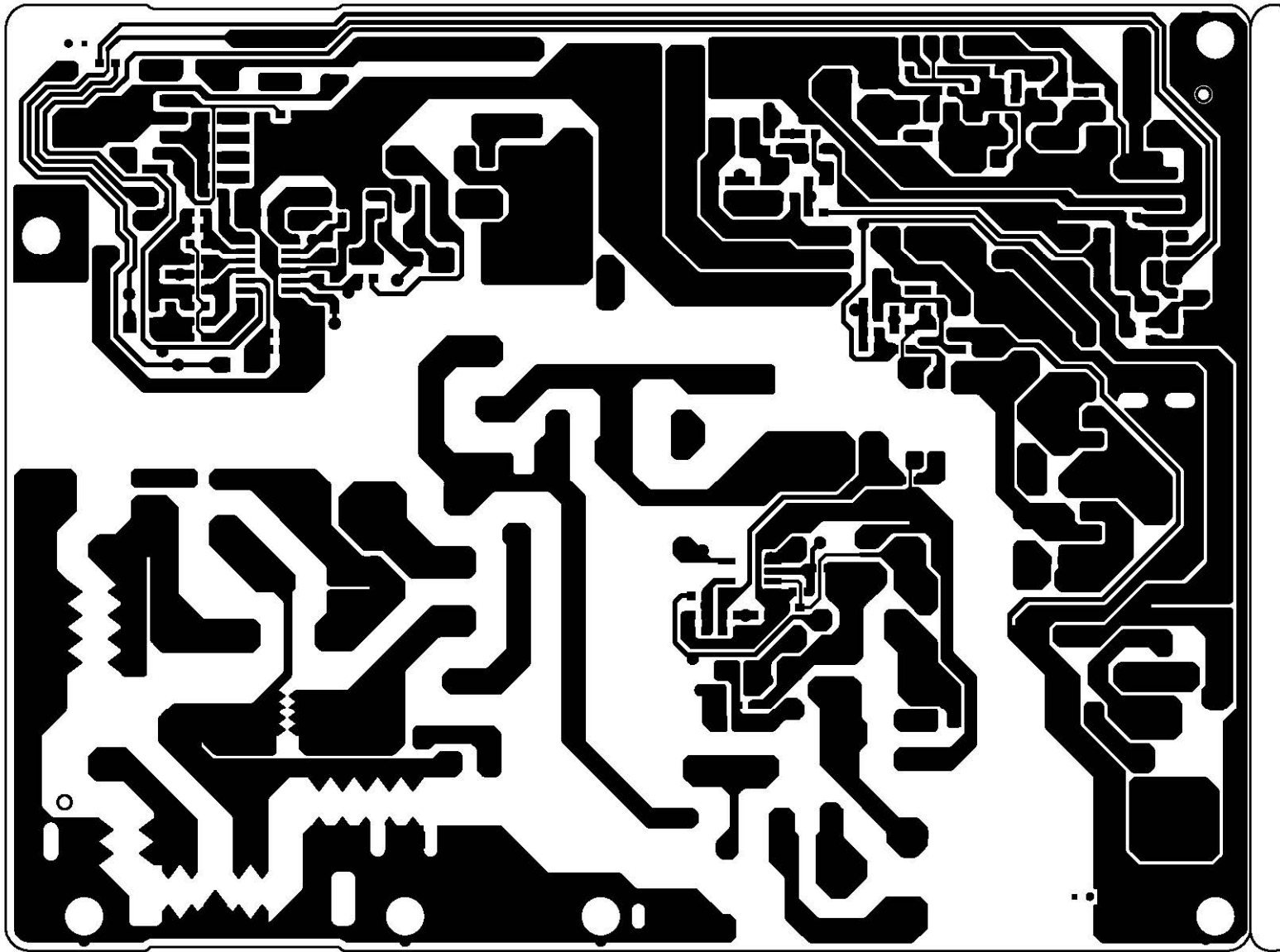



Bottom Solder mask :

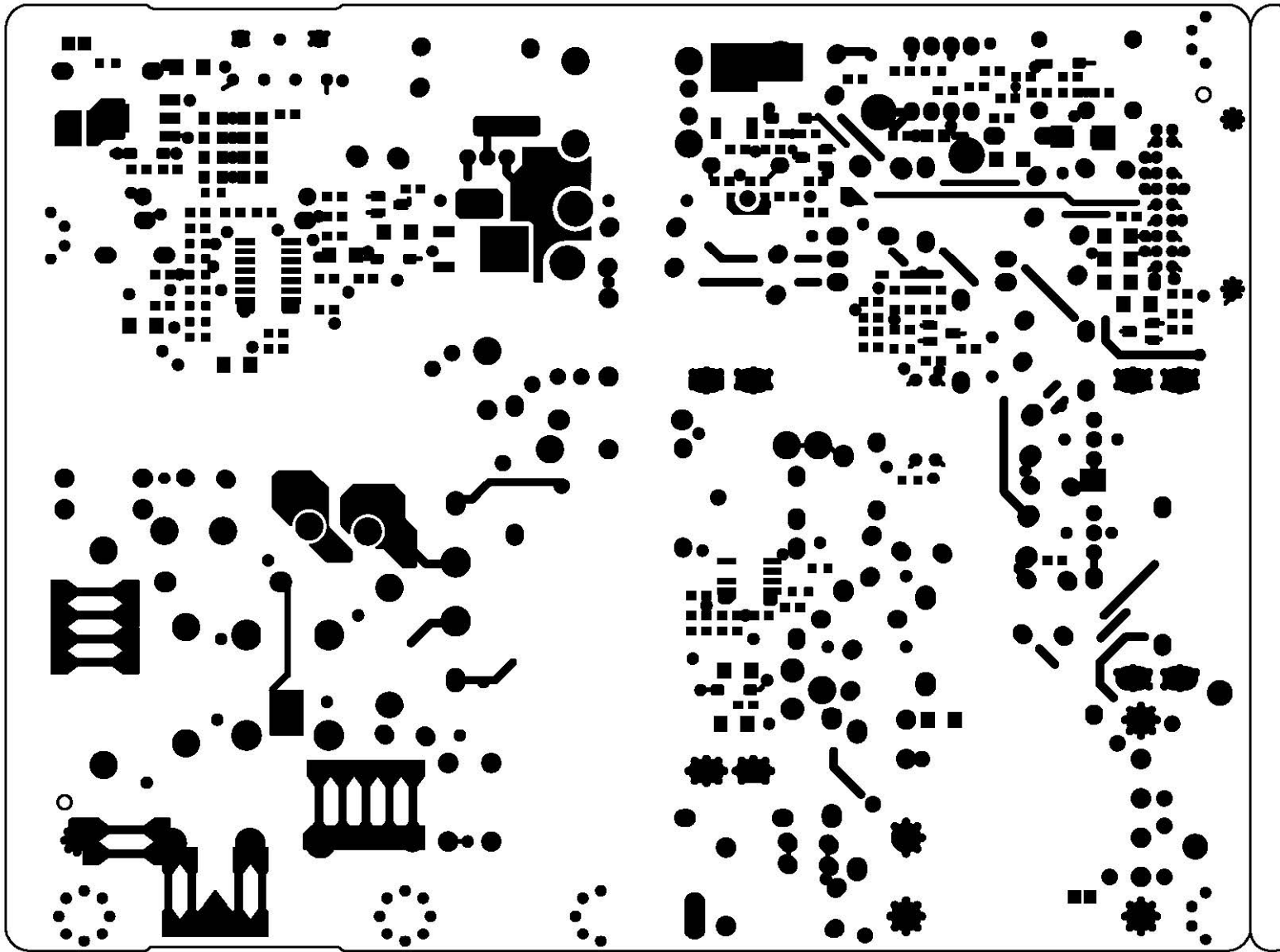



Safety Parts



LGP32-13PL1 LCD TV Power specification

Object/part No.	Manufacturer / Trademark	Type / Model	Value / Rating	Parts Marking (實物)	standard	mark(s) of conformity1)	
AC input connector. (SK100)	Dongil Tech	DAC-18C3M1	250V / 2.5A	DAC-18C3M1	IEC 60320-1		
Fuse. (F100)	Littelfuse Inc.	215 Series	T5A H / 250V	LF.T5AH250VP	IEC 60127-2		
	WALTER FUSE	TSC		TSC5A250V(P)	IEC 60127		
	BUSSMANN	S505		T5AH250V	IEC 60127-2		
	Dainfuse	50CT		T5AH 250V	IEC 60127		
	CONQUIRE	UDA-A		UDA-A T5A H 250V	IEC 60127-3-5		
Line Filter.(LF101)	TNC	CV620280SH(HF)	Rated 130°C	G20280 S3	IEC 60065	Test in appliance	
	Dongil Tech	LSD020280		G20280			
	PEELUX	LLF-124		LLF-124			
	ZHONGTAI						
	JIANGSU CHANNELON ELECTRONIC GROUP						
	SOOJUNG						
DONG YANG TELECOM CO., LTD							
Base material of Linefilter (LF101)	MOMENTIVE SPECIALTY CHEMICALS GMBH	PF 2736	V-0, 150°C		UL, E61040	UL	
Alt	Chang Chun Plastics Co., Ltd	T375HF, T375J	V-0, 150°C		UL, E59481	UL	
Alt	LG CHEMICAL LTD	LUPOX GP-2306F	V-0, 140°C		UL, E67171	UL	
Alt	NAN YA PLASTICS CORP PLASTICS 4TH DIV	1403G3, 1403G6	V-0, 130°C		UL, E130155	UL	
Alt	SAMYANG CORPORATION	1500GN-30	V-0 130°C		UL, E121254	UL	
Alt	Rhodia Engineering plastics	A 50H1	V-0, 130°C		UL, E44716	UL	
Alt	Sabic Innovative Plastics japan LLC	420SE0	V-0, 130°C		UL, E45587	UL	
Alt	TORAY INDUSTRIES INC	A604 E604	V-0, 130°C		UL, E41797	UL	
Alt	POLY PLASTICS CO., LTD	1140A66	V-0, 130°C		UL, E109088	UL	
Alt	SK CHEMICALS CO., LTD	Ecotran 1040G	V-0, 130°C		UL, E215991	UL	
Varistor. (VA101)	Samwha	SVC621D-14A	Climatic category: 40/085/21 Maximum continuous voltage:385Va.c. Current pulse rating: 6 kV/3 kA	SVC 621-14	CECC 42000 CECC 42200 CECC 42201 IEC 60065 Clause 14.12 and IEC 60950-1 Annex Q		
	Amotech Co., Ltd.	INR 14D621K	Climatic category: 40/085/56 Maximum continuous voltage: 385Va.c. Current pulse rating: 6 kV/3 Ka	INR 14D621	CECC42000/A1 CECC42200/A1 CECC 42201-001 IEC 61051-1 IEC 61051-2 IEC 61051-2-2 IEC 60065 Clause 14.12 and IEC 60950-1 Annex Q		
	Xiamen Wanming Electronics Co.,Ltd	WMR14D621K	Climatic category: 40/85/56 Maximum continuous voltage: 750Va.c. Current pulse rating: 6 kV/3 kA	WMR 14D621K	IEC 61051-1 IEC 61051-2 IEC 61051-2-2 IEC 60950-1 Annex Q		
	Guangxi New Future Information Industry Co.,Ltd	NFC 14D621K	Climatic category: 40/085/21 Maximum continuous voltage:385Va.c. Current pulse rating: 6 kV/3 kA	NFC 14D621K	IEC 61051-1 IEC 61051-2 IEC 61051-2-2 IEC 60950-1 Annex Q		
Bridge Diode. (BD101)	Lite-on	KBJ1006G	Min 600V / 10A	KBJ1006G	Test in appliance		
	DACHANG	D10XB60		D10XB60			
	TSC	TS10K60		TS10K60			E96005
	GULF	G10XB60		G10XB60			
	RECTRON	RS1007M		RS1007M			
	SHINDENGEN	D10XB60		D10XB60			E142422
X-cap. (CX101)	Pilkor	PCX2 337	Min 275V~ / (CX101= Max 0.47uF)	PCX2 337 MKP	IEC 60384-14 UL1414		
	Okaya	LE		LE	IEC 60384-14 UL1414		
	EUROPTRONIC	MPX		MPX	E199061/ E311052 IEC 60384-14-3'nd edition		
	CHENG TUNG	CTX		CTX	IEC 60384-14 UL1414		
X-cap. (CX102)	Pilkor	PCX2 337	Min 275V~ / (CX102= Max 0.22uF)	PCX2 337 MKP	IEC 60384-14 UL1414		
	Okaya	LE		LE	IEC 60384-14 UL1414		
	EUROPTRONIC	MPX		MPX	E199061/ E311052 IEC 60384-14-3'nd edition		
	CHENG TUNG	CTX		CTX	IEC 60384-14 UL1414		
Thermistor. (TH101)	DSC	DSC 5D-15	5ohm at 25 ° C	DSC 5D-15	IEC 60065		
	Xiamen Wanming Electronics Co.,Ltd	WTR15D050M		WTR15D050			
	JIANGSU XINGSHUN ELECTRONICS CO., LTD	5D2-15		5D2-15			
	Smart	ICL-5W		ICL-05 5R00MSMT			
	NANJING SHIHENG ELECTRONICS CO., LTD	MF72-5D15		MF72 5D15			
Elec. Cap. (C109, C110)	KAMYUNG	KMF450V68uF	450V / Max 68uF / 105°C	KMF450V68uF	IEC 60950-1	Test in appliance	
	SUSCON	SK		SK450V68uF			
	SAMYOUNG	NZE	500V / Max 100uF / 105°C	NZE500V100uF	IEC 60950-1	Test in appliance	
	SUSCON	SK		SK500V100uF			
	Switching TR. (Q101)	MAGNACHIP	MDF11N65B	Min. 650V / Min 7A	MDF11N65B	IEC 60950-1	Test in appliance
	TOSHIBA	TK8A65D		TK8A65D			



Y Cap. (CY101,CY102)	Kunshan Wansheng	Y1 / CT7	Min 250V / (CY101= Max 100pF, CY102= Max 100pF)	CT7 101K	IEC 60384-14	
	Apex intec	Y1 / NK		NK101K		
	DONG IL	Y1 / DA		DA101K		
	YINANDON	Y1 / CT81		CT81 101K		
	SAMWHA	Y1 / SD		SD101K		
	JYA-NAY	Y1 / JN		JN101K		
Bridging Cap.(CY103,CY104)	Kunshan Wansheng	Y1 / CT7	Min 250V / (CY103= Max 1000pF, CY104= Max 1000pF)	CT7 102M	IEC 60384-14	
	Apex intec	Y1 / NK		NK102M		
	DONG IL	Y1 / DA		DA102M		
	YINANDON	Y1 / CT81		CT81 102M		
	SAMWHA	Y1 / SD		SD102M		
	JYA-NAY	Y1 / JN		JN102M		
Y Cap. (CY110)	Kunshan Wansheng	Y1 / CT7	Min 250V / Max 330pF	CT7 331K	IEC 60384-14	
	Apex intec	Y1 / NK		NK331K		
	DONG IL	Y1 / DA		DA331K		
	YINANDON	Y1 / CT81		CT81 331K		
	SAMWHA	Y1 / SD		SD331K		
	JYA-NAY	Y1 / JN		JN331K		
Y Cap. (CY111)	Kunshan Wansheng	Y1 / CT7	Min 250V / Max 100pF	CT7 101K	IEC 60384-14	
	Apex intec	Y1 / NK		NK101K		
	DONG IL	Y1 / DA		DA101K		
	YINANDON	Y1 / CT81		CT81 101K		
	SAMWHA	Y1 / SD		SD101K		
	JYA-NAY	Y1 / JN		JN101K		
Switching Transformer, (T101)	PEELUX	13S-LPM01	Class B, 130°C	13S-LPM01	IEC 60950-1	Test in appliance
	JIANGSU CHANNELON ELECTRONIC GROUP					
	SOOJUNG					
	ZHONGTAI					
	NAMYANG					
Bobbin material of transformer (T101)	SUMITOMO BAKELITE CO LTD	PM-9820/PM-9630	V=0, 150°C		UL E41429	UL
Insulating Tape of transformer (T101)	DUCK SUNG HITECH CO LTD	DTS-204	130°C		UL E105147	UL
Alt	METAL LINE CO., LTD	800(a)	130°C		UL E162848	UL
Alt	JINGJIANG YAHUA PRESSURE SENSITIVE	CT/PZ	130°C		UL E165111	UL
Alt	3M Company	1350F-1	130°C		UL E17385	UL
Opto-coupler, (IC102)	Everlight	EL817	External cr: 7.7 mm, Internal cr: 6.0 mm DTI: 0.5 mm / 6000 Vrms	EL817	IEC 60065 UL 1577	
	Lite-on	LTV817...	External cr: 7.8 mm, Internal cr: 5.2 mm DTI: 0.8 mm / 6000 Vrms	817RN		
Discharge Resistor, (R101)	Smart	PRC	1/2W, 1Mohm, 5%		IEC 60065	
	UNIROYAL ELECTRONICS INDUSTRY CO., LTD	MGR0W2J****A10				
	Pilkor	SR37_MSR37				
PCB, FR-1	DONGMYUNG CIR.	DM5-V-0	94V-0			
	SHANGHAI WANZHENG	SWZ-2	94V-0			
	WYT (Wan Yuan Tong)	SWZ-2	94V-0			
	SHANGHAI AREX	02V0	94V-0			
	NEW TRIUNION	TU-3	94V-0			
	CHIN POON	E5 ED1	94V-0			
	TIANJIN DAEDUCK	DC-1 DC-2	94V-0			
	HUIHO	4B-5 4B-1, 4B-2, 4D	94V-0			
	HSIANG KUO	07V0	94V-0			
	SAMHAN	SH7	94V-0			
	HT CIRCUIT(QINGDAO)	1794V0	94V-0			
	WONKYUNG	WK-1	94V-0			
	TIAN FENG	TU-1	94V-0			
	Duck sung	DS8-V-0	94V-0			
	TIS KOREA	TIS-3	94V-0			
	kyosha	2294V-0	94V-0			
	kyosha	S4594V-0	94V-0			
	Wellbest	MTV0-01	94V-0			
	Cosmotech	GS2-V-0-1 CJ2-V-0-1 CJ2-V-0-2	94V-0			
	CHANGZHOU HATHONG	CCE-V0	94V-0			



Mechanical Drawing

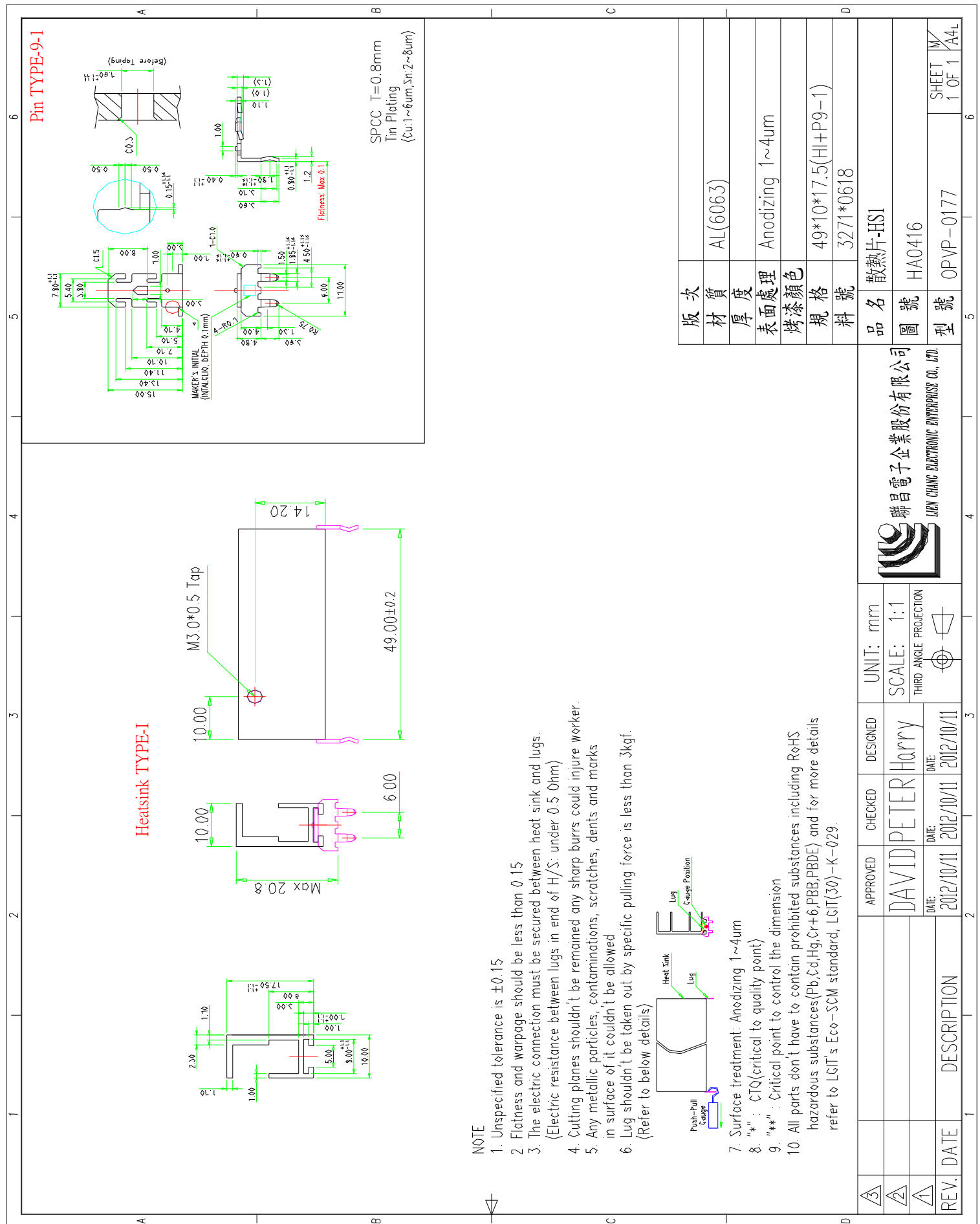



LGP32-13PL1 LCD TV Power specification

<p>Pin TYPE-9-1</p> <p>SPCC, T=0.8mm Tin Plating (Cu:1~6um, Sn:2~8um)</p>	<p>Heatsink TYPE-I</p>	<p>NOTE</p> <ol style="list-style-type: none"> 1. Unspecified tolerance is ± 0.15 2. Flatness and warpage should be less than 0.15 3. The electric connection must be secured between heat sink and lugs. (Electric resistance between lugs in end of H/S: under 0.5 Ohm) 4. Cutting planes shouldn't be remained any sharp burrs could injure worker. 5. Any metallic particles, contaminations, scratches, dents and marks in surface of it couldn't be allowed 6. Lug shouldn't be taken out by specific pulling force is less than 3kgf. (Refer to below details) 	<p>Table 1: Material and Surface Treatment</p> <table border="1"> <tr><td>版次</td><td>AL(6063)</td></tr> <tr><td>材質</td><td>AL(6063)</td></tr> <tr><td>厚度</td><td>Anodizing 1~4um</td></tr> <tr><td>表面處理</td><td>Anodizing 1~4um</td></tr> <tr><td>烤漆顏色</td><td>37*10*17.5(HI+P9-1)</td></tr> <tr><td>規格</td><td>3271*0633</td></tr> <tr><td>料號</td><td></td></tr> </table>	版次	AL(6063)	材質	AL(6063)	厚度	Anodizing 1~4um	表面處理	Anodizing 1~4um	烤漆顏色	37*10*17.5(HI+P9-1)	規格	3271*0633	料號		<p>Table 2: Product Information</p> <table border="1"> <tr><td>品名</td><td>散熱片-HS2</td></tr> <tr><td>圖號</td><td>HA0430</td></tr> <tr><td>型號</td><td>OPVP-0177</td></tr> <tr><td>SHEET</td><td>1 OF 1</td></tr> <tr><td>A4L</td><td></td></tr> </table>	品名	散熱片-HS2	圖號	HA0430	型號	OPVP-0177	SHEET	1 OF 1	A4L	
版次	AL(6063)																											
材質	AL(6063)																											
厚度	Anodizing 1~4um																											
表面處理	Anodizing 1~4um																											
烤漆顏色	37*10*17.5(HI+P9-1)																											
規格	3271*0633																											
料號																												
品名	散熱片-HS2																											
圖號	HA0430																											
型號	OPVP-0177																											
SHEET	1 OF 1																											
A4L																												
<p>聯昌電子企業股份有限公司 LIEN CHANG ELECTRONIC ENTERPRISE CO., LTD.</p>		<p>UNIT: mm SCALE: 1:1 THIRD ANGLE PROJECTION</p>	<p>APPROVED: DAVID PETER HARRY DATE: 2012/11/30</p> <p>DESIGNED: HARRY DATE: 2012/11/30</p>	<p>REV. DATE DESCRIPTION</p>																								

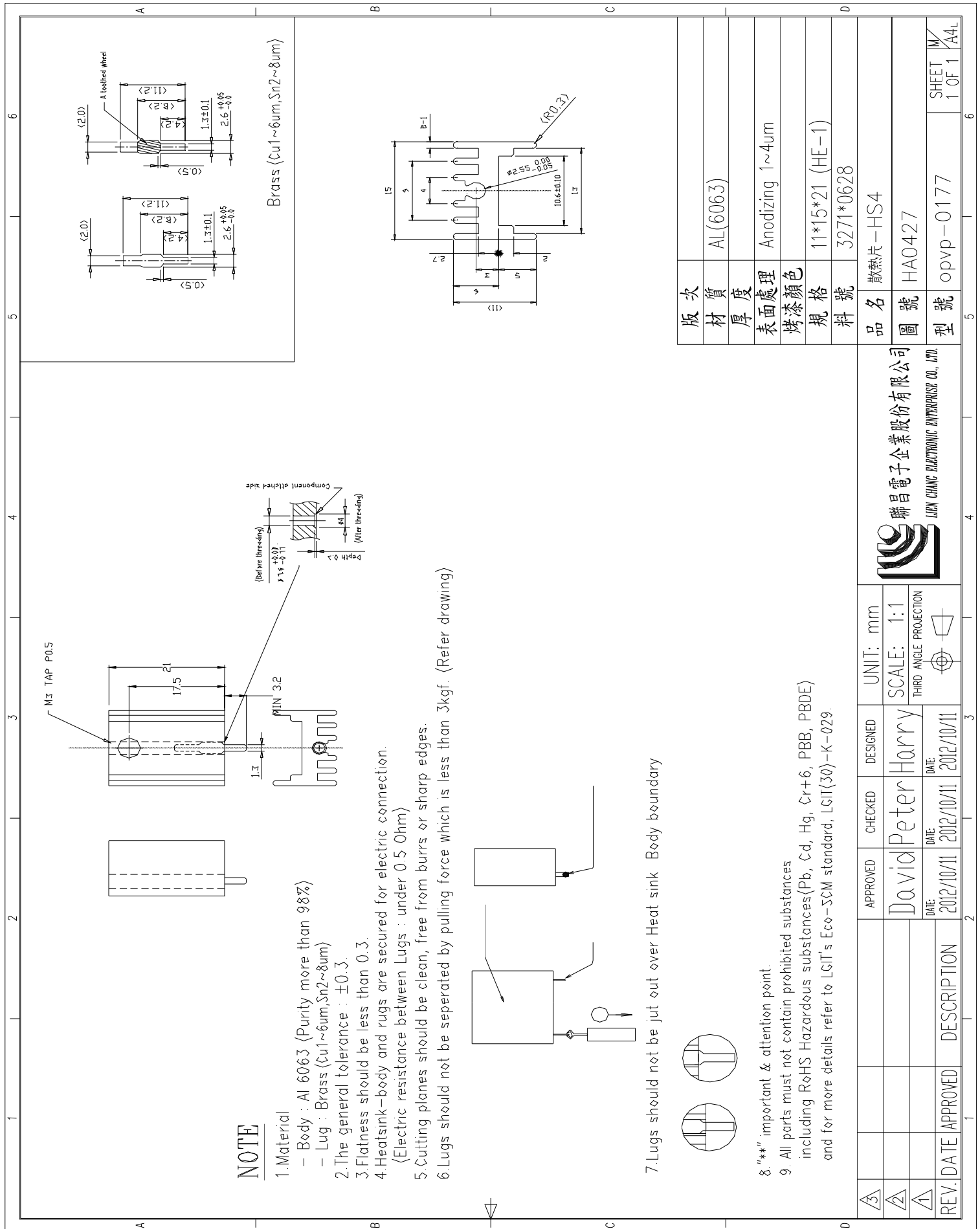

版次	
材質	AL(6063)
厚度	
表面處理	Anodizing 1~4um
烤漆顏色	
規格	11*15*21 (HE-1)
料號	3271*0628
品名	散熱片-HS4
圖號	HA0427
型號	opvp-0177

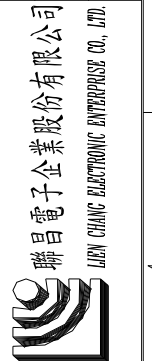

APPROVED	CHECKED	DESIGNED	UNIT: mm
DATE: 2012/10/11	DATE: 2012/10/11	DATE: 2012/10/11	SCALE: 1:1
David	Peter	Harry	THIRD ANGLE PROJECTION
DATE: 2012/10/11	DATE: 2012/10/11	DATE: 2012/10/11	
REV.	DATE	APPROVED	DESCRIPTION



Packing Drawing



NO.	DESCRIPTION	QTY	MATERIAL	Remark
1	CORTON BOX	1 / 39	600x500x195xt8	
2	PARTITION A	17 / 39	485x170xt8	
3	PARTITION B	8 / 39	585x170xt8	
4	BUBBLE SHEET	39 / 39	130x380mm	
5	POWER BOARD	39 / 39	159x121x26.1mm	

QTY: 40 BOX * 39 SET = 1560 SETS
MAX 10 Tire

NOTE:
1 CARTON SET : 39 Sets

3		UNIT: mm		DESIGNED		APPROVED	
2		SCALE: 1:1		CHECKED		DATE:	
1		THIRD ANGLE PROJECTION		劉北偉	Sally Chen	DATE:	DATE:
REV.	DATE	APPROVED	DESCRIPTION	2010/10/21	2010/10/21	2010/10/21	2010/10/21

品名	500*600*195mm CARTON 組裝圖						料號
型號	AIP-0208						SHEET
M/A4L							1 OF 1

聯昌電子企業股份有限公司
LIEN CHANG ELECTRONIC ENTERPRISE CO., LTD.



LGP32-13PL1 LCD TV Power specification

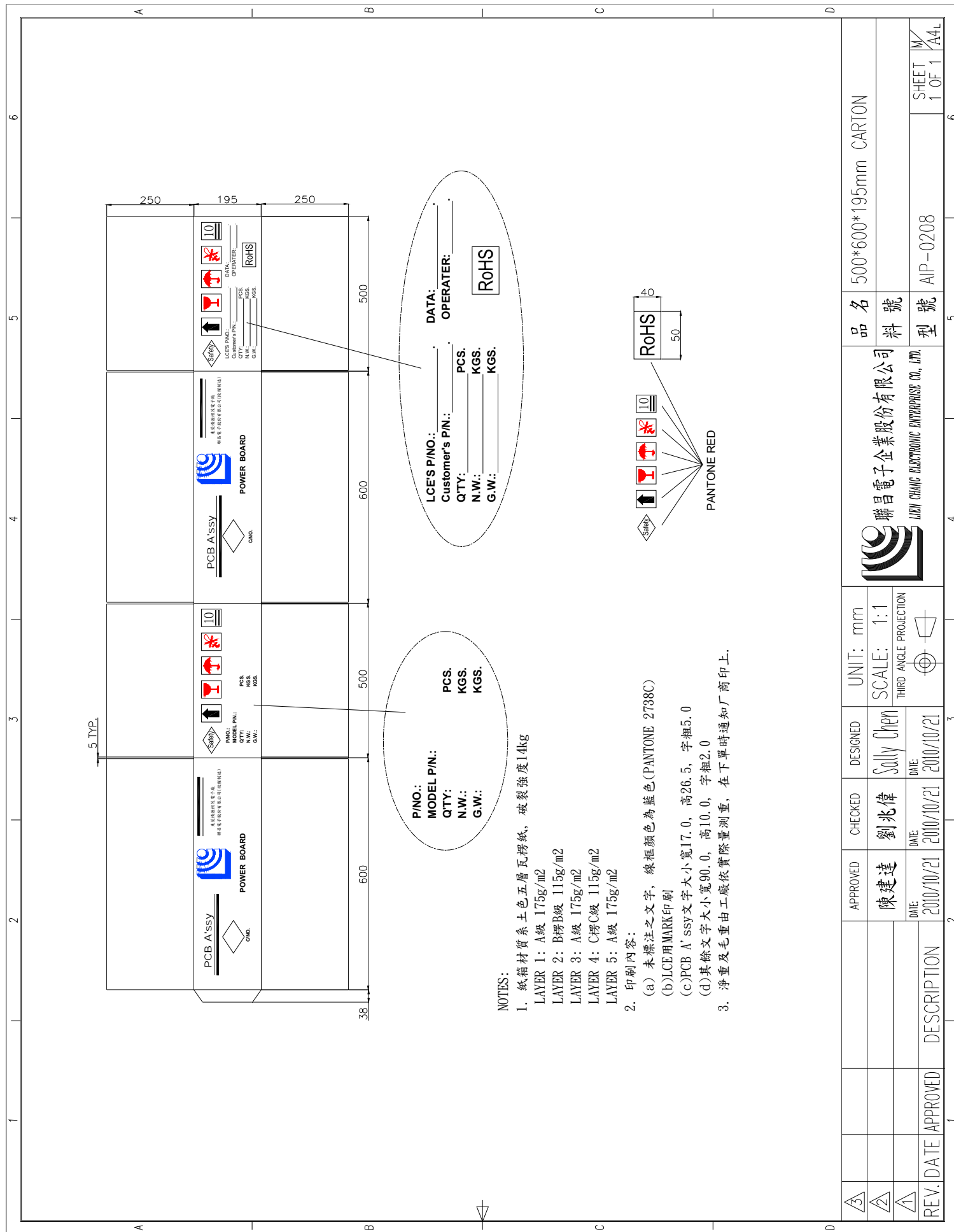

NOTES:

- 紙箱材質系土色五層瓦楞紙，破裂強度14kg
LAYER 1: A級 175g/m²
LAYER 2: B楞B級 115g/m²
LAYER 3: A級 175g/m²
LAYER 4: C楞C級 115g/m²
LAYER 5: A級 175g/m²
- 印刷內容:
(a) 未標注之文字，線框顏色為藍色(PANTONE 2738C)
(b) LCE用MARK印刷
(c) PCB A'ssy文字大小寬17.0，高26.5，字粗5.0
(d) 其餘文字大小寬90.0，高10.0，字粗2.0
- 淨重及毛重由工廠依實際量測重，在下單時通知廠商印上。

3		APPROVED	CHECKED	DESIGNED	UNIT: mm	品名	500*600*195mm CARTON
2			劉兆偉	Sally Chen	SCALE: 1:1	料號	
1			陳建達		THIRD ANGLE PROJECTION	型號	AIP-0208
REV. DATE	APPROVED	DESCRIPTION	DATE: 2010/10/21	DATE: 2010/10/21	DATE: 2010/10/21		SHEET 1 OF 1
							A4L

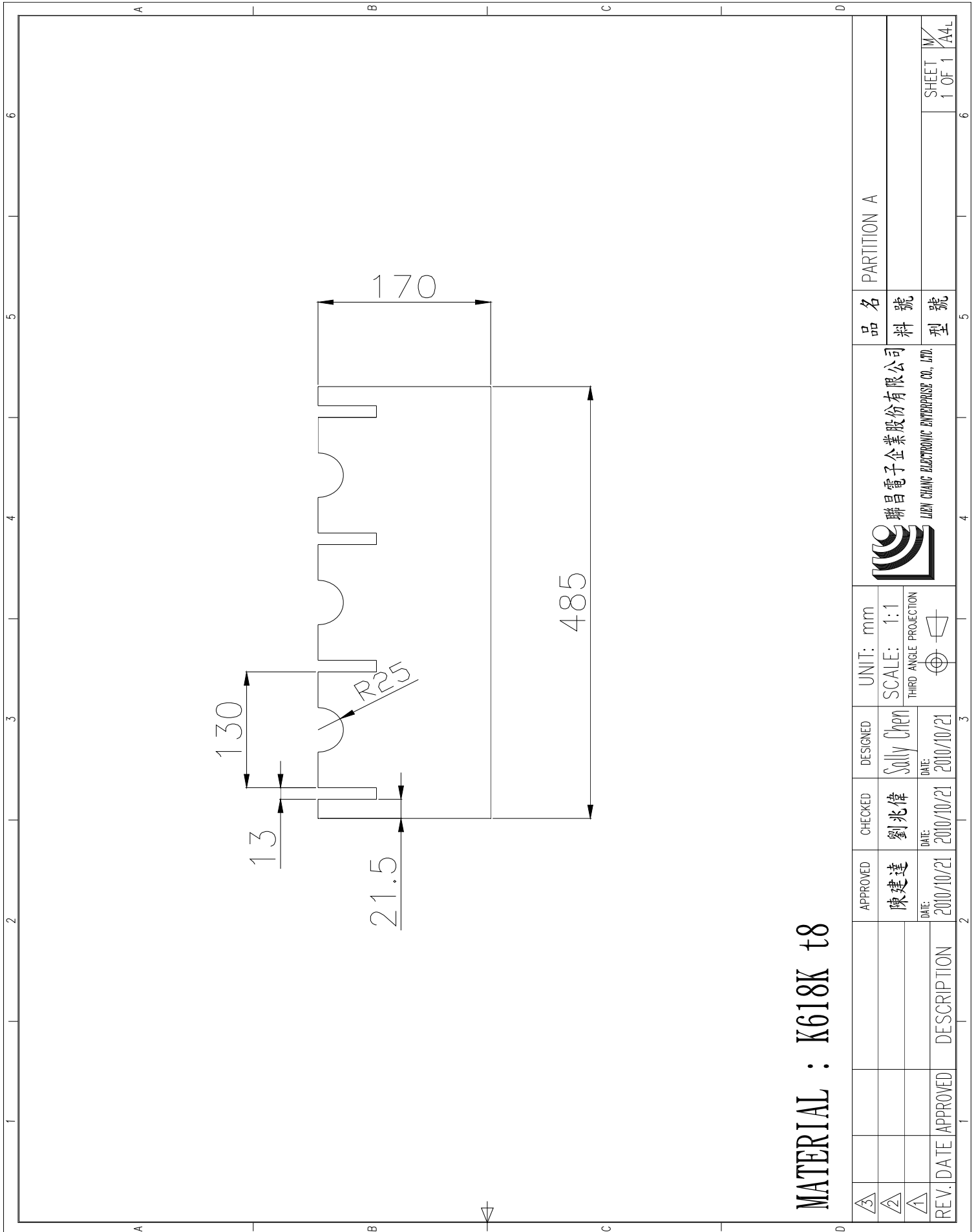

MATERIAL : K618K t8

REV. DATE	APPROVED	DESCRIPTION	PARTITION A	
	1		品名	料號
2			料號	型號
3			聯昌電子企業股份有限公司 LIEN CHANG ELECTRONIC ENTERPRISE CO., LTD.	
4	APPROVED	陳建達	UNIT: mm	
5	CHECKED	劉兆偉	SCALE: 1:1	
6	DESIGNED	Sally Chen	THIRD ANGLE PROJECTION	
		DATE: 2010/10/21		
		DATE: 2010/10/21		
		DATE: 2010/10/21		SHEET 1 / A4L
				1 OF 1

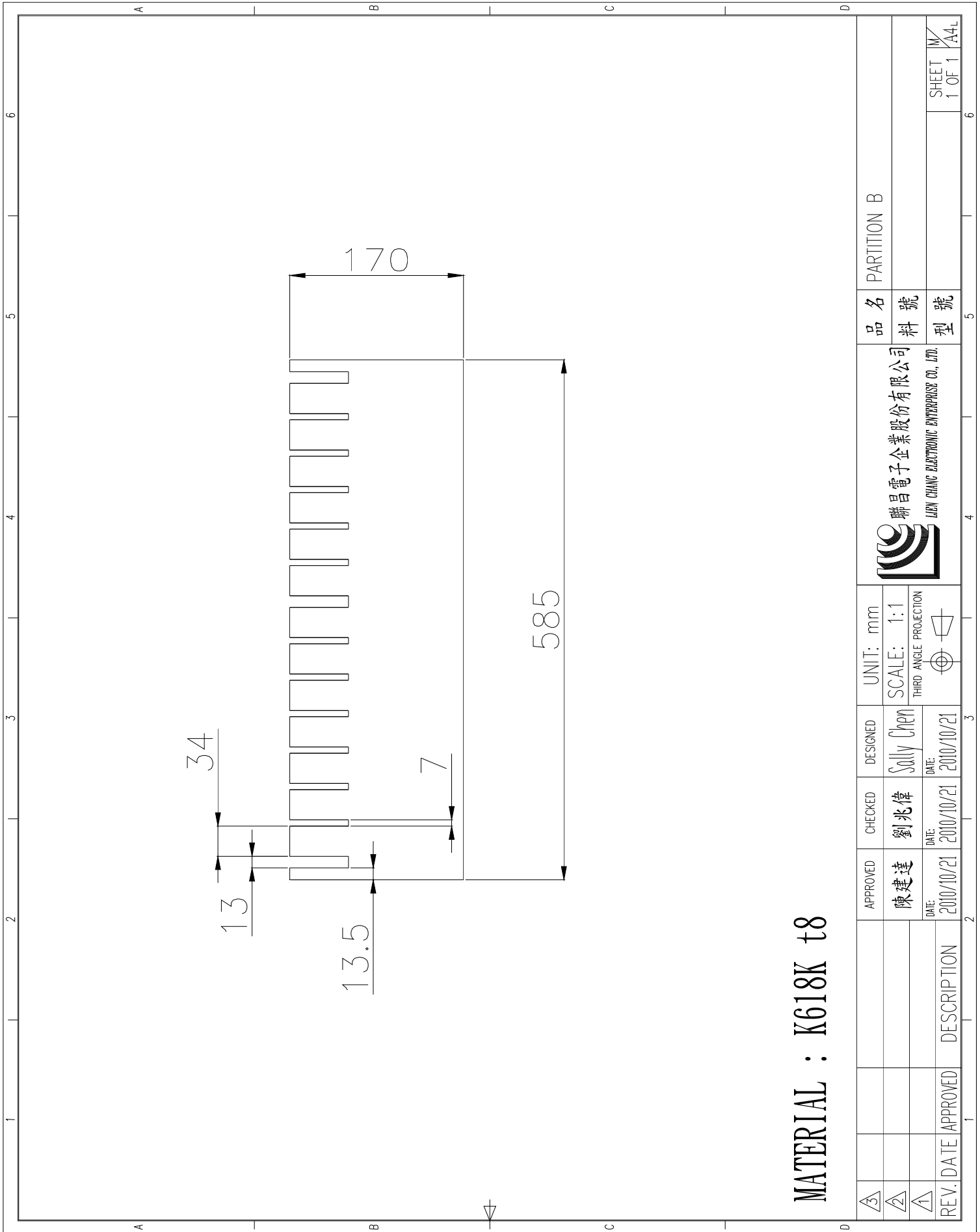

MATERIAL : K618K t8

③					UNIT: mm					品名	PARTITION B
②					SCALE: 1:1					料號	
①					THIRD ANGLE PROJECTION					型號	
REV. DATE	APPROVED	DESCRIPTION	APPROVED	DATE	CHECKED	DESIGNED	DATE	DATE	DATE		SHEET 1 OF 1
					陳建達	Sally Chen	2010/10/21	2010/10/21	2010/10/21		A4L
					劉兆偉						

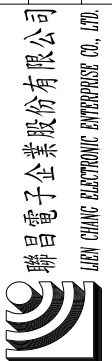



LGP32-13PL1 LCD TV Power specification

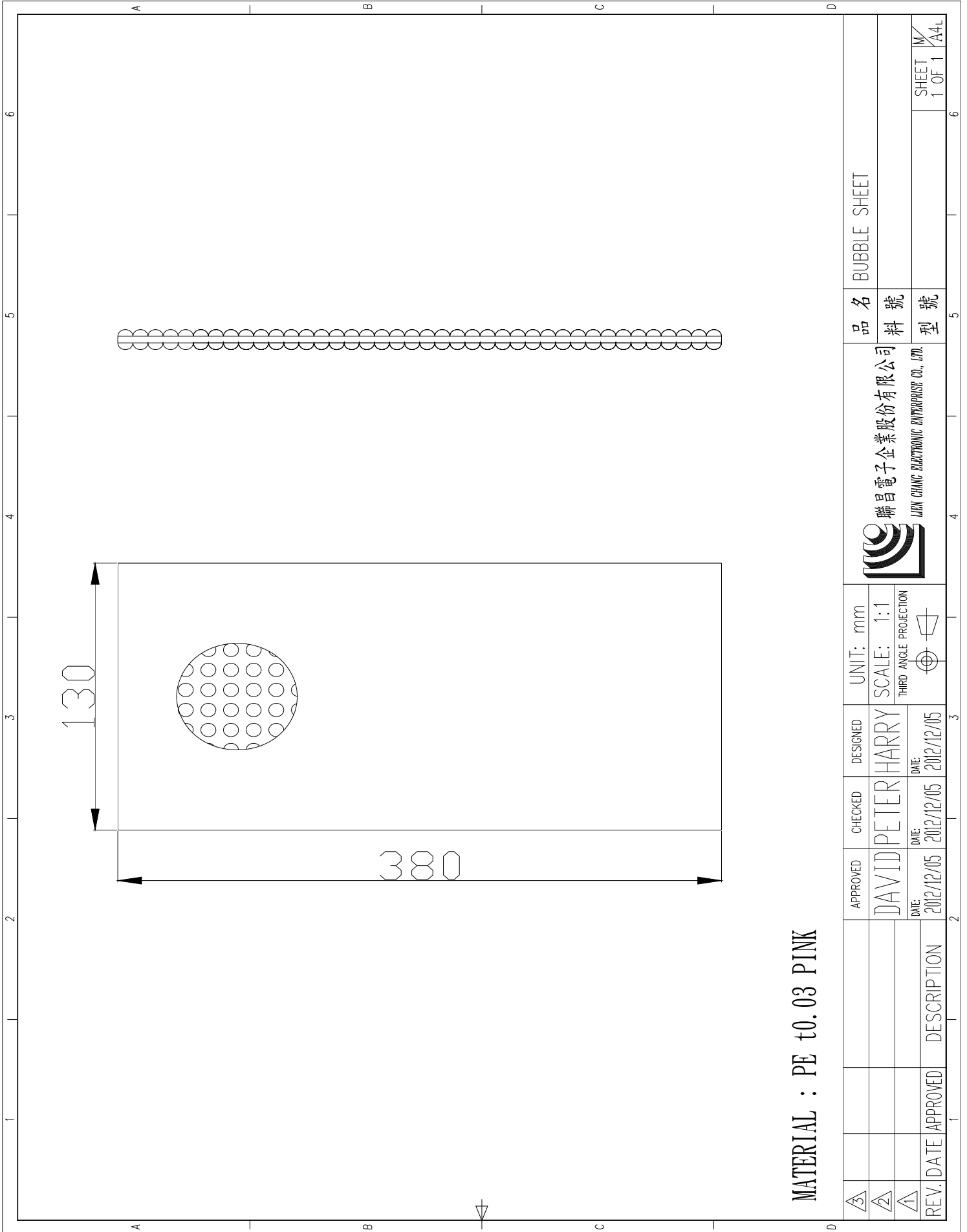

MATERIAL : PE ± 0.03 PINK

△3	APPROVED	CHECKED	DESIGNED	UNIT: mm	 聯昌電子企業股份有限公司 LIEN CHANG ELECTRONIC ENTERPRISE CO., LTD.	品名	BUBBLE SHEET
△2	DAVID	PETER	HARRY	SCALE: 1:1		料號	
△1	DATE: 2012/12/05	DATE: 2012/12/05	DATE: 2012/12/05	THIRD ANGLE PROJECTION		型號	
REV. DATE	APPROVED	DESCRIPTION	DATE			SHEET	1 OF 1
						AA-L	1



Bar-Code Label Drawing



LGP32-13PL1 LCD TV Power specification

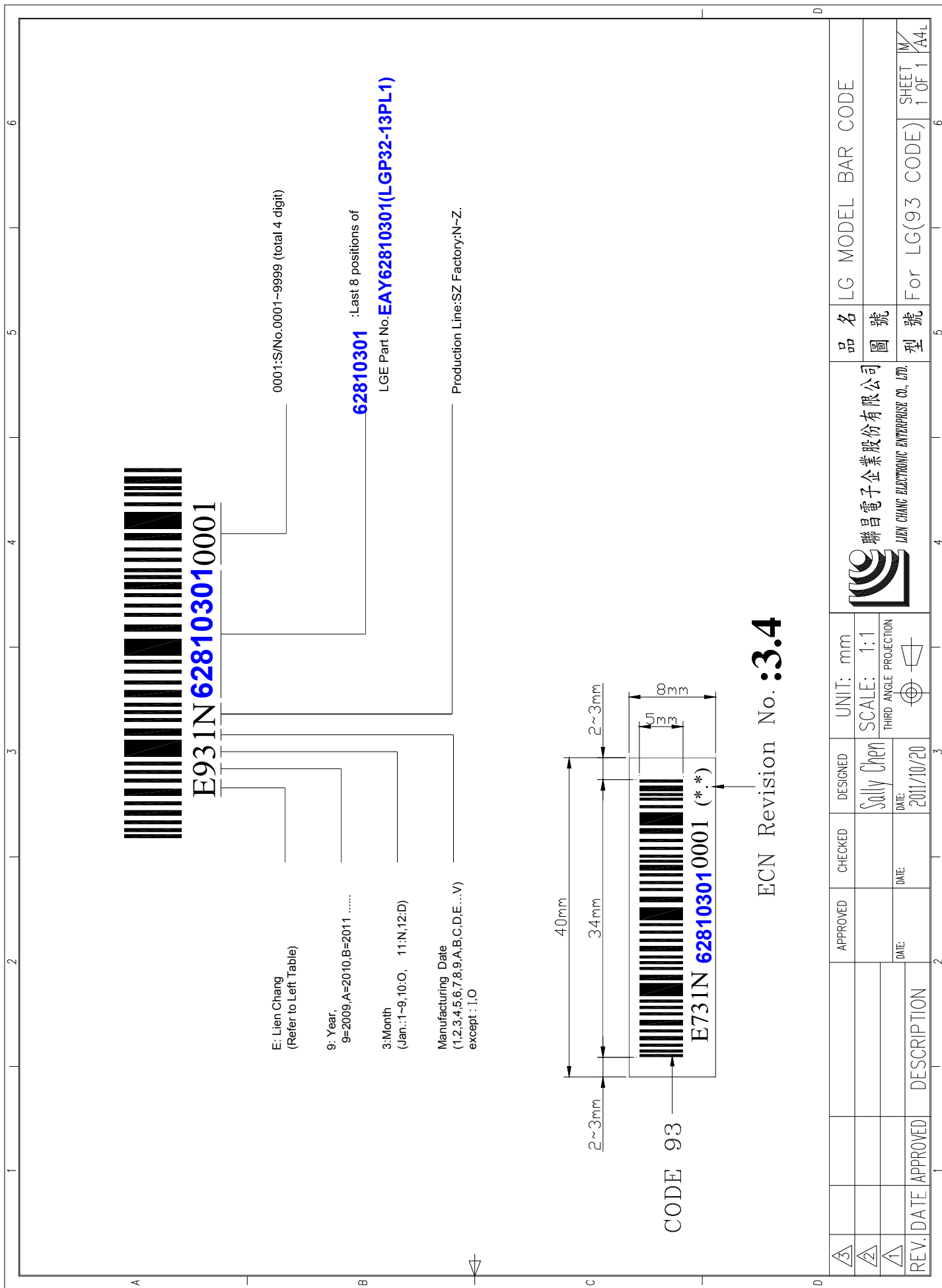

ECN Revision No. : 3.4

③		APPROVED	CHECKED	DESIGNED	UNIT: mm	品名	LG MODEL BAR CODE
②				Sally Chen	SCALE: 1:1	圖號	
①				DATE: 2011/10/20	THIRD ANGLE PROJECTION	型號	For LG(93 CODE)
REV. DATE	APPROVED	DESCRIPTION				圖號	SHEET 1 OF 1
						型號	A4L





Labeling Point



LABELING POINT

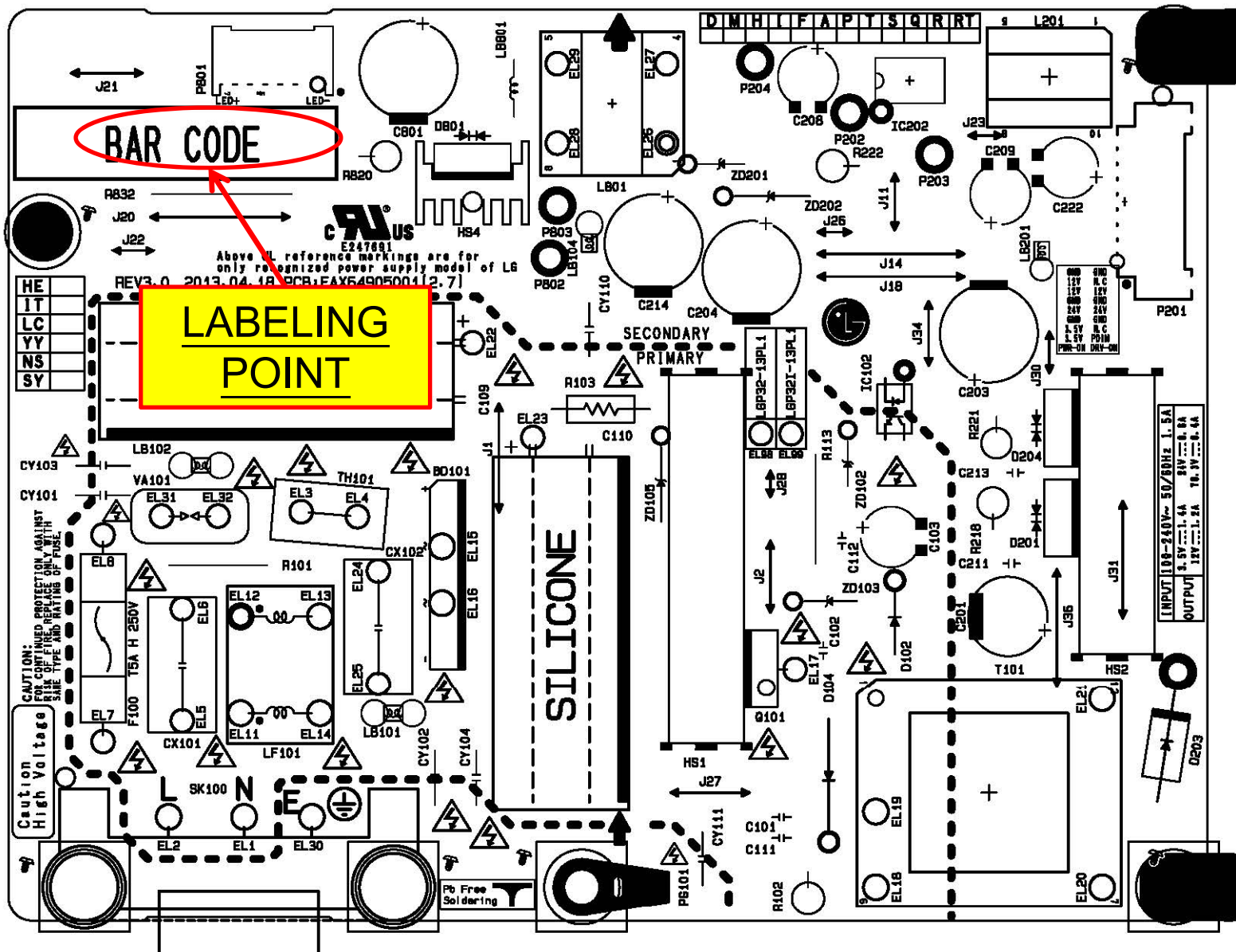



Workmanship Point



Silicone Bonding Point (●)

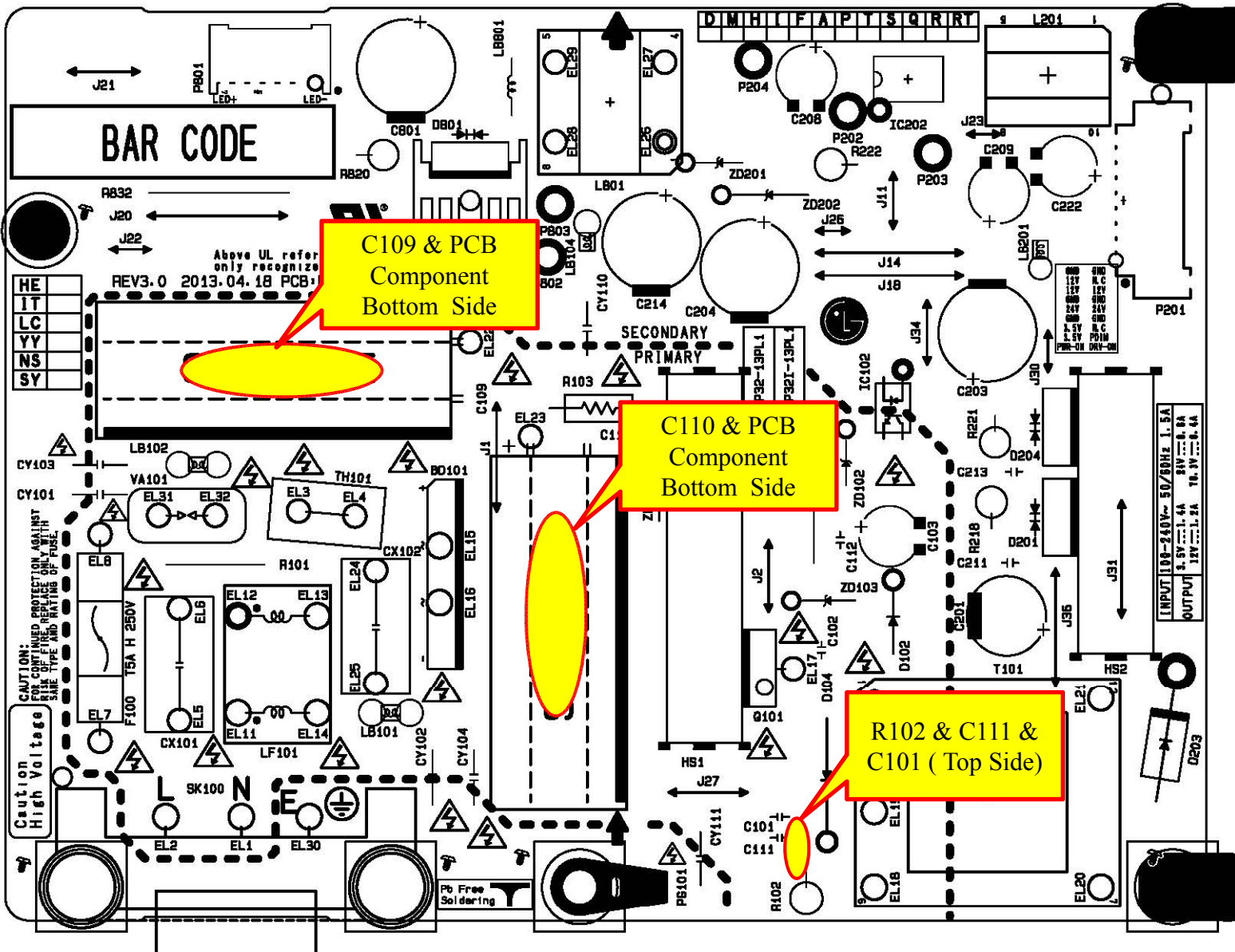











Manufacturing Process

4M QC Flow Chart

Process no.	QC Flow	Process name	Work content	Mag. Frequency	4M				
					Man(사람)	Machine(장비)	Material(재료)	Method(방법)	
1		Purchasing	Raw material purchase	Every P/O	Ping Lang	PC/ FAX/TEL	/	1. Part/No. Part Name, Spec., Q'ty, Delivery. 2. Suppliers' Magt..	Production management procedure BOM
2		Warehouse	Receive material	Every accept datasheet	Jincheng Guo	Balance Couter	/	1. Check the material box's layer. 2. Check P/No., Spec., Part name, Q'ty, Validity-period.	Incoming receiving procedure Products protection procedure
3		IQC	Incoming material inspection	MIL-STD-105E(II) AQL=0.25	David Zhang	Diode tester LCR meter Hi-pot equipment solder oven	Raw material	1. Check the Brand,P/NO, Spec.Q'ty,Validity-period, Lot No. 2. Check the appearance.	Incoming inspection procedure
4		Eyelet	PCBA eyelet	100% transfer shift change model ECN one time/2 hrs	Yuxing Tang	Eyelet M/C	Eyelet	1. Check the program of M/C 2. Check parts of BOM 3. Check lead angle:20° ~40°	1.AI first article inspection records 2.Part date code check (SEB3R24)
5		Jump Wire	PCBA Jump wire insertion	100% transfer shift change model ECN one time/2 hrs	Yuxing Tang	Jump Wire M/C	Jump Wire	1.Check the program of M/C 2.Check parts of BOM 3.Check lead angle:15° ~30° 4.Check lead lenth:1.2~1.8mm	1.AI first article inspection records 2.Part date code check (SEB3R24)
6		Axial	Axial parts auto insertion	100% transfer shift change model ECN one time/2 hrs	Yuxing Tang	Axial M/C	Axial parts	1.Check the program of M/C 2.Check parts of BOM 3.Check lead angle:15° ~30° 4.Check lead lenth:1.2~1.8mm	1.AI first article inspection records 2.Part date code check (SEB3R24)
7		Radial	Radial parts auto insertion	100% transfer shift change model ECN one time/2 hrs	Yuxing Tang	Radial M/C barcode scanner	Radial parts	1.Check the program of M/C 2.Check parts of BOM 3.Check lead angle:15° ~45° 4.Check lead lenth:1.2~1.8mm	1.AI first article inspection records 2.Part date code check(SEB3R24) 3.MES system
8		QA inspection	Sampling check	transfer shift change model ECN one time/2 hrs	Caselin Sun	magnifier LCR meter	/	1. check parts 2. Checking the PCBA 3. Checking the Quality of SMD-process	1. QA inspection form in SMT area (SEB1R34) 2. SMD capacitor measure in SMT area (SEP5R02) 3. Push-pull force data for SMT part (SEP5R01)
9		Apply red glue	Apply red glue on pcb	100% transfer shift change model ECN one time/2 hrs	Yuxing Tang	Apply gule machine	red glue	1. Progarm Editing 2. Checking the Progarm File 3. "Red-glue" store-condition: 5~10℃ /6months.	1.Store temp. of Tin paste / red gule (SEB8R02) 2.Take out/off records of Tin paste and red gule (SDM5P04) 4. process check form in SMT area (SEB3R28)
10		SMT mounting	SMD mounted on PCB	100% transfer shift change model ECN one time/2 hrs	Yuxing Tang	Yamaha Mounting machine	SMD parts	1. Progarm Editing 2. Checking the Progarm File 3. Material's checking	1.Part station in SMT area 2.Bom list
11		Visual inspection	check parts	100% transfer shift change model ECN one time/2 hrs	Yuxing Tang	nipper magnifier	/	1. "FAI"-checking & "Sample"-checking 2. Check the Part (Missing; inverse-insertion; damaged...)	1.Inspection form in SMT area (SEB3R28) 2. QA first samples check in SMT area (SEB1R33)

12		Reflow	PCBA reflow	100% transfer shift change model ECN one time/2 hrs	Yuxing Tang	profile measure requisition reflow	/	Control the temperature of "Reflow"-M/C.	1. Profile of reflow 2. Temp. control records of SMT (SEM9R04)
13		SMT inspection	check appearance	100% transfer shift change model ECN one time/2 hrs	Yuxing Tang	nipper magnifier barcode scanner	/	1. Checking the PCB with magnify 2. Checing the Quality of SMD-process	1. Self-inspection in SMT area (SEB1R36) 2. Check form in SMT 3.MES system
14		QA inspection	Sampling check	transfer shift change model ECN one time/2 hrs	Caselin Sun	magnifier LCR meter Push-pull meter	/	1. Every 2hrs, testing the capacity of "SMD-Capacitor" 2. Every 2hrs, testing the "bonding"- strength 3. Checking the PCB with magnify 4. Checking the Quality of SMD-process	1. QA inspection form in SMT area (SEB1R34) 2. SMD capacitor measure in SMT area (SEP5R02) 3. Push-pull force data for SMT part (SEP5R01)
15		component prepare	processing material	100% transfer shift change model ECN one time/2 hrs	Yuxing Tang	processing jig	prepared material	Sample Checking	1.Self-inspection 2.check datasheet for component prepare
16		MI	Manual insert material	100% transfer shift change model ECN one time/2 hrs	Yuxing Tang	NG box tray fixture barcode scanner	common parts	1. Checking the brand、P/N0、Spec.、 Name、Q'ty、Lot No.、 2. Checking the quality of MI	1.Self-inspection 2. Check form of part date code 2. check form of PCBA in process
17		 Double wave solder	soldering	100% transfer shift change model ECN one time/2 hrs	Yuxing Tang	DIP TEST equipment auto wave-solder	solder bar flux	1.Pre-heat: 350℃+/-20℃。 2.Soldering-M/C : 255℃~260℃。 3.Flux : 0.80+/-0.02g/cm3, Soldering Speed : 1.20 ~ 1.60m/Min.	1. Monthly maintain form of wave solder (SDR1R23) 2.Daily/weekly maintain form of wave solder (SDR1R22)
18		PCBA inspection	check appearance	100% transfer shift change model ECN one time/2 hrs	Yuxing Tang	magnifier	/	1. Materials' checking 2. Soldering-"Q" Checking 3. Checking the quality of Soldering surface	1.Daily report of AI/INVERTER QC (SEB3R21) 2. Inspection form of PCBA in process (SEB3R19)
19		AOI inspection	automatic optical inspection	100% transfer shift change model ECN one time/2 hrs	Yuxing Tang	AOI M/C	/	1. Checking the Test-program 2.Checking the quality of Soldering surface	1. AOI daily test report (SEB3R27) 2.Inspection form of PCBA in process (SEB3R19)
20		Touch up	manual soldering	100% transfer shift change model ECN one time/2 hrs	Yuxing Tang	IRon-soder	solder wire	Repair the "Poor-soldering" point (including cold-soldering, warp-soldering, solder-short)	1.Self-inspection 2. Inspection form of PCBA in process (SEB3R19)
21		ICT	ICT test	100% transfer shift change model ECN one time/2 hrs	Yuxing Tang	ICT test M/C	/	1. Checking the Test-program 2. Checking the Part's Spec.	1. ICT daily test report (SEB3R27) 2.Inspection form of PCBA in process (SEB3R19)
22		 HI-POT	safety test	100% transfer shift change model ECN one time/2 hrs	Xian Xu	HI-POT test M/C barcode Scanner	/	1.check HI-POT test condition meet the SPEC 2. .For ok products, scan and flow to the next station. If It is NG, stick NG label and put into NG box	1. Inspection form (SEB3R23) 2. Equipment adjust before production (SDS1R03) 3.Inspection form of finished products (SEB3R19) 4.MES system

23		Initial test	first function test	100% transfer shift change model ECN one time/2 hrs	Yuxing Tang	DC load AC power source test jig FLUKE-45 barcode Scanner	/	1.check test condition meet the SPEC 2.For ok products, scan and flow to the next station. If It is NG, stick NG label and put into NG box	1. Check data form (SEB3R23) 2.equipment adjust (SDS S1R03) 3.MES system
24		apply glue	Apply RTV bond	100% transfer shift change model ECN one time/2 hrs	Yuxing Tang	apply glue M/C	RTV bond	1. Check the P/N and Spec of silicone 2.Check the glue quantity which locates on the right place 3. Check if there is miss of applying glue	1.Self-inspection 2. Inspection form of products in process
25		PCBA sampling check	sampling check appearance	100% transfer shift change model ECN one time/2 hrs	Caselin Sun	magnifier	/	1. Material's checking 2. Checking the soldering-quality 3. Checking the quality of PCB-print	1.PCBA inspection form (SEB1R26) 2.PCBA rejection form (SEB1R30)
26		CTP Aging	burn in	100% transfer shift change model ECN one time/2 hrs	Xian Xu	Power source aging tools aging load	/	1.Aging Load:meet the SPEC. 2.aging time : 2hrs. Temp : 45℃+/-5℃。	1.records of AI/INVERTER aging(SDR9R19) 2.Aging input check form (SDR9D20)
27		CTP Final test (ATE)	Final function test	100% transfer shift change model ECN one time/2 hrs	Xian Xu	ATE barcode Scanner	/	1.check ATE test condition meet the SPEC 2. For ok products, scan and flow to the next station. If It is NG, stick NG label and put into NG box	1.Daily visual form(SEB3R21) 2. Inspection form of PCBA in process (SEB3R19) 3. Adjust equipment before production(SDS1R03) 4.MES system
28		Visual inspection	check appearance	100% transfer shift change model ECN one time/2 hrs	Xian Xu	magnifier	/	1. Check if the part was damaged and the other fails 2. Check if there was miss of applying gule 3. Do marking on the good products and flow out 4. Stick the NG label on the NG product and put into the box, at the same time, record the related information	1. Daily visual inspection form (SEB3R21) 2.Inspection form of PCBA in process(SEB3R19) LIPS/INVERTER Final test records of finished products in process(SEB3R31)
29		100% inspection	check appearance	100% transfer shift change model ECN one time/2 hrs	Xian Xu	barcode Scanner	/	1.Carefully check the solder status, for example: empty solder, wrap solder, cold solder, PCB 2. Check the PIN is damaged in connector	1. Visual daily form(SEB3R21) 2. LIPS/INVERTER inspection form(SEB3R31) 3.MES system
30		Package	pack PCBA into box	100% transfer shift change model one time/2 hrs	Xian Xu	Tape M/C Pen	box bubble sheet	1. Check the P/N, Model name, date, label, carton 2. Put the products in the right place and stick label	1.Records of products traking s/n (SEB3R22) 2. Records of tracing the Inverter S/N Inspection finished products form (SEB3R19)
31		OQC	Sampling finished products	MIL-STD-105E(II) AQL=0.25	Caselin Sun	DC load AC/DC SOURCE FLUKE-45 barcode Scanner	/	1. Check the part, soldering status, part damage, and so on 2. Measure the dimension of the product 3. Test the electrical parameter 4. Stick the NG label on the NG product and put into the NG box, at the same open the reject note 5. NG product must be rework	1.Finished products inspection procedure 2.Adjust equipment before production (SDS1R03) 3.outgoing inspection data of finished products (SEB1R28) 4.MES system
32		Warehouse	Store product	Every store datasheet	Jincheng Guo	Trailer barcode Scanner	/	1. Check P/N, Model, Quantity 2. Check the heigh of stock and carton 3. cCheck the QA pass seal	1.Finished product store procedure 2.Store datasheet 3.MES system

incoming operate inspect store



Appendix List

No.	Contents	Total Page number
1	Power Check list	12 Page
2	Warranty letter	3 page



Appendix 1.

POWER CHECK LIST



LGP32-13PL1 LCD TV Power specification

Revision History		Rev	DATE	REMARK
1	Format changed PCB Check Sheet Ver1.9 to Power Check Sheet Ver1.0	1.0	2011.06.02	
2	1. Essentiality Marking items – Add No. 14 Input Standard Mark for 2 pin in Bare PCB 2. Compoment –Add No. 13 If you use choke coil lying, You can use after appoint test item for poor prevention.	1.1	2012.05.23	
3	PCB Pattern Space – Add No. 9 Add 8.5mm (thickness of GND Pattern) or Insert of Jump Wire For use Together (IT and TV)	1.2	2012.10.30	



Details Check Item		RESULT		REMARK
▶ Components LOCATION NO.		OK	NG	
1	Power Primary section circuit Location No. : 100 series (Including Multi primary)	OK		
2	Power Secondary section circuit Location No. : 200 series (Including Stand by & Multi Secondary)	OK		
3	Inverter Primary section circuit Location No. : 300 series	-		
4	Inverter Secondary section (Including F/B,OVP circuit) circuit Location No. : 400 series	-		
5	Stand by Primary section circuit Location No. : 500 series	-		
6	PFC section circuit Location No. : 600 series	-		
7	MICOM section circuit Location No. : 700 series	-		
8	LCD : LED Driver section circuit Location No. : 800 series	OK		This content only applies to LCD
9	PDP : Stand by Primary and Secondary section circuit Location No. : 300 series	-		This content only applies to PDP
10	PDP : Va Secondary section circuit Location No. : 500 series	-		This content only applies to PDP
11	PDP : Vs Secondary section circuit Location No. : 900 series	-		This content only applies to PDP
12	PDP : Vs,Va Primary section circuit Location No. : 800 series	-		This content only applies to PDP
13	CTV : Power Block section circuit Location No. : 800 series	-		This content only applies to CTV



LGP32-13PL1 LCD TV Power specification

Details Check Item		RESULT		REMARK
▶ Components LOCATION NO.		OK	NG	
14	Resistor circuit Location No. : From beginning to R***.	OK		
15	Capacitor circuit Location No. : From beginning to C***.	OK		
16	Diode circuit Location No. : From beginning to D***.	OK		
17	Zener Diode circuit Location No. : From beginning to ZD***.	OK		
18	Coil circuit Location No. : From beginning to L***.(Including PFC section)	OK		
19	Transformer circuit Location No. : From beginning to T***.(Including Drive Trans)	OK		
20	Bead circuit Location No. : From beginning to LB***.	OK		
21	Fuse circuit Location No. : From beginning to F***.	OK		
22	TR/FET/Thyristor circuit Location No. : From beginning to Q***.	OK		
23	Varistor circuit Location No. : From beginning to VA***.	OK		
24	Volume Resistor circuit Location No. : From beginning to VR***.	-		Variable Resistance
25	Jumper circuit Location No. : From beginning to J***.	OK		
26	H/S circuit Location No. : From beginning to HS***.	OK		
27	IC circuit Location No. : From beginning to IC***.	OK		2007.04.16 DDC Standard
28	Connector wafer / Ass'y(Board in type) circuit Location No.: From beginning to P***.	OK		
29	Eyelet circuit Location No. : From beginning to EL***.	OK		
30	Gripper circuit Location No. : From beginning to G***.	-		
31	Holder circuit Location No. : From beginning to HD***.	-		
32	Thermistor circuit Location No. : From beginning to TH***.	OK		



Details Check Item		RESULT		REMARK
▶ Components LOCATION NO.		OK	NG	
33	Metal Ground circuit Location No. : From beginning to PG***.	OK		
34	Line Filter circuit Location No. : From beginning to L***.	OK		
35	AC Socket(Inlet) circuit Location No. : From beginning to SK***. (Including AC Power supply wafer for Docking)	OK		2007.04.16 DDC Standard
36	Photo Coupler circuit Location No. : From beginning to IC***.	OK		2007.04.16 DDC Standard
37	Relay circuit Location No. : From beginning to RL***.	-		
38	Y-Capacitor circuit Location No. : From beginning to CY***.	OK		
39	X-Capacitor circuit Location No. : From beginning to CX***.	OK		
40	Fuseble Resistor Location No. : From beginning to R***.	-		
▶ PCB Pattern Space (Keep a Safety distance)		OK	NG	
1	Primary ↔ Secondary(GND,Y-Cap,Photo Coupler) : A space(Gap) of at least 6.5mm. (But, Working Voltage is more than 350V, Comply with the space of the safety request.)	OK		Refer to the Attached File NOTE 0  Creepage
2	Primary(L,N) ↔ Safety GND : A space of at least 3mm. (But, In the case of Two Pin, A space of at least 6mm)	OK		
3	Live ↔ Neutral : A space of at least 3mm.	OK		
4	Primary↔Secondary components (Clearance) : A space of at least 6mm. (if space is below 6mm, it must add insulation sheet)	OK		
5	(Power Primary section) Main Current loop is made more than 3mm on Pattern thickness(width). (B/Diode ↔ Primary Main cap : Very important)	OK		
6	Don't pass small signal line under PFC Coil. DC is no problem.	-		
7	When It Connects Main GND (AC smooth Capacitor Cap. GND) to IC GND, separate pattern after consideration for pattern impedance.	OK		
8	In the case of Stand by IC of the Dip type, secure safety distance between pin of the high voltage and pin of the low voltage. (Only, use N.A or Bare Pin near Drain pin)	-		



LGP32-13PL1 LCD TV Power specification

Details Check Item		RESULT		REMARK
▶ PCB Pattern Space (Keep a Safety distance)		OK	NG	
9	Satisfy Continuity TEST of the grounding about FG GND (40A / 2Minute) → Add 8.5mm (thickness of GND Pattern) or Insert of Jump Wire For use Together (IT and TV) (But, If EMI Issue occur, we don't apply.)	OK		



LGP32-13PL1 LCD TV Power specification

Details Check Item		RESULT		REMARK
▶ Component		OK	NG	
1	When surge test, Between Primary and Secondary space have to gap of at least 6mm . { Distinguish between safety GND and secondary GND (Use Y-cap with insulation) , need Space, need Insulation Sheet }	OK		※ 3 Pin : A space of at least 3mm 2 Pin : A space of at least 6mm
2	Beside Primary smooth cap. component is separated a heating component over 3mm. (clearance)	OK		
3	Primary smooth cap. component is separate as below - Upper area : over 1mm - Bottom area : over 5mm (Only, Vertical type Capacitor) (Note 1)	OK		
4	Don't pass the pattern under 3mm area on primary smooth cap. (Only top side pattern of Epoxy)	OK		
5	If use short-height core, you must use insulation tape. (To add the space distance with PCB)	OK		This content only applies to Insulation Trans of first, secondary
6	In case of trans, use Barrier of at least 7mm(6.4 + 3.2) by 300V (Standard). (Wire's Tube can be use for reduce Barrier tape height) Safety Gr. is sure to check the item. (Note 0)	OK		
7	In case of AC Inlet, Screw of Yellow-Green wire is use more than 3.5Φ. * if it don't use Y/G wire. When only PCB pattern use, it must have pass the 200A test. * Safety GND is role of independence GND. UL Test Request If it use only Pattern, Safety is certainly check.	OK		
8	The component is pushed by force, The Clearance is need to at least 6mm between Primary and Secondary components. Don't touch the core by another parts.	OK		
9	When use Box type Capacitor, apply to Forming type with RTV Bond. (Including X-capacitor) (Only Sony PDP Model)	-		

NOTE 0



Creepage

NOTE 1



CAPACITOR



Details Check Item		RESULT		REMARK
▶ Component		OK	NG	
10	All of parts should be separated more than 2mm around CORE (Including all Trans type). •In case of Inducted Voltage 1kV (peak to peak) should be separated more than 4mm. (based on 1000:1 Probe)	OK		
11	Between Inverter Trans and Metal Frame(shield) is separated more than 4mm. (if it is difficult, surely add Insulation sheet)	-		
12	Output wafer of the secondary use add type of a fixed pin. (But, except for the wafer of LPB using for Micom Debugging)	OK		
13	If you use choke coil lying, You can use after appoint test item for poor prevention (Note 2)	OK		



NOTE 2



Choke coil



LGP32-13PL1 LCD TV Power specification

Details Check Item		RESULT		REMARK
▶ Essentiality Marking items		OK	NG	
1	AC Socket, AC inlet Wafer must be marked "L"/"N". Also docking Type is marked.(QA Request), : Top & Bottom side (Note 3-2)	OK		※ Fuse is located on Live
2	When Safety GND is separated from Chassis, Worker should be located by confirmation. (Note 2) • PCB top & bottom side is all marking, Please Check the attached file in detail Content. And, Certainly receive the final confirm by safety Gr.	OK		※ But, except for 2 pin
3	Fuse rating(Voltage,T, Current,H), caution(Safety title), UL Mark should be input. Ex) T5A H 250V * Caution: Don't change the words based on UL's sentence. (For ~ , Replace ~)	OK		
4	Fuse must locate very ease finding scope. (Fuse Marking is the same)	OK		
5	High Voltage warning mark have to be input. - Inverter Output : Only LIPS. - Primary section Metal.(H/Sink), High Voltage opened location. (Fuse) : All Model	OK		
6	To mark the Input/Output Voltage &, Current Spec. (Note 3)	OK		
7	Classify Primary and Secondary section have to be marked for separation of Area. (Top side/Bottom side) - Power side Primary & Secondary - to mark the Only the Inverter output.	OK		
8	Each component circuit No. have to be shown	OK		
9	Don't overlap the Bottom circuit No. in solder pattern/ Components shape etc.	OK		
10	Draw PCB marking, Considering Dead Space of Tool structure. Add Metal area mark for PCB fixing.	OK		
11	Check CTI spec in PCB specification Check Marking in Bare PCB - Marking : CTI 600 (More than 600V)	OK		
12	Input Caution Mark in a Circuit diagram (CCL standards) 	OK		
13	Input Screw Mark in Bare PCB 	OK		
14	Input Standard Mark for 2 pin in Bare PCB 	-		※ Only, apply to 2 pin

NOTE 2



Safety GND 규정

NOTE 3



Input/Output

NOTE 3-2



B/D-in socket



LGP32-13PL1 LCD TV Power specification

Details Check Item		RESULT		REMARK
▶ EMI		OK	NG	
1	When Lightning Surge is L/N Test, Varistor must use more than 14Φ 620V.	OK		
2	Lightning Surge to L/G & G/N : 3KV over Y-Cap. (Use Y1 Class)	OK		
3	In case of lightning surge, only Fuse Dead is OK, only. (Countermeasure : Protect to arcing. Varistor is closely located Fuse.)	OK		
4	GND Arcing pattern Slit size is 1.2mm. Both ends distance of the Arcing Pattern is 3.0mm by safety role. (Between L and N)	OK		
5	Conducted Emission Test Condition : 110Vac/220Vac & 50Hz/60Hz TV Model : GND Connect / No connect VIVID/STANDARD, HDMI/ANTENNA	OK		
▶ INVERTER (only LIPS)		OK	NG	
1	Do use Ballaster capacitor.			
2	When small signal AC pattern pass around to 4mm from Inverter Trans, it is no problem after confirmed OVP/OLP and etc Worst condition. (Including Feed Back Line) [For the reduce of inverter noise from AC Input, Power FET's Heat sink's form can change for using shield between AC input and Inverter Trans. (CE restriction item) – Consider design]	-		
3	The Lead of high voltage ceramic CAP applied at inverter output part must keep insulation distance or be applied RTV bonding, even though the article force is applied.	-		
4	Check size around Gripper or Eyelet of Inverter Trans. -Size of the copper around Gripper or Eyelet : More than 5.5mm -Pattern Size around Gripper or Eyelet : More than 6mm (But, only apply LIPS of more than 32Inch)	-		
5	Inverter wafer use horizontality type.	-		



Details Check Item		RESULT		REMARK
		OK	NG	
▶ ETC				
1	Don't use CAN Type Fuse.	OK		
2	Housing`s Maker of Connector what Main Board /Power Board (LIPS) have to be same with Wafer Maker. If they are differ, You have to check the spec./Drawing or request the component test to IQC(in case Board in type connector, Also Terminal type must be checked	OK		
3	Don't use Litz Wire.	OK		USTC
4	Apply to PFC Bypass Diode. (Note 4)	-		See attached file(Bypass)
5	When use Relay, apply to Fusing Resistor. (Note 5) (But, when Fusing Resister don't apply, Check Relay Open Test – Check PL Condition)	-		See attached file(Relay)
6	Use of High Ripple & Low Impedance type's rectification CAP at primary control IC VCC.	OK		
7	Don't use RN Type (Metal Film Type) Resistor over 100kohm.	OK		In June 26 th 08, We have had problem about this at MP for LGEND.
8	When apply TO-220, TO-3P type FET, Diode, IC, Lead length is shorted because of cutting after forming. So, Lead length and pitch must have checked by Heat-sink, Approval sheet on PDM, Actual Component. (Take conference previously with LGEAZ, LGEND about this issue, LGEND wants forming type in all TO-220, TO-3P type's components)	OK		In March 08 for LGEAZ CKD PQ event , We have history responded to the emergency issues
9	Check the Lead length of PCB bottom side, when use H/sink, wafer and other component at special type model which manages Lead length.	OK		
10	In this case, Component in Critical Component List. Check Marking on component.	OK		
11	If discharge resistance is used model sold to the Japanese market, Use Resister of the Dip Type certified standard. (Only, Use model sold to the Japanese market)	OK		

NOTE 4



Bypass-Diode

NOTE 5`



Relay



LGP32-13PL1 LCD TV Power specification

Details Check Item		RESULT		REMARK
		OK	NG	
▶ Attachment				
1	 <p>PL check List PL Safety Check List Ver3.7</p>	OK		



Appendix 2

Warranty letter



Non-use certificate

Description	For approval / <u>For mass production</u>	Submitting date	2012 . 7 . 31
-------------	---	-----------------	---------------

Cooperating suppliers

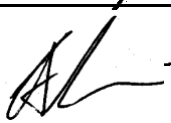
Company name	Lien Chang Electronic	Approval	Person in charge	Head of department
Contact	Tel: (886-2) 22035100	Name	Alan Wang	Alan Wang
e-Mail	alanwang@lienchang.com.tw	Signature		

LGE Part No.	EAY62810301	Part production date	filling the sheet in case of mass production
Maker Part No.	OPVP-0177	Production plant	filling the sheet in case of mass production
Part name	LGP32-13PL1		

This is to certify that materials used and contained in the products and components that we supply to your company, meet the standards of the checked items listed below.

———— below ————

We meet the standards of LG Electronics for six major substances (Pb, Cd, Cr⁶⁺, Hg, PBBs, PBDEs) as designated by RoHS for control.

* Records are requested if they are parts to be actually installed on the PCB (Printed Circuit Board)

Soldering Type: Flow Reflow (Requirement : 250°C /10 sec)

1. Maximum heat-resisting temperature : 260_°C 2. Time within actual Peak time : 10_ sec.

Pb-Free Soldering (all solder cream, Bar, Wires included) is available to apply.

Note.

1. All the contents written on these documents must be created on the basis of facts, and cooperating suppliers must submit the data immediately whenever LG Electronics requests.
2. In the case that these documents are used for approval purposes, cooperating suppliers must submit the sample on the request. For the purpose of mass production, it must be submitted at the time of delivering the first product.





Control list of environment-related substances

Description	Substances	Contained		Remark
		YES	NO	
Level A- I	Lead(Pb) and its compounds		✓	
	Cadmium(Cd) and its compounds		✓	
	Mercury(Hg) and its compounds		✓	
	Hexavalent chromium and its compounds		✓	
	Polybrominated biphenyls(PBB)		✓	
	Polybrominated diphenylethers(PBDE)		✓	
Level A- II	Polychlorinated biphenyls (PCB)		✓	
	Polychlorinated naphthalenes (PCN)		✓	
	Polychlorinated terphenyls (PCT)		✓	
	Short-chain Chlorinated paraffins (SCCP)		✓	
	Asbestos and its compounds		✓	
	Ozone Depleting Substances		✓	
	Azo compounds		✓	
	Nickel(Ni) and its compounds		✓	
	Specific Organic tin compounds		✓	
	Arsenic(As) and its compounds		✓	
	Formaldehydes		✓	
Level B	Polyvinyl chloride (PVC)		✓	
	Phthalates		✓	
	Beryllium(Be) and its compounds		✓	
	Antimony(Sb) and its compounds		✓	
	Selenium(Se) and its compounds		✓	
	Palladium amd its compounds		✓	
	Bismuth and its compounds		✓	
	Other Chlorinated flame retardants		✓	
	Other brominated flame retardants		✓	