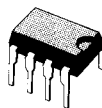

TELEPHONE INTERFACE CIRCUIT
AN AT&T PRODUCT
ADVANCE DATA

- WITHSTANDS TELEPHONE LOOP VOLTAGES TO 150 V DC AND 200 V PULSED
- OPERATES AT LOW TIP-RING VOLTAGES (typically as low as 2.7 V)
- POLARITY GUARD HAS LOW INTERNAL VOLTAGE DROPS
- MONOLITHIC SOLID-STATE CONSTRUCTION GIVES COMPETITIVE EDGE IN PHYSICAL AREA CONSERVATION AND RELIABILITY

MINIDIP

ORDER CODE : LH1028BB
DESCRIPTION

Dielectric isolation and a monolithic high-voltage DMOS technology are used to fabricate the LH1028 Telephone Interface Circuit (TIC). This integrated circuit performs the following basic functions : high-voltage dial pulse switching, protection against reversal of Tip-Ring polarity from the Central Office, and overvoltage/overcurrent protection of telephone circuits.

PIN DESCRIPTION

Pin	Symbol	Description
2	Tip	Tip Input
8	Ring	Ring Input
3	T Prime (T')	Positive Output of Polarity Guard
7	DP	Control for Internal Dial Pulse Switch
6	DP Prime (DP')	Control for Internal Dial Pulse Switch
4	R Prime (RP')	Negative Output of Polarity Guard
1,5	NC	No Connection Allowed Reserved Pins

PIN CONNECTION (top view)

Figure 1 : Functional Diagram.



ABSOLUTE MAXIMUM RATINGS

Symbol	Parameter	Value	Unit
V_{TRD}	Dialling Voltage (tip-ring) ($t_{ON} = 2 \text{ ms}$; $f = 10 \text{ Hz}$)	180	V
V_{IMP}	Pulse Voltage (tip-ring) ($t_{ON} = 2 \text{ } \mu\text{s}$; $t_{OFF} = 30 \text{ sec}$)	200	V
T_A	Ambient Operating Temperature Range	0 to 50	$^{\circ}\text{C}$
T_{stg}	Storage Temperature Range	- 40 to + 125	$^{\circ}\text{C}$
	Pin Temperature (soldering, 15 sec)	300	$^{\circ}\text{C}$
P_D	Power Dissipation (package limitation)	750	mW

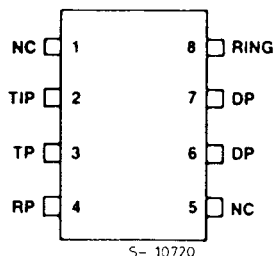
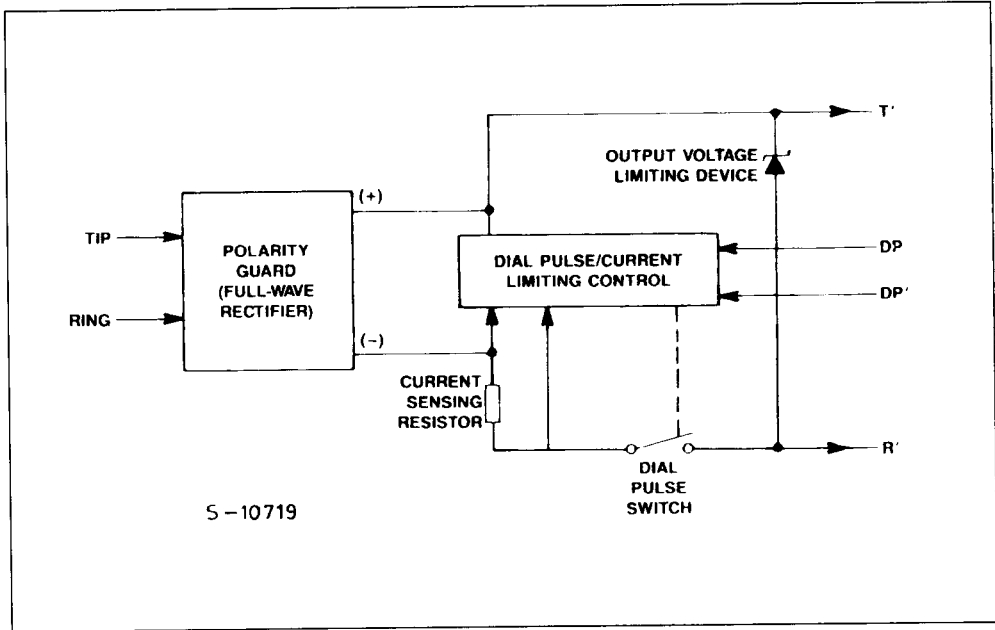
THERMAL DATA

$R_{th \text{ j-amb}}$	Thermal Resistance Junction-ambient	Max	120	$^{\circ}\text{C/W}$
------------------------	-------------------------------------	-----	-----	----------------------

ELECTRICAL CHARACTERISTICS (see figure 2)
 ($T_A = 4$ to 49 °C for min. and max. value) ($T_A = 25$ °C for typical value)

Parameter	Test Conditions	Min.	Typ.	Max.	Unit
Breakdown Voltage (tip-ring)	$V_{DP} = 2$ V ; $R_L = 1000$ Ω Increase V_{TR} until $I_{TR} = 3$ mA (see fig. 3)	155	175	–	V
Dial Pulse Control Voltage, V_{DP}	$V_{TR} = 48$ V ; $R_L = 200$ Ω $I_{DP} = 5$ μ A (see fig. 4)	–	1.7	2	
Dial Pulse Control Current	$V_{TR} = 48$ V ; $V_{DP} = 2$ V ; $R_L = 200$ Ω (see fig. 3)	–	–	20	μ A
Off-state Leakage Current	$V_{TR} = 48$ V ; $V_{DP} = 2$ V ; $R_L = 200$ Ω (see fig. 3)	–	–	400	μ A
Tip-ring Operating Voltage	Increase V_{TR} until $V_{OUT} = 1.6$ V $R = 400$ Ω $I_{RP} = -4$ mA (see fig. 4)	–	2.7	2.9	V
On-state Voltage $V_{TR} = 6$ V	$R = 235$ Ω ; $I_{RP} = -20$ mA ; $V_{DP} = 0.65$ V Measure $V_{TR} - V_{OUT}$ (see fig. 4)	–	1.05	1.3	
Output Voltage, $V_{TR} = 140$ V peak	Measure V_{OUT} peak (see fig. 5)	–	26	30	
Turn-on Time	DP Initially at +2 V (see fig. 6)	–	20	500	μ s
Turn-off Time	DP Initially shorted to DP' (see fig. 7)	–	20	500	
Current Limiting	$R_L = 40$ Ω ; $V_{DP} = 0.65$ V (see fig. 8)	155	–	–	mA

Figure 2 : Simplified Schematic Illustrating Characteristic Symbology.

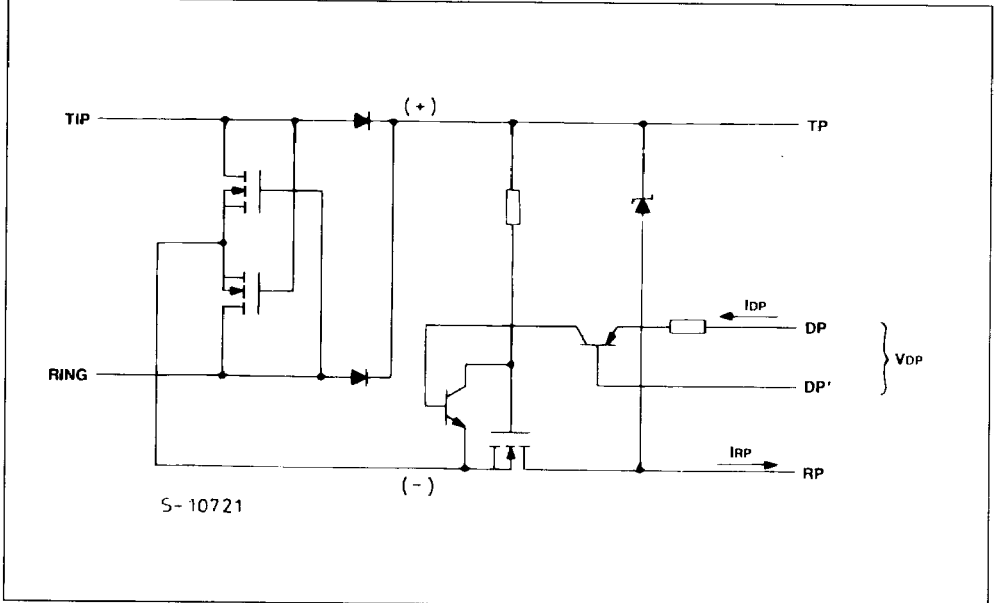

TEST CIRCUITS

Figure 3.

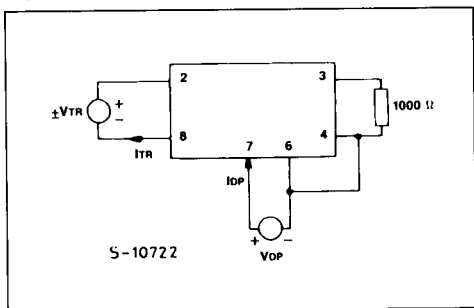

Figure 4.

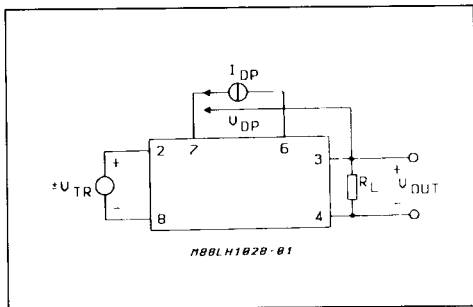
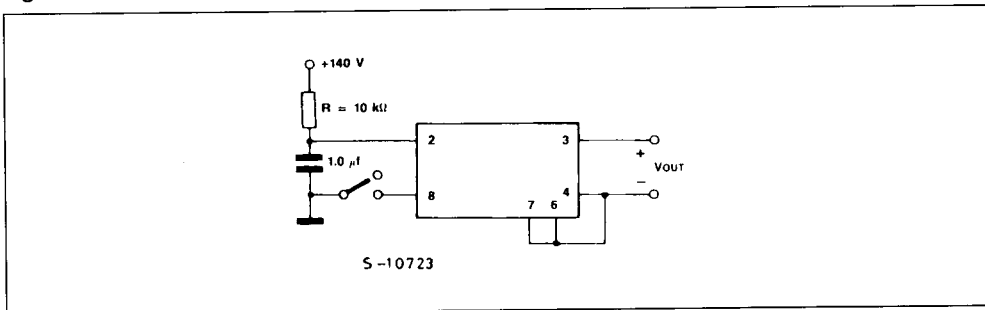

Figure 5.



CHARACTERISTIC TIMINGS

Figure 6 : Turn-on Time Test Method.

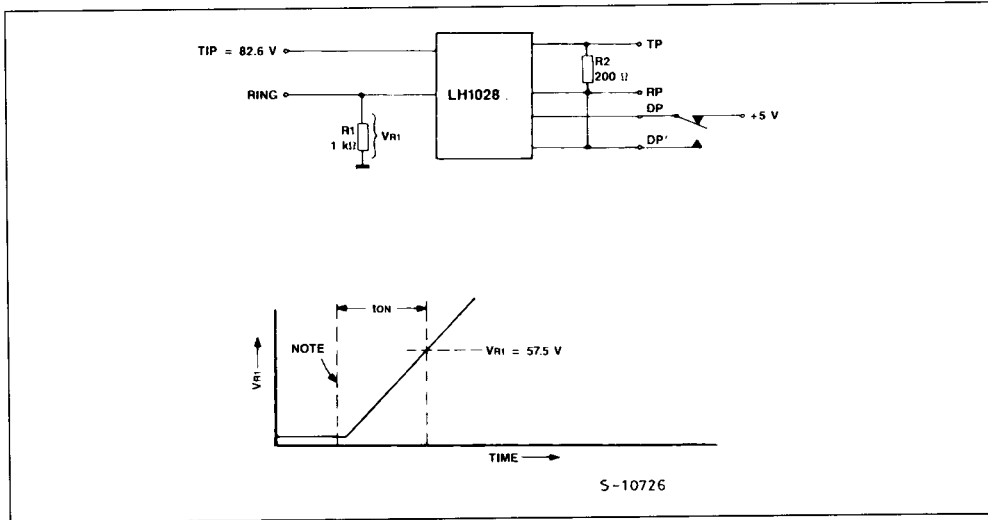

Figure 7 : Turn-off Time Test Method.

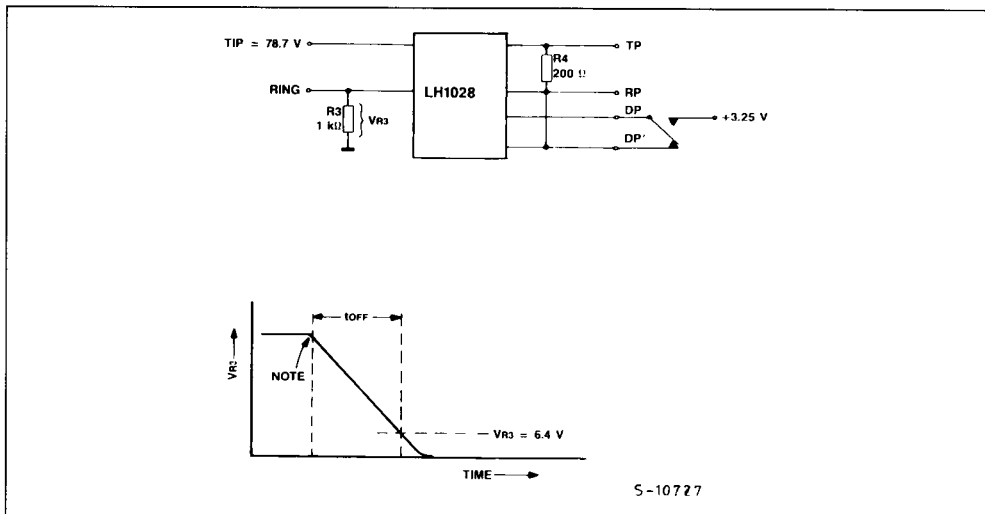
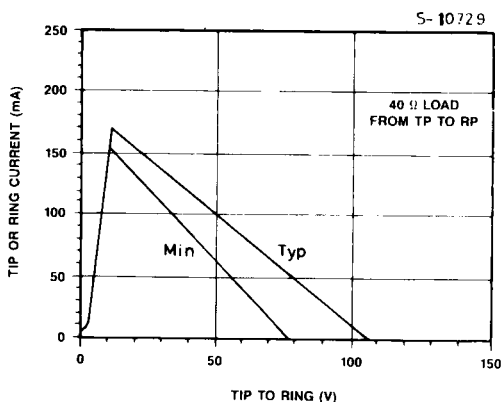

Figure 8 : Current Limiting Characteristics.



APPLICATION

The LH1028 device can be connected in the following manner to perform telephone interface functions. An overvoltage metal-oxide-varistor or other similar type of device shunts the Tip-Ring input terminal of the LH1028 TIC and limits the voltage across these terminals to less than 200 V (the maximum voltage rating of the LH1028). The output terminals of the LH1028 TIC are TPRIME (T') and

RPRIME (R'). T' and R' are the positive and negative sides of the TIC polarity guard, respectively. R' is connected to the telephone circuitry through a switch which is internal to the LH1028 TIC. This internal switch opens when a dial pulse voltage is applied between terminal DP (Dial Pulse) and DP' (Dial Pulse Prime).

Figure 9 : Typical Telephone Set Configurations.

