

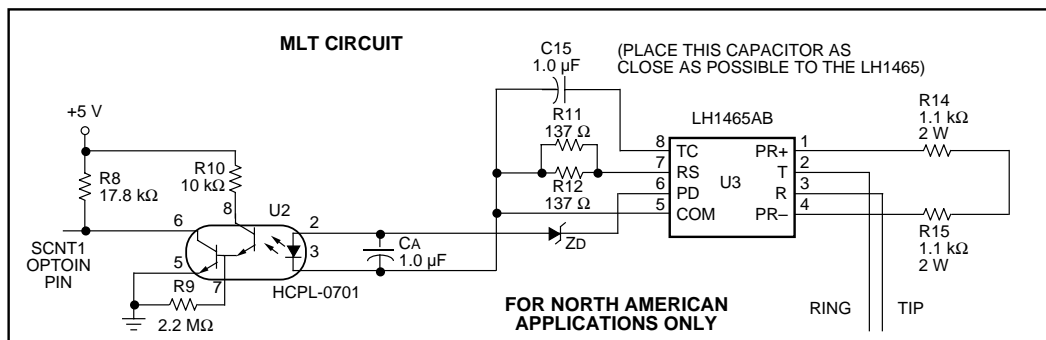

## LH1465AB/AE ISDN dc Termination IC Data Sheet Advisory

### Application Circuit

Replace Figure 11 on page 10 of the LH1465AB/AE data sheet with the figure shown below.



5-7034(C)

**Figure 1. MLT Circuit Showing New Placement of Zener Diode (Z<sub>D</sub>) and Capacitor (C<sub>A</sub>)**

In the ILOSS mode (refer to ANSI T1.601 1992, Section 6.5.2), the NT generates a scrambled, framed, 2B1Q signal such as SN1 and SN2. When the ILOSS mode is applied to circuits with the LH1465, it was observed that for some short loop lengths, the NT, once in the ILOSS mode, would not respond to further maintenance pulses until the ILOSS timer expired. It was discovered that there is some portion of the transmitted 2B1Q signal from the NT that passes through the LH1465 to the optoisolator. This causes the optoisolator to report incorrect dial pulses at its output, and thus prevent the NT from properly exiting the ILOSS mode.

To correct this situation, the dropout voltage (voltage at the Tip/Ring needed to turn on the optoisolator) of the optoisolator driver on the LH1465 is raised using the 3.6 V zener diode Z<sub>D</sub> (for example, *Motorola*\* MMSZ4685T1). Capacitor C<sub>A</sub> is a 1.0 μF ±10% tantalum chip capacitor, with a voltage rating of at least 16 V. C<sub>A</sub> is added to provide a level of filtering for the transition points (turn-on or turn-off) of the optoisolator input voltage, which increases the robustness of the circuit.

\* *Motorola* is a registered trademark of Motorola Inc.

---

For additional information, contact your Microelectronics Group Account Manager or the following:

INTERNET: <http://www.lucent.com/micro>

E-MAIL: [docmaster@micro.lucent.com](mailto:docmaster@micro.lucent.com)

N. AMERICA: Microelectronics Group, Lucent Technologies Inc., 555 Union Boulevard, Room 30L-15P-BA, Allentown, PA 18103  
**1-800-372-2447**, FAX 610-712-4106 (In CANADA: **1-800-553-2448**, FAX 610-712-4106)

ASIA PACIFIC: Microelectronics Group, Lucent Technologies Singapore Pte. Ltd., 77 Science Park Drive, #03-18 Cintech III, Singapore 118256  
**Tel. (65) 778 8833**, FAX (65) 777 7495

CHINA: Microelectronics Group, Lucent Technologies (China) Co., Ltd., A-F2, 23/F, Zao Fong Universe Building, 1800 Zhong Shan Xi Road, Shanghai 200233 P. R. China **Tel. (86) 21 6440 0468, ext. 316**, FAX (86) 21 6440 0652

JAPAN: Microelectronics Group, Lucent Technologies Japan Ltd., 7-18, Higashi-Gotanda 2-chome, Shinagawa-ku, Tokyo 141, Japan  
**Tel. (81) 3 5421 1600**, FAX (81) 3 5421 1700

EUROPE: Data Requests: MICROELECTRONICS GROUP DATALINE: **Tel. (44) 1189 324 299**, FAX (44) 1189 328 148

Technical Inquiries: GERMANY: **(49) 89 95086 0** (Munich), UNITED KINGDOM: **(44) 1344 865 900** (Bracknell),

FRANCE: **(33) 1 48 83 68 00** (Paris), SWEDEN: **(46) 8 600 7070** (Stockholm), FINLAND: **(358) 9 4354 2800** (Helsinki),

ITALY: **(39) 2 6601 1800** (Milan), SPAIN: **(34) 1 807 1441** (Madrid)

---

Lucent Technologies Inc. reserves the right to make changes to the product(s) or information contained herein without notice. No liability is assumed as a result of their use or application. No rights under any patent accompany the sale of any such product(s) or information.





## LH1465AB/AAE ISDN dc Termination IC

### Features

- ANSI U-DSL compatible
- High linearity
- MLT compatible
- SARTS compatible
- Portable test set compatible

Device Code	Package Type
LH1465AB	8-Pin, Plastic DIP
LH1465AAE	16-Pin, Plastic SOG

### Description

The LH1465 ISDN dc Termination IC is used on U-interface digital subscriber lines (U-DSL) and provides a polarity insensitive dc termination for the loop-sealing current and a recognizable signature for mechanized loop testing (MLT) systems. The LH1465 passes dc signaling information to the NT1 circuitry through a 6N139 optoisolator (or equivalent). The LH1465 IC consists of two functional blocks. The first provides the electronic inductor and silicon-controlled rectifier portion of the termination, while the second drives the LED of the 6N139 optoisolator. Inquire about the availability of tape-and-reel packaging for the 16-pin SOG (LH1465AAE).

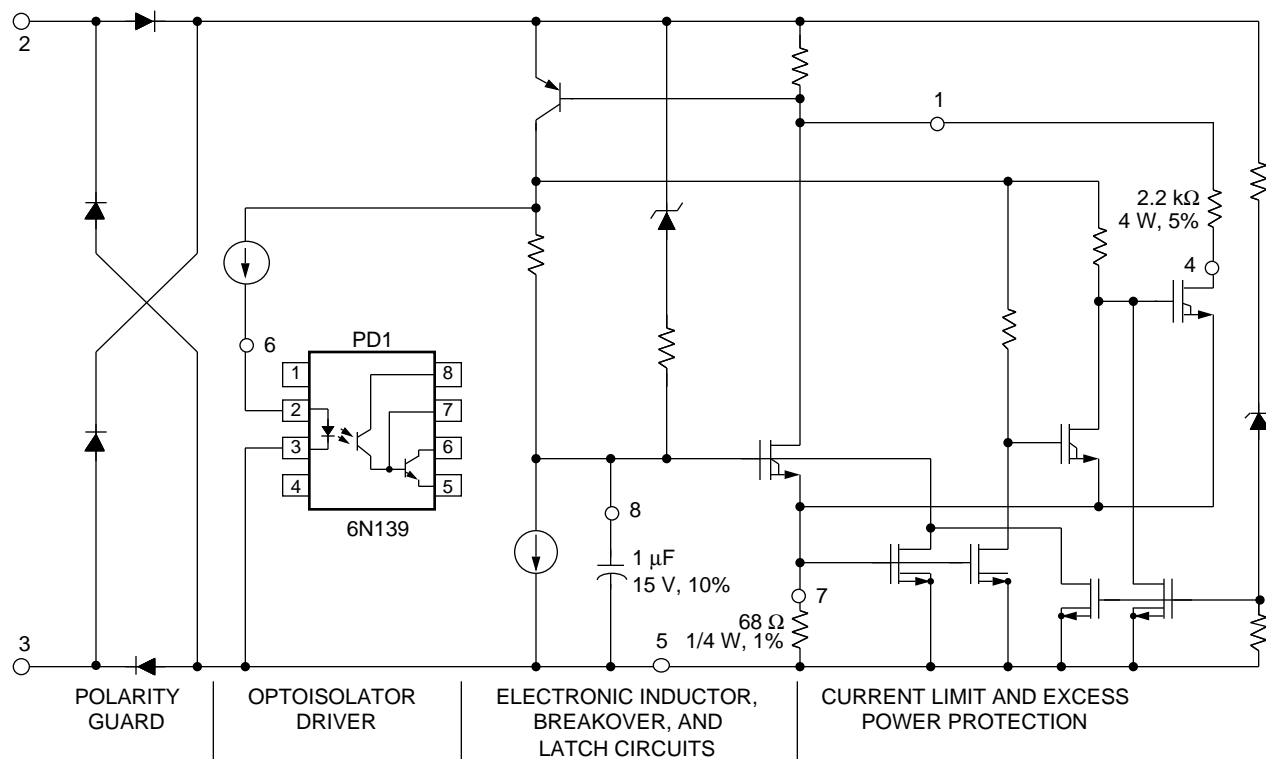

Figure 1. Functional Diagram/8-Pin DIP

## Functional Description

The LH1465 plays a dual role in the ISDN NT1: first, as an electronic inductor for a dc termination with high ac impedance; and second, as part of the dc signaling system for line testing capability. The LH1465 meets or exceeds all specifications for the ISDN NT1 dc termination as described by ANSI Standard T1.601-1991.

Use of the LH1465 requires only a few discrete components. See Figure 11 for a typical NT1 application. The LH1465 is current limited, but is not an overvoltage surge protector. A crowbar-type surge protector limiting the line voltage to less than 250 V is recommended to protect the LH1465. The surge protector must withstand the requirements in Tables 4 and 5. One such protector is the Teccor\* Inc., P2000AA61 SIDACTOR\*.

The LH1465 has a polarity guard so that the device gives the same characteristics whether the NT1 TIP or RING terminal is connected to the battery voltage. TIP and RING are connected directly to the LH1465AB terminals 2 and 3 and to the LH1465AAE terminals 4 and 5.

The dc T to R I-V characteristics of the LH1465 are shown in Figures 2 and 3. As battery voltage is applied to the loop, the LH1465 conducts current only when the voltage across the LH1465 exceeds about 35 V. With 35 V or more applied to the LH1465A, the device conducts about 150  $\mu$ A of current for about 20 ms and then turns on and goes into the ON state. The LH1465 will remain in the ON state for as long as the loop current exceeds 0.5 mA.

The LH1465 has a turn-on and turn-off timing circuit that ensures that the LH1465 will: a) not turn on if a voltage above 43.5 V is applied for less than 3 ms; and b) not turn off if the loop current is interrupted for less than 3 ms.

Current for the LED of the optocoupler flows when the current in the LH1465 is greater than 1 mA. However, the LH1465 is guaranteed to turn on if a voltage above 43.5 V is applied for more than 50 ms, and turn off if

1 mA loop current is interrupted for more than 100 ms. See Figures 6, 7, and 8 of this document or Table F1 in Appendix F of ANSI Standard T1.601-1991.

Current for the LED is interrupted when loop current is interrupted. The current in the ON state is determined by the battery voltage and loop resistance. Should the loop resistance be negligible and/or applied voltage excessively large, the LH1465 will limit the loop current to less than 60 mA. While in current limit, the LH1465 shunts the 2.2 k $\Omega$ , 4 W power resistor R2 across itself to protect against excessive thermal heating.

In the event that fault voltages exceeding 100 V are impressed upon TIP and RING, the LH1465 will shut off and go into a standby mode where very little current flows. When the fault voltage is removed, the LH1465 goes back into its normal ON-state operation.

## Pin Descriptions

DIP	SOG	Symbol	Name/Function
1	1	PR+	Protection resistor positive side
2	4	T	Tip side of the loop
3	5	R	Ring side of the loop
4	8	PR-	Protection resistor negative side
5	9	COM	Common
6	12	PD	Photodiode (LED input current)
7	13	RS	Current-limit resistor
8	16	TC	Timing capacitor
	2, 3	NC	No connection
	6, 7	NC	No connection
	10, 11	NC	No connection
	14, 15	NC	No connection

\* Teccor is a trademark and SIDACTOR is a registered trademark of Teccor, Inc.

## Absolute Maximum Ratings At 25 °C

Stresses in excess of the absolute maximum ratings can cause permanent damage to the device. These are absolute stress ratings only. Functional operation of the device is not implied at these or any other conditions in excess of those indicated in the operations sections of the data sheet. Exposure to absolute maximum ratings for extended periods can adversely affect device reliability.

Parameter	Symbol	Min	Typ	Max	Unit
Ambient Operating Temperature	T <sub>A</sub>	-40	—	85	°C
Storage Temperature	T <sub>stg</sub>	-40	—	125	°C
Power Dissipation	P <sub>D</sub>	—	—	1	W
Pin Soldering Temperature (t = 15 s)	—	—	—	300	°C
Maximum Voltage (T/R, R/T)*	—	—	—	300	V <sub>dc</sub>

\* If the SOG package is used, it is recommended to place a drop of RTV (room temperature vulcanizing) compound on the tip and ring pins (pins 3 and 4). This will guard against the possibility of arcing between the pins (which are 0.030 in. apart) under worst-case dust and oil board buildup conditions.

## Electrical Characteristics T<sub>A</sub> = 25 °C

Minimum and maximum values are testing requirements. Typical values are characteristics of the device and are the result of engineering evaluations. Typical values are for information purposes only and are not part of the testing requirements.

**Table 1. dc Specifications, Normal Operation** (See Figures 2 and 3.)

Parameter	Symbol	Test Condition	Min	Typ	Max	Unit
Activate/Nonactivate Voltage	V <sub>AN</sub>	—	30.0	37.0	39.0	V
Breakover Current	I <sub>BO</sub>	—	—	0.5	1.0	mA
dc Voltage Drop Active State	V <sub>ON</sub>	1 mA ≤ I <sub>SL</sub> ≤ 20 mA	—	13.75	15	V
dc Leakage Current	I <sub>LKG</sub>	V <sub>OFF</sub> = 20 V	—	0.001	5	μA
Hold/Release Current Active State	I <sub>H/R</sub>	—	0.1	0.5	1.0	mA
Minimum ON Current	I <sub>MIN1</sub>	V <sub>ON</sub> < 54 V	20	35	—	mA
Minimum ON Current	I <sub>MIN2</sub>	54 V ≤ V <sub>ON</sub> ≤ 100 V for 2 s Source Resistance: 200 Ω to 4 kΩ	9.0	45	—	mA
Minimum ON Current	I <sub>MIN3</sub>	V <sub>ON</sub> > 100 V	0	0.2	—	mA
Maximum ON Current	I <sub>MAX1</sub>	V <sub>ON</sub> ≤ 70 V	—	—	70	mA
Maximum ON Current	I <sub>MAX2</sub>	V <sub>ON</sub> > 70 V	—	—	$\frac{V_{ON}}{1 \text{ k}\Omega}$	mA
Optocoupler LED Current Active State (6N139)	I <sub>LED</sub>	—	0.2	0.3	10	mA

**Table 2. ac Specifications, Normal Operation**

Parameter	Symbol	Test Condition	Min	Typ	Max	Unit
ac Impedance	Z <sub>MT</sub>	200 Hz to 50 kHz (See Figure 4.)	10	50	—	kΩ
Linearity Distortion	D <sub>1</sub>	f = 200 Hz to 40 kHz, I <sub>SL</sub> = 1 mA to 20 mA V <sub>APP</sub> ≤ 10.5 V <sub>PP</sub> (See Figures 4 and 5.)	75	84	—	dB
Linearity Distortion	D <sub>2</sub>	f = 200 Hz to 40 kHz, I <sub>SL</sub> = 1 mA to 20 mA V <sub>APP</sub> ≤ 12 V <sub>PP</sub> (See Figures 4 and 5.)	50	80	—	dB

**Electrical Characteristics**  $T_A = 25\text{ }^\circ\text{C}$  (continued)**Table 3. Transition Specifications, Normal Operation** (See Figure 6.)

Parameter	Symbol	Test Condition	Min	Typ	Max	Unit
Activate Time	t1	See Figure 6.	3.0	22	50	ms
Release Time	t2	See Figure 7.	3.0	10	100	ms

**Testing Characteristics****Table 4. Abnormal Conditions Class 1 (Survivable; No Device Damage)**

Assume carbon block primary protectors at demarcation point. Assume crowbar protection across the LH1465 device with peak voltages limited to 250 V.

Test Name	Parameter	Value
Obsolete Sealing Current	Voltage Duty Cycle	72 V Continuous
MLT Testing	Voltage Source Impedance Duration Duty Cycle	190 V 200 $\Omega$ <1 s 25%
Inadvertent Ringing	ac Voltage dc Voltage Source Impedance Duty Cycle	150 Vrms 52 V 200 $\Omega$ 33% over 6 s
Lightning:*		
L1 Normal	Peak Voltage Rise Time vs. Fall Time Peak Current Repetitions (each polarity)	600 V 10 x 1000 $\mu\text{s}$ 200 A 4
L2 Normal	Peak Voltage Rise Time vs. Fall Time Peak Current Repetitions (each polarity)	1000 V 10 x 560 $\mu\text{s}$ 200 A 2
L3 Normal	Peak Voltage Rise Time vs. Fall Time Peak Current Repetitions (each polarity)	1000 V 10 x 160 $\mu\text{s}$ 200 A 2

\* Voltages are applied from the first lead of the pair to ground with the second lead of the pair grounded, from the second lead of the pair to ground with the first lead grounded, and from the pair connected together to ground.

**Table 5. Abnormal Conditions Class 2 (Fail Safe; No Fire)**

Assume carbon block primary protectors at demarcation point. Assume crowbar protection across the LH1465 device with peak voltages limited to 250 V.

Test Name	Parameter	Value
ac Power Cross: Case 1	Voltage Source Impedance Duration	300 Vrms—600 Vrms $\leq 3\ \Omega$ 5 s
Case 2	Voltage Source Current Limit Duration	0 Vrms—600 Vrms 0 A—2 A 30 minutes
Case 3	Voltage Source Current Limit Duration	300 Vrms—600 Vrms 2 A—6 A 5 s

## Component Specifications

**Table 6. LED Trigger Specifications During MLT Signaling**

Parameter	Symbol	Test Condition	Min	Typ	Max	Unit
Applied ac Voltage	—	—	60	—	62	V <sub>PEAK</sub>
Applied ac Frequency	—	—	2	—	3	Hz
Number of Half Cycles Applied	—	—	6	—	10	—
Total Loop Resistance	—	—	900	—	4500	Ω
Required LED Response at the Output of the 6N139:						
Number of Pulses per Half Cycle Applied	—	—	—	1	—	—
Pulse Width (opto ON)	PWL	(See Figure 9.)	10	—	—	ms
Pulse Width (opto OFF)	PWH	(See Figure 9.)	10	—	—	ms

**Table 7. LED Trigger Specifications During Dial Test Set Signaling** (See Figure 10.)

Parameter	Symbol	Test Condition	Min	Typ	Max	Unit
Applied dc Battery Voltage	—	—	-43.5	—	-56	V <sub>dc</sub>
Frequency (pulses per second)	—	—	4	—	8	—
Percent Break	—	—	40	—	60	%
Number of Pulses	—	—	6	—	10	—
Total Loop Resistance	—	—	200	—	4000	Ω
Required LED Response at the Output of the 6N139:						
Number of Pulses per Make/Break Applied	—	—	—	1	—	—
Pulse Width (opto ON)	PWL	(See Figure 9.)	10	—	—	ms
Pulse Width (opto OFF)	PWH	(See Figure 9.)	10	—	—	ms

**Table 8. Discrete Component Specification** (See Figures 10 and 11.)

Component		Value	Tol. (%)	Type
Function	Name			
Sets Current Limit	R1	68 Ω	±1	1/4 W
Provides Shunt Path During Current Limit	R2	2.2 kΩ	±5	4 W
Sets Activate Deactivate Time Constant: Provides Gate-source Voltage Stabilization for Electronic Inductor	C1*	1 μF	±10	—
Optoisolator Provides Interface to Maintenance Mode Circuit	PD1	—	—	6N139

\* Insulation resistance of this part must be >2 GΩ.

Characteristic Curves

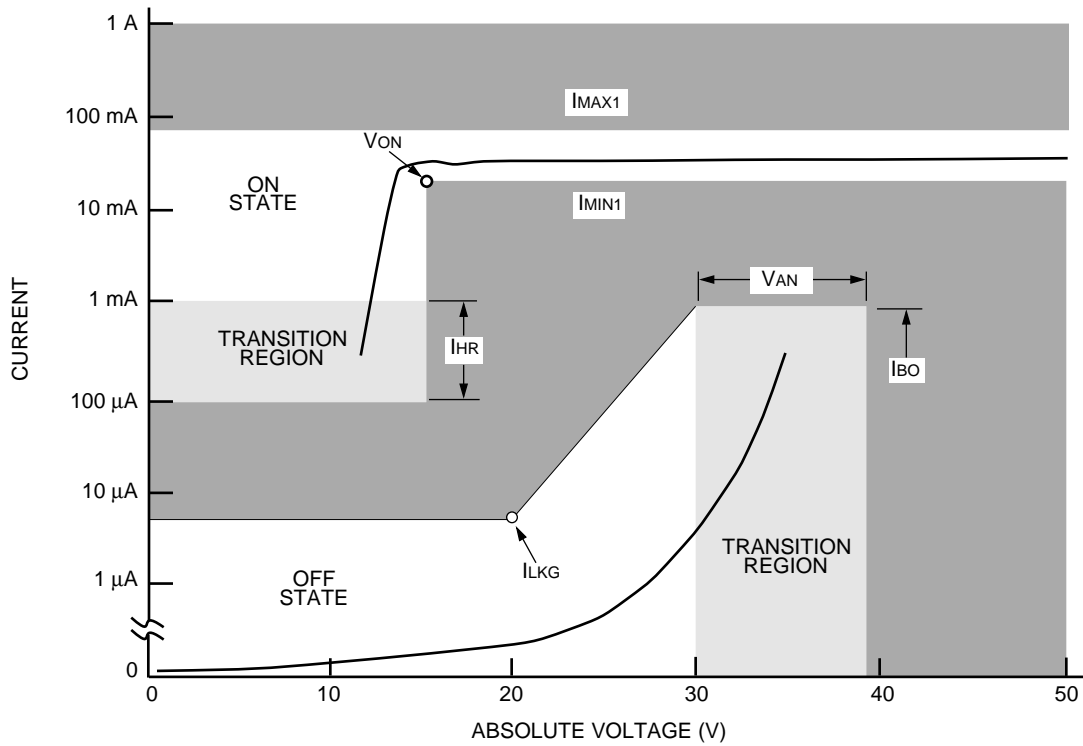

12-1937

Figure 2. I-V Requirement Template, 0 V to 50 V

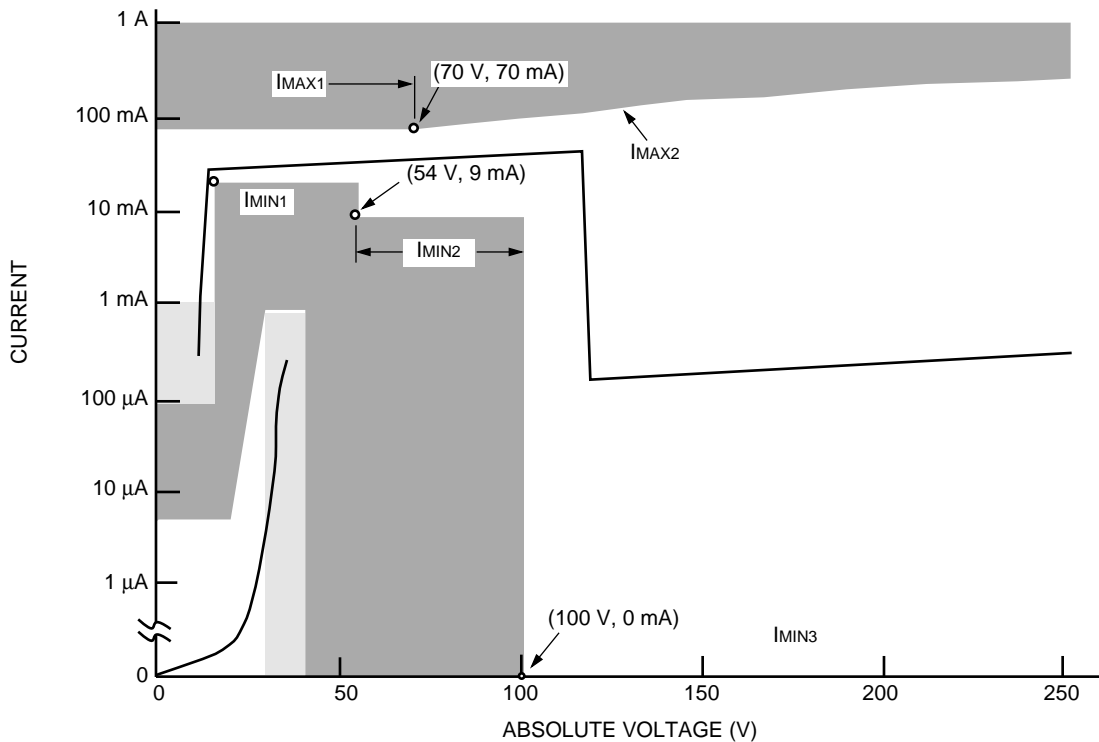

12-1938

Figure 3. I-V Requirement Template, 0 V to 250 V



Test Circuits

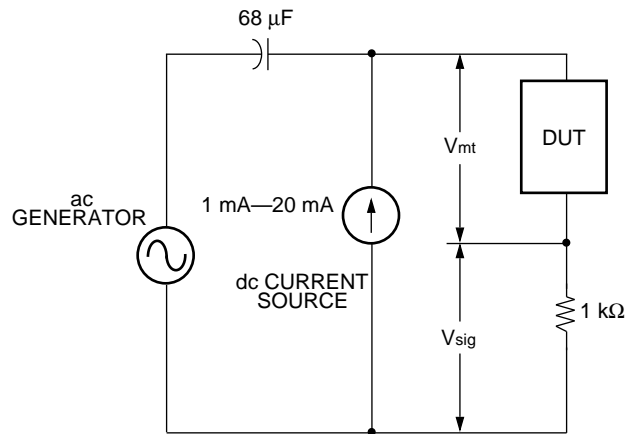

$$|Z_{mt}| = \frac{1000 \times V_{mt}}{V_{sig}}$$

$$\text{Linearity} = 20 \log \left[ \frac{V_{mt}}{V_{sig} - 2\text{nd Harm.}} \right] + 20 \log \left[ \frac{1000}{67.5} \right]$$

12-1939

Figure 4. Test Circuit for ac Impedance and Linearity

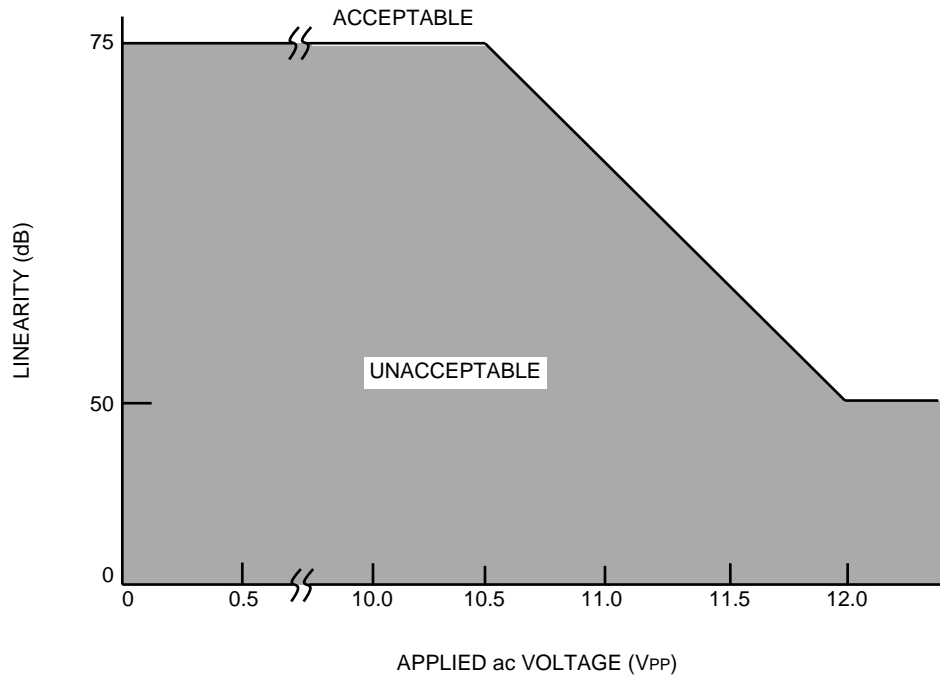

12-1940

Figure 5. Linearity Requirement Template

Test Circuits (continued)

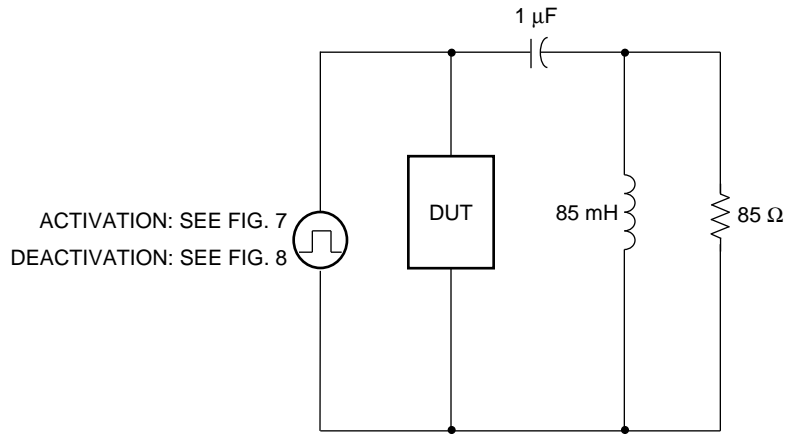

12-1941

Figure 6. Test Circuit for Activate and Deactivate Times

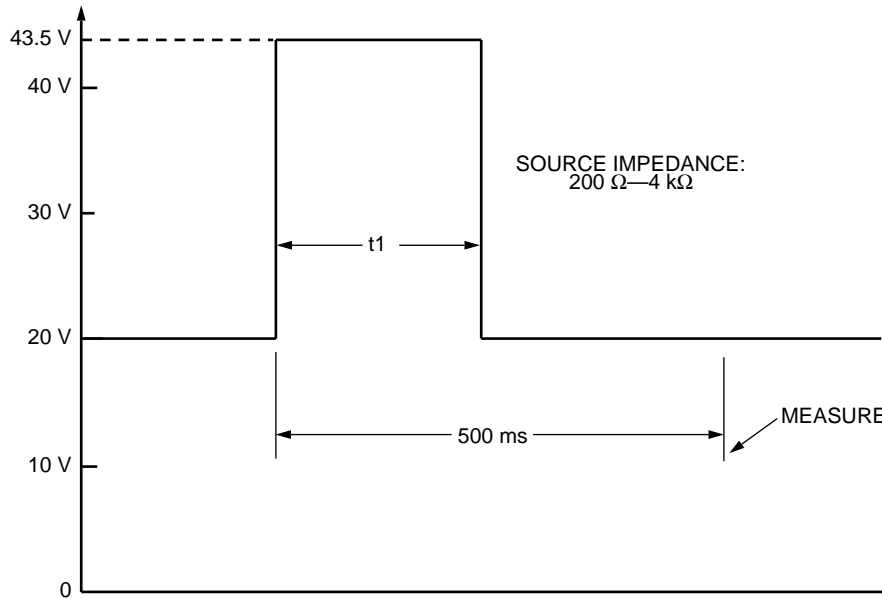

12-1942

Figure 7. Applied Waveform for Activation Test

Test Circuits (continued)

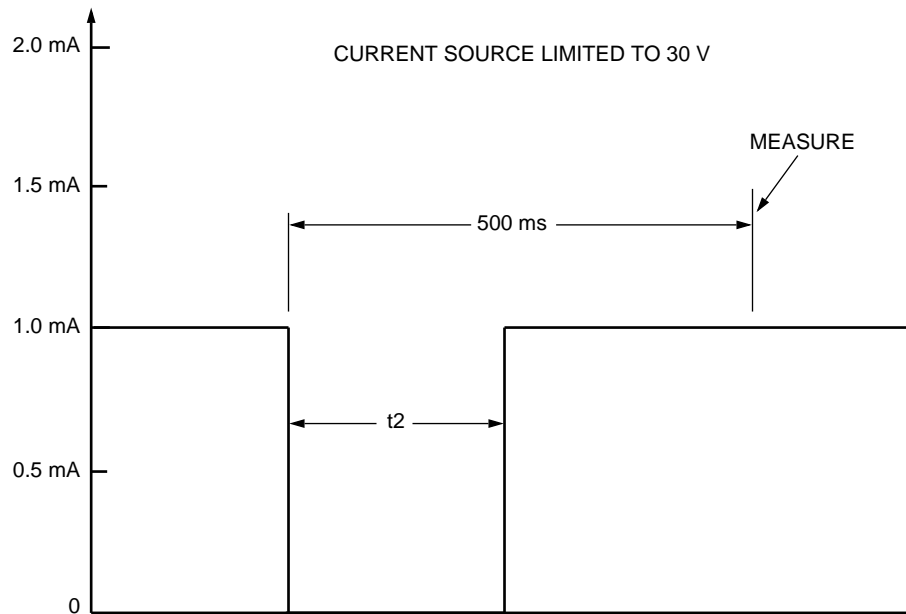

12-1943

Figure 8. Applied Waveform for Deactivation Test

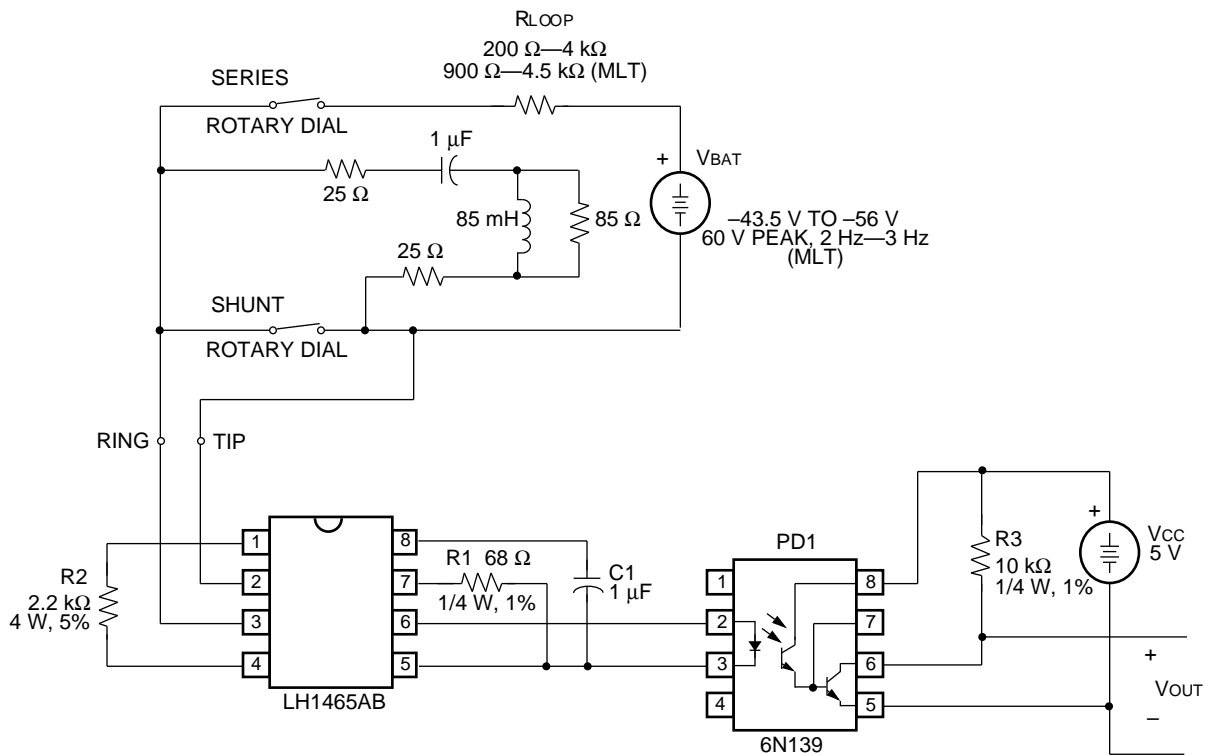

12-1944

Notes:

For series test, open SHUNT rotary dial.

For shunt test, short SERIES rotary dial.

For MLT test, short SERIES rotary dial and open SHUNT rotary dial.

Figure 9. Test Circuit for LED Operation

Test Circuits (continued)

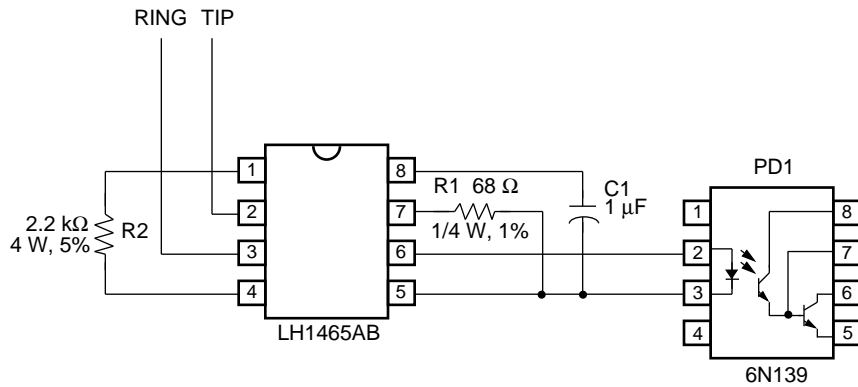

12-1945

Figure 10. Connection Diagram

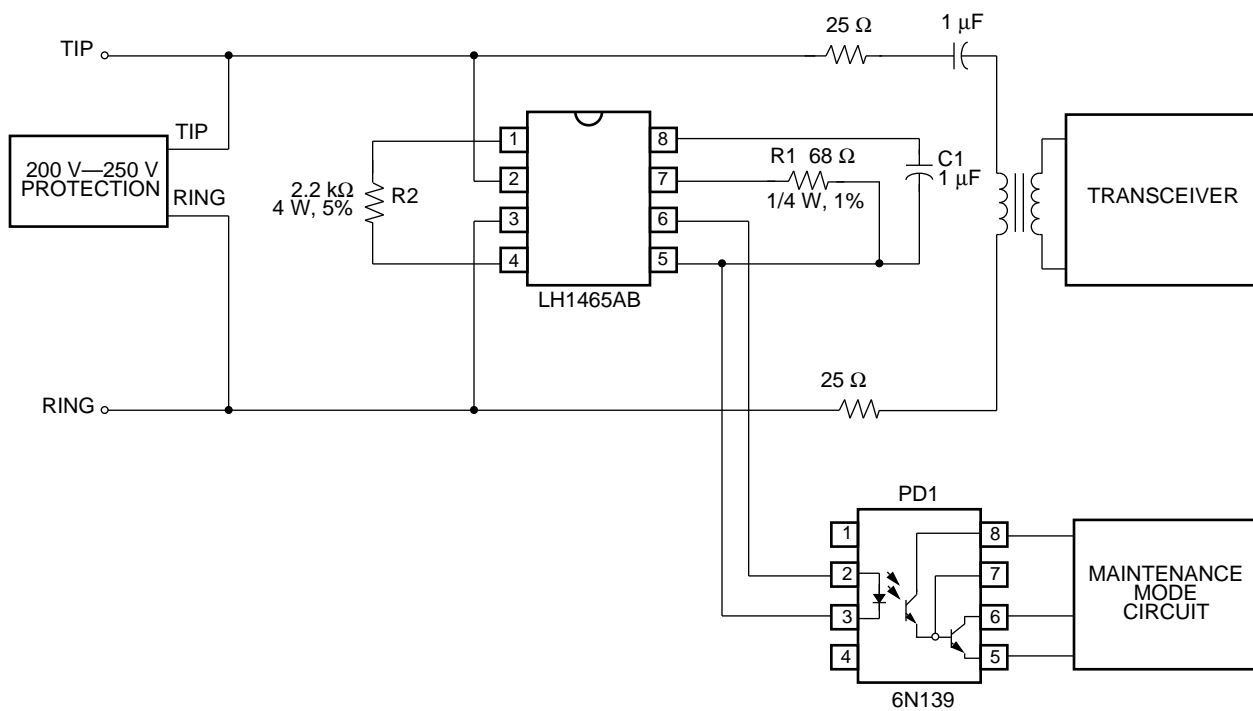

12-1946

Note: The Lucent T7256 is suitable for use as the transceiver. See Figure 6 in the T7256 Single-Chip NT1 (SCNT1) Transceiver Data Sheet for an example of a reference circuit that uses the LH1465 and the T7256.

Figure 11. Typical NT1 Application

## Outline Diagrams

Dimensions are in millimeters.

### 8-Pin, Plastic DIP (LH1465AB)

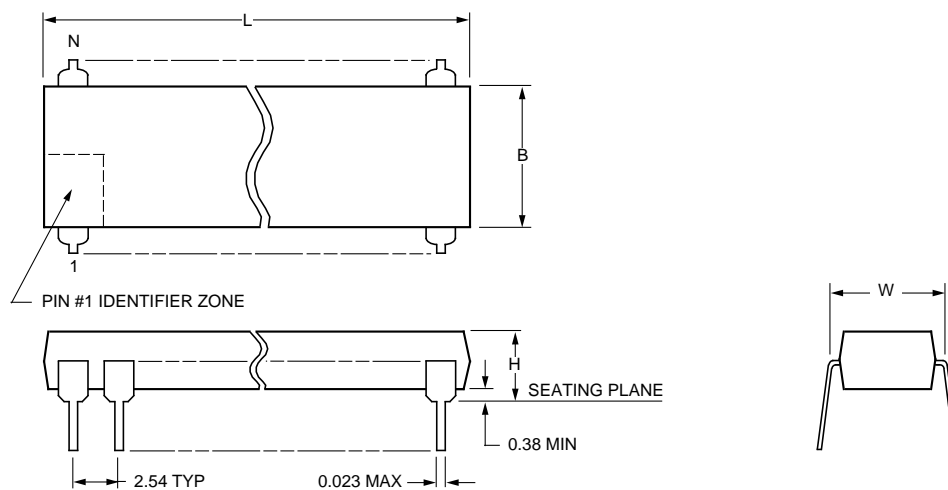

5-4410r.1

### 16-Pin, Plastic SOG (LH1465AAE)

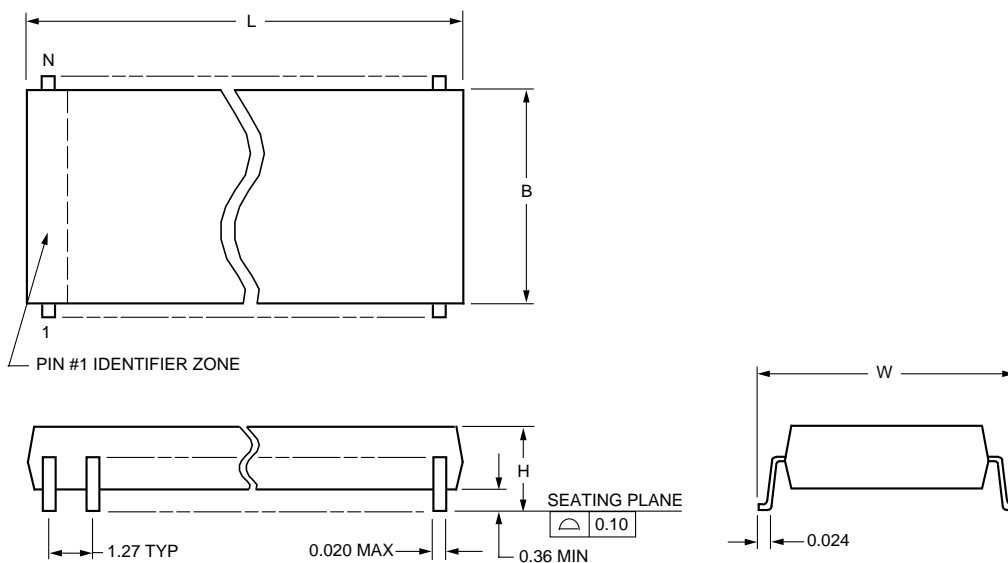

5-4414r.2

Package Description	Number of Pins (N)	Package Dimensions			
		Maximum Length (L)	Maximum Width Without Leads (B)	Maximum Width Including Leads (W)	Maximum Height Above Board (H)
PDIP3 (Plastic Dual-In-Line Package)	8	10.16	6.48	7.87	5.46
SOG (Small Outline, Gull-Wing)	16	10.49	7.62	10.64	2.67

## Ordering Information

Device	Package	Comcode
LH1465AB	8-Pin, Plastic DIP	106444987
LH1465AAE	16-Pin, Plastic SOG	106725054

For additional information, contact your Microelectronics Group Account Manager or the following:

INTERNET: <http://www.lucent.com/micro>  
 E-MAIL: [docmaster@micro.lucent.com](mailto:docmaster@micro.lucent.com)  
 U.S.A.: Microelectronics Group, Lucent Technologies Inc., 555 Union Boulevard, Room 30L-15P-BA, Allentown, PA 18103  
**1-800-372-2447**, FAX 610-712-4106 (In CANADA: **1-800-553-2448**, FAX 610-712-4106)  
 ASIA PACIFIC: Microelectronics Group, Lucent Technologies Singapore Pte. Ltd., 77 Science Park Drive, #03-18 Cintech III, Singapore 118256  
**Tel. (65) 778 8833**, FAX (65) 777 7495  
 JAPAN: Microelectronics Group, Lucent Technologies Japan Ltd., 7-18, Higashi-Gotanda 2-chome, Shinagawa-ku, Tokyo 141, Japan  
**Tel. (81) 3 5421 1600**, FAX (81) 3 5421 1700  
 EUROPE: Data Requests: MICROELECTRONICS GROUP DATALINE: **Tel. (44) 1189 324 299**, FAX (44) 1189 328 148  
 Technical Inquiries: GERMANY: **(49) 89 95086 0** (Munich), UNITED KINGDOM: **(44) 1344 865 900** (Bracknell),  
 FRANCE: **(33) 1 41 45 77 00** (Paris), SWEDEN: **(46) 8 600 7070** (Stockholm), FINLAND: **(358) 9 4354 2800** (Helsinki),  
 ITALY: **(39) 2 6601 1800** (Milan), SPAIN: **(34) 1 807 1441** (Madrid)

Lucent Technologies Inc. reserves the right to make changes to the product(s) or information contained herein without notice. No liability is assumed as a result of their use or application. No rights under any patent accompany the sale of any such product(s) or information.

