



LH2111/LH2211/LH2311 Dual Voltage Comparators

General Description

The LH2111 series of dual voltage comparators are two LM111 type comparators in a single hermetic package. Featuring all the same performance characteristics of the single, these duals offer in addition closer thermal tracking, lower weight, reduced insertion cost and smaller size than two singles. For additional information see the LM111 data sheet and National's Linear Application Handbook.

The LH2111 is specified for operation over the -55°C to $+125^{\circ}\text{C}$ military temperature range. The LH2211 is specified for operation over the -25°C to $+85^{\circ}\text{C}$ temperature range. The LH2311 is specified for operation over the 0°C to 70°C temperature range.

Features

- Wide operating supply range
- Low input currents
- High sensitivity
- Wide differential input range
- High output drive

$\pm 15\text{V}$ to a
single $+5\text{V}$
6 nA
10 μV
 $\pm 30\text{V}$
50 mA, 50V

Connection Diagram

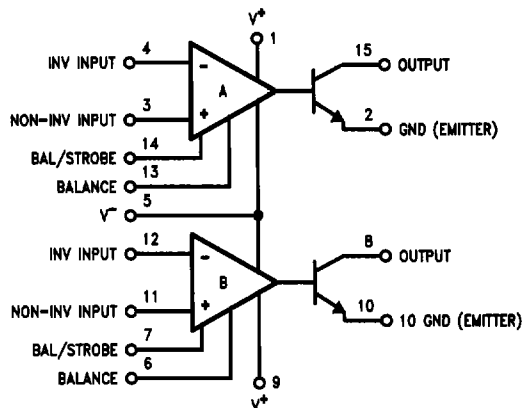

Order Number LH2111D, LH2211D or LH2311D
See NS Package Number D16C

Order Number LH2111J, LH2211J or LH2311J
See NS Package Number J16A

TL/K/10118-1

Absolute Maximum Ratings

If Military/Aerospace specified devices are required, please contact the National Semiconductor Sales Office/Distributors for availability and specifications.

Total Supply Voltage ($V^+ - V^-$)	36V
Output to Negative Supply Voltage ($V_{OUT} - V^-$)	50V
Ground to Negative Supply Voltage ($GND - V^-$)	30V
Differential Input Voltage	$\pm 30V$

Input Voltage (Note 1)	$\pm 15V$
Power Dissipation (Note 2)	500 mW
Output Short Circuit Duration	10 sec
Operating Temperature Range	LH2111 -55°C to $+125^\circ\text{C}$ LH2211 -25°C to $+85^\circ\text{C}$ LH2311 0°C to $+70^\circ\text{C}$
Storage Temperature Range	-65°C to $+150^\circ\text{C}$
Lead Temperature (Soldering, 10 sec)	300°C

Electrical Characteristics Each Side (Note 3)

Parameter	Conditions	Limits			Units
		LH2111	LH2211	LH2311	
Input Offset Voltage (Note 4)	$T_A = 25^\circ\text{C}$, $R_S \leq 50k$	3.0	3.0	7.5	mV Max
Input Offset Current (Note 4)	$T_A = 25^\circ\text{C}$	10	10	50	nA Max
Input Bias Current	$T_A = 25^\circ\text{C}$	100	100	250	nA Max
Voltage Gain	$T_A = 25^\circ\text{C}$	200	200	200	V/mV Typ
Response Time (Note 5)	$T_A = 25^\circ\text{C}$	200	200	200	ns Typ
Saturation Voltage	$V_{IN} \leq -5\text{ mV}$, $I_{OUT} = 50\text{ mA}$ $T_A = 25^\circ\text{C}$	1.5	1.5	1.5	V Max
Strobe On Current	$T_A = 25^\circ\text{C}$	3.0	3.0	3.0	mA Typ
Output Leakage Current	$V_{IN} \geq 5\text{ mV}$, $V_{OUT} = 35V$ $T_A = 25^\circ\text{C}$	10	10	50	nA Max
Input Offset Voltage (Note 4)	$R_S \leq 50k$	4.0	4.0	10	mV Max
Input Offset Current (Note 4)		20	20	70	nA Max
Input Bias Current		150	150	300	nA Max
Input Voltage Range		± 14	± 14	± 14	V Typ
Saturation Voltage	$V^+ \geq 4.5V$, $V^- = 0$ $V_{IN} \leq -5\text{ mV}$, $I_{SINK} \leq 8\text{ mA}$	0.4	0.4	0.4	V Max
Positive Supply Current	$T_A = 25^\circ\text{C}$	6.0	6.0	7.5	mA Max
Negative Supply Current	$T_A = 25^\circ\text{C}$	5.0	5.0	5.0	mA Max

Note 1: This rating applies for $\pm 15V$ supplies. The positive input voltage limit is 30V above the negative supply. The negative input voltage limit is equal to the negative supply voltage or 30V below the positive supply, whichever is less.

Note 2: The maximum junction temperature is 150°C . For operating at elevated temperatures, devices in the flat package, the derating is based on a thermal resistance of $185^\circ\text{C}/\text{W}$ when mounted on a $1/16$ -inch-thick epoxy glass board with 0.03-inch-wide, 2 ounce copper conductor. The thermal resistance of the dual-in-line package is $100^\circ\text{C}/\text{W}$, junction to ambient.

Note 3: These specifications apply for $V_S = \pm 15V$ and $-55^\circ\text{C} \leq T_A \leq 125^\circ\text{C}$ for the LH2111, $-25^\circ\text{C} \leq T_A \leq 85^\circ\text{C}$ for the LH2211, and $0^\circ\text{C} \leq T_A \leq 70^\circ\text{C}$ for the LH2311, unless otherwise stated. The offset voltage, offset current and bias current specifications apply for any supply voltage from a single 5V supply up to $\pm 15V$ supplies. For the LH2311, $V_{IN} = \pm 10\text{ mV}$.

Note 4: The offset voltages and offset currents given are the maximum values required to drive the output within a volt of either supply with a 1 mA load. Thus, these parameters define an error band and take into account the worst case effects of voltage gain and input impedance.

Note 5: The response time specified is for a 100 mV input step with 5 mV overdrive.

Auxiliary Circuits

Offset Balancing

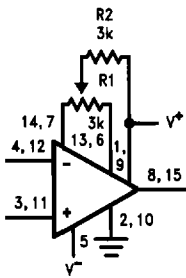

TL/K/10116-2

Strobing

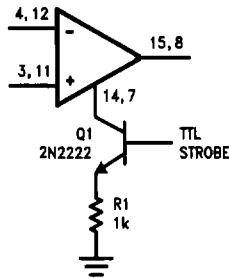

TL/K/10116-3

Increasing Input Stage Current*

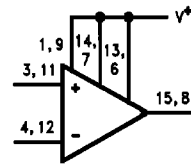

TL/K/10116-4

*Increases typical common mode slew from 7.0 V/μs to 18 V/μs

Driving Ground-Referred Load

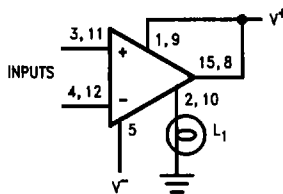

TL/K/10116-5

Using Clamp Diodes to Improve Responses

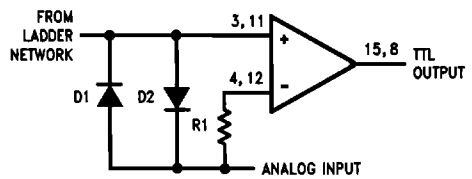

TL/K/10116-6

Comparator and Solenoid Driver

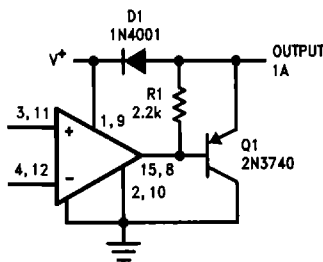

TL/K/10116-7

Strobing off Both Input* and Output Stages

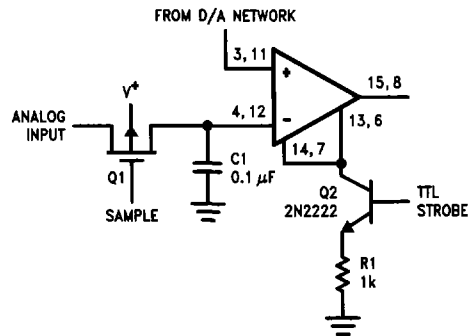

TL/K/10116-8

*Typical input current is 50 pA with inputs strobed off

TTL Interface with High Level Logic

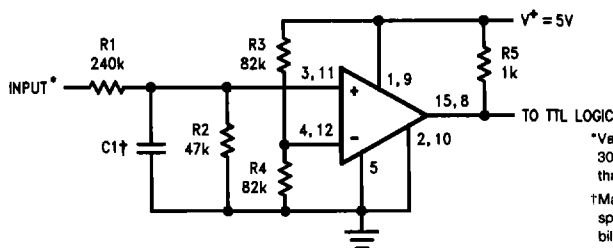

*Values shown are for a 0V to 30V logic swing and a 15V threshold.

†May be added to control speed and reduce susceptibility to noise spikes.

TL/K/10116-9