

Product Specification

1. GENERAL DESCRIPTION

The LH35WS1 is a Color Active Matrix Liquid Crystal Display with Light Emission Diode(LED) backlight system. The matrix employs poly-Si Thin Film Transistor as the active element. It is transfective type display operating in the normally black mode. This TFT-LCD has 3.54 inch diagonally measured active display area with (640*RGB*960) resolution. Each pixel is divided into Red, Green and Blue sub-pixels or dots which are arranged in vertical stripes.

Block Diagram

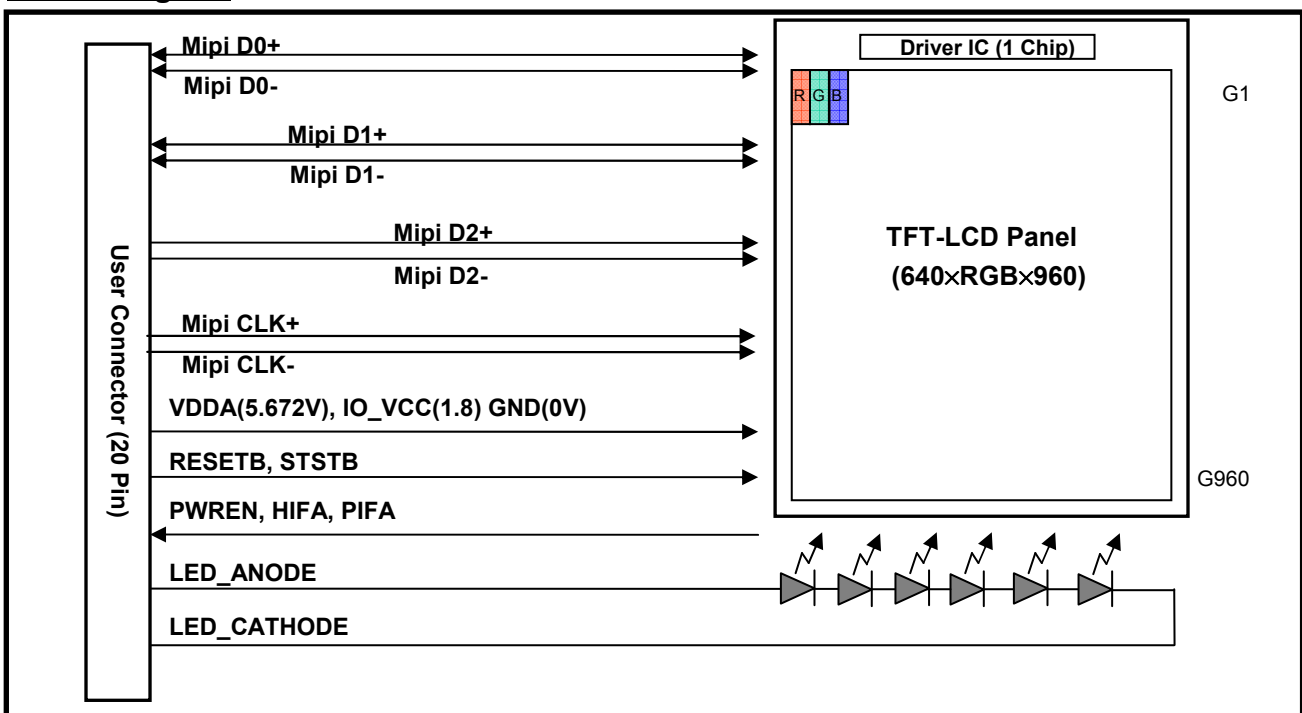

Fig 1.1 Block Diagram of TFT-LCD Module with LED Backlight Unit

General Features

Item	Specification
Active Screen Size	3.54" diagonal
Outline Dimension	54.85(H) x 82.93(V) x 1.423(T)
Pixel Pitch	0.026(H) x 0.078(V)
Pixel Format	640(H) x 960(V) (RGB Stripe)
Color Depth	24-bits (R8, G8, B8)
Interface	MIPI 3-lane, 257MHz for high speed data.
Power Consumption	470mW (Max. B/L), 113mW (Max. Panel)
Luminance	485nit(min.) @20mA
Viewing Direction	6:00 o'clock (Non-inversion)

Product Specification

2. ABSOLUTE MAXIMUM RATINGS

The following are maximum values which, if exceeded, may cause faulty operation or damage to the unit.

Table 2.1 Absolute Maximum Ratings

Parameter	Symbol	Values		Units	Notes
		Min	Max		
Switching Supply Voltage	AVDDH	-0.3	6.4	V	
Logic I/O Voltage	DVDD	-0.3	2.5	V	
Logic Input Voltage	V _{in}	-0.3	DVDD+0.3	V	1
LED Power Consumption	P _{LED}	-	120	mW	2
LED Current	I _{LED}	-	35	mA	2
Operating Temperature	T _{op}	-20	70	°C	3
Storage Temperature	T _{stg}	-30	80	°C	3
Humidity	H	5%	95%	RH	3
Maximum Pressure		100		N	4

Notes:

- (1) Applies to RESETB, PIFA, HIFA, PWREN, STSTB
- (2) Applies for each LED individually
- (3) See Section 7 for specific temperature and humidity test conditions.
- (4) Test with a 10 mm diameter metal cylinder with 2.5 mm rubber tip moving down at 1mm/minute in the center and top left corner without permanent optical change. See section 7 for additional system-level pressure testing.

Ambient Temperature vs.
Allowable Forward Current

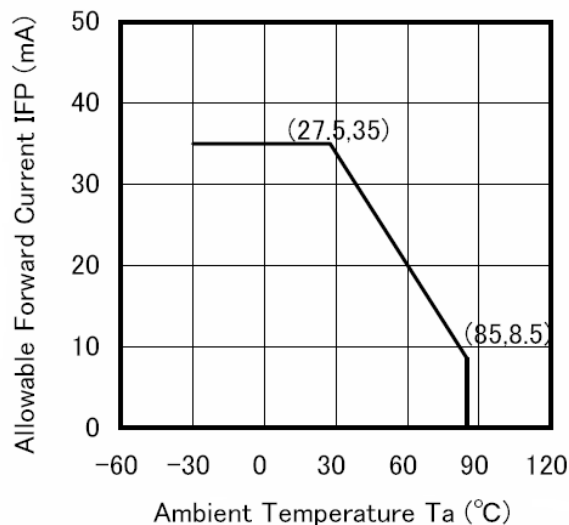

Fig 2.1 Ambient Temperature vs. Allowable Forward Current

Product Specification

3. ELECTRICAL SPECIFICATIONS

3-2. BACK LIGHT UNIT

The edge-lighting type of back light unit consists of 6 LEDs which is connected in serial.

Table 3.2 Electrical Characteristics Of Back Light Unit

Parameter	Symbol	Values			Units	Notes
		Min	Typ.	Max		
LED Current	I_{LED}	-	20	25	mA	
LED Forward Voltage	V_{LED}	-	3.2	-	V	

Product Specification

3-3. INTERFACE CONNECTIONS

Interface Connector: AX3E41264 (JAE)

Table 3.3 Module Connector Pin Configuration

Pin No.	Symbol	I/O	Description
1	GND	-	Ground
2	LED_BL_A	-	LED Anode
3	MIPI_D0P	I/O	MIPI Data
4	LED_BL_C	-	LED Cathode
5	MIPI_D0N	I/O	MIPI Data
6	5V7_AVDDH	-	Switching Power Supply
7	GND	-	Ground
8	1V8_DVDD	-	1.8V LCD Power supply
9	MIPI_D1P	I/O	MIPI Data
10	PWREN	O	System PMU Control Enable ("H" Active)
11	MIPI_D1N	I/O	MIPI Data
12	RESETB	I	Reset (" L " Active)
13	GND	-	Ground
14	HIFA	I/O	Host Interface Access
15	MIPI_CKP	I	MIPI Clock
16	STSTB	I	Set LCD Module Test (" L " Active)
17	MIPI_CKN	I	MIPI Clock
18	PIFA	I/O	Panel Interface Access
19	GND	-	Ground
20	GND	-	Ground
21	MIPI_D2P	I/O	MIPI Data
22	MIPI_D3p	I/O	MIPI Data
23	MIPI_D2N	I/O	MIPI Data
24	MIPI_D3N	I/O	MIPI Data
25	GND	-	Ground
26	GND	-	Ground

Product Specification

3-4. SIGNAL TIMING SPECIFICATIONS

Table 3.4 Timing Parameters

Item	Symbol	Timing	Unit	Remarks
Vertical cycle	VP	1000	T_{Line}	1
Vertical low pulse width	VS	16	T_{Line}	1
Vertical front porch	VFP	12	T_{Line}	1
Vertical back porch	VBP	12	T_{Line}	1
Vertical display area	VDISP	960	T_{Line}	1
Horizontal cycle	HP	1	T_{Line}	1
Horizontal low pulse width	HS+HBS	16 (min)	PCLK	2
Horizontal front porch	HFP	16 (min)	PCLK	2
Horizontal display area	HDISP	640 (max)	PCLK	2
HSYNC packet timing	T_{Line}	16.667 +/- 0.4%	us	1

Notes:

- (1) TLine is defined as time between HSYNC packets
- (2) PCLK is defined as DSICLK/4
- (3) Where min/max are not specified the values are nominal

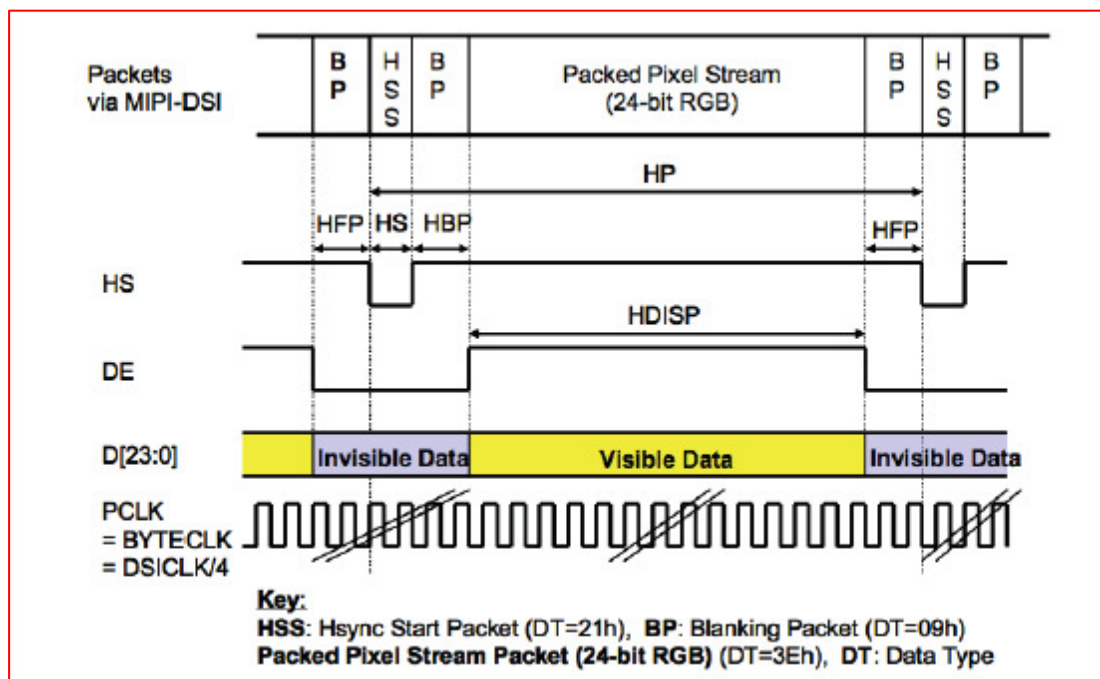

Product Specification

3-5. COLOR INPUT DATA REFERENCE

Colors & Gray Scale	Gray Scale Level	Data Signal																											
		R 0	R 1	R 2	R 3	R 4	R 5	R 6	R 7	G 0	G 1	G 2	G 3	G 4	G 5	G 6	G 7	B 0	B 1	B 2	B 3	B 4	B 5	B 6	B 7				
Black	-	0	0	0	0	0	0	0	0	0	0	0	0	0	0	0	0	0	0	0	0	0	0	0	0	0	0	0	
Blue	-	0	0	0	0	0	0	0	0	0	0	0	0	0	0	0	0	1	1	1	1	1	1	1	1	1	1	1	
Green	-	0	0	0	0	0	0	0	0	1	1	1	1	1	1	1	1	0	0	0	0	0	0	0	0	0	0	0	
Cyan	-	0	0	0	0	0	0	0	0	1	1	1	1	1	1	1	1	1	1	1	1	1	1	1	1	1	1	1	
Red	-	1	1	1	1	1	1	1	1	0	0	0	0	0	0	0	0	0	0	0	0	0	0	0	0	0	0	0	
Magenta	-	1	1	1	1	1	1	1	1	0	0	0	0	0	0	0	0	1	1	1	1	1	1	1	1	1	1	1	
Yellow	-	1	1	1	1	1	1	1	1	1	1	1	1	1	1	1	1	0	0	0	0	0	0	0	0	0	0	0	
White	-	1	1	1	1	1	1	1	1	1	1	1	1	1	1	1	1	1	1	1	1	1	1	1	1	1	1	1	
Black	G50	0	0	0	0	0	0	0	0	0	0	0	0	0	0	0	0	0	0	0	0	0	0	0	0	0	0	0	
	G51	1	0	0	0	0	0	0	0	0	0	0	0	0	0	0	0	0	0	0	0	0	0	0	0	0	0	0	
↑ Darker ↓	G52	0	1	0	0	0	0	0	0	0	0	0	0	0	0	0	0	0	0	0	0	0	0	0	0	0	0	0	
↓		↓																											
↑ Brighter ↓	G5253	1	0	1	1	1	1	1	1	0	0	0	0	0	0	0	0	0	0	0	0	0	0	0	0	0	0	0	
	G5254	0	1	1	1	1	1	1	1	0	0	0	0	0	0	0	0	0	0	0	0	0	0	0	0	0	0	0	
Red	G5255	1	1	1	1	1	1	1	1	0	0	0	0	0	0	0	0	0	0	0	0	0	0	0	0	0	0	0	
Black	G50	0	0	0	0	0	0	0	0	0	0	0	0	0	0	0	0	0	0	0	0	0	0	0	0	0	0	0	
	G51	0	0	0	0	0	0	0	0	1	0	0	0	0	0	0	0	0	0	0	0	0	0	0	0	0	0	0	
↑ Darker ↓	G52	0	0	0	0	0	0	0	0	0	1	0	0	0	0	0	0	0	0	0	0	0	0	0	0	0	0	0	
↓		↓																											
↑ Brighter ↓	G5253	0	0	0	0	0	0	0	0	1	0	1	1	1	1	1	1	0	0	0	0	0	0	0	0	0	0	0	
	G5254	0	0	0	0	0	0	0	0	0	1	1	1	1	1	1	1	0	0	0	0	0	0	0	0	0	0	0	
Green	G5255	0	0	0	0	0	0	0	0	1	1	1	1	1	1	1	1	0	0	0	0	0	0	0	0	0	0	0	
Black	G50	0	0	0	0	0	0	0	0	0	0	0	0	0	0	0	0	0	0	0	0	0	0	0	0	0	0	0	
	G51	0	0	0	0	0	0	0	0	0	0	0	0	0	0	0	0	1	0	0	0	0	0	0	0	0	0	0	
↑ Darker ↓	G52	0	0	0	0	0	0	0	0	0	0	0	0	0	0	0	0	0	1	0	0	0	0	0	0	0	0	0	
↓		↓																											
↑ Brighter ↓	G5253	0	0	0	0	0	0	0	0	0	0	0	0	0	0	0	0	1	0	1	1	1	1	1	1	1	1	1	
	G5254	0	0	0	0	0	0	0	0	0	0	0	0	0	0	0	0	0	1	1	1	1	1	1	1	1	1	1	
Blue	G5255	0	0	0	0	0	0	0	0	0	0	0	0	0	0	0	0	1	1	1	1	1	1	1	1	1	1	1	

Product Specification

3-6. Power On/off Sequence

Power On Sequence

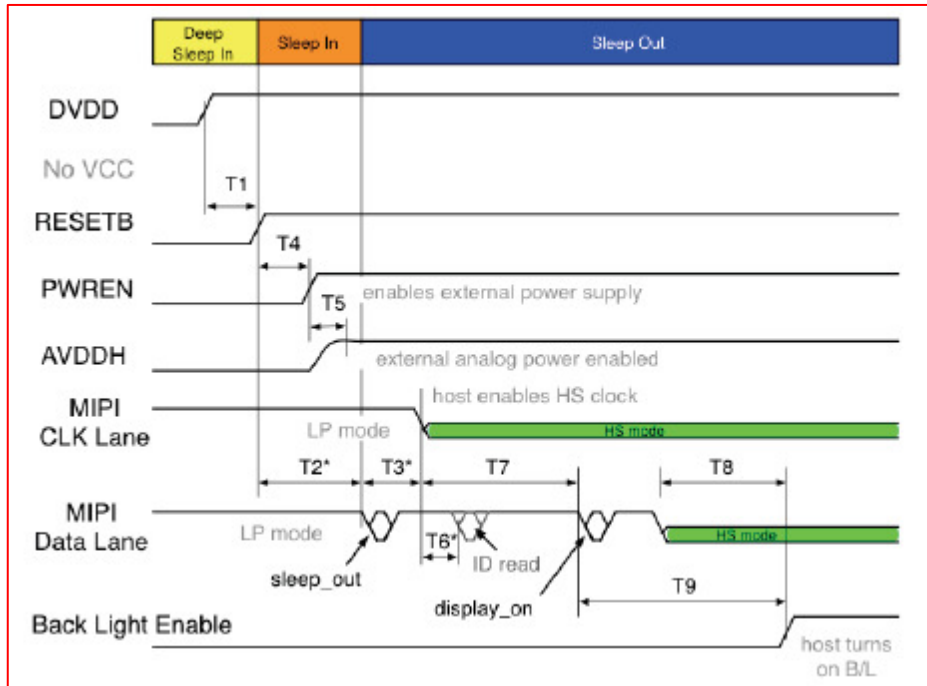

Fig 3.2 Power On Sequence

Power Off Sequence

In a normal power off sequence the commands and/or register settings are followed.

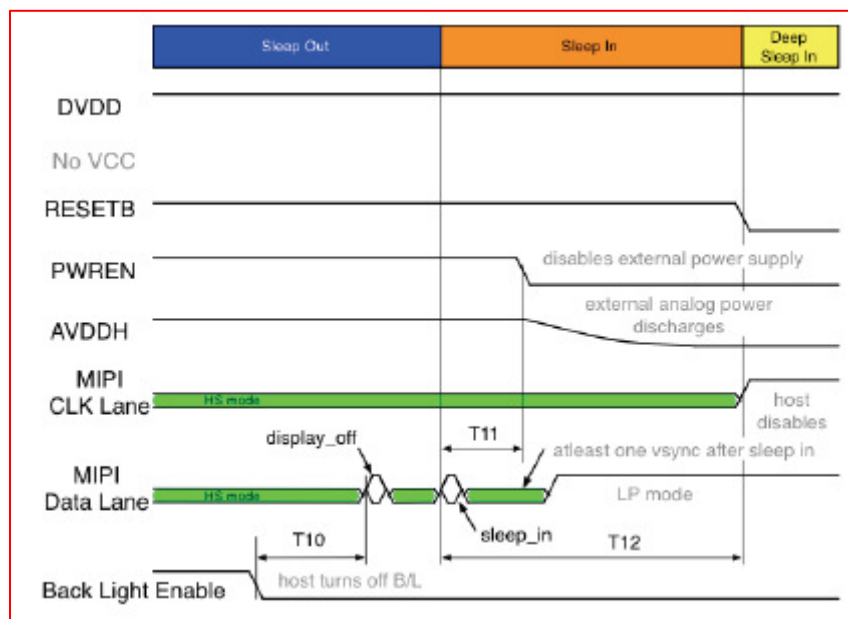

Fig 3.3 Power Off Sequence

Product Specification

3-7. Software Flow

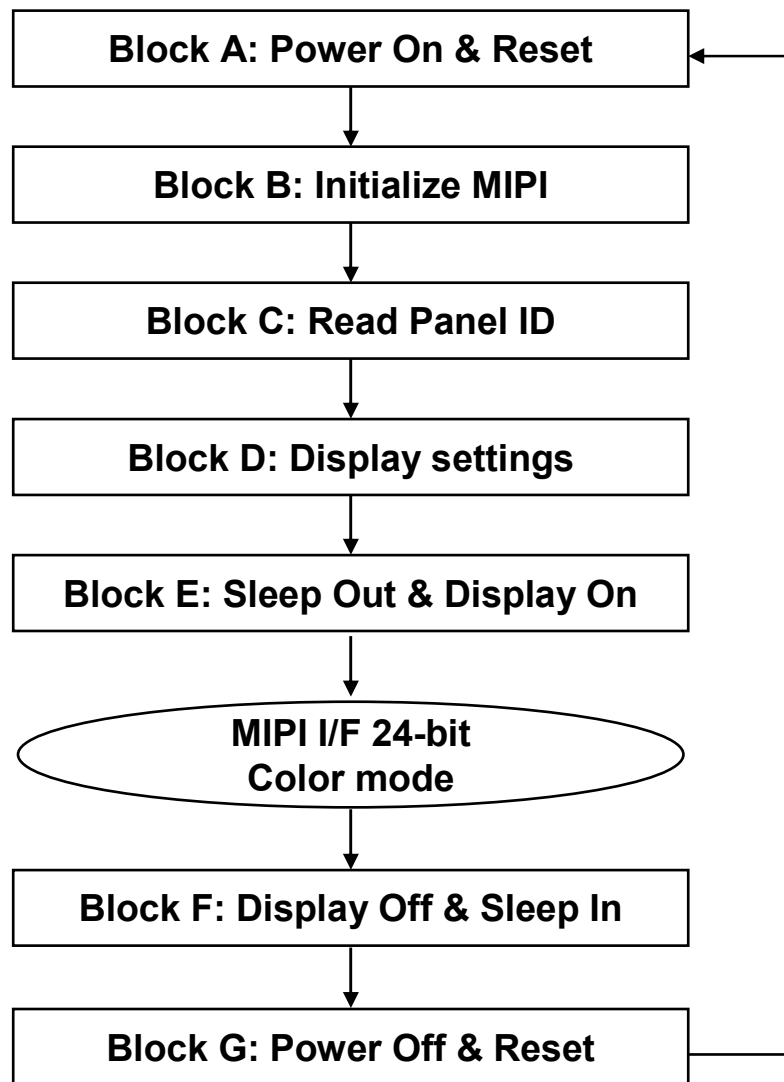

Fig 3.4 Software Flowchart

Product Specification

Table 3-5-1. Block A : Power On & Reset

Step	Operation
1	Apply DVDD
2	Toggle Reset
3	LCM sends PWREN to logic high to enable AVDDH
4	AVDDH turned on

Table 3-5-2. Block B : Initialize MIPI

Step	Register/ Command	Parameter/ Setting	Operation
1			Initialize SOC DSIM
2	0x00		Send MIPI NOP
3			Start MIPI Highspeed Clock

Table 3-5-3. Block C : Read Panel ID

Step	Register/ Command	Parameter/ Setting	Operation
1	0xB1	0x14	Read ID

Table 3-5-4. Block D : Display Settings

Step	Register/ Command	Parameter/ Setting	Operation
1	Optionally override EEPROM settings in supplier-specific electrical specification		

Table 3-5-5. Block E : Sleep Out & Display On

Step	Register/ Command	Parameter/ Setting	Operation
1	0x11		Sleep out
2	0x29		Display On

Table 3-5-6. Block F : Display Off & Sleep In

Step	Register/ Command	Parameter/ Setting	Operation
1	0x28		Display Off
2	0x10		Sleep In

Table 3-5-7. Block G : Power Off & Reset

Step	Register/ Command	Parameter/ Setting	Operation
1	Optionally override EEPROM settings in supplier-electrical specification		

Product Specification

4. OPTICAL CHARACTERISTICS

4-1. Optical Characteristics – Backlight Off

Parameter	Symbol	Condition	Min	Typ	Max	Unit	Remarks
Viewing Angle Range	Θ UP	CR \geq 10	80	-	-	$^{\circ}$ (degree)	
	Θ DOWN		80	-	-	$^{\circ}$ (degree)	
	Θ LEFT		80	-	-	$^{\circ}$ (degree)	
	Θ RIGHT		80	-	-	$^{\circ}$ (degree)	
Contrast Ratio	CR	Optimal	800	1000	-		
Brightness	Y	Optimal	485	550	-	Cd/m ²	
Brightness Uniformity	Y	Optimal	85			%	
Response time	τ_f	$\Theta = 0^{\circ}$ Ta = 25 $^{\circ}$ C		20	25	ms	
	τ_r			20	25	ms	
Max Gray to Gray	Tr or Td				30	45	ms
Color Gamut	NTSC	-	-	50	-	%	
White Chromaticity	x	CIE 1931		0.308			
	y			0.326			
Red Chromaticity	x	CIE 1931		0.610			
	y			0.345			
Green Chromaticity	x	CIE 1931		0.315			
	y			0.555			
Blue Chromaticity	x	CIE 1931		0.150			
	y			0.120			

1. Optical Test Equipment & Method Refer to Note 1,2,3,4.

Product Specification

[Note 1] Optical Test Equipment Setup

Optical characteristics are determined after the unit has been 'ON' and stable for approximately 30 minutes in a dark environment at 25°C. The values specified are at an approximate distance 50cm from the LCD surface. In case of backlight on, measured on the center area of the panel by PHOTO RESEARCH photometer PR-880&PR650 or Equivalent.

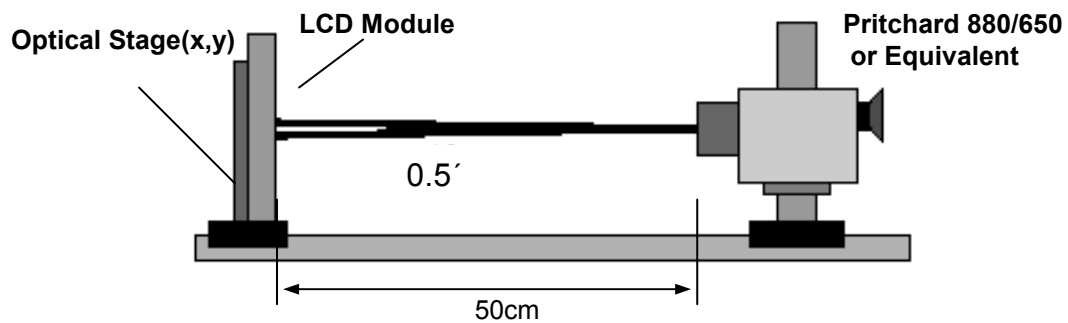

Fig 4.1. Optical Characteristic Measurement Equipment and Method

Product Specification

[Note 2]

Contrast Ratio is defined as follows ;

$$\text{Contrast Ratio(CR)} = \frac{\text{Photo detector output with LCD being "White"}}{\text{Photo detector output with LCD being "Black"}}$$

[Note 3]

Viewing Angle Range is defined as follows;

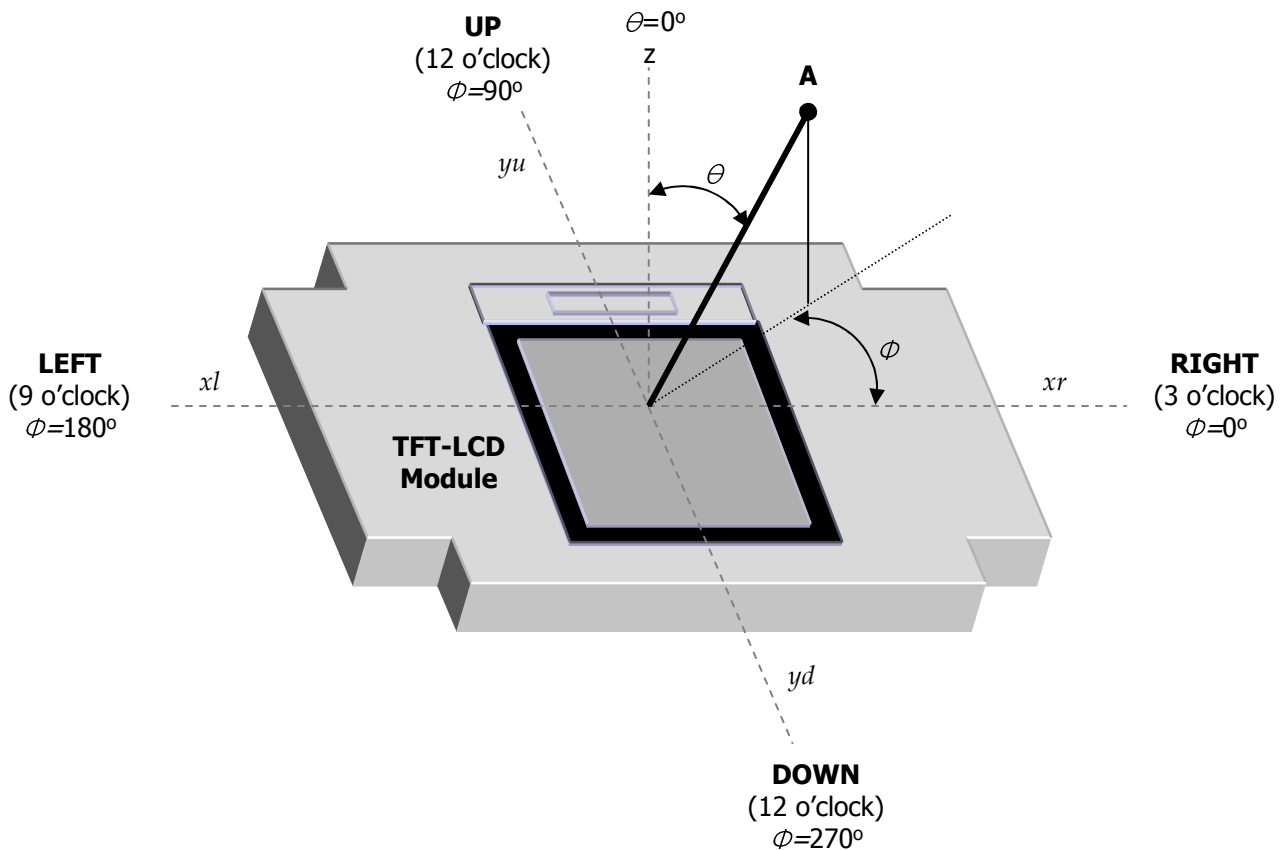

Fig 4.3 Viewing Angle Definitions

Product Specification

[Note 4]

Response time is obtained by measuring the transition time of photo detector output, when input signals are applied so as to make the area “black” to and from “white”.

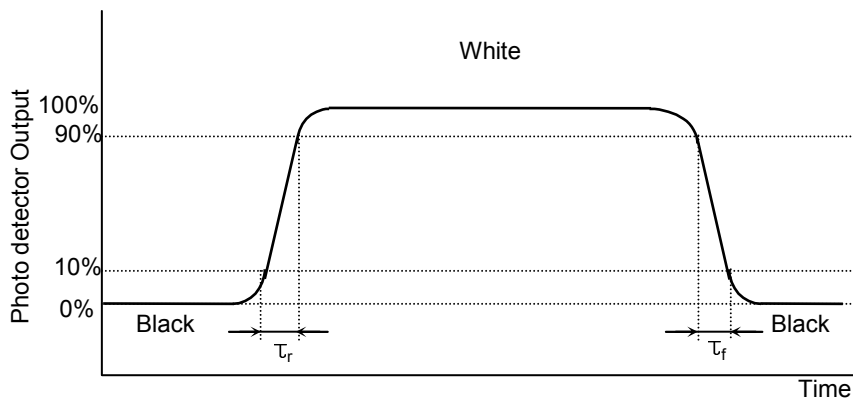

Fig 4.4 Response Time Definition

[Note 5]

The brightness measurement is taken at point B5.

$$\text{Brightness Uniformity} = \frac{\text{Minimum Photo detector output for the 13 points with all pixels white}}{\text{Maximum Photo detector output for the 13 points with all pixels white}} \times 100\%$$

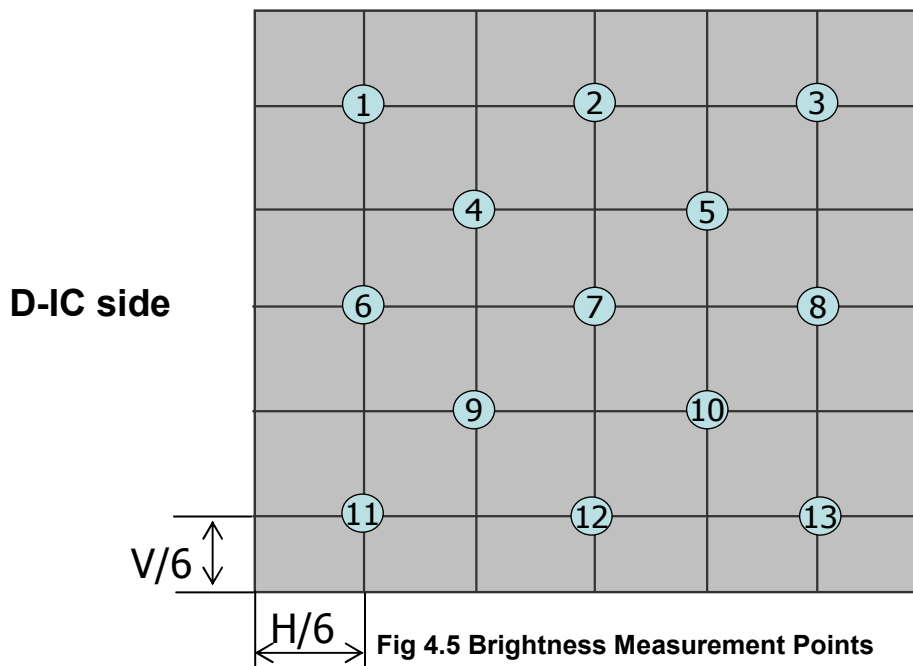

Fig 4.5 Brightness Measurement Points

Product Specification

5. MECHANICAL CHARACTERISTICS

The contents provide general mechanical characteristics for the model.
In addition the figures in the next page are detailed mechanical drawing of the LCD.

DIMENSION	MIN	TYP	MAX	UNIT
HORIZONTAL	54.75	54.85	54.95	mm
VERTICAL	82.83	82.93	83.03	mm
THICKNESS	1.32	1.441	1.520	mm

Product Specification

[Outline Dimension]

