

PREPARED BY : DATE	<b>SHARP</b>  LIQUID CRYSTAL DISPLAY GROUP SHARP CORPORATION <b>SPECIFICATION</b>	SPEC No. LD-K23130
APPROVED BY : DATE		FILE No.
		ISSUE: January, 31, 2011
		LIQUID CRYSTAL DISPLAY DIV. I LIQUID CRYSTAL DISPLAY GROUP

DEVICE SPECIFICATION FOR  
**TFT-LCD Open-Cell**  
 MODEL No. LK315D3HA54

CUSTOMERS APPROVAL

DATE \_\_\_\_\_

BY \_\_\_\_\_

BY *A. Fujisawa*

A.Fujisawa

GENERAL MANAGER

LIQUID CRYSTAL DISPLAY DIVISION I

LIQUID CRYSTAL DISPLAY GROUP

SHARP CORPORATION



## 1 Application

This specification applies to the color 31.5" TFT-LCD Open Cell LK315D3HA54.

(With parts (S-Dr, G-Dr, S-PWB) to drive it.)

- \* This specification sheets are proprietary products of SHARP CORPORATION ("SHARP") and include materials protected under copyright of SHARP. Do not reproduce or cause any third party to reproduce them in any form or by any means, electronic or mechanical, for any purpose, in whole or in part, without the express written permission of SHARP.
- \* In case of using the device for applications such as control and safety equipment for transportation (aircraft, trains, automobiles, etc.), rescue and security equipment and various safety related equipment which require higher reliability and safety, take into consideration that appropriate measures such as fail-safe functions and redundant system design should be taken.
- \* Do not use the device for equipment that requires an extreme level of reliability, such as aerospace applications, telecommunication equipment (trunk lines), nuclear power control equipment and medical or other equipment for life support.
- \* SHARP assumes no responsibility for any damage resulting from the use of the device that does not comply with the instructions and the precautions specified in these specification.
- \* Contact and consult with a SHARP sales representative for any questions about this device.

## 2 Overview

This Open Cell (LK315D3HA54) is a color active matrix LCD PANEL incorporating amorphous silicon TFT (Thin Film Transistor), polarizers, Control-PWB(C-PWB), Source-PWBs, Source-Drivers, Gate-Drivers and FFCs. The following content can be achieved in using C-PWB (LK0DZ1C0277) that SHARP specifies.

Graphics and texts can be displayed on a 1920×RGB×1080 dots panel with one billion colors by using 10bit LVDS (Low Voltage Differential Signaling) to interface, +12V of DC supply voltages.

In order to improve the response time of LCD, This C-PWB applies the Over Shoot driving (O/S driving) technology for the control circuit. In the O/S driving technology, signals are being applied to the Liquid Crystal according to a pre-fixed process as an image signal of the present frame when a difference is found between image signal of the previous frame and that of the current frame after comparing them.

With combination of these technologies, motion blur can be reduced and clearer display performance can be realized.

[Caution] You should design thermal conductive interface pad and C-PWB cover enough to radiate heat from T-CON IC in C-PWB.

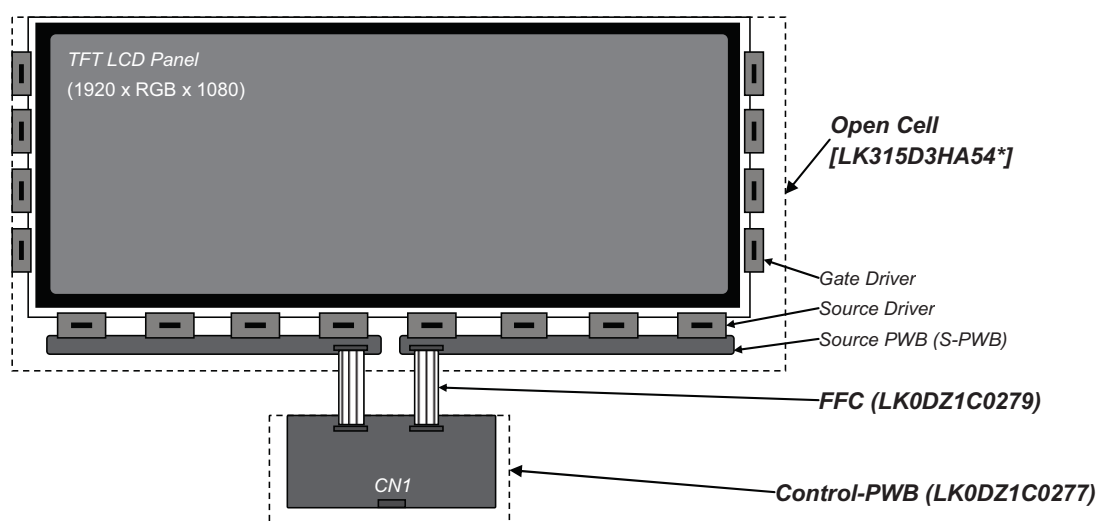

Fig.1 Overview of Open-Cell: LK315D3HA54 & peripheral parts.

### 3 Mechanical Specifications

Parameter	Specifications	Unit
Display size	80.1 (Diagonal)	cm
	31.55 (Diagonal)	inch
Active area	698.4(H) x 392.85 (V)	mm
Pixel Format	1920(H) x 1080(V) (1pixel = R + G + B dot)	pixel
Pixel pitch	0.36375(H) x 0.36375 (V)	mm
Pixel configuration	R, G, B vertical stripe	
Display mode	Normally black	
Cell Outline Dimensions[Note1]	723.1(H) x 435.3(V) x 1.8(D)	mm
Mass	1.23 ± 0.1	kg
Surface treatment [Note2]	Anti glare Hard coating : 2H and more	
Underside Surface treatment [Note2]	Hard coat less	

[Note1] Outline dimensions are shown in P19.

[Note2] With the protection film removed.

### 4 Cell Driving Specifications

#### 4.1 Driving interface of Control PWB SHARP specifics

Parts code: LK0DZ1C0277

CN1 (Interface signals and +12V DC power supply) shown in Fig.1

Using connector : 187124-51221 (P-Two)

Matching connector : I-RE51HL, FI-RE51CL (Japan Aviation Electronics Ind., Ltd.) or  
187087-51193 (P-Two) or equivalent device

Matching LVDS transmitter : THC63LVD1023 or equivalent device

Pin No.	Symbol	Function	Remark
1	GND		
2	Reserved	It is required to set non-connection(OPEN)	
3	Reserved	It is required to set non-connection(OPEN)	
4	Reserved	It is required to set non-connection(OPEN)	
5	Reserved	It is required to set non-connection(OPEN)	
6	Reserved	It is required to set non-connection(OPEN)	
7	SELLVDS	Select LVDS data order [Note 1.2]	Pull down
8	Reserved	It is required to set non-connection(OPEN)	
9	Reserved	It is required to set non-connection(OPEN)	
10	Reserved	It is required to set non-connection(OPEN)	
11	GND		
12	AIN0-	Aport (-)LVDS CH0 differential data input	
13	AIN0+	Aport (+)LVDS CH0 differential data input	
14	AIN1-	Aport (-)LVDS CH1 differential data input	
15	AIN1+	Aport (+)LVDS CH1 differential data input	
16	AIN2-	Aport (-)LVDS CH2 differential data input	
17	AIN2+	Aport (+)LVDS CH2 differential data input	
18	GND		
19	ACK-	Aport LVDS Clock signal(-)	
20	ACK+	Aport LVDS Clock signal(+)	
21	GND		
22	AIN3-	Aport (-)LVDS CH3 differential data input	
23	AIN3+	Aport (+)LVDS CH3 differential data input	
24	AIN4-	Aport (-)LVDS CH4 differential data input	
25	AIN4+	Aport (+)LVDS CH4 differential data input	
26	GND		
27	GND		
28	BIN0-	Bport (-)LVDS CH0 differential data input	
29	BIN0+	Bport (+)LVDS CH0 differential data input	
30	BIN1-	Bport (-)LVDS CH1 differential data input	
31	BIN1+	Bport (+)LVDS CH1 differential data input	

32	BIN2-	Bport (-)LVDS CH2 differential data input	
33	BIN2+	Bport (+)LVDS CH2 differential data input	
34	GND		
35	BCK-	Bport LVDS Clock signal(-)	
36	BCK+	Bport LVDS Clock signal(+)	
37	GND		
38	BIN3-	Bport (-)LVDS CH3 differential data input	
39	BIN3+	Bport (+)LVDS CH3 differential data input	
40	BIN4-	Bport (-)LVDS CH4 differential data input	
41	BIN4+	Bport (+)LVDS CH4 differential data input	
42	GND		
43	GND		
44	GND		
45	GND		
46	GND		
47	VCC	+12V Power Supply	
48	VCC	+12V Power Supply	
49	VCC	+12V Power Supply	
50	VCC	+12V Power Supply	
51	VCC	+12V Power Supply	

[Note] You should connect GND plane in Control PWB to module chassis.

[Note 1] The equivalent circuit figure of the terminal:

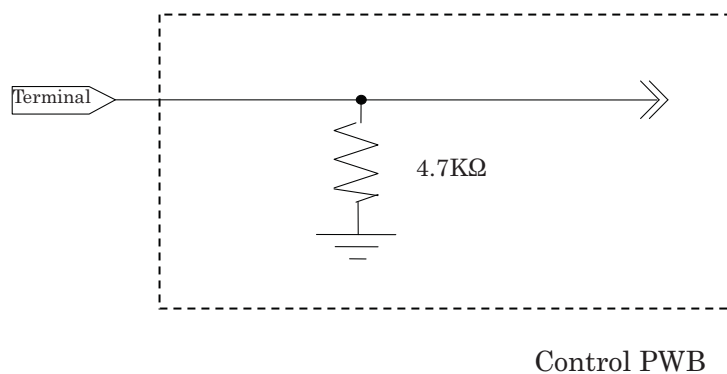

[Note 2] LVDS Data order

SELLVDS		
Data	L(GND) or Open [VESA]	H(3.3V) [JEIDA]
TA0	R0(LSB)	R4
TA1	R1	R5
TA2	R2	R6
TA3	R3	R7
TA4	R4	R8
TA5	R5	R9(MSB)
TA6	G0(LSB)	G4
TB0	G1	G5
TB1	G2	G6
TB2	G3	G7
TB3	G4	G8
TB4	G5	G9(MSB)
TB5	B0(LSB)	B4
TB6	B1	B5
TC0	B2	B6
TC1	B3	B7
TC2	B4	B8
TC3	B5	B9(MSB)
TC4	NA	NA
TC5	NA	NA
TC6	DE(*)	DE(*)
TD0	R6	R2
TD1	R7	R3
TD2	G6	G2
TD3	G7	G3
TD4	B6	B2
TD5	B7	B3
TD6	N/A	N/A
TE0	R8	R0(LSB)
TE1	R9(MSB)	R1
TE2	G8	G0(LSB)
TE3	G9(MSB)	G1
TE4	B8	B0(LSB)
TE5	B9(MSB)	B1
TE6	N/A	N/A

NA: Not Available

(\*)Since the display position is prescribed by the rise of DE(Display Enable)signal, please do not fix DE signal at "High" during operation. And you should input DE signal in all LVDS port.

**SELLVDS= Low (GND) or OPEN**

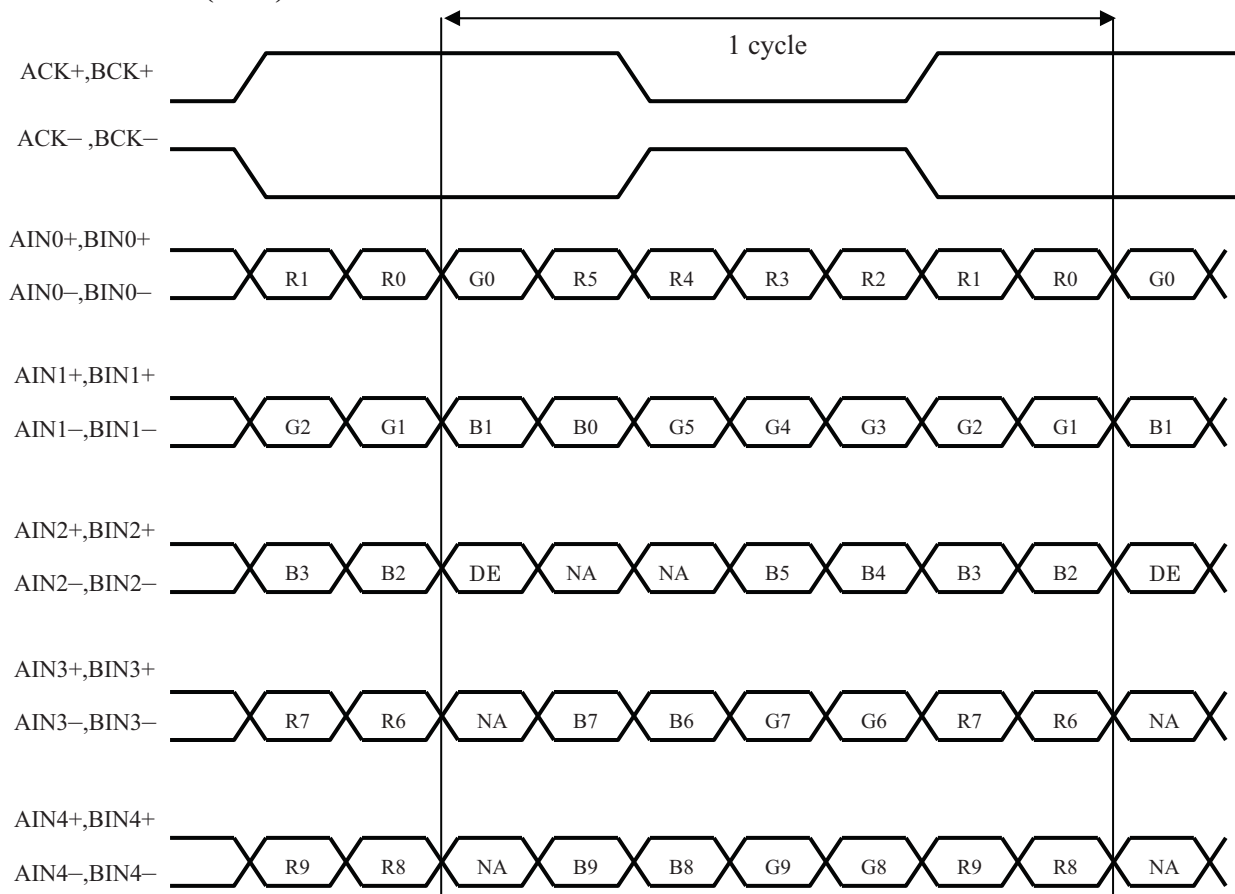

**SELLVDS= High (3.3V)**

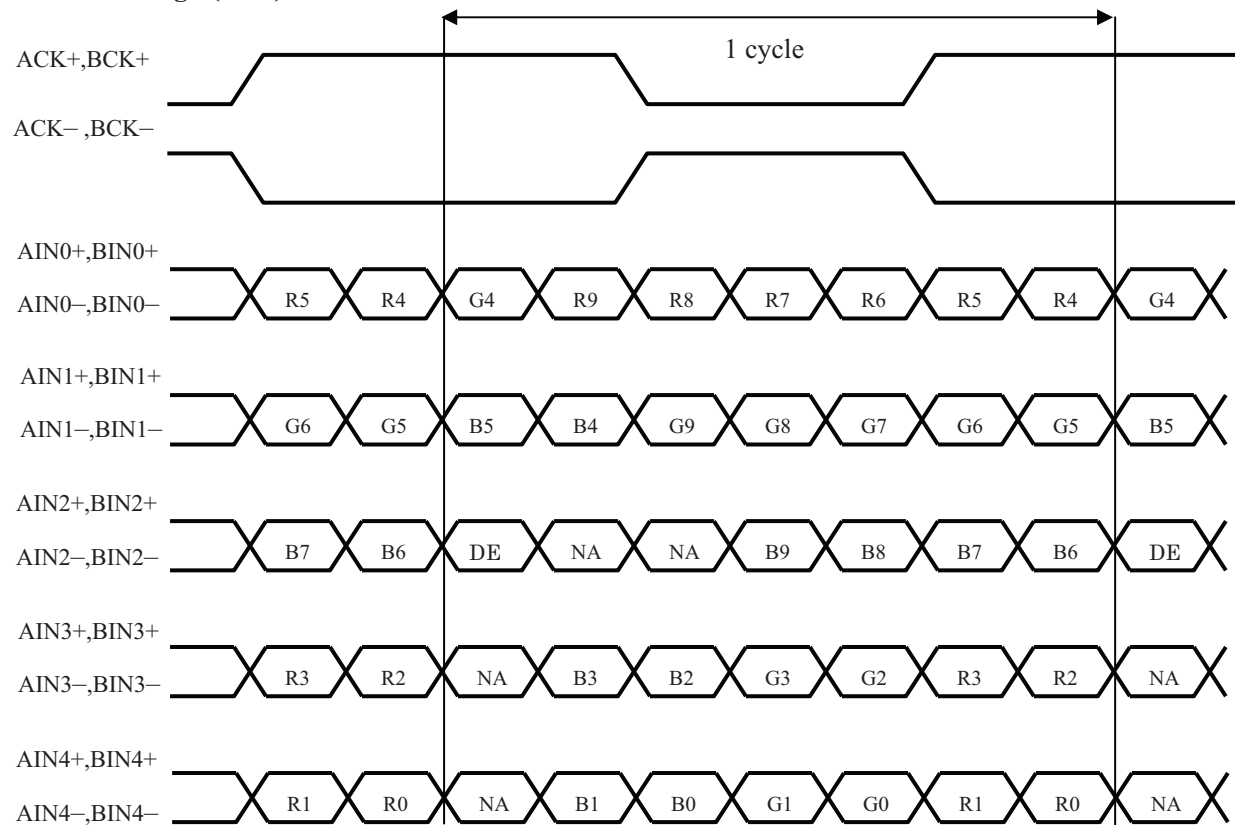

DE: Display Enable, NA: Not Available (Fixed Low)

## 4.2 Interface block diagram

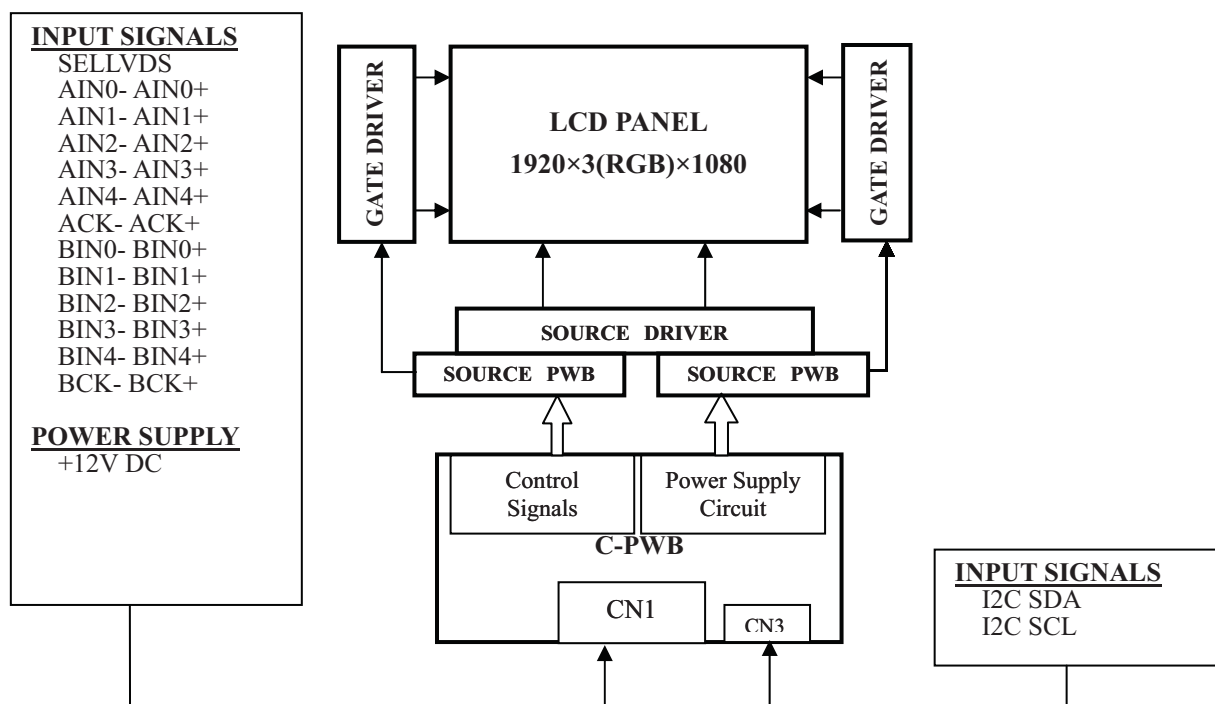
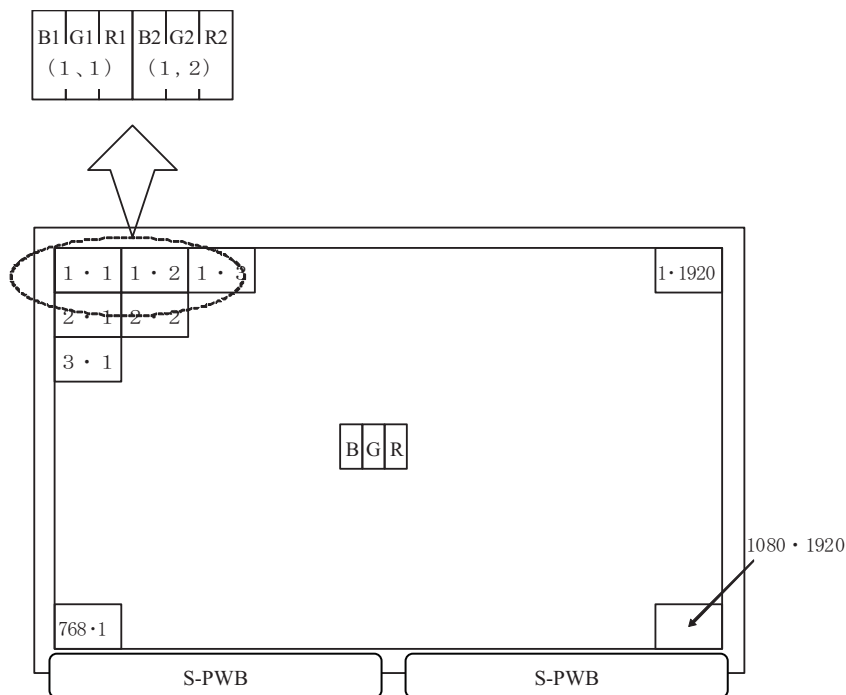

Fig.2 Interface block diagram

## 4.3 Display position of data



[Note] You should assemble Open-Cell for S-PWBs to be located at the downside of your TV set.



**4.4 Vcom Adjusting interface of Control PWB SHARP specifies[LK0DZ1C0277 (RUNTK4918TPZB) ]**

For the prevention of long-time image sticking of TFT-LCD panel, be sure to adjust Vcom flicker to be minimized on the center of display by visual or flicker meter.

[Note 1] Please adjust VCOM voltage at below pattern:

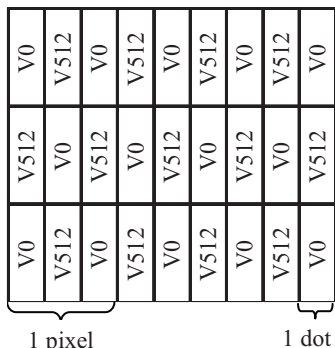

[Note 2] VCOM voltage can be adjusted through via hole (CN3). Potentiometer IC and via hole are as follows:

- IC for adjusting VCOM : MAX9667ETP+ (MAXIM)
- Using Via Hole : 1.5mm Pitch (φ0.7mm )
- Mating connector : (housing)3P-SZN,  
(contact)SZN-002T-P0.7K (JST Co.,Ltd.)

Communication method : I2C

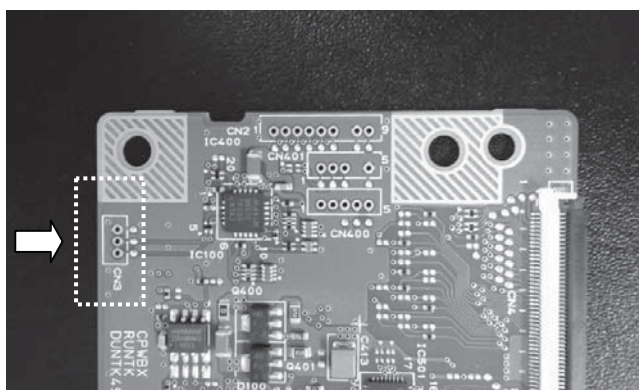

Pin No.	symbol	Function	Remark
1	SDA	I2C DATA	Pull up:3.3V[Note1]
2	SCL	I2C CLK	Pull up:3.3V[Note1]
3	GND	GND	-

[Note3] The equivalent circuit figure of the terminal

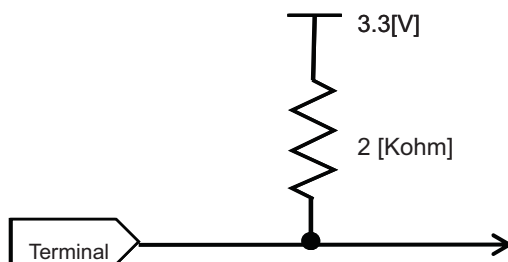

## 5 Absolute Maximum Ratings

Parameter	Symbol	Condition	Ratings	Unit	Remark
Input voltage (for Control)	V <sub>I</sub>	Ta=25 °C	-0.3 ~ 3.6	V	[Note 1]
12V supply voltage (for Control)	VCC	Ta=25 °C	0 ~ +14	V	[Note 2]
Storage temperature	Tstg	-	-25 ~ +60	°C	[Note 3]
Operation temperature (Ambient)	Topa	-	0 ~ +50	°C	

[Note 1] Applies to the input signals to C-PWB SELLVDS.

[Note 2] Applies to the supply voltage of C-PWB.

[Note 3] Applies to the LK315D3HA54 (Open-Cell) and C-PWB, CS-FPC/FFC

- Humidity: 95%RH Max.(Ta ≤ 40°C)
- Maximum wet-bulb temperature at 39°C or less. (Ta > 40°C)
- No condensation.

## 6 Electrical Characteristics of input signals

Ta=25 °C

Parameter		Symbol	Min.	Typ.	Max.	Unit	Remark
+12V supply voltage	Supply voltage	V <sub>CC</sub>	11.4	12	12.6	V	[Note 1]
	Current dissipation	I <sub>CC</sub>	-	600	1600	mA	[Note 2]
	Inrush current	I <sub>RUSH1</sub>	-	3.8	-	mA	t <sub>1</sub> =500us [Note 5]
		I <sub>RUSH2</sub>	-	1.6	-	mA	T <sub>1</sub> >5ms
Permissible input ripple voltage		V <sub>RP</sub>	-	-	100	mV <sub>P-P</sub>	V <sub>CC</sub> = +12.0V
Differential input threshold voltage	High	V <sub>TH</sub>	-	-	100	mV	V <sub>CM</sub> = +1.2V [Note 4]
	Low	V <sub>TL</sub>	-100	-	-	mV	
Input Low voltage		V <sub>IL</sub>	0	-	1.0	V	[Note 3]
Input High voltage		V <sub>IH</sub>	2.3	3.3	3.6	V	
Input leak current (Low)		I <sub>IL</sub>	-	-	400	μA	V <sub>I</sub> = 0V [Note 3]
Input leak current (High)		I <sub>IH</sub>	-	-	100	μA	V <sub>I</sub> = 3.3V [Note 3]
Terminal resistor		R <sub>T</sub>	-	100	-	Ω	Differential input

[Note]V<sub>CM</sub>: Common mode voltage of LVDS driver.

[Note1]

### Input voltage sequences

$$50\mu s < t_1 < 20ms$$

$$20ms < t_2 < 50ms$$

$$20ms < t_3 < 50ms$$

$$0 < t_4 < 1s$$

$$1s < t_{5-1}$$

$$1s < t_{5-2}$$

$$0 < t_{6-1}$$

$$0 < t_{6-2}$$

$$1s < t_7$$

$$1s < t_{8-1}$$

$$1s < t_{8-2}$$

### Dip conditions for supply voltage

$$a) 9.1V \leq V_{CC} < 10.8V$$

$$td < 10ms$$

This case is based on input voltage sequences.

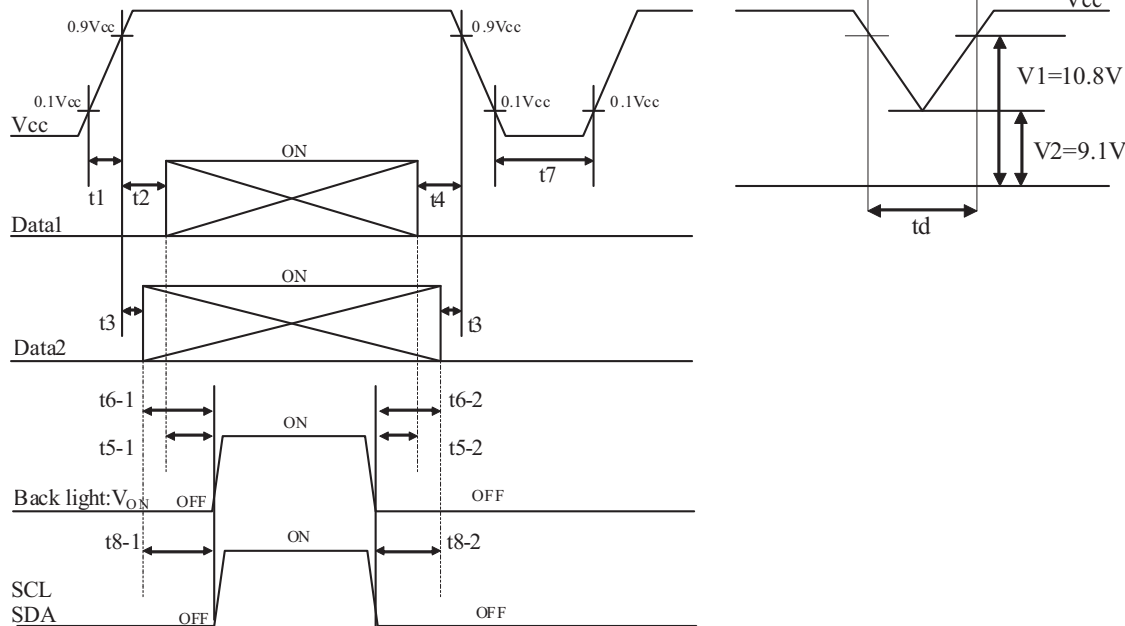

- ※ Data1: ACK±, AIN0±, AIN1±, AIN2±, AIN3±, AIN4±, BCK±, BIN0±, BIN1±, BIN2±, BIN3±, BIN4±
- ※ Data2: SELLVDS

※ About the relation between data input and back light lighting, we recommend the above-mentioned input sequence. If the back light is switched on before a panel operation begins or after a panel operation stops, the screen may not be displayed properly. But this phenomenon is not caused by change of an incoming signal, and does not give damage to a liquid crystal display.

[Note 2] Typical current situation: 1024 gray-bar patterns. (Vcc = +12.0V)

The explanation of RGB gray scale is seen in section 8.

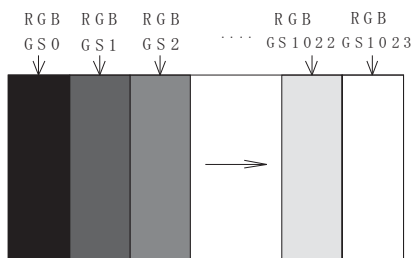

Vcc = +12.0V  
 CK = 74.25MHz  
 Th = 7.41µs

[Note 3] SELLVDS, SCL, SDA

[Note 4] ACK±, AIN0±, AIN1±, AIN2±, AIN3±, AIN4±, BCK±, BIN0±, BIN1±, BIN2±, BIN3±, BIN4±

[Note 5] Vcc12V inrush current waveform is as follows. (IRUSH : t1=500 µ s)

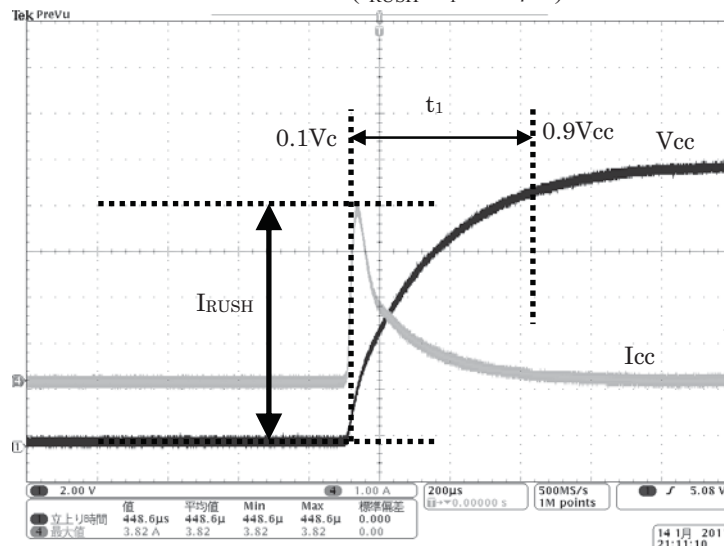

## 7 Timing characteristics of input signals for C-PWB

### 7.1 Timing characteristics

Timing diagrams of input signal are shown in Fig.3.

Parameter		Symbol	Min.	Typ.		Max.	Unit	Remark
				NTSC	PAL			
Clock	Frequency	1/Tc	69	74.25	76	MHz		
Data enable signal	Horizontal period	TH	1050	1100	1300	clock		
			14.2	14.8	16.1	μs		
	Horizontal period (High)	THd	960	960	960	clock		
	Vertical period	TV	1109	1125	1350	line	ΔA	
			47	60	50	Hz		
Vertical period (High)	TVd	1080	1080	1080	line			

[Note]-When vertical period is very long, flicker and etc. may occur.

-Please turn off the module after it shows the black screen.

-Please make sure that length of vertical period should become of an integral multiple of horizontal length of period. Otherwise, the screen may not display properly.

-As for your final setting of driving timing, we will conduct operation check test at our side, please inform your final setting.

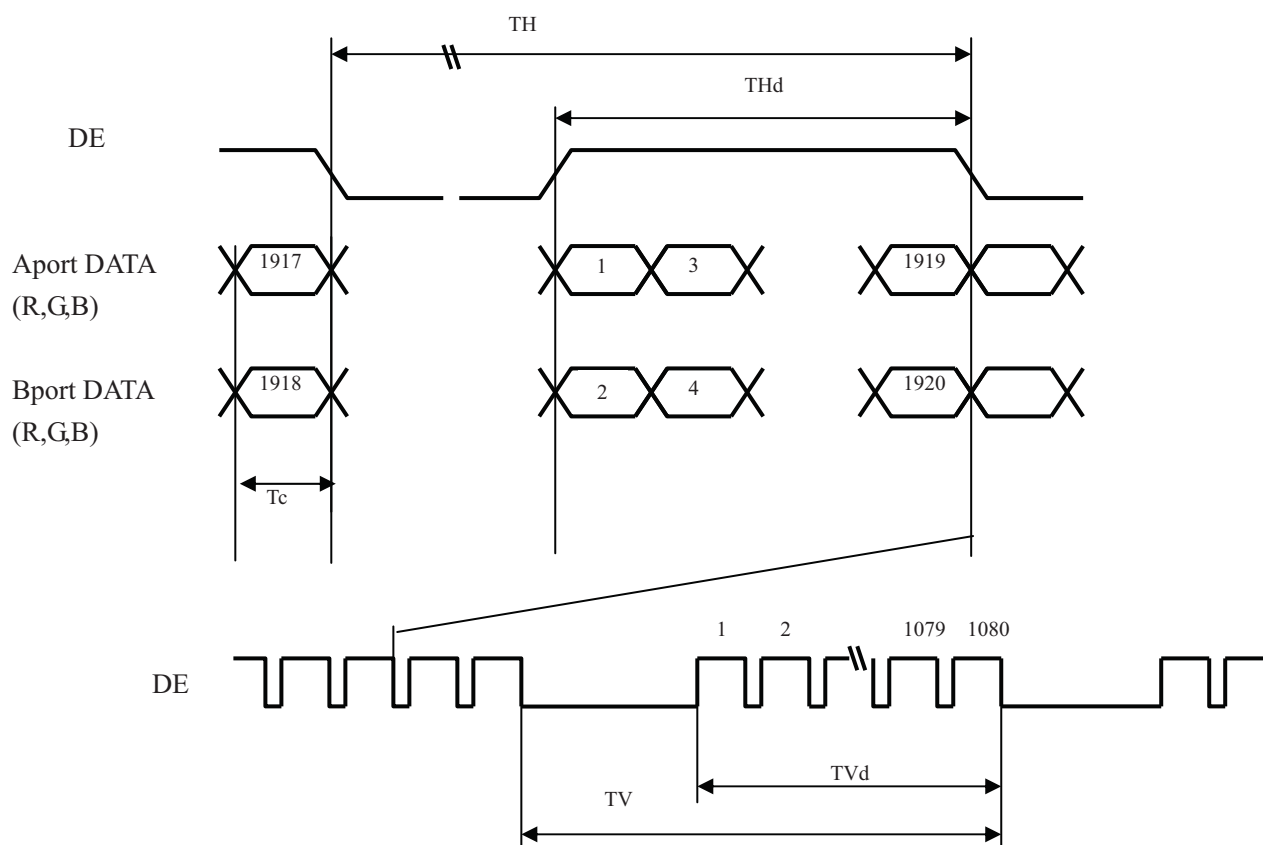
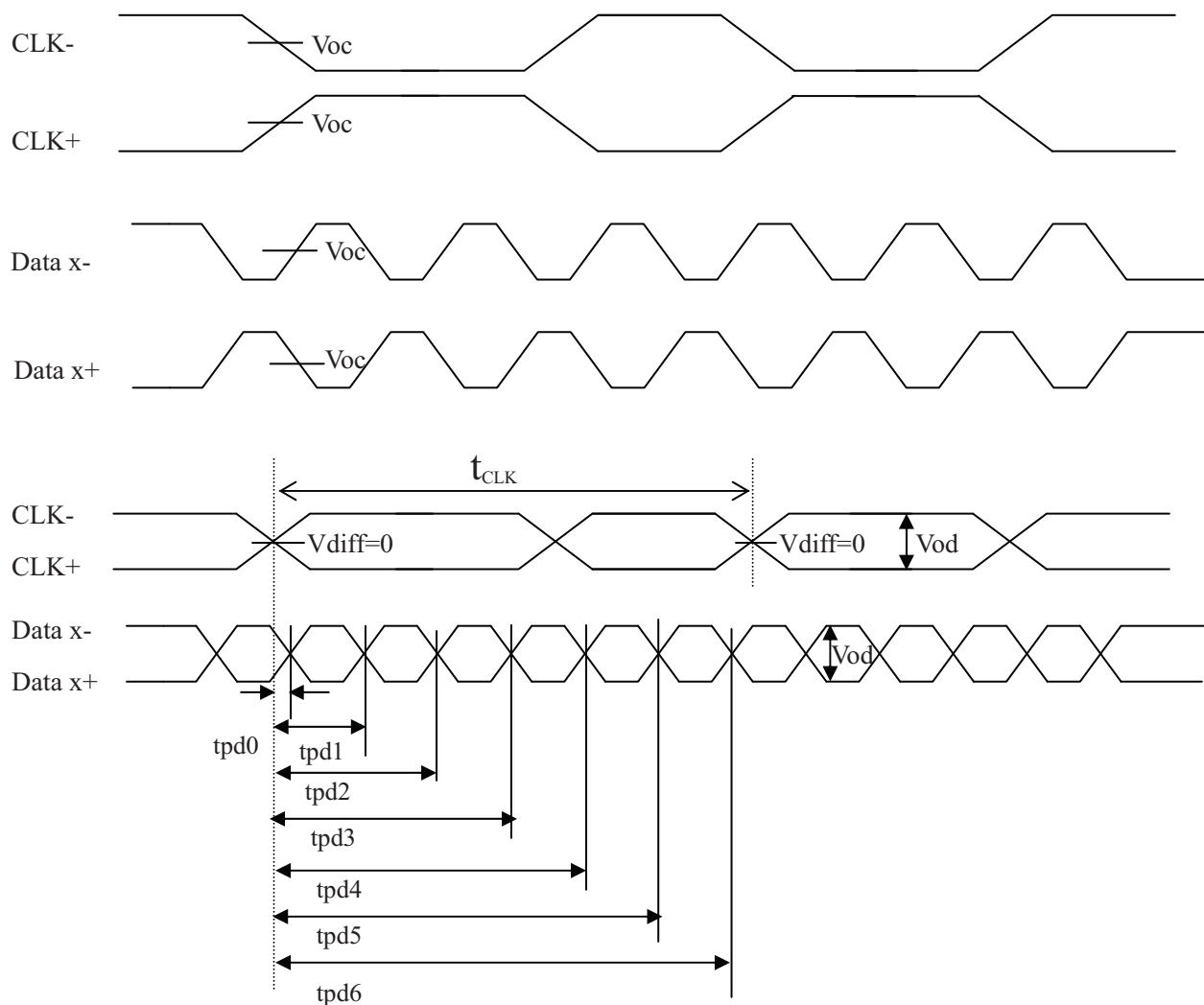

Fig.3 Timing characteristics of input signal.

### 7.2 LVDS signal characteristics



The item		Symbol	min.	typ.	max.	unit
Differential voltage		$V_{od}$	200	400	600	mV
Common mode voltage		$V_{oc}$	600	1200	1800	
LVDS clock period		$t_{CLK}$	12.35	13.50	13.69	ns
Data position	Delay time, CLK rising edge to serial bit position 0	$tpd0$	-0.25	0	0.25	
	Delay time, CLK rising edge to serial bit position 1	$tpd1$	$1 * t_{CLK} / 7 - 0.25$	$1 * t_{CLK} / 7$	$1 * t_{CLK} / 7 + 0.25$	
	Delay time, CLK rising edge to serial bit position 2	$tpd2$	$2 * t_{CLK} / 7 - 0.25$	$2 * t_{CLK} / 7$	$2 * t_{CLK} / 7 + 0.25$	
	Delay time, CLK rising edge to serial bit position 3	$tpd3$	$3 * t_{CLK} / 7 - 0.25$	$3 * t_{CLK} / 7$	$3 * t_{CLK} / 7 + 0.25$	
	Delay time, CLK rising edge to serial bit position 4	$tpd4$	$4 * t_{CLK} / 7 - 0.25$	$4 * t_{CLK} / 7$	$4 * t_{CLK} / 7 + 0.25$	
	Delay time, CLK rising edge to serial bit position 5	$tpd5$	$5 * t_{CLK} / 7 - 0.25$	$5 * t_{CLK} / 7$	$5 * t_{CLK} / 7 + 0.25$	
	Delay time, CLK rising edge to serial bit position 6	$tpd6$	$6 * t_{CLK} / 7 - 0.25$	$6 * t_{CLK} / 7$	$6 * t_{CLK} / 7 + 0.25$	



## 9 Optical Specifications

Ta=25°C, Vcc=12.0V, Frame rate:60Hz (typical)

Parameter		Symbol	Condition	Min.	Typ.	Max.	Unit	Remark
Viewing angle range	Horizontal	$\theta_{21}$ $\theta_{22}$	$CR \geq 10$	80	88	-	Deg.	[Note1,4]
	Vertical	$\theta_{11}$ $\theta_{12}$		80	88	-	Deg.	
Contrast ratio		CRn	$\theta = 0 \text{ deg.}$	4000	5000	-	-	[Note2,4]
Response time		$\tau_{DRV}$			7	-	ms	[Note3,4,5]
Luminance	White	x		Typ.-0.03	0.287	Typ.+0.03	-	[Note4]
		y		Typ.-0.03	0.290	Typ.+0.03	-	
	Red	x		Typ.-0.03	0.645	Typ.+0.03	-	
		y		Typ.-0.03	0.346	Typ.+0.03	-	
	Green	x		Typ.-0.03	0.308	Typ.+0.03	-	
		y		Typ.-0.03	0.629	Typ.+0.03	-	
	Blue	x		Typ.-0.03	0.147	Typ.+0.03	-	
		y		Typ.-0.03	0.065	Typ.+0.03	-	
Luminance	White	$Y_L$	360	450	-	cd/m <sup>2</sup>		
Luminance uniformity	White	$\delta w$	-	-	1.25		[Note 7]	

-Optical characteristics are based on SHARP standard module LK315D3LA93.

-The measurement shall be executed 60 minutes after lighting at rating.

[Note]The optical characteristics are measured using the following equipment.

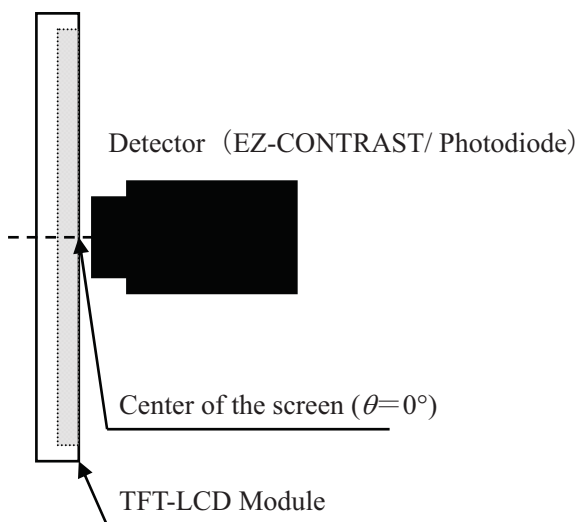

Fig.4-1 Measurement of viewing angle range and Response time.

Viewing angle range: EZ-CONTRAST

Response time: Photodiode

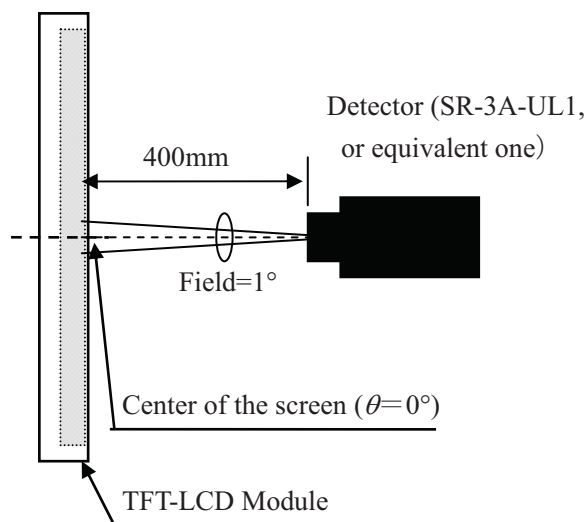
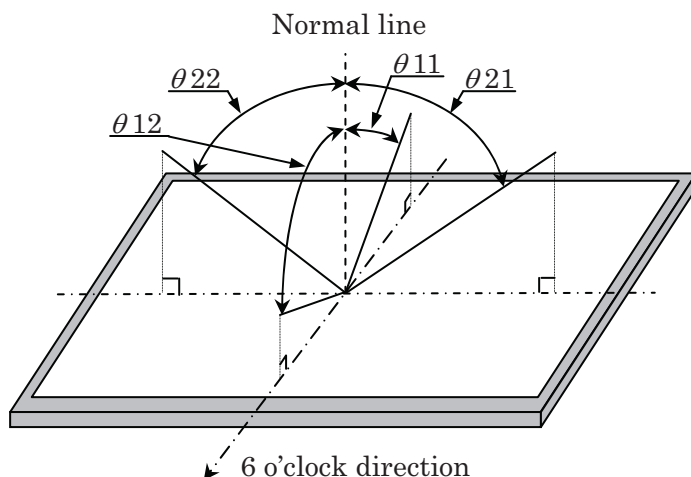

Fig.4-2 Measurement of Contrast, Luminance, Chromaticity.

[Note 1] Definitions of viewing angle range:



[Note 2] Definition of contrast ratio:

The contrast ratio is defined as the following.

$$\text{Contrast Ratio} = \frac{\text{Luminance (brightness) with all pixels white}}{\text{Luminance (brightness) with all pixels black}}$$

[Note 3] Definition of response time

The response time ( $\tau_d$  and  $\tau_r$ ) is defined as the following figure and shall be measured by switching the input signal for “any level of gray (0%, 25%, 50%, 75% and 100%)” and “any level of gray (0%, 25%, 50%, 75% and 100%)”.

	0%	25%	50%	75%	100%
0%		tr:0%-25%	tr:0%-50%	tr:0%-75%	tr:0%-100%
25%	td: 25%-0%		tr: 25%-50%	tr:25%-75%	tr: 25%-100%
50%	td: 50%-0%	td: 50%-25%		tr: 50%-75%	tr: 50%-100%
75%	td: 75%-0%	td: 75%-25%	td: 75%-50%		tr: 75%-100%
100%	td: 100%-0%	td: 100%-25%	td: 100%-50%	td:100%-75%	

t\*:x-y...response time from level of gray(x) to level of gray(y)

$$\tau_r = \Sigma(\text{tr}:x-y)/10, \tau_d = \Sigma(\text{td}:x-y)/10$$

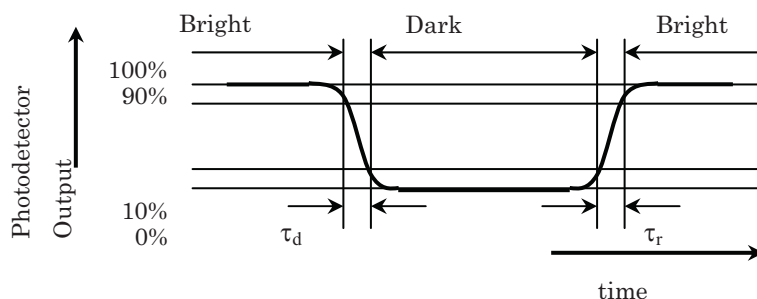

[Note 4] This shall be measured at center of the screen.

[Note 5] This value is valid when O/S driving is used at typical input time value.



[Note 6] Definition of white uniformity;

White uniformity is defined as the following with five measurements. (A~E)

$$\delta_w = \frac{\text{Maximum luminance of five points (brightness)}}{\text{Minimum luminance of five points (brightness)}}$$

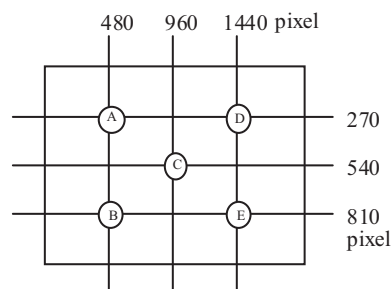

## 10 Shipping and Packing

### 10.1 Packing form

- a) Piling number of cell boxes : 14 cell box/1 palette
- b) Packing quantity in one cell box : 10 pcs
- c) Carton size : 1165(W) x 965(D) x 858(H)
- d) Total mass of one carton filled with full cell : 245.6 kg

### 10.2 Label

- a) Cell label

This label is stuck on the protection film of front polarizer. (Please trace the Cell lot number after the film is peeled off.)

ex) [LK315D3HA54] JAPAN PRODUCTION

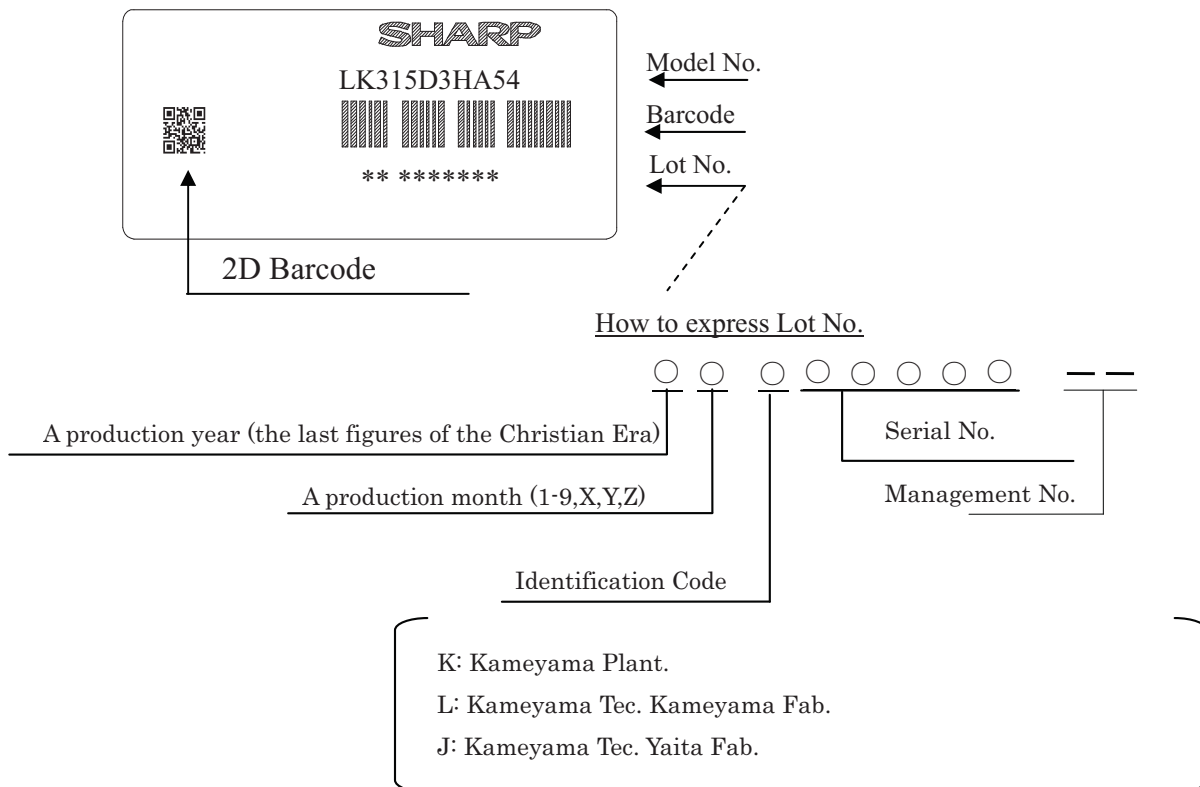

## b) Packing Label

This label is stuck on the packing case (cell box) and carton.

Ex) [LK315D3HA54] JAPAN PRODUCTION

社内品番 :	LK315D3HA54	(①)
Bar code		
Lot NO. ・ (1 T)	****. *. **	(②)
Bar code		
Quantity :	10 pcs	(③)
Bar code		
ユーザ品番		
Bar code		
シャープ物流用ラベルです。		

- ① Management No.
- ② Lot No. (Date)
- ③ Quantity

## 11 Carton storage condition.

Temperature	0°C to 40°C
Humidity	95%RH or less
Reference condition	: 20°C to 35°C, 85%RH or less (summer) : 5°C to 15°C, 85%RH or less (winter) · the total storage time (40°C, 95%RH) : 240H or less
Sunlight	Be sure to shelter a product from the direct sunlight.
Atmosphere	Harmful gas, such as acid and alkali which bites electronic components and/or wires must not be detected.
Notes	Be sure to put cartons on palette or base, don't put it on the floor, and store them keeping off the wall. Please take care of ventilation in storehouse and around cartons, and control temperature not to exceed the limit one of natural environment.
Storage life	Six months

## 12 Reliability

Reliability test item:

No.	Test item	Condition
1	High temperature storage test	Ta = 60°C 240h
2	Low temperature storage test	Ta = -25°C 240h
3	High temperature and high humidity operation test	Ta = 40°C ; 95%RH 240h (No condensation)
4	High temperature operation test	Ta = 50°C 240h
5	Low temperature operation test	Ta = 0°C 240h
6	Vibration test (Cell Box with full Open Cells)	X and Y direction: 15min, Z direction: 60min. 5Hz to 50Hz acceleration velocity: 1.0G Sweeping ratio: 3min
7	Drop test (Cell Box with full Open Cells)	Height: 25cm (corner and edge), 32cm (surface) Number: 8times (corner 1time and edge 3times and surface 4times)

Above tests are executed under the CCFL module conditions.

## 13 Precautions

- a) Be sure to turn off the power supply when inserting or disconnecting the cable.
- b) Be sure to design the cabinet so that the Open Cell can be installed without any extra stress such as warp or twist.
- c) Since the polarizer is easily damaged, pay attention not to scratch it.
- d) Since long contact with water may cause discoloration or spots, wipe off water drop immediately.
- e) When the polarizer is soiled, wipe it with absorbent cotton or other soft cloth.
- f) Since the panel is made of glass, it may break or crack if dropped or bumped on hard surface. Handle with care.
- g) Precautions of peeling off the protection film.
  - Be sure to peel off slowly (recommended more than 7sec) and constant speed.
  - Peeling direction shows below Fig.5.
  - Be sure to ground person with adequate methods such as the anti-static wrist band.
  - Be sure to ground S-PWB while peeling of the protection film.
  - Ionized air should be blown over during peeling action.
  - The protection film must not touch drivers and S-PWBs.
  - If adhesive may remain on the polarizer after the protection film peeling off, please remove with isopropyl-alcohol.

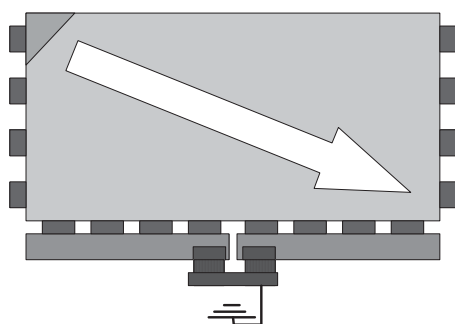

Fig.5 Direction of peeling off a protection film.

- h) Since the Open Cell consists of TFT and electronic circuits with CMOS-ICs, which are very weak to electrostatic discharges, persons who are handling the Open Cell should be grounded through adequate methods such as the anti-static wrist band. Connector pins should not be touched directly with bare hands.

- Reference : Process control standard of sharp

	Item	Management standard value and performance standard
1	Anti-static mat (floor)	1 to 50 [M ohm]
2	Anti-static mat (shelf, desk)	1 to 100 [M ohm]
3	Ionizer	Attenuate from +1000V to +100V within 2 sec
4	Anti-static wrist band	0.8 to 10 [M ohm]
5	Anti-static wrist band entry and ground resistance	Below 1000 [ohm]
6	Temperature	22 to 26 [°C]
7	Humidity	60 to 70 [%RH]

- i) The Open Cell has some PWBs, take care to prevent them from any stress or pressure when handling or installing the Open Cell, otherwise some of electronic parts on the PWBs may be damaged.
- j) Be sure to turn off the power supply when inserting or disconnecting the cable.
- k) Be sure to design the module and cabinet so that the Open Cell can be installed without any extra stress such as warp or twist.
- l) When handling the Open Cell and assembling them into module and cabinets, please be noted that long-term storage in the environment of oxidization or deoxidization gas and the use of such materials as reagent, solvent, adhesive, resin, etc. which generate these gasses, may cause corrosion and discoloration of the Open Cell.
- m) Applying too much force and stress to PWB and driver may cause a malfunction electrically and mechanically.
- n) The Open Cell has high frequency circuits. Sufficient suppression to EMI should be done by system manufacturers.
- o) Please be careful since image retention may occur when a fixed pattern is displayed for a long time.
- p) The chemical compound, which causes the destruction of ozone layer, is not used.
- q) This Open Cell is corresponded to RoHS. "R.C." label on the side of palette shows it.
- r) When any question or issue occurs, it shall be solved by mutual discussion.

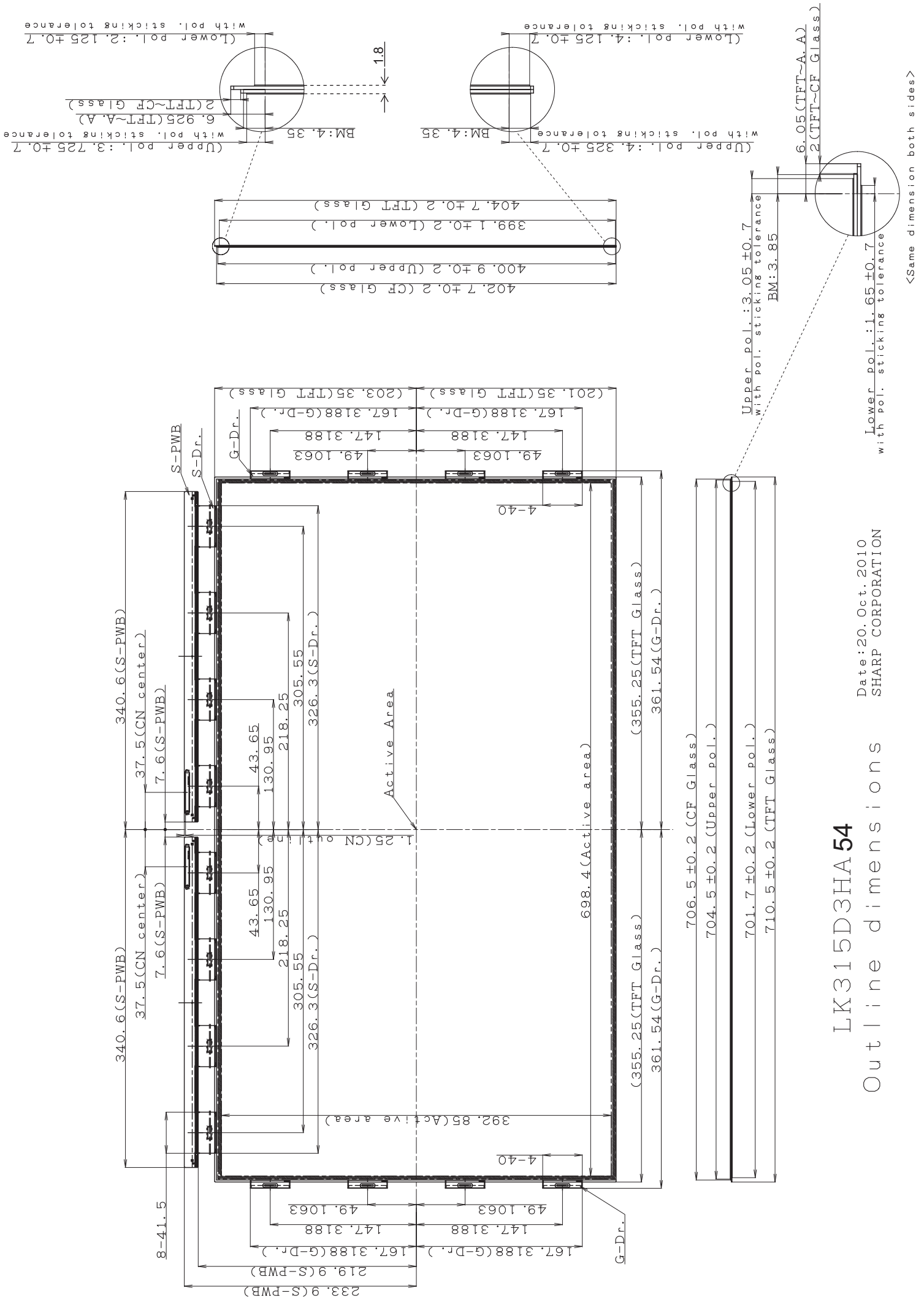

<Same dimension both sides>

Date: 20. Oct. 2010  
SHARP CORPORATION

# LK315D3HA54 Outline dimensions

