

PREPARED BY: _____	DATE _____	<b>SHARP</b>	SPEC No. LD-K22Z01
APPROVED BY: _____	DATE _____		FILE No.
			ISSUE: January, 27, 2011
			PAGE :19 pages
		LIQUID CRYSTAL DISPLAY GROUP SHARP CORPORATION	APPLICABLE GROUP LIQUID CRYSTAL DISPLAY DISPLAY DIVISION I

DEVICE SPECIFICATION FOR  
**TFT-LCD Cell**  
 MODEL No. LK315T3HA39

CUSTOMER'S APPROVAL

DATE \_\_\_\_\_

BY \_\_\_\_\_

PRESENTED

By A. Fujisawa

A.Fujisawa

GENERAL MANAGER

LIQUID CRYSTAL DISPLAY DIVISION I

LIQUID CRYSTAL DISPLAY GROUP

SHARP CORPORATION



## 1. Application

This specification applies to the color 31.5" TFT-LCD Open-Cell (LK315T3HA39)

- \* This specification is proprietary product of SHARP CORPORATION ("SHARP") and includes materials protected under copyright of SHARP. Do not reproduce or cause any third party to reproduce them in any form or by any means, electronic or mechanical, for any purpose, in whole or in part, without the express written permission of SHARP.
- \* In case of using the device for applications such as control and safety equipment for transportation (aircraft, trains, automobiles, etc.), rescue and security equipment and various safety related equipment which require higher reliability and safety, take into consideration that appropriate measures such as fail-safe functions and redundant system design should be taken.
- \* Do not use the device for equipment that requires an extreme level of reliability, such as aerospace applications, telecommunication equipment (trunk lines), nuclear power control equipment and medical or other equipment for life support.
- \* SHARP assumes no responsibility for any damage resulting from the use of the device that does not comply with the instructions and the precautions specified in this technical literature.
- \* Contact and consult with a SHARP sales representative for any questions about this device.

## 2. Overview

This Open-Cell is a color active matrix LCD panel incorporating amorphous silicon TFT (Thin Film Transistor). It is composed of a color TFT-LCD panel, driver ICs, Source-Control and Source-PWB.

Graphics and texts can be displayed on a 1366×RGB×768 dots panel with 16,777,216 colors by using LVDS (Low Voltage Differential Signaling) for the interface and +12V DC supply voltage, which are put into Source-Control PWB.

This applies the Over Shoot driving (O/S driving) technology, signals are being applied to the Liquid Crystal according to a pre-fixed process as image signals of the present frame when a difference is found between image signals of the previous and current frame by comparing each other. The O/S driving technology makes the Liquid Crystal response within 1 frame completely, motion blur reduce, so that clearer display performance can be realized.

## 3. Mechanical Technical literatures

Parameter	Technical literatures	Unit
Display size	80.039 (Diagonal)	cm
	31.5 (Diagonal)	inch
Active area	697.69 (H) × 392.26 (V)	mm
Pixel Format	1366 (H) × 768 (V) (1pixel = R + G + B dot)	pixel
Pixel pitch	0.51075(H) × 0.51075 (V)	mm
Pixel configuration	R,G, B vertical stripe	
Display mode	Normally black	
Outline Dimensions with SOF and PWB [Note1]	724.9(W) x 458.2(H) x 5.2(D)	mm
Mass	1.23	kg
Surface treatment [Note2] (Front Polarizing film)	Low-Haze Anti Glare Hard coating: 2H	
Surface treatment [Note2] (Rear Polarizing film)	Plain	

[Note1] Outline dimensions are shown in P18.

[Note2] Without the protection film.

## 4. Cell driving technical literatures

### 4.1. TFT panel driving

CN1 (Interface signals and +12V DC power supply; shown in Fig.1)

Using connector: GT103-30S-H23-D-E2500 (LSMtron)

Mated connector: FI-X30H/FI-X30HL, FI-X30C/FI-X30C2L

or FI-X30M (Japan Aviation Electronics Ind. , Ltd.)

Mated LVDS transmitter: THC63LVDM83R (THine) or equivalent device

Pin No.	Symbol	Function	Remark
1	VCC	+12V Power Supply	
2	VCC	+12V Power Supply	
3	VCC	+12V Power Supply	
4	VCC	+12V Power Supply	
5	GND	Ground	
6	GND	Ground	
7	GND	Ground	
8	GND	Ground	
9	SELLVDS	Select LVDS data order [Note 1]	Default: Pull down (L:GND) [Note 2]
10	Reserved	Not Available	
11	GND	Ground	
12	RIN0-	Negative (-) LVDS differential data input	LVDS
13	RIN0+	Positive (+) LVDS differential data input	LVDS
14	GND	Ground	
15	RIN1-	Negative (-) LVDS differential data input	LVDS
16	RIN1+	Positive (+) LVDS differential data input	LVDS
17	GND	Ground	
18	RIN2-	Negative (-) LVDS differential data input	LVDS
19	RIN2+	Positive (+) LVDS differential data input	LVDS
20	GND	Ground	
21	CLKIN-	Clock Signal(-)	LVDS
22	CLKIN+	Clock Signal(+)	LVDS
23	GND	Ground	
24	RIN3-	Negative (-) LVDS differential data input	LVDS
25	RIN3+	Positive (+) LVDS differential data input	LVDS
26	GND	Ground	
27	Reserved	Not Available	
28	Reserved	Not Available	
29	GND	Ground	
30	GND	Ground	

[Note] GND of a liquid crystal panel drive part has connected with a module chassis.

## [Note1] LVDS data order

Transmitter		SELLVDS	
Pin No	Data	= L(GND) or Open	= H(3.3V)
51	TA0	R0(LSB)	R2
52	TA1	R1	R3
54	TA2	R2	R4
55	TA3	R3	R5
56	TA4	R4	R6
3	TA5	R5	R7(MSB)
4	TA6	G0(LSB)	G2
6	TB0	G1	G3
7	TB1	G2	G4
11	TB2	G3	G5
12	TB3	G4	G6
14	TB4	G5	G7(MSB)
15	TB5	B0(LSB)	B2
19	TB6	B1	B3
20	TC0	B2	B4
22	TC1	B3	B5
23	TC2	B4	B6
24	TC3	B5	B7(MSB)
27	TC4	NA	NA
28	TC5	NA	NA
30	TC6	DE(*)	DE(*)
50	TD0	R6	R0(LSB)
2	TD1	R7(MSB)	R1
8	TD2	G6	G0(LSB)
10	TD3	G7(MSB)	G1
16	TD4	B6	B0(LSB)
18	TD5	B7(MSB)	B1
25	TD6	NA	NA

NA: Not Available

(\*) Since the display position is prescribed by the rise of DE (Display Enable) signal, please do not fix DE signal at "High" during operation.

## [Note 2] The equivalent circuit figure of the terminal

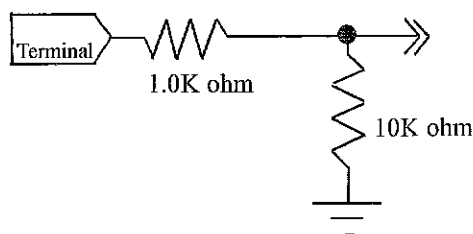

• Interface block diagram

Corresponding transmitter: THC63LVDM83R (THINE) or equivalent device

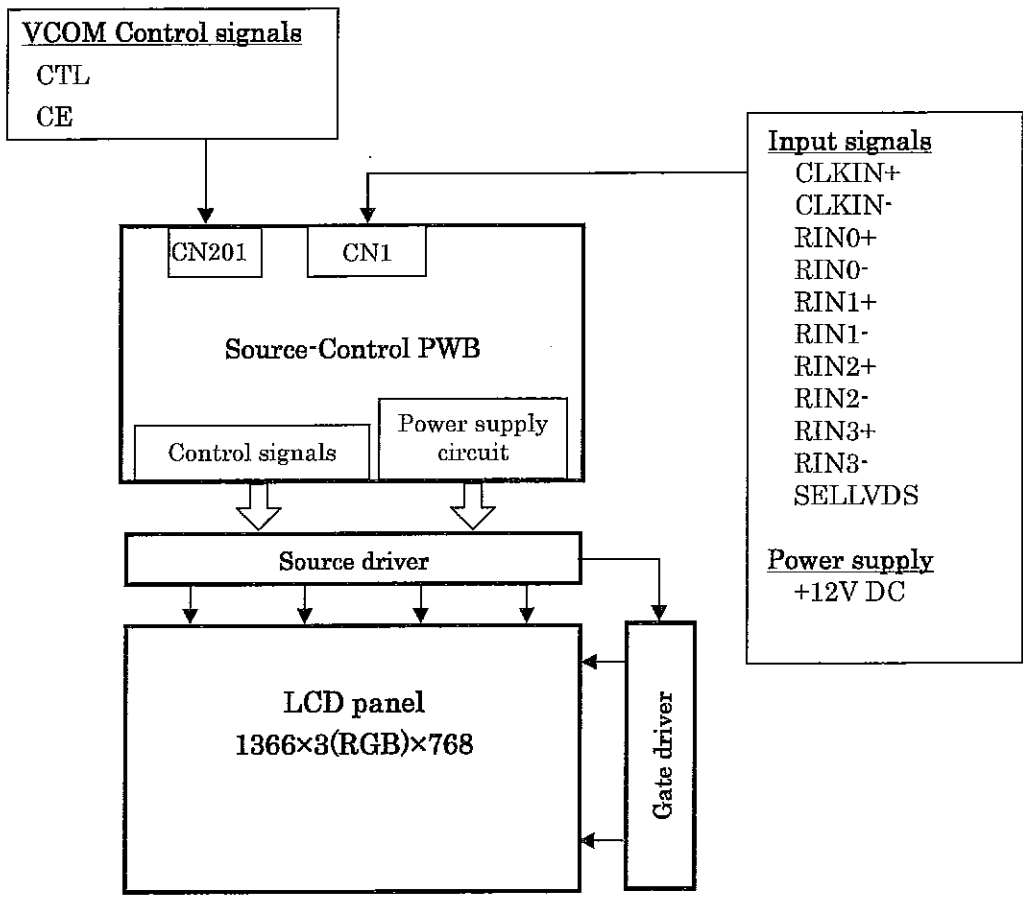
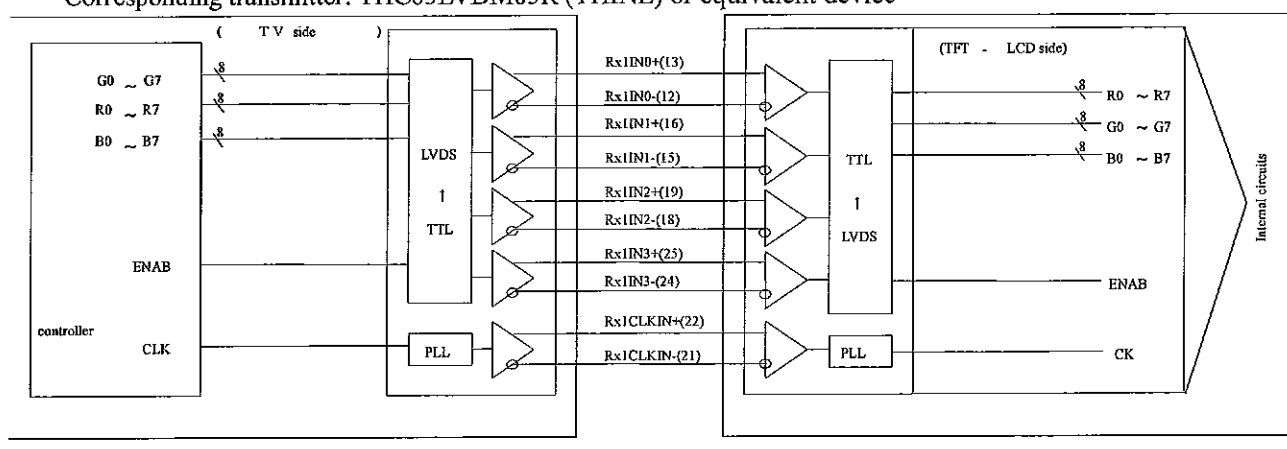
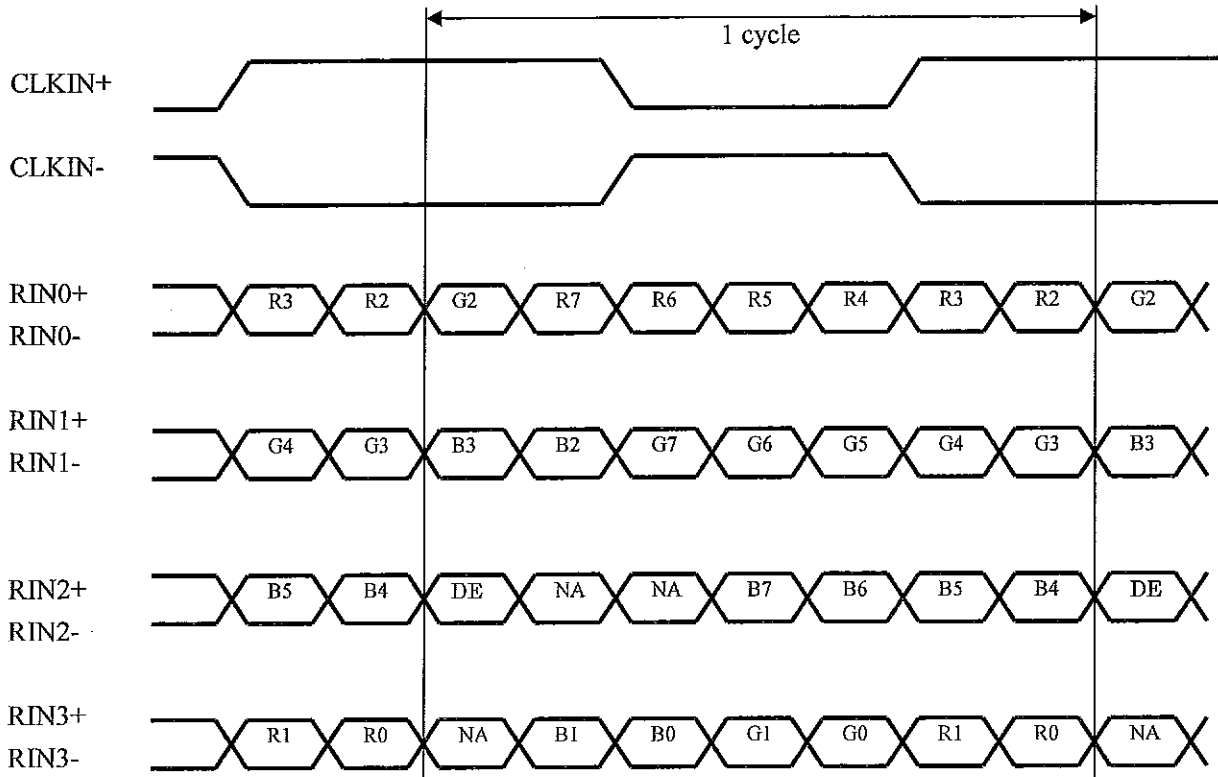

Fig.1 Interface block diagram



LD-K22562-5

**SELLVDS= High (3.3V)**



**SELLVDS= Low (GND) or Open**

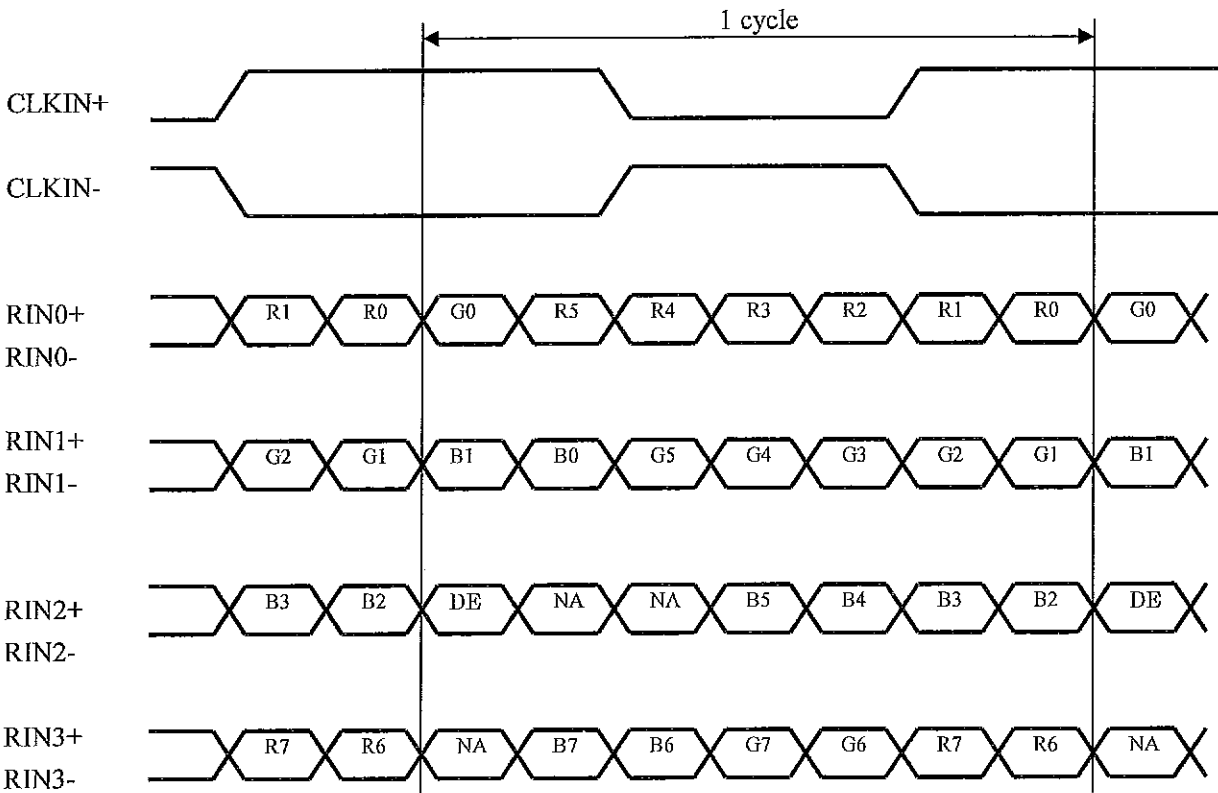

DE: Display Enable

NA: Not Available (Fixed Low)

#### 4.2. Vcom Adjusting interface of Source-Control PWB

CN201 (Interface Vcom Adjusting) in Source-Control PWB

Using Via Hole : 1.5mm Pitch (  $\phi$  0.7mm )

Mated connector : (housing) 5P-SZN, (contact) SZN-002T-P0.7K (JST Co., Ltd.)

Communication method: Pulse control method

Pin No.	Symbol	Function	Remark
1	NC	-	
2	NC	-	
3	GND	Signal GND	
4	CTL	Control Signal [Note1]	
5	CE	Chip Enable [Note1]	Pull down to GND [Note2]

[Note1] Refer to specifications of MAX1512 (MAXIM) for Vcom adjustment.

You should adjust a flicker to be minimized in below pattern, where the gray level of “0” and “127” are displayed alternately at every subpixel, otherwise images may be remained on the screen.

[Note2] The equivalent circuit figure of the terminal is as below:

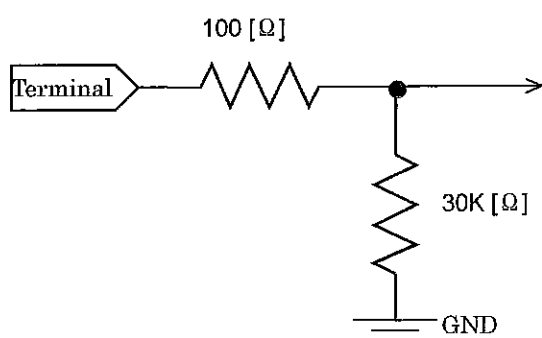

Equivalent circuit of CE terminal

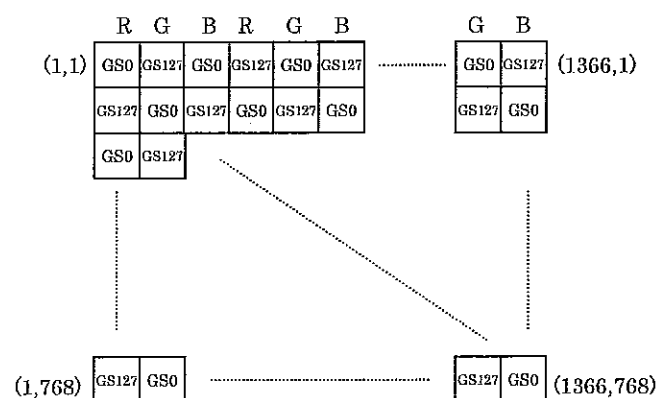

Flicker-Check Pattern

#### 4.3. Absolute maximum ratings

Parameter	Symbol	Condition	Ratings	Unit	Remark
Input voltage (for Source-Control PWB)	$V_I$	$T_a=25^\circ\text{C}$	-0.3 ~ 3.6	V	[Note 1]
+12V supply voltage (for Source-Control PWB)	$V_{CC}$	$T_a=25^\circ\text{C}$	0 ~ +15	V	
Vcom control voltage	$V_{CTL}$	$T_a=25^\circ\text{C}$	-0.3 ~ +16	V	
Chip enable Voltage	$V_{CE}$	$T_a=25^\circ\text{C}$	-0.3 ~ +4	V	
Storage temperature	$T_{stg}$	-	-25 ~ +60	$^\circ\text{C}$	[Note 2]
Operation temperature (Ambient)	$T_{opa}$	-	0 ~ +50	$^\circ\text{C}$	

[Note 1] SELVDS

[Note 2] Humidity 95%RH Max.( $T_a \leq 40^\circ\text{C}$ )

Maximum wet-bulb temperature is  $39^\circ\text{C}$  or less ( $T_a > 40^\circ\text{C}$ ). No condensation.



## 4.4. Electrical characteristics of input signals

Ta=25°C

Parameter		Symbol	Min.	Typ.	Max.	Unit	Remark
+12V supply voltage	Supply voltage	$V_{CC}$	+11.4	+12.0	+12.6	V	[Note 1]
	Current consumption	$I_{CC}$	-	330	600	mA	[Note 2]
		$I_{RUSH}$	-	1100	2500	mA	[Note 5]
		$T_{RUSH}$	-	0.5	-	ms	[Note 5]
Permissible input ripple voltage		$V_{RP}$	-	-	100	mV <sub>P-P</sub>	$V_{CC} = +12.0V$
Differential input threshold voltage	High	$V_{TH}$	-	-	100	mV	* $V_{CM} = +1.2V$ [Note 4]
	Low	$V_{TL}$	-100	-	-	mV	
Input low voltage		$V_{IL}$	0	-	0.7	V	[Note 3]
Input high voltage		$V_{IH}$	2.6	-	3.3	V	
Input leak current (Low)		$I_{IL}$	-	-	400	$\mu A$	$V_I = 0V$ [Note 3]
Input leak current (High)		$I_{IH}$	-	-	100	$\mu A$	$V_I = 3.3V$ [Note 3]
Terminal resistor		$R_T$	-	100	-	$\Omega$	Differential input

[Note] \* $V_{CM}$ : Common mode voltage of LVDS driver.

[Note 1]

Input voltage sequences

$$50\mu s < t_1 \leq 20ms$$

$$20ms < t_2-1$$

$$20ms < t_2-2$$

$$0 < t_3 \leq 1s$$

$$t_4 \geq 1s$$

$$t_5 \geq 300ms$$

Dip conditions for supply voltage

a)  $9.1V \leq V_{CC} < 10.8V$

$$t_d \leq 10ms$$

b)  $V_{CC} < 9.1V$

Dip conditions for supply voltage is

based on input voltage sequence.

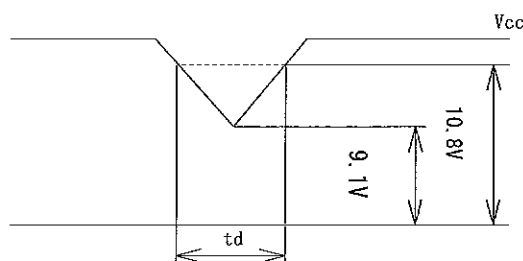
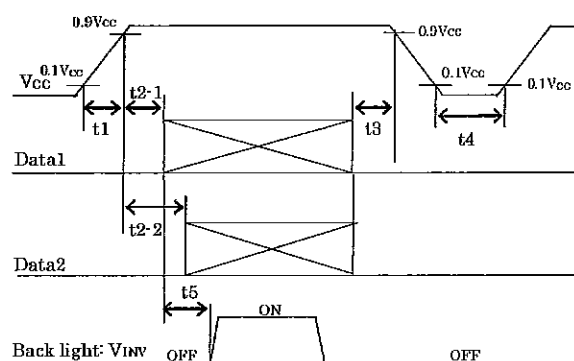
※ Data1: CLKIN $\pm$ , RIN0 $\pm$ , RIN1 $\pm$ , RIN2 $\pm$ , RIN3 $\pm$ 

※ Data2: SELLVDS

※ About the relation between data input and back light lighting, we recommend the above-mentioned input sequence.

If the back light is switched on before a panel operation begins or after a panel operation stops, the screen may not be displayed properly. But this phenomenon is not caused by change of an incoming signal, and does not give damage to a liquid crystal display.

[Note 2] Typical current situation: 256 gray-bar pattern ( $V_{CC} = +12.0V$ )

The explanation of RGB gray scale is seen in section 8.

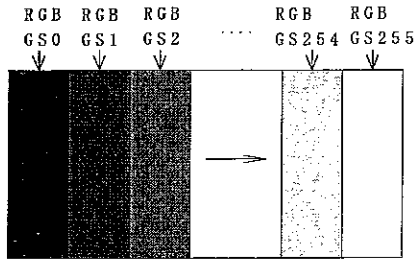

$V_{CC} = +12.0V$   
 $CK = 82.0MHz$   
 $Th = 20.68\mu s$

[Note 3] SELLVDS

[Note 4] CLKIN+/CLKIN-, RIN0+/RIN0-, RIN1+/RIN1-, RIN2+/RIN2-, RIN3+/RIN3-

[Note 5] The rush current corrugation at the time of power on

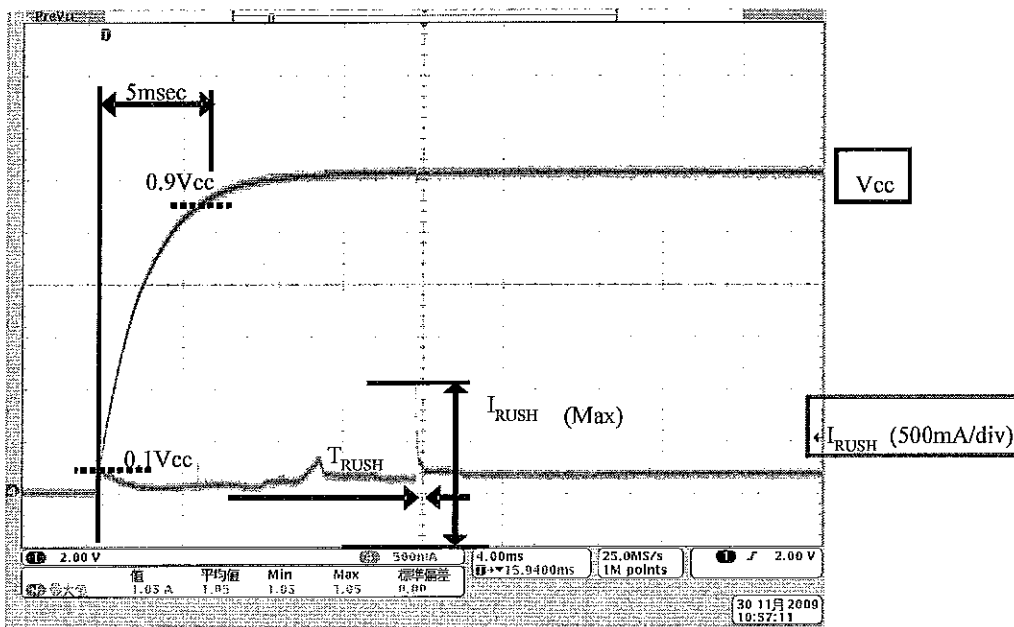

4ms/div

#### 4.5. Timing characteristics of input signals

Timing diagrams of input signal are shown in Fig.2

Parameter		Symbol	Min.	Typ.	Max.	Unit
Clock	Frequency	1/Tc	72	82	85	MHz
Data enable signal	Horizontal period	TH	1540	1696	1940	clock
			19.84	20.68	-	$\mu$ s
	Horizontal period (High)	THd	1366	1366	1366	clock
	Vertical period	TV	778	806	972	line
	Vertical period (High)	TVd	768	768	768	line

[Note] \*When a vertical period is very long, a flicker may occur.

\*Please turn off the module after it shows the black screen.

\*Please make sure that a length of vertical period should be an integral multiple of horizontal period, otherwise the screen may not display properly.

\*Please be careful not to fall below the minimum horizontal period, otherwise the display may be dark.

We will check the display operation for your final setting of drive timing, so please inform us of your final setting.

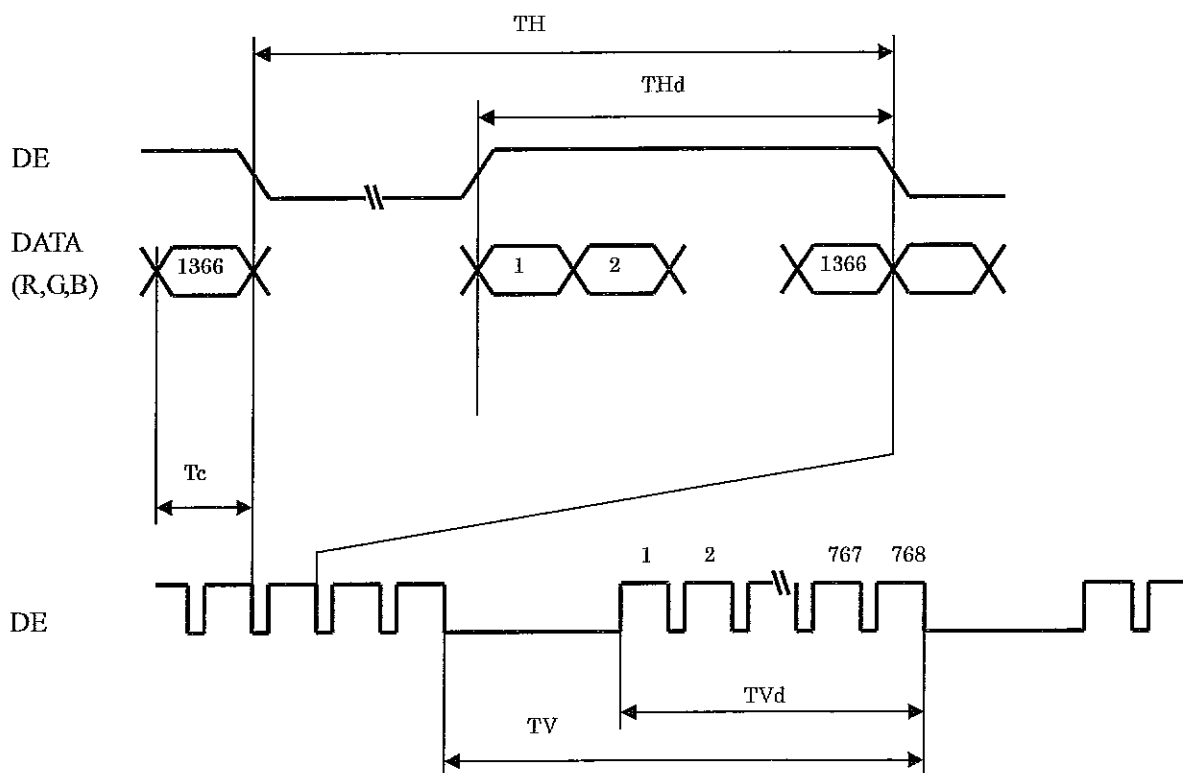
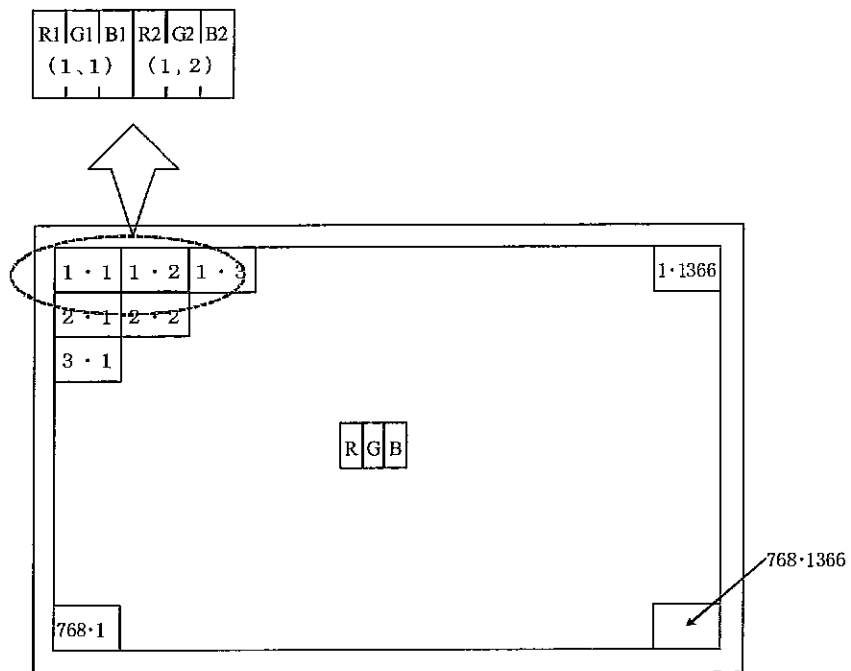

Fig.2 Timing diagram of input signals



### 4.6. Display position on the screen



Display Position of Data (V,H)

5. Input signal, basic display colors and gray scale of each color

	Colors & Gray scale	Data signal																								
		Gray Scale	R0	R1	R2	R3	R4	R5	R6	R7	G0	G1	G2	G3	G4	G5	G6	G7	B0	B1	B2	B3	B4	B5	B6	B7
Basic Color	Black	—	0	0	0	0	0	0	0	0	0	0	0	0	0	0	0	0	0	0	0	0	0	0	0	0
	Blue	—	0	0	0	0	0	0	0	0	0	0	0	0	0	0	0	0	1	1	1	1	1	1	1	1
	Green	—	0	0	0	0	0	0	0	0	1	1	1	1	1	1	1	1	0	0	0	0	0	0	0	0
	Cyan	—	0	0	0	0	0	0	0	0	1	1	1	1	1	1	1	1	1	1	1	1	1	1	1	1
	Red	—	1	1	1	1	1	1	1	1	0	0	0	0	0	0	0	0	0	0	0	0	0	0	0	0
	Magenta	—	1	1	1	1	1	1	1	1	0	0	0	0	0	0	0	0	1	1	1	1	1	1	1	1
	Yellow	—	1	1	1	1	1	1	1	1	1	1	1	1	1	1	1	1	0	0	0	0	0	0	0	0
	White	—	1	1	1	1	1	1	1	1	1	1	1	1	1	1	1	1	1	1	1	1	1	1	1	1
Gray Scale of Red	Black	GS0	0	0	0	0	0	0	0	0	0	0	0	0	0	0	0	0	0	0	0	0	0	0	0	0
	↑	GS1	1	0	0	0	0	0	0	0	0	0	0	0	0	0	0	0	0	0	0	0	0	0	0	0
	Darker	GS2	0	1	0	0	0	0	0	0	0	0	0	0	0	0	0	0	0	0	0	0	0	0	0	0
	↑	↓					↓							↓								↓				
	↓	↓					↓							↓								↓				
	Brighter	GS253	1	0	1	1	1	1	1	1	0	0	0	0	0	0	0	0	0	0	0	0	0	0	0	0
	↓	GS254	0	1	1	1	1	1	1	1	0	0	0	0	0	0	0	0	0	0	0	0	0	0	0	0
	Red	GS255	1	1	1	1	1	1	1	1	0	0	0	0	0	0	0	0	0	0	0	0	0	0	0	0
Gray Scale of Green	Black	GS0	0	0	0	0	0	0	0	0	0	0	0	0	0	0	0	0	0	0	0	0	0	0	0	0
	↑	GS1	0	0	0	0	0	0	0	0	1	0	0	0	0	0	0	0	0	0	0	0	0	0	0	0
	Darker	GS2	0	0	0	0	0	0	0	0	0	1	0	0	0	0	0	0	0	0	0	0	0	0	0	0
	↑	↓					↓							↓								↓				
	↓	↓					↓							↓								↓				
	Brighter	GS253	0	0	0	0	0	0	0	0	1	0	1	1	1	1	1	1	0	0	0	0	0	0	0	0
	↓	GS254	0	0	0	0	0	0	0	0	0	1	1	1	1	1	1	1	0	0	0	0	0	0	0	0
	Green	GS255	0	0	0	0	0	0	0	0	1	1	1	1	1	1	1	1	0	0	0	0	0	0	0	0
Gray Scale of Blue	Black	GS0	0	0	0	0	0	0	0	0	0	0	0	0	0	0	0	0	0	0	0	0	0	0	0	0
	↑	GS1	0	0	0	0	0	0	0	0	0	0	0	0	0	0	0	0	1	0	0	0	0	0	0	0
	Darker	GS2	0	0	0	0	0	0	0	0	0	0	0	0	0	0	0	0	0	1	0	0	0	0	0	0
	↑	↓					↓							↓								↓				
	↓	↓					↓							↓								↓				
	Brighter	GS253	0	0	0	0	0	0	0	0	0	0	0	0	0	0	0	0	1	0	1	1	1	1	1	1
	↓	GS254	0	0	0	0	0	0	0	0	0	0	0	0	0	0	0	0	0	1	1	1	1	1	1	1
	Blue	GS255	0	0	0	0	0	0	0	0	0	0	0	0	0	0	0	0	1	1	1	1	1	1	1	1

0: Low level voltage                      1: High level voltage

Each basic color can be displayed in 256 gray scales from 8 bit data signals. According to the combination of total 24 bit data signals, the 16,777,216 colors can be displayed on the screen.

## 6. Optical characteristics

$T_a = 25^\circ\text{C}$ ,  $V_{CC} = +12\text{V}$ ,  $V_{INV} = +24\text{V}$

Parameter	Symbol	Condition	Min.	Typ.	Max.	Unit	Remark		
Viewing angle range	Horizontal $\theta_{21}$ $\theta_{22}$	CR $\geq$ 10	70	88	-	Deg.	[Note1,4]		
			Vertical $\theta_{11}$ $\theta_{12}$	70	88	-		Deg.	
Contrast ratio	CRn	2000		2500	-	-	[Note2,4] $V_{BRT}=3.15\text{V}$		
Response time	$\tau_{DRV}$		-	6	-	ms	[Note3,4,5] $V_{BRT}=3.15\text{V}$		
Chromaticity of white	x	$\theta=0$ deg.	Typ.-0.03	0.278	Typ.+0.03	-	[Note 4] $V_{BRT}=3.15\text{V}$		
	y		Typ.-0.03	0.285	Typ.+0.03	-			
Chromaticity of red	x		Typ.-0.03	0.642	Typ.+0.03	-			
	y		Typ.-0.03	0.344	Typ.+0.03	-			
Chromaticity of green	x		Typ.-0.03	0.280	Typ.+0.03	-			
	y		Typ.-0.03	0.606	Typ.+0.03	-			
Chromaticity of blue	x		Typ.-0.03	0.143	Typ.+0.03	-			
	y		Typ.-0.03	0.075	Typ.+0.03	-			
Luminance of white	$Y_L$			360	450			cd/m <sup>2</sup>	[Note 4] $V_{BRT}=3.15\text{V}$
Luminance uniformity	$\delta_w$			-	-	1.25		-	[Note 6]
Transmittance	T				4.7			%	[Note 4,7]

\*Optical characteristics are based on SHARP standard CCFL module.

\*The measurement shall be executed 60 minutes after turning on.

[Note] The optical characteristics are measured using the following equipment.

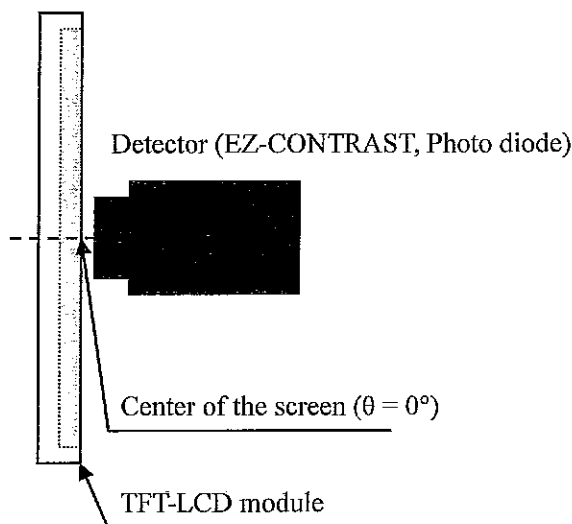

Fig.3-1 Measurement of viewing angle range and response time.

(Viewing angle range: EZ-CONTRAST  
Response time: Photo diode)

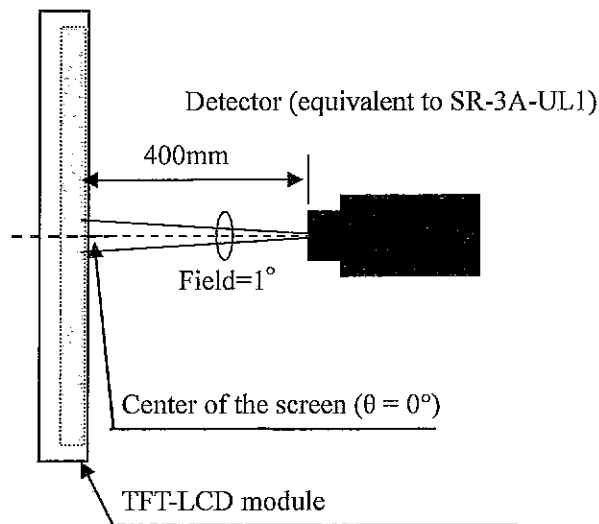
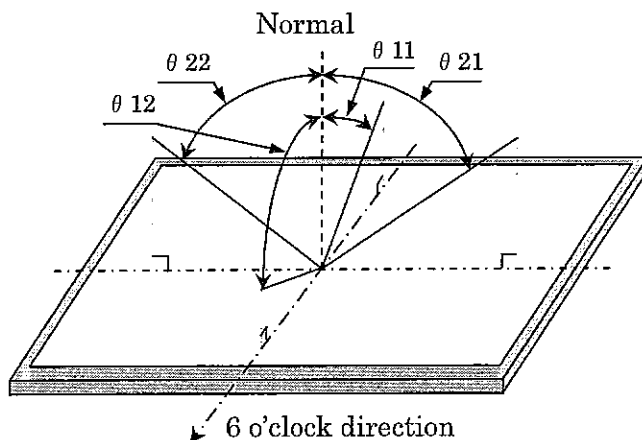

Fig.3-2 Measurement of Contrast, Luminance, and Chromaticity.

[Note 1] Definitions of viewing angle range:



[Note 2] Definition of contrast ratio:

The contrast ratio is defined as the following.

$$\text{Contrast ratio} = \frac{\text{Luminance (brightness) with all pixels white}}{\text{Luminance (brightness) with all pixels black}}$$

[Note 3] Definition of response time

The response time ( $\tau_{DRV}$ ) is defined as the following equation and shall be measured by switching the input signal from “any level of gray (0%, 25%, 50%, 75% and 100%)” to “any level of gray (0%, 25%, 50%, 75% and 100%)”.

	0%	25%	50%	75%	100%
0%		tr: 0%-25%	tr: 0%-50%	tr: 0%-75%	tr: 0%-100%
25%	td: 25%-0%		tr: 25%-50%	tr: 25%-75%	tr: 25%-100%
50%	td: 50%-0%	td: 50%-25%		tr: 50%-75%	tr: 50%-100%
75%	td: 75%-0%	td: 75%-25%	td: 75%-50%		tr: 75%-100%
100%	td: 100%-0%	td: 100%-25%	td: 100%-50%	td: 100%-75%	

$$\tau_{DRV} = \Sigma(t^*:x-y)/20$$

t\*:x-y...response time from level of gray(x) to gray(y)

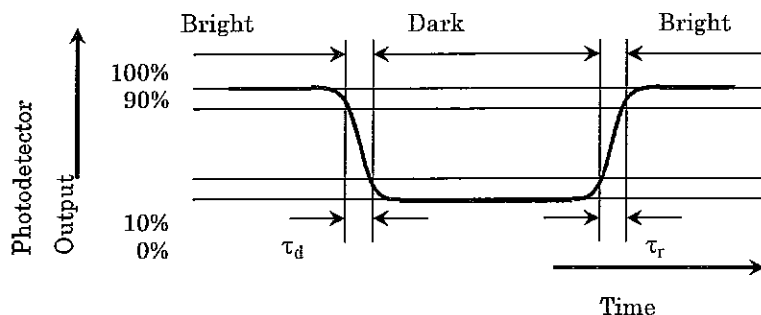

Fig.4 Response time of fall ( $\tau_d$ ) and rise ( $\tau_r$ )

[Note 4] This shall be measured at center of the screen.

[Note 5] This value is valid when O/S driving is used at typical input timing.

[Note 6] Definition of white uniformity;

White uniformity is defined as the following with five measurements. (A~E)

$$\delta w = \frac{\text{Maximum luminance of five points (brightness)}}{\text{Minimum luminance of five points (brightness)}}$$

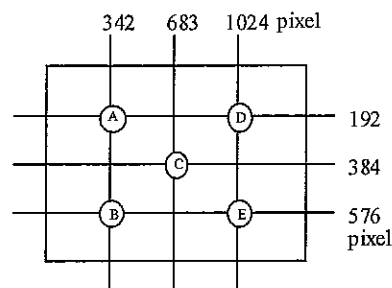

[Note 7] Definition of Transmittance

Transmittance is defined as following

$$T = \frac{\text{Luminance of LCD (brightness)}}{\text{Luminance of Back Light (brightness)}} \times 100$$

## 7. Packing for shipping

### 7.1 Packing form

- a) Open Cell quantity in 1 cell box : 10pcs
- b) Piling number of cell box : 140 Maximum
- c) 1 cell box size : 1165 (W) x 875 (D) x 879 (H) [mm]
- d) Total mass of 1 cell filled with full open cells : 7.0 kg Maximum

[Note] Please refer to the attached drawing for details.

This Packing form is for only domestic transport.

### 7.2 Label

- a) Open Cell Label (Size: 45mm(H) x 20mm(V) )

This label is stuck on the protection film of front polarizer.

ex) LK315T3HA39

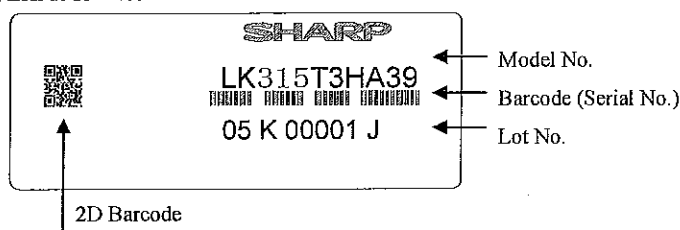

How to express Lot No.

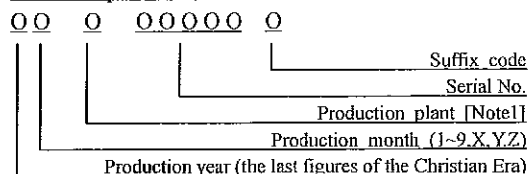

[Note1] Production plant code

Code	Plant	Model No. & Suffix Code

- b) Packing label (Size: 80mm(H) x 60mm(V) )



This label is stuck on the cell box and palette.

ex) LK315T3HA39

社内品番 : (4S) LK315T3HA39	
Barcode(①)	
Lot NO. : (1T) 2010. * **	
Barcode(②)	
Quantity : (Q) * pcs	
Barcode(③)	
ユーザ品番 :	
シャープ物置用ラベルです。	

① Model No.& Suffix Code

② Lot No.

③ Quantity

## 8. Carton storage condition

Temperature 0°C to 40°C

Humidity 95%RH or less

Reference condition : 20°C to 35°C , 85%RH or less (summer)

: 5°C to 15°C , 85%RH or less (winter)

• the total storage time (40°C,95%RH) : 240H or less

Sunlight Be sure to shelter a product from the direct sunlight.

Atmosphere Harmful gas, such as acid and alkali which bites electronic components and/or wires must not be detected.

Notes Be sure to put cartons on palette or base, don't put it on floor, and store them with removing from wall

Please take care of ventilation in storehouse and around cartons, and control changing temperature is within limits of natural environment

Storage life 1 year

## 9. Reliability

Reliability test item:

No.	Test item	Condition
1	High temperature storage test	Ta=60°C 240h
2	Low temperature storage test	Ta=-25°C 240h
3	High temperature and high humidity operation test	Ta=40°C ; 95%RH 240h (No condensation)
4	High temperature operation test	Ta=50°C 240h
5	Low temperature operation test	Ta=0°C 240h

Above tests are executed under the CCFL module conditions.

## 10. Precautions

- a) Because the Open-Cell is weak to static electricity, please do not touch the terminal with bare hands.
- b) Since the front polarizer is easily damaged, pay attention not to scratch it.
- c) Since long contact with drops of water may cause discoloration or spots, please wipe off them as soon as put on the screen.
- d) When the panel surface is soiled, wipe it with absorbent cotton or other soft cloth.
- e) Since the panel is made of glass, it may break or crack if dropped or bumped on hard surface. Handle with care.
- f) Precautions of peeling off the protection film:
  - Be sure to peel off slowly (recommended more than 7sec) and constant speed.
  - Peeling direction shown in Fig. 5.
  - Be sure to ground person with adequate methods such as the anti-static wrist band.
  - Be sure to ground S-PWBs while peeling off the protection film.
  - Ionized air should be blown to the surface while peeling off.
  - The protection film must not touch drivers and S-PWBs.
  - If adhesive may remain on the polarizer after the protection film peeled off, please remove with isopropyl-alcohol.

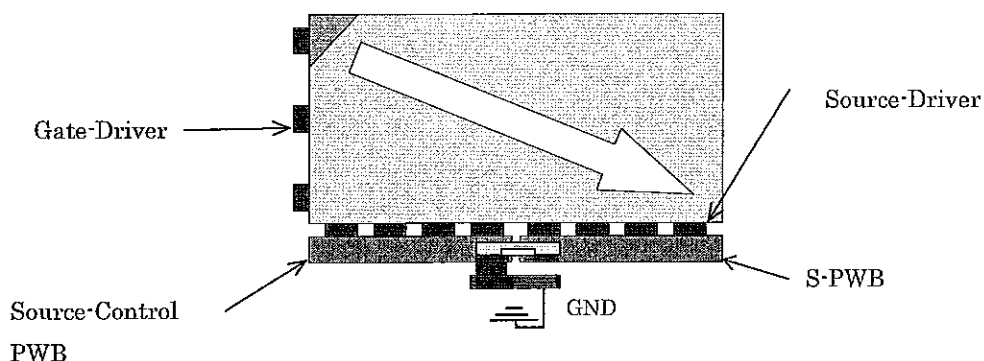

Fig.5 Direction of peeling off

- g) Since the Open-Cell consists of TFT and electronic circuits with CMOS-ICs, which are very weak to electrostatic discharge, persons who are handling a Open-Cell should be grounded through adequate methods such as an anti-static wrist band. Connector pins should not be touched directly with bare hands.

·Reference: Process control standard of sharp

	item	Management standard value and performance standard
1	Anti-static mat(shelf)	1 to 50 [Mega ohm]
2	Anti-static mat(floor, desk)	1 to 100 [Mega ohm]
3	Ionizer	Attenuate from $\pm 1000V$ to $\pm 100V$ within two seconds.
4	Anti-static wrist band	0.8 to 10 [Mega ohm]
5	Anti-static wrist band entry and ground resistance	Below 1000 [ohm]
6	Temperature	22 to 26 [°C]
7	Humidity	60 to 70 [%]

- h) Since the Open-Cell has some PWBs, please take care to keep them off any stress or pressure when handling or installing the Open-Cell, otherwise some of electronic parts on them may be damaged.
- i) Be sure to turn off the power supply when inserting or disconnecting the cable.
- j) Be sure to design the module and cabinet so that the Open-Cell can be installed without any extra stress such as warp or twist.

LD-K22562-17

- k) When handling and assembling Open-Cells into module and cabinets, please be noted that long-term storage in the environment of oxidization or deoxidization gas and the use of materials such as reagent, solvent, adhesive, resin, etc. which generate these gasses, may cause corrosion and discoloration of the Open-Cell.
- l) Applying too much force and stress to PWBs and drivers may cause a malfunction electrically and mechanically.
- m) The Open-Cell has high frequency circuits. Sufficient suppression to EMI should be done by system manufactures.
- n) Please be careful since image retention may occur when a fixed pattern is displayed for a long time.
- o) The chemical compound, which causes the destruction of ozone layer, is not being used.
- p) This Open-Cell module is corresponded to RoHS.
- q) When any question or issue occurs, it shall be solved by mutual discussion.

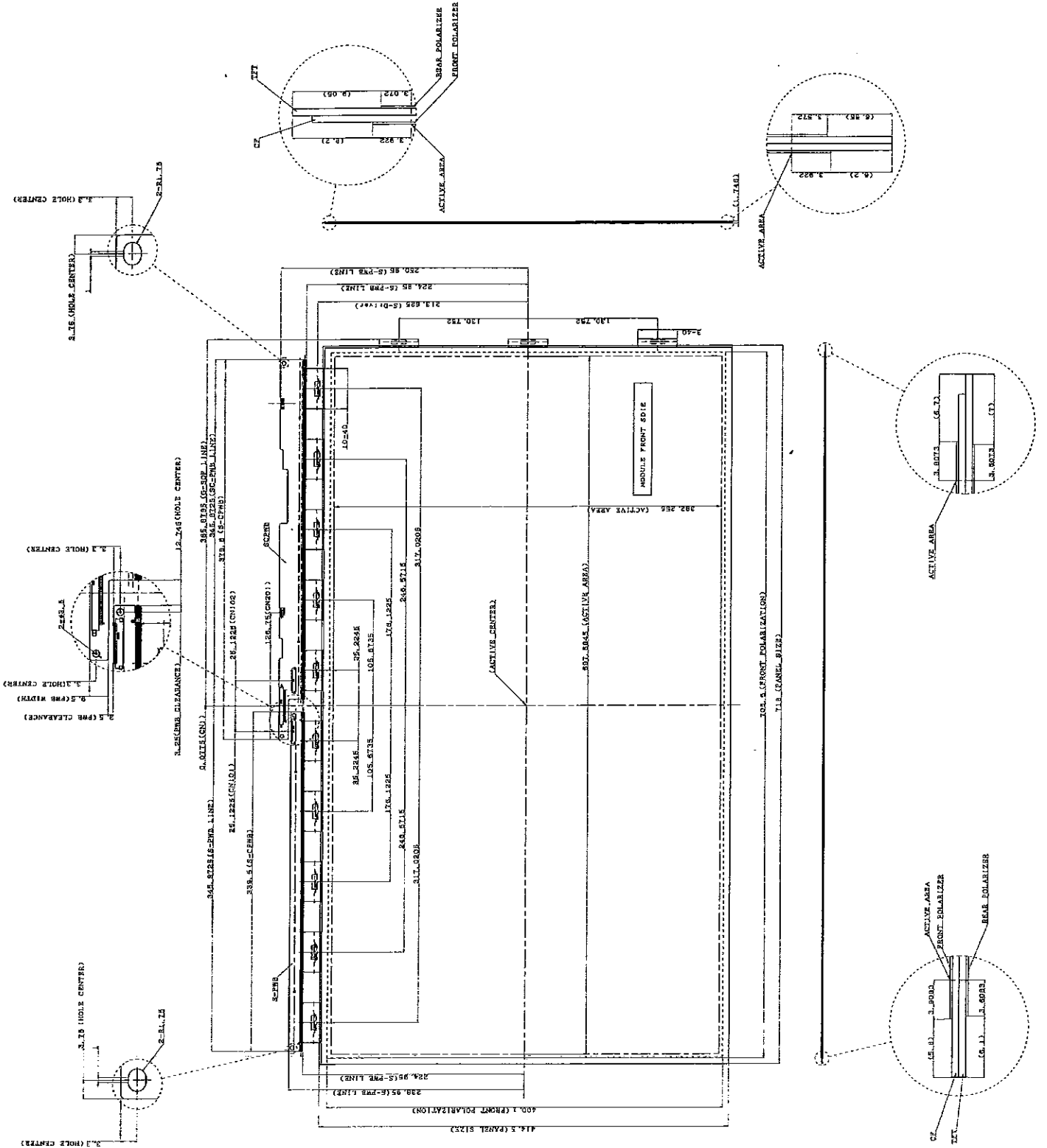

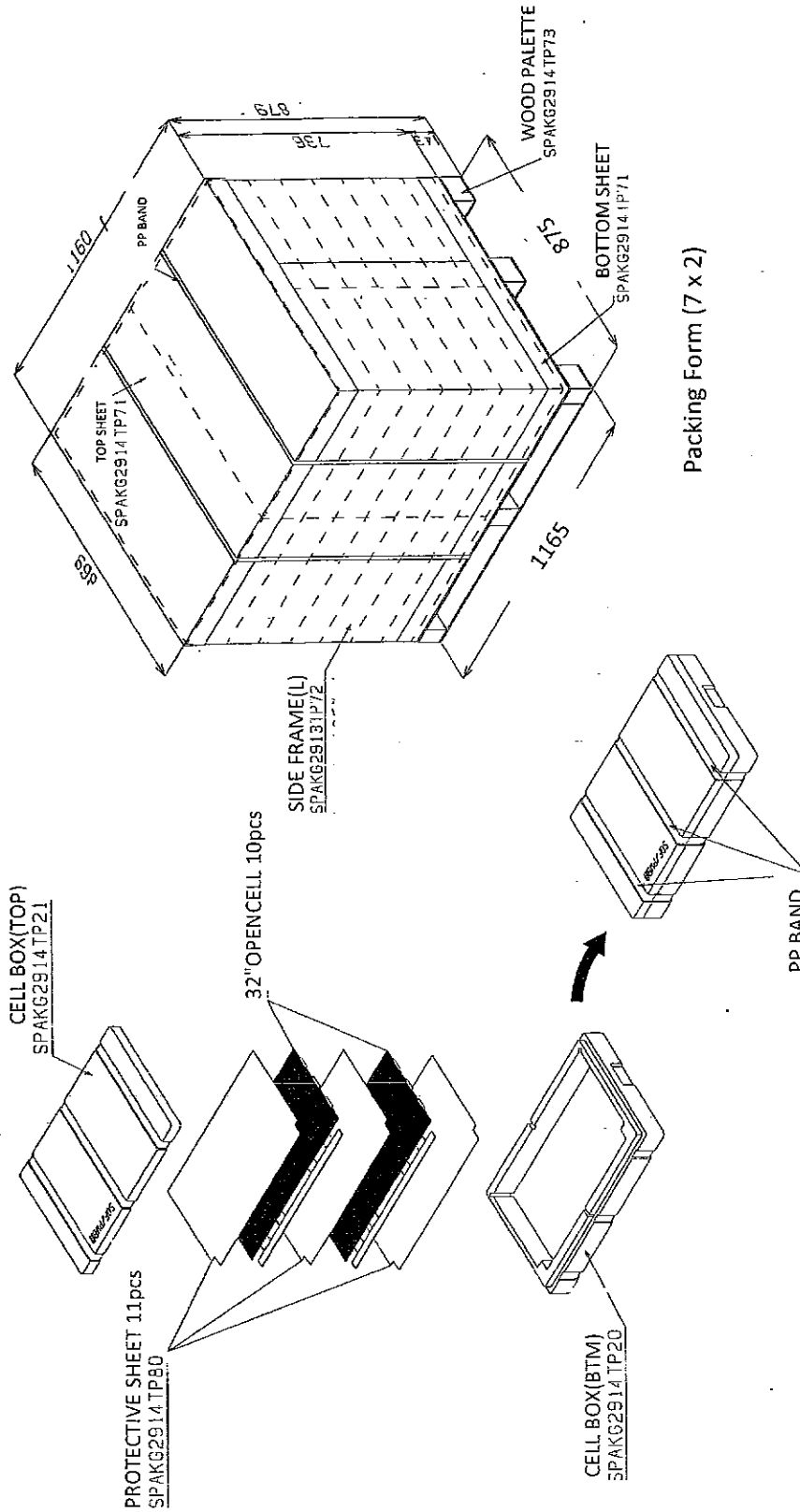

### 32 INCH OPENCELL Packing Form