

PREPARED BY : DATE	<b>SHARP</b>  LIQUID CRYSTAL DISPLAY GROUP SHARP CORPORATION <b>SPECIFICATION</b>	SPEC No. LD-K22332C
APPROVED BY : DATE		PAGE 22pages
		ISSUE: January, 31, 2011
		APPLICABLE GROUP LIQUID CRYSTAL DISPLAY DISPLAY DIVISION I

DEVICE SPECIFICATION FOR

TFT-LCD Open Cell

MODEL No. LK400D3HA14

CUSTOMERS APPROVAL

DATE \_\_\_\_\_

BY \_\_\_\_\_

BY A. Fujisawa

A.Fujisawa

GENERAL MANAGER

LIQUID CRYSTAL DISPLAY DIVISION I

LIQUID CRYSTAL DISPLAY GROUP

SHARP CORPORATION

## 1 Application

This specification applies to the color 40.0" TFT-LCD Open Cell LK400D3HA14

(With parts in surrounding(C-PWB,FPC) to drive it.)

- \* These specification are proprietary products of SHARP CORPORATION ("SHARP") and include materials protected under copyright of SHARP. Do not reproduce or cause any third party to reproduce them in any form or by any means, electronic or mechanical, for any purpose, in whole or in part, without the express written permission of SHARP.
- \* In case of using the device for applications such as control and safety equipment for transportation (aircraft, trains, automobiles, etc.), rescue and security equipment and various safety related equipment which require higher reliability and safety, take into consideration that appropriate measures such as fail-safe functions and redundant system design should be taken.
- \* Do not use the device for equipment that requires an extreme level of reliability, such as aerospace applications, telecommunication equipment (trunk lines), nuclear power control equipment and medical or other equipment for life support.
- \* SHARP assumes no responsibility for any damage resulting from the use of the device that does not comply with the instructions and the precautions specified in these specification.
- \* Contact and consult with a SHARP sales representative for any questions about this device.

## 2 Overview

This Open Cell (LK400D3HA14) is a color active matrix LCD incorporating amorphous silicon TFT (Thin Film Transistor). It is composed of a color TFT-LCD panel, driver ICs and Source PWB. Graphics and texts can be displayed on a  $1920 \times \text{RGB} \times 1080$  dots panel by using LVDS (Low Voltage Differential Signaling) for the interface of a special timing control substrate.

The content of this specifications can be filled by using C-PWB (LK0DZ1C0089(RUNTK4224TPZD)) and FPC (LK0DZ1C0112) of the Sharp specification. This C-PWB applies the Over Shoot driving (O/S driving) technology in order to improve the response time of LCD. In the O/S driving technology, signals are being applied to the Liquid Crystal according to a pre-fixed process as an image signal of the present frame when a difference is found between image signal of the previous frame and that of the current frame after comparing them.

With combination of these technologies, motion blur can be reduced and clearer display performance can be realized.

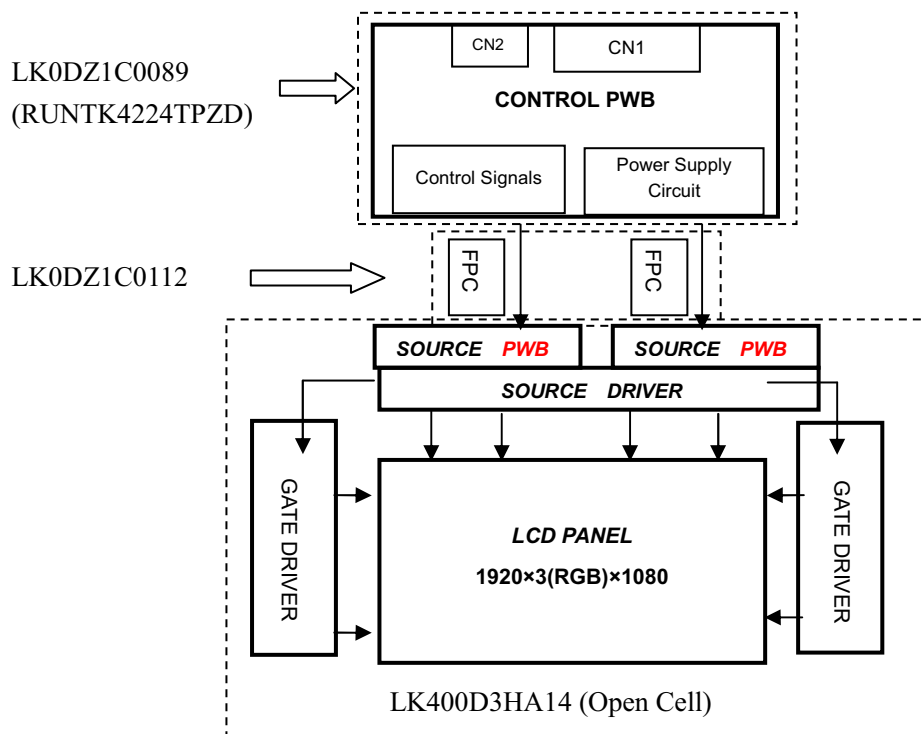

### 3 Mechanical Specifications ▲C

Parameter	Specifications	Unit
Display size	101.609 (Diagonal)	cm
	40.0 (Diagonal)	inch
Active area	885.6(H) x 498.15 (V)	mm
Pixel Format	1920(H) x 1080(V) (1pixel = R + G + B dot)	pixel
Pixel pitch	461.25(H) x 461.25 (V)	um
Pixel configuration	R, G, B vertical stripe	
Display mode	Normally black	
Outline Dimensions with SOF and PWB [Note 1]	921.18(H) x 548.55(V) x 3.5(D)	mm
Cell Outline Dimensions	908.6(H) x 515.7(V) x 1.8(D)	mm
Mass	1.88 ±0.3	kg
Surface treatment [Note 2] (Upper Polarizing film)	Low-Haze Anti Glare Hard coating : 2H and more	
Surface treatment [Note 2] (Lower Polarizing film)	Plain	

[Note 1] Outline dimensions are shown in page19

[Note 2] With the protection film removed.

## 4 Cell Driving Specifications

### 4.1 Driving interface of Control PWB SHARP specifies [LK0DZ1C0089(RUNTK4224TPZD)]

CN1 (Interface signals and +12V DC power supply) (Shown in Fig1)

Using connector : FI-RE51S-HF (Japan Aviation Electronics Ind., Ltd.)

Matching connector : FI-RE51HL, FI-RE51CL (Japan Aviation Electronics Ind., Ltd.) device

Matching LVDS transmitter : THC63LVD1023 or equivalent device

Pin No.	Symbol	Function	Remark
1	GND		
2	Reserved	It is required to set non-connection(OPEN)	
3	Reserved	It is required to set non-connection(OPEN)	
4	Reserved	It is required to set non-connection(OPEN)	
5	Reserved	It is required to set non-connection(OPEN)	
6	Reserved	It is required to set non-connection(OPEN)	
7	SELLVDS	Select LVDS data order [Note1,2]	Pull up : 3.3V
8	Reserved	It is required to set non-connection(OPEN)	
9	Reserved	It is required to set non-connection(OPEN)	
10	FRAME	Frame frequency setting 1:50Hz 0:60Hz [Note3] ▲C	Pull down :GND
11	GND		
12	AIN0-	Aport (-)LVDS CH0 differential data input	
13	AIN0+	Aport (+)LVDS CH0 differential data input	
14	AIN1-	Aport (-)LVDS CH1 differential data input	
15	AIN1+	Aport (+)LVDS CH1 differential data input	
16	AIN2-	Aport (-)LVDS CH2 differential data input	
17	AIN2+	Aport (+)LVDS CH2 differential data input	
18	GND		
19	ACK-	Aport LVDS Clock signal(-)	
20	ACK+	Aport LVDS Clock signal(+)	
21	GND		
22	AIN3-	Aport (-)LVDS CH3 differential data input	
23	AIN3+	Aport (+)LVDS CH3 differential data input	
24	AIN4-	Aport (-)LVDS CH4 differential data input	
25	AIN4+	Aport (+)LVDS CH4 differential data input	
26	GND		
27	GND		
28	BIN0-	Bport (-)LVDS CH0 differential data input	
29	BIN0+	Bport (+)LVDS CH0 differential data input	
30	BIN1-	Bport (-)LVDS CH1 differential data input	
31	BIN1+	Bport (+)LVDS CH1 differential data input	
32	BIN2-	Bport (-)LVDS CH2 differential data input	
33	BIN2+	Bport (+)LVDS CH2 differential data input	
34	GND		
35	BCK-	Bport LVDS Clock signal(-)	
36	BCK+	Bport LVDS Clock signal(+)	
37	GND		
38	BIN3-	Bport (-)LVDS CH3 differential data input	
39	BIN3+	Bport (+)LVDS CH3 differential data input	
40	BIN4-	Bport (-)LVDS CH4 differential data input	
41	BIN4+	Bport (+)LVDS CH4 differential data input	
42	GND		
43	GND		
44	GND		
45	GND		
46	GND		
47	VCC	+12V Power Supply	
48	VCC	+12V Power Supply	
49	VCC	+12V Power Supply	
50	VCC	+12V Power Supply	
51	VCC	+12V Power Supply	

[Note 1] The equivalent circuit figure of the terminal ▲C

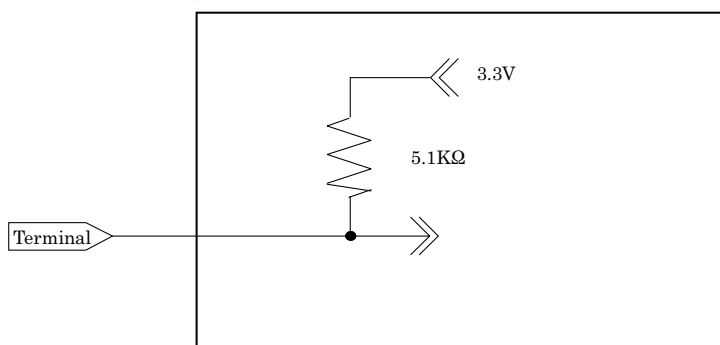

[Note 2] LVDS Data order

SELLVDS		
Data	L(GND) VESA	H(3.3V) or Open JEIDA
TA0	R0(LSB)	R4
TA1	R1	R5
TA2	R2	R6
TA3	R3	R7
TA4	R4	R8
TA5	R5	R9(MSB)
TA6	G0(LSB)	G4
TB0	G1	G5
TB1	G2	G6
TB2	G3	G7
TB3	G4	G8
TB4	G5	G9(MSB)
TB5	B0(LSB)	B4
TB6	B1	B5
TC0	B2	B6
TC1	B3	B7
TC2	B4	B8
TC3	B5	B9(MSB)
TC4	NA	NA
TC5	NA	NA
TC6	DE(*)	DE(*)
TD0	R6	R2
TD1	R7	R3
TD2	G6	G2
TD3	G7	G3
TD4	B6	B2
TD5	B7	B3
TD6	NA	NA
TE0	R8	R0(LSB)
TE1	R9(MSB)	R1
TE2	G8	G0(LSB)
TE3	G9(MSB)	G1
TE4	B8	B0(LSB)
TE5	B9(MSB)	B1
TE6	NA	NA

NA: Not Available

(\*)Since the display position is prescribed by the rise of DE(Display Enable)signal, please do not fix DE signal during operation at "High".

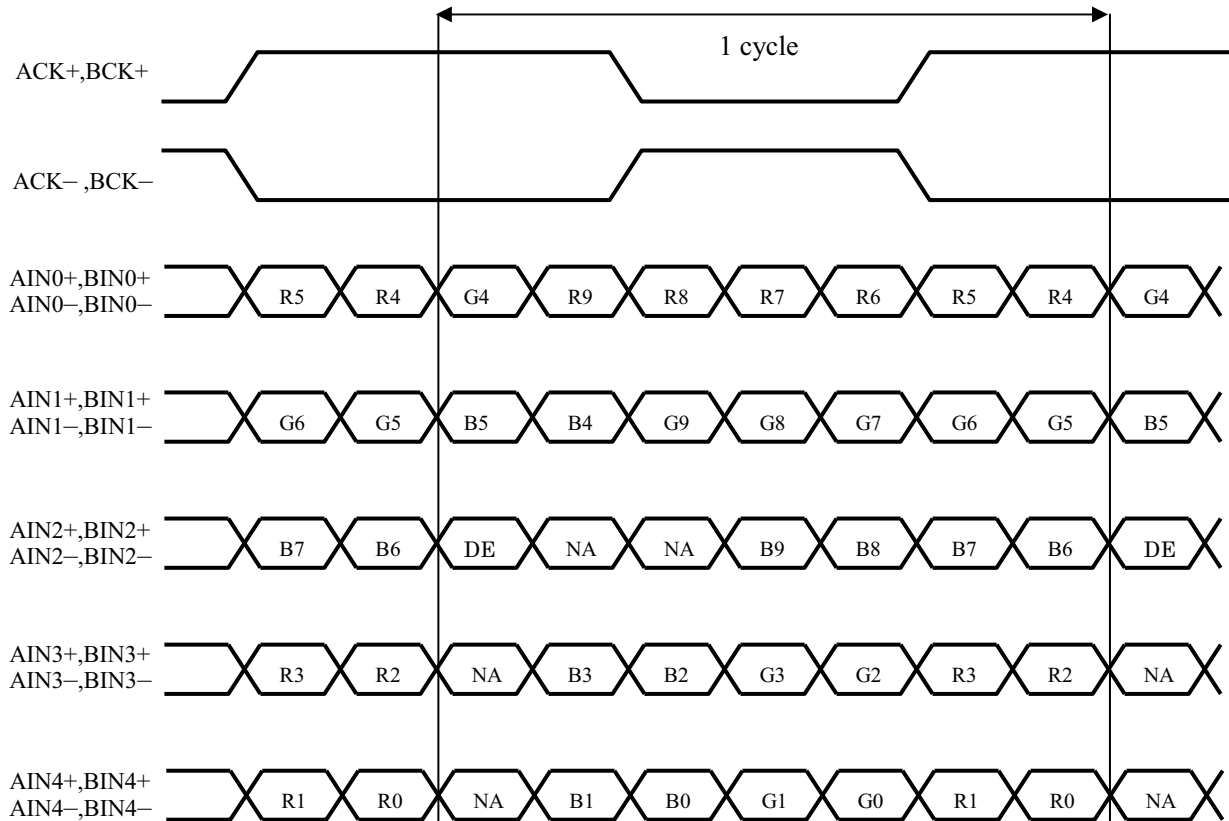
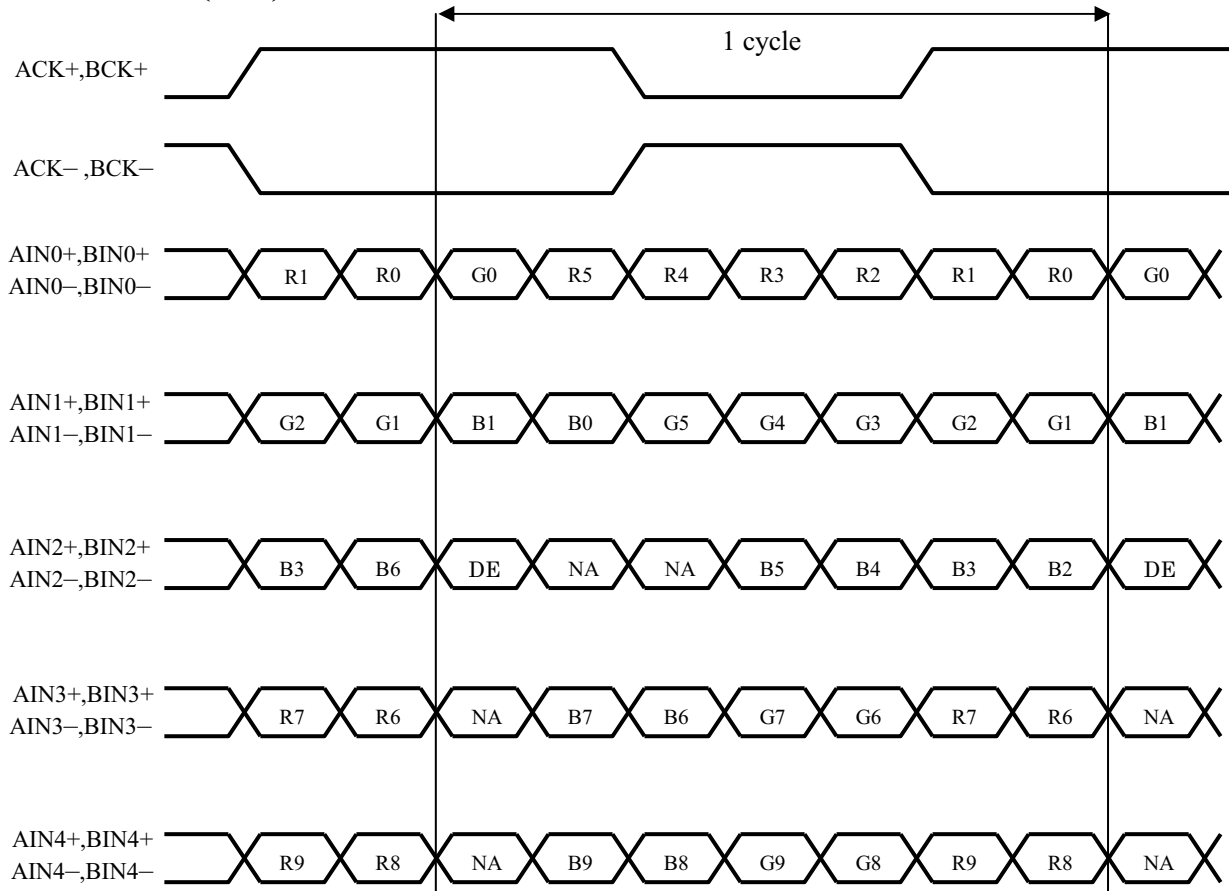
**SELLVDS= High (3.3V) or OPEN****SELLVDS= Low (GND)**

DE: Display Enable, NA: Not Available (Fixed Low)

[Note 3]The equivalent circuit figure of the terminal▲C

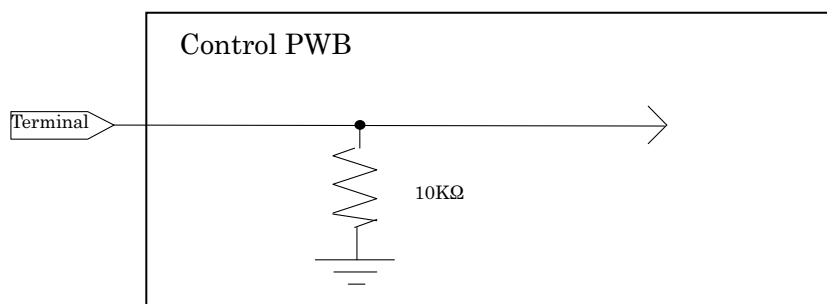

• Interface block diagram

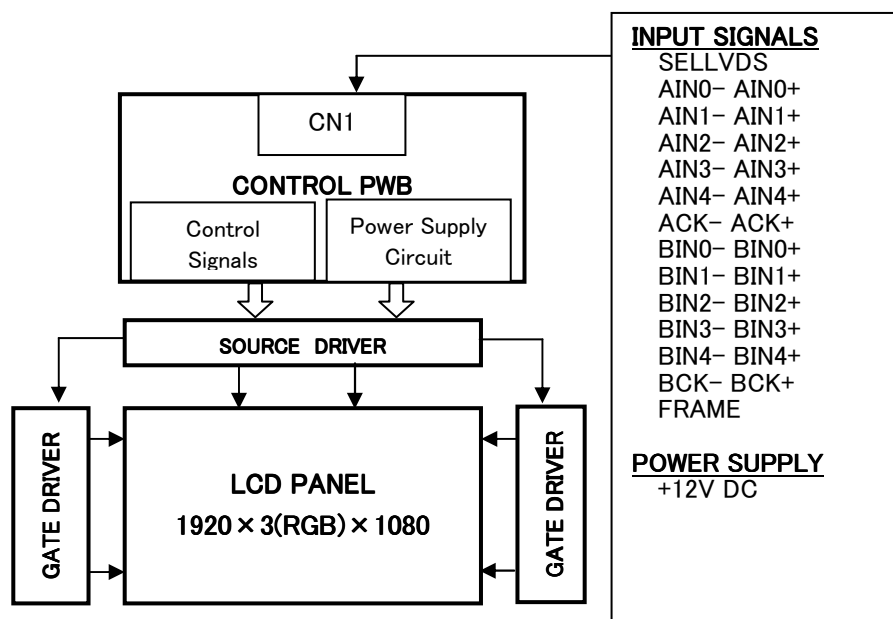

Fig.1 Interface block diagram

#### 4.2 Vcom Adjusting interface of Control PWB SHARP specifies

[LK0DZ1C0089(RUNTK4224TPZD)]

CN7 (Interface Vcom Adjusting) [note1]

Using Via Hole : 1.5mm Pitch (  $\phi$  0.7mm )

Mating connector : (housing)3P-SZN, (contact)SZN-002T-P0.7K (JST Co.,Ltd.)

Communication method : I2C

Pin No.	Symbol	Function	Remark
1	SDA	I2C DATA	Pull up 3.3V[Note2]
2	SCL	I2C CLK	Pull up 3.3V[Note2]
3	GND		

[Note1]Interface

[Note2] The equivalent circuit figure of the terminal



PinNo	1	2	3
Symbol	SDA	SCL	GND

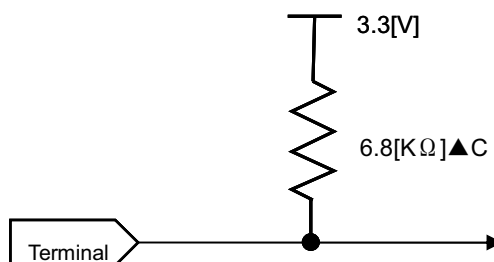

#### 4.3 Absolute Maximum Ratings

Parameter	Symbol	Condition	Ratings	Unit	Remark
Input voltage (for Control)	$V_i$	$T_a=25\text{ }^\circ\text{C}$	-0.3 ~ 3.6	V	[Note 1]
12V supply voltage (for Control)	VCC	$T_a=25\text{ }^\circ\text{C}$	0 ~ +14	V	
Storage temperature	Tstg	-	-25 ~ +60	$^\circ\text{C}$	[Note 2]
Operation temperature (Ambient)	Topa	-	0 ~ +50	$^\circ\text{C}$	

[Note 1] SELVDS FRAME ▲C

[Note 2] Humidity 95%RH Max.( $T_a \leq 40^\circ\text{C}$ )

Maximum wet-bulb temperature at  $39\text{ }^\circ\text{C}$  or less.( $T_a > 40^\circ\text{C}$ )

No condensation.



## 4.4 Electrical Characteristics of input signals

Ta=25 °C

Parameter	Symbol	Min.	Typ.	Max.	Unit	Remark	
+12V supply voltage	Supply voltage	V <sub>CC</sub>	11.4	12	12.6	V	[Note 1]
	Current dissipation	I <sub>CC</sub>	-	700	1400	mA	[Note 2]
	Inrush current	I <sub>RUSH</sub>	-	1500	-	mA	[Note 7]
Permissible input ripple voltage	V <sub>RP</sub>	-	-	100	mV <sub>P-P</sub>	V <sub>CC</sub> = +12.0V	
Differential input threshold voltage	High	V <sub>TH</sub>	-	-	100	mV	V <sub>CM</sub> = +1.2V [Note 6]
	Low	V <sub>TL</sub>	-100	-	-	mV	
Input Low voltage	V <sub>IL</sub>	0	-	1.0	V	[Note 3]	
Input High voltage	V <sub>IH</sub>	2.3	-	3.3	V		
Input leak current (Low)	I <sub>IL1</sub>	-	-	400	μA	V <sub>I</sub> = 0V [Note 4]	
	I <sub>IL2</sub>	-	-	40	μA	V <sub>I</sub> = 0V [Note 5]	
Input leak current (High)	I <sub>IH1</sub>	-	-	40	μA	V <sub>I</sub> = 3.3V [Note 4]	
	I <sub>IH2</sub>	-	-	400	μA	V <sub>I</sub> = 3.3V [Note 5]	
Terminal resistor	R <sub>T</sub>	-	100	-	Ω	Differential input	

[Note]V<sub>CM</sub>: Common mode voltage of LVDS driver.

[Note 1]

## Input voltage sequences

- 0 < t<sub>1</sub> ≤ 20ms
- 10 < t<sub>2</sub> ≤ 50ms
- 10 < t<sub>3</sub> ≤ 50ms
- 0 < t<sub>4</sub> ≤ 1s
- t<sub>5</sub> ≥ 300ms
- t<sub>6</sub> ≥ 0
- t<sub>7</sub> ≥ 300ms

## Dip conditions for supply voltage

- a) 6.5V ≤ V<sub>CC</sub> < 10.8V
- t<sub>d</sub> ≤ 10ms
- b) V<sub>CC</sub> < 6.5V

Dip conditions for supply voltage is based on input voltage sequence.

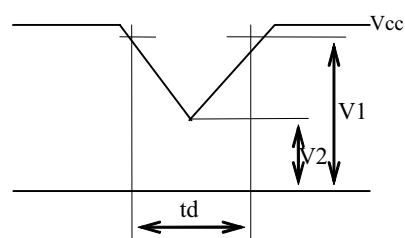
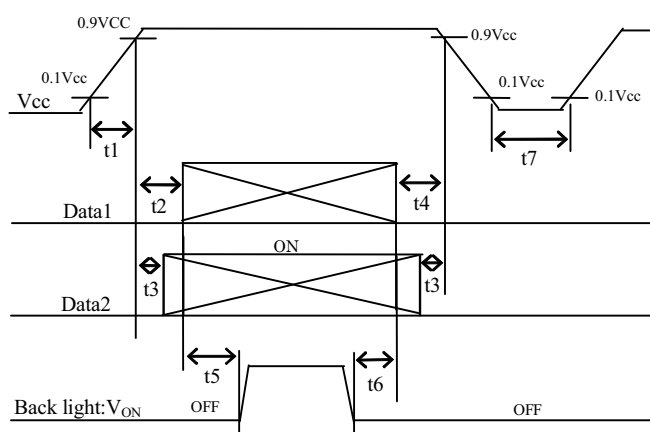
V<sub>1</sub>: 10.8V  
V<sub>2</sub>: 6.5V

- Data1: ACK±, AIN0±, AIN1±, AIN2±, AIN3±, AIN4±, BCK±, BIN0±, BIN1±, BIN2±, BIN3±, BIN4±  
\*V<sub>CM</sub> voltage pursues the sequence mentioned above
- Data2: SELLVDS, FRAME

[Note] About the relation between data input and back light lighting, please base on the above-mentioned input sequence. When back light is switched on before panel operation or after a panel operation stop, it may not display normally. But this phenomenon is not based on change of an incoming signal, and does not give damage to a liquid crystal display.

[Note 2] Typical current situation: 1023 gray-bar patterns. ( $V_{CC} = +12.0V$ )

The explanation of RGB gray scale is seen in section 8.

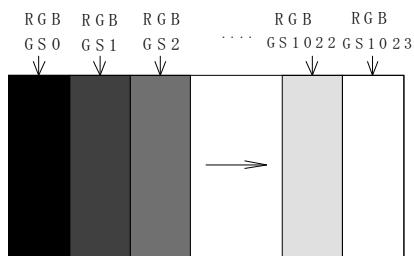

$V_{CC} = +12.0V$   
 $CK = 74.25MHz$   
 $T_h = 14.8\mu s$

[Note 3] SELLVDS, FRAME▲C

[Note 4] SELLVDS▲C

[Note 5] FRAME

[Note 6] ACK±, AIN0±, AIN1±, AIN2±, AIN3±, AIN4±, BCK±, BIN0±, BIN1±, BIN2±, BIN3±, BIN4±,

[Note 7]  $V_{CC}12V$  inrush current waveform (This figure is  $I_{RUSH} : t_1 = 500 \mu s$ )

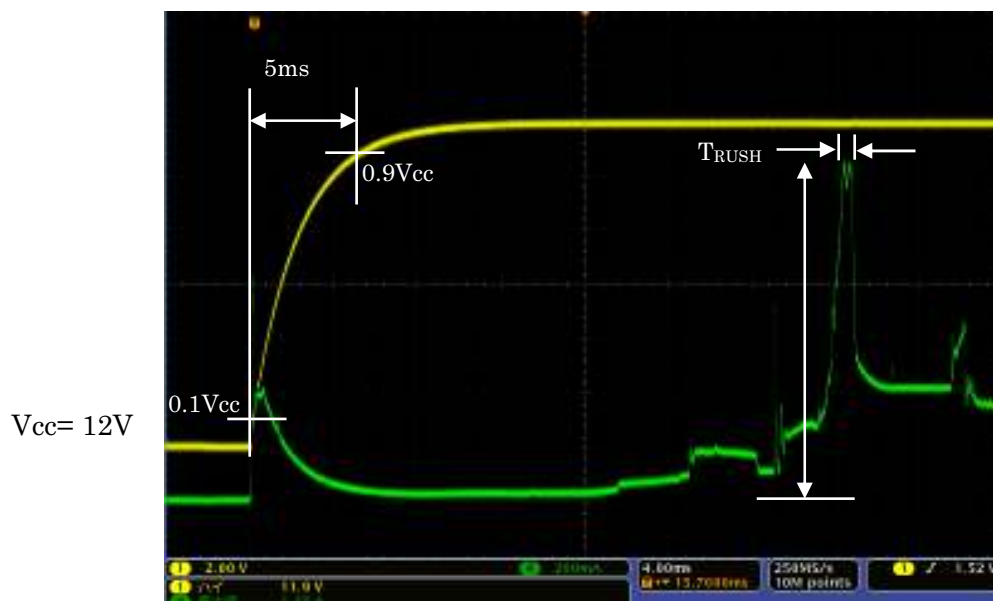

4ms/div

#### 4.5 Timing characteristics of input signals

Timing diagrams of input signal are shown in Fig.2.

Parameter		Symbol	Min.	Typ.	Max.	Unit	Remark
Clock	Frequency	1/Tc	67	74.25	76	MHz	
Data enable signal	Horizontal period	TH	1050	1100	1300	clock	
			14.2	14.8	16.1	$\mu$ s	
	Horizontal period (High)	THd	960	960	960	clock	
	Vertical period	TV	1109	1350	1125	line	
			47	50	60	Hz	
Vertical period (High)	TVd	1080	1080	1080	line		

[Note1] LVDS scew  $\pm 250$  p sec.

[Note2]-When vertical period is very long, flicker and etc. may occur.

-Please turn off the module after it shows the black screen.

-Please make sure that length of vertical period should become of an integral multiple of horizontal length of period. Otherwise, the screen may not display properly.

-As for your final setting of driving timing, we will conduct operation check test at our side, please inform your final setting.

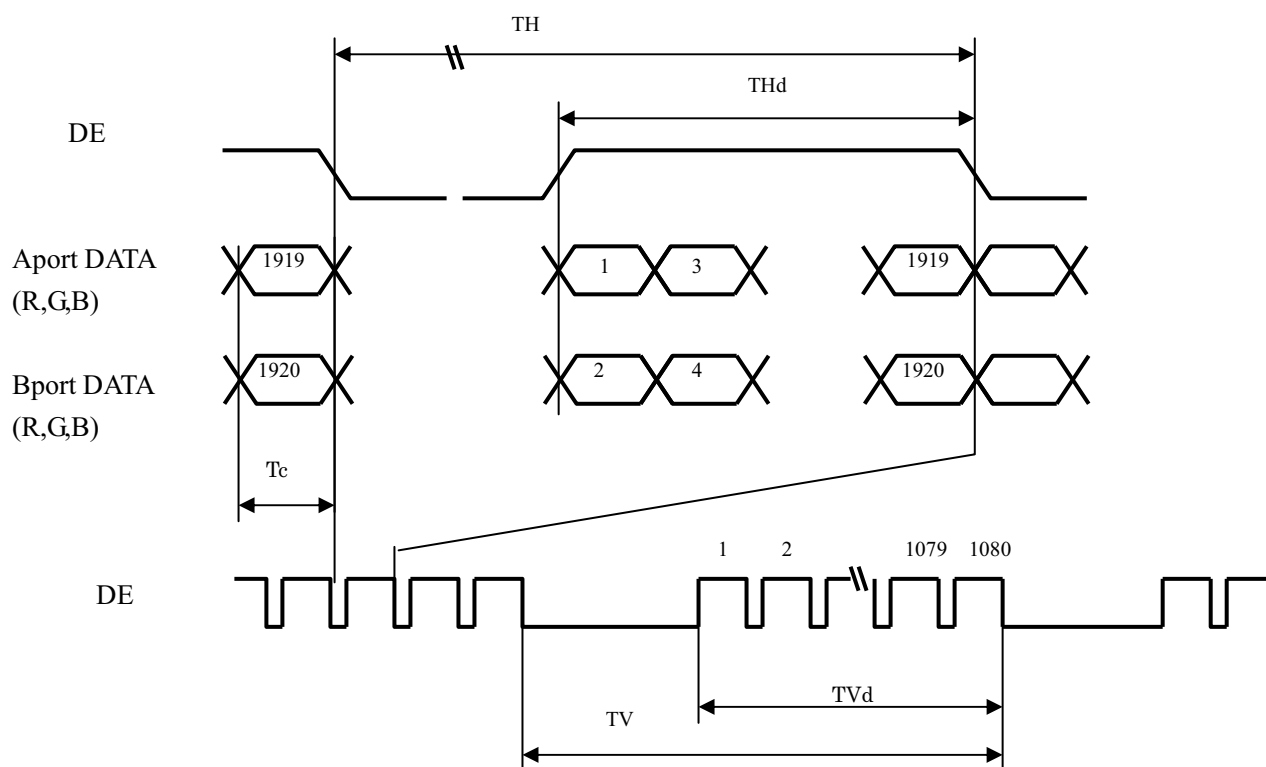
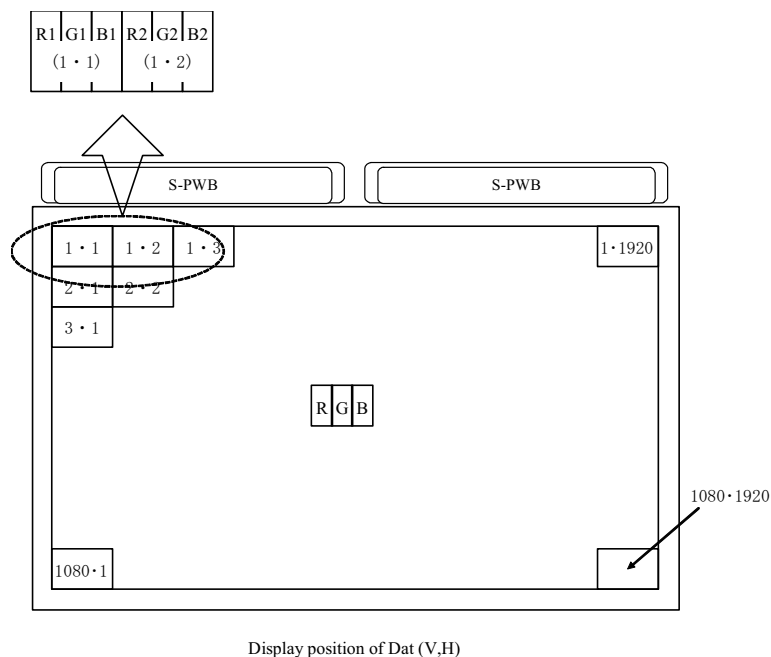
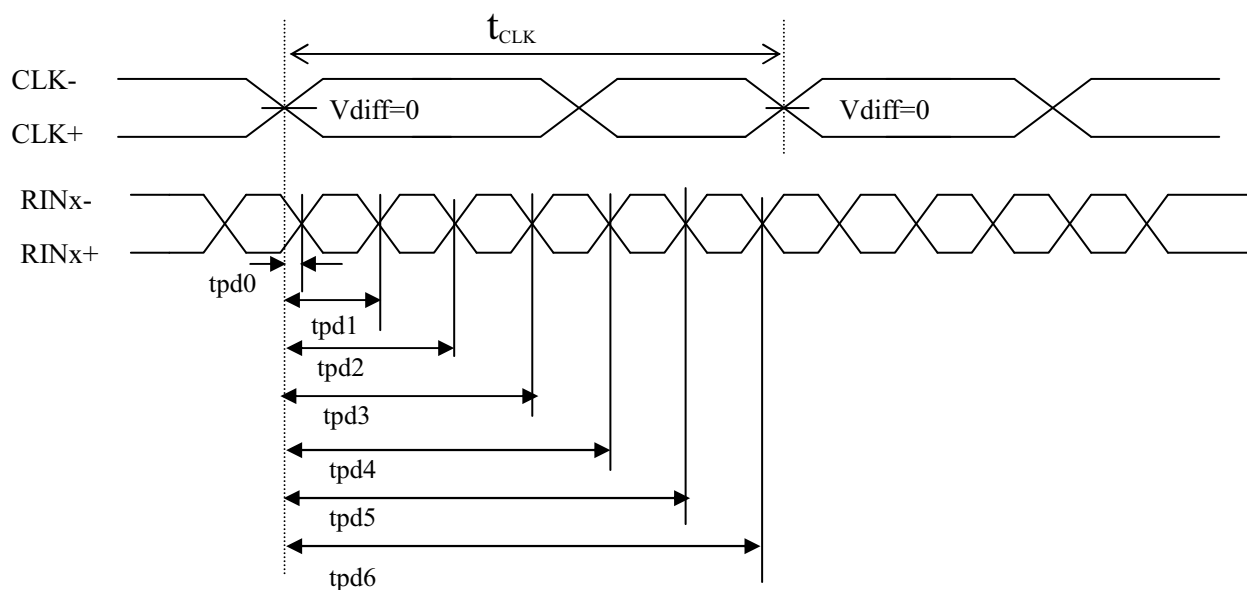

Fig.2 Timing characteristics of input signals

#### 4.6 Input data signal and display position on the screen



#### 4.7 LVDS signal characteristics



The item		Symbol	min.	typ.	max.	unit
Data position	Delay time, CLK rising edge to serial bit position 0	tpd0	-0.25	0	0.25	ns
	Delay time, CLK rising edge to serial bit position 1	tpd1	$1 * t_{CLK} / 7 - 0.25$	$1 * t_{CLK} / 7$	$1 * t_{CLK} / 7 + 0.25$	
	Delay time, CLK rising edge to serial bit position 2	tpd2	$2 * t_{CLK} / 7 - 0.25$	$2 * t_{CLK} / 7$	$2 * t_{CLK} / 7 + 0.25$	
	Delay time, CLK rising edge to serial bit position 3	tpd3	$3 * t_{CLK} / 7 - 0.25$	$3 * t_{CLK} / 7$	$3 * t_{CLK} / 7 + 0.25$	
	Delay time, CLK rising edge to serial bit position 4	tpd4	$4 * t_{CLK} / 7 - 0.25$	$4 * t_{CLK} / 7$	$4 * t_{CLK} / 7 + 0.25$	
	Delay time, CLK rising edge to serial bit position 5	tpd5	$5 * t_{CLK} / 7 - 0.25$	$5 * t_{CLK} / 7$	$5 * t_{CLK} / 7 + 0.25$	
	Delay time, CLK rising edge to serial bit position 6	tpd6	$6 * t_{CLK} / 7 - 0.25$	$6 * t_{CLK} / 7$	$6 * t_{CLK} / 7 + 0.25$	

## 5 Optical Specifications

### 5.1 Input Signal, Basic Display Colors and Gray Scale of Each Color

Colors & Gray scale	Data signal																															
	Gray Scale	R0	R1	R2	R3	R4	R5	R6	R7	R8	R9	G0	G1	G2	G3	G4	G5	G6	G7	G8	G9	B0	B1	B2	B3	B4	B5	B6	B7	B8	B9	
Basic Color	Black	-	0	0	0	0	0	0	0	0	0	0	0	0	0	0	0	0	0	0	0	0	0	0	0	0	0	0	0	0	0	0
	Blue	-	0	0	0	0	0	0	0	0	0	0	0	0	0	0	0	0	0	0	0	0	1	1	1	1	1	1	1	1	1	1
	Green	-	0	0	0	0	0	0	0	0	0	1	1	1	1	1	1	1	1	1	1	1	0	0	0	0	0	0	0	0	0	0
	Cyan	-	0	0	0	0	0	0	0	0	0	1	1	1	1	1	1	1	1	1	1	1	1	1	1	1	1	1	1	1	1	1
	Red	-	1	1	1	1	1	1	1	1	1	0	0	0	0	0	0	0	0	0	0	0	0	0	0	0	0	0	0	0	0	0
	Magenta	-	1	1	1	1	1	1	1	1	1	0	0	0	0	0	0	0	0	0	0	0	1	1	1	1	1	1	1	1	1	1
	Yellow	-	1	1	1	1	1	1	1	1	1	1	1	1	1	1	1	1	1	1	1	1	0	0	0	0	0	0	0	0	0	0
	White	-	1	1	1	1	1	1	1	1	1	1	1	1	1	1	1	1	1	1	1	1	1	1	1	1	1	1	1	1	1	1
Gray Scale of Red	Black	GS0	0	0	0	0	0	0	0	0	0	0	0	0	0	0	0	0	0	0	0	0	0	0	0	0	0	0	0	0	0	0
	↑	GS1	1	0	0	0	0	0	0	0	0	0	0	0	0	0	0	0	0	0	0	0	0	0	0	0	0	0	0	0	0	0
	Darker	GS2	0	1	0	0	0	0	0	0	0	0	0	0	0	0	0	0	0	0	0	0	0	0	0	0	0	0	0	0	0	0
	↑	↓																														
	↓	↓																														
	Brighter	GS1021	1	0	1	1	1	1	1	1	1	0	0	0	0	0	0	0	0	0	0	0	0	0	0	0	0	0	0	0	0	0
	↓	GS1022	0	1	1	1	1	1	1	1	1	0	0	0	0	0	0	0	0	0	0	0	0	0	0	0	0	0	0	0	0	0
	Red	GS1023	1	1	1	1	1	1	1	1	1	0	0	0	0	0	0	0	0	0	0	0	0	0	0	0	0	0	0	0	0	0
Gray Scale of Green	Black	GS0	0	0	0	0	0	0	0	0	0	0	0	0	0	0	0	0	0	0	0	0	0	0	0	0	0	0	0	0	0	0
	↑	GS1	0	0	0	0	0	0	0	0	0	1	0	0	0	0	0	0	0	0	0	0	0	0	0	0	0	0	0	0	0	0
	Darker	GS2	0	0	0	0	0	0	0	0	0	0	1	0	0	0	0	0	0	0	0	0	0	0	0	0	0	0	0	0	0	0
	↑	↓																														
	↓	↓																														
	Brighter	GS1021	0	0	0	0	0	0	0	0	0	1	0	1	1	1	1	1	1	1	1	1	0	0	0	0	0	0	0	0	0	0
	↓	GS1022	0	0	0	0	0	0	0	0	0	0	1	1	1	1	1	1	1	1	1	1	0	0	0	0	0	0	0	0	0	0
	Green	GS1023	0	0	0	0	0	0	0	0	0	1	1	1	1	1	1	1	1	1	1	1	0	0	0	0	0	0	0	0	0	0
Gray Scale of Blue	Black	GS0	0	0	0	0	0	0	0	0	0	0	0	0	0	0	0	0	0	0	0	0	0	0	0	0	0	0	0	0	0	0
	↑	GS1	0	0	0	0	0	0	0	0	0	0	0	0	0	0	0	0	0	0	0	0	1	0	0	0	0	0	0	0	0	0
	Darker	GS2	0	0	0	0	0	0	0	0	0	0	0	0	0	0	0	0	0	0	0	0	0	1	0	0	0	0	0	0	0	0
	↓	↓																														
	↓	↓																														
	Brighter	GS1021	0	0	0	0	0	0	0	0	0	0	0	0	0	0	0	0	0	0	0	0	1	0	1	1	1	1	1	1	1	1
	↓	GS1022	0	0	0	0	0	0	0	0	0	0	0	0	0	0	0	0	0	0	0	0	0	1	1	1	1	1	1	1	1	1
	Blue	GS1023	0	0	0	0	0	0	0	0	0	0	0	0	0	0	0	0	0	0	0	0	1	1	1	1	1	1	1	1	1	1

0: Low level voltage, 1: High level voltage.

Each basic color can be displayed in 1021 gray scales from 10 bits data signals. According to the combination of total 30 bits data signals, one billion-color display can be achieved on the screen.

## 6 Optical Specifications

### 6.1 Optical characteristics ▲C

Ta=25°C, Vcc=12.0V, Vinv=24V, Timing:60Hz(typ. value)

Parameter		Symbol	Condition	Min.	Typ.	Max.	Unit	Remark	
Viewing angle range	Horizontal	$\theta_{21}$ $\theta_{22}$	$CR \geq 10$	70	88	-	Deg.	[Note1,4]	
	Vertical	$\theta_{11}$ $\theta_{12}$		70	88	-	Deg.		
Contrast ratio		CRn	$\theta = 0 \text{ deg.}$	2000	2500	-	-	[Note2,4]	
Response time		$\tau_{DRV}$			6			ms	[Note3,4,5]
Luminance	White	x		Typ.-0.03	0.278	Typ.+0.03	-		[Note4]
		y		Typ.-0.03	0.285	Typ.+0.03	-		
	Red	x		Typ.-0.03	0.644	Typ.+0.03	-		
		y		Typ.-0.03	0.344	Typ.+0.03	-		
	Green	x		Typ.-0.03	0.284	Typ.+0.03	-		
		y		Typ.-0.03	0.607	Typ.+0.03	-		
	Blue	x		Typ.-0.03	0.147	Typ.+0.03	-		
		y		Typ.-0.03	0.069	Typ.+0.03	-		
Luminance	White	$Y_L$	-	500	-	cd/m <sup>2</sup>			
Luminance uniformity	White	$\delta w$	-	-	1.25		[Note 6]		

\*Optical characteristics are based on SHARP module LK400D3LA14

-The measurement shall be executed 60 minutes after lighting at rating.

[Note]The optical characteristics are measured using the following equipment.

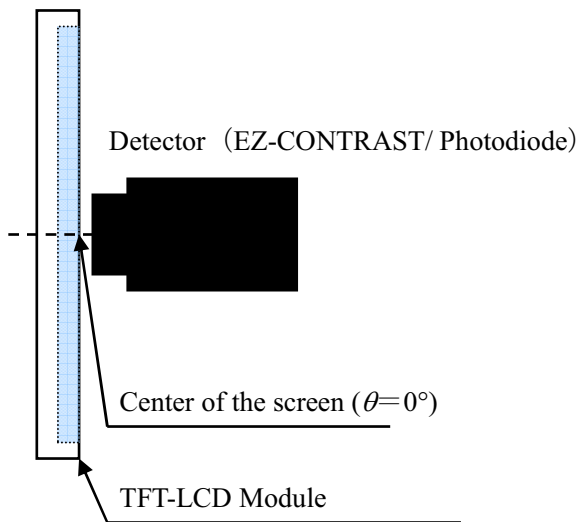

Fig.4-1 Measurement of viewing angle range and Response time.

Viewing angle range: EZ-CONTRAST

Response time: Photodiode

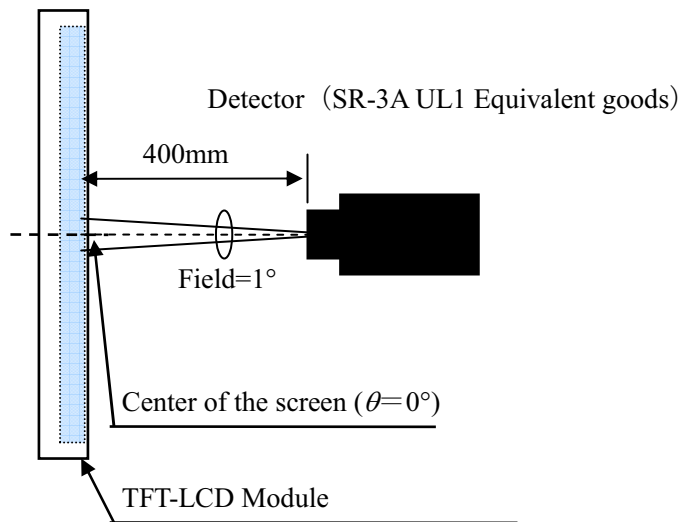
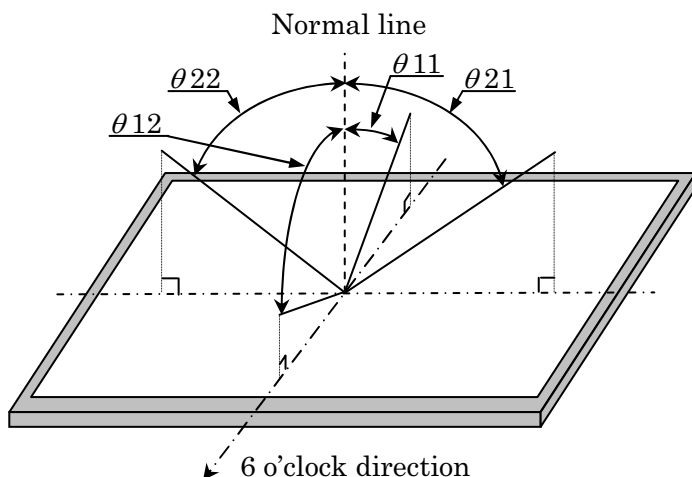

Fig.4-2 Measurement of Contrast, Luminance, Chromaticity.

[Note 1]Definitions of viewing angle range :



[Note 2]Definition of contrast ratio :

The contrast ratio is defined as the following.

$$\text{Contrast Ratio} = \frac{\text{Luminance (brightness) with all pixels white}}{\text{Luminance (brightness) with all pixels black}}$$

[Note 3]Definition of response time ▲C

The response time ( $\tau$ ) is defined as the following figure and shall be measured by switching the input signal for “any level of gray (0%, 25%, 50%, 75% and 100%)” and “any level of gray (0%, 25%, 50%, 75% and 100%)”.

	0%	25%	50%	75%	100%
0%		tr:0%-25%	tr:0%-50%	tr:0%-75%	tr:0%-100%
25%	td: 25%-0%		tr: 25%-50%	tr25%-75%	tr: 25%-100%
50%	td: 50%-0%	td: 50%-25%		tr: 50%-75%	tr: 50%-100%
75%	td: 75%-0%	td: 75%-25%	td: 75%-50%		tr: 75%-100%
100%	td: 100%-0%	td: 100%-25%	td: 100%-50%	td:100%-75%	

t\*:x-y...response time from level of gray(x) to level of gray(y)

$$\tau = \Sigma(t*:x-y)/20$$

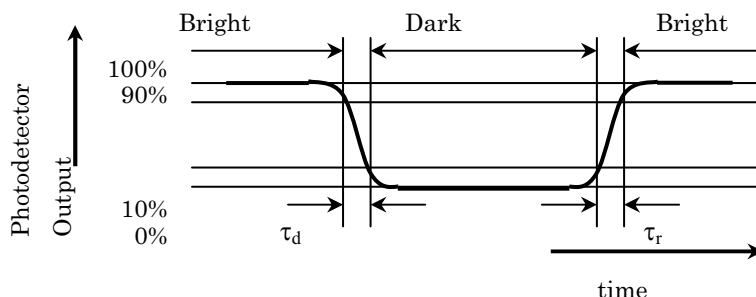

[Note 4]This shall be measured at center of the screen.

[Note 5] This value is valid when O/S driving is used at typical input time value.

[Note 6]

White uniformity is defined as the following with five measurements. (A~E)

$$\delta_w = \frac{\text{Maximum luminance of five points (brightness)}}{\text{Minimum luminance of five points (brightness)}}$$

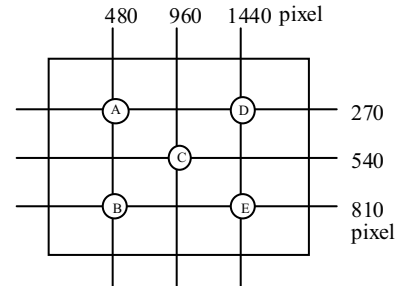

## 7 Shipping and Packing

### 7.1 Packing form

For JAPAN and D.ID production (▲B ▲C)

- a) Piling number of cartons : 14 cell box / 1 palette
- b) Packing quantity in one cell box : 10pcs. (type A and type B)  
: 15pcs. (type C)
- c) Carton size : 1360 (W)×1120 (D)×1063 (H) (type A)  
: 1390 (W)×1150 (D)×1059(H) (type C)  
: 1390 (W)×1150 (D)×984 (H) (type B)
- d) Total mass of one carton filled with full cell : 358.4 kg(Max) (type A and type B)  
: 409.5 kg(Max) (type C)

### 7.2 Label (▲A, ▲B, ▲C)

#### a) Cell Label

This label is stuck on the protection film of front polarizer.

(Please trace the Cell lot number after the film is peeled off.)

[LK400D3HA14,HA14E] JAPAN PRODUCTION

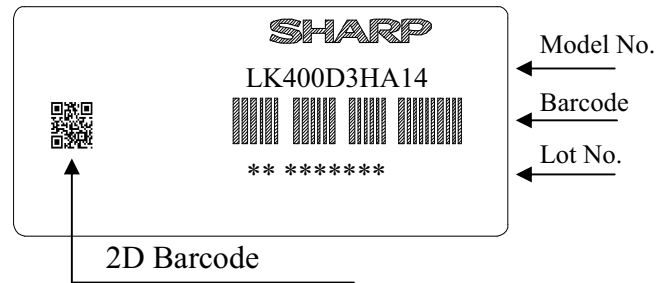
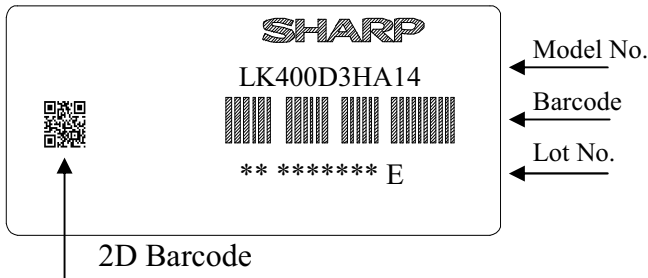

[LK400D3HA14D] D.ID PRODUCTION

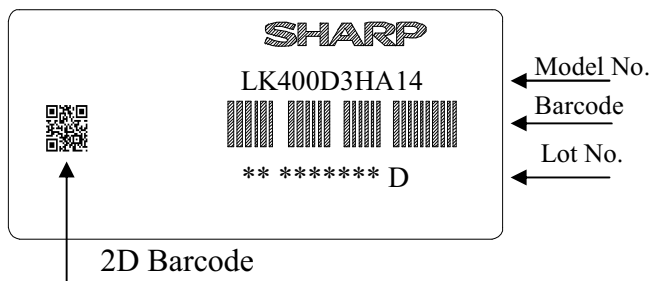



How to express Lot No.

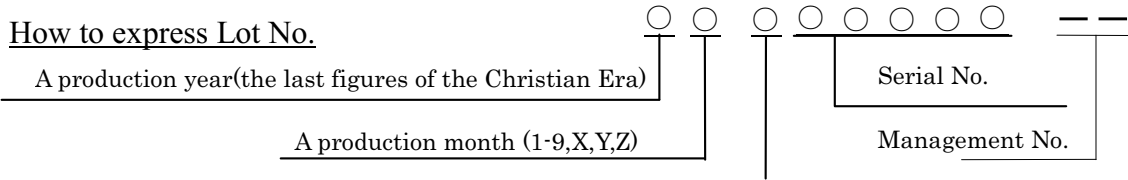

Identification Code

K: Kameyama Plant.	P: SMPL
L: Kameyama Tec. Kameyama Fab.	G: SMM
J: Kameyama Tec. Yaita Fab.	X: SEMEX
S: SHM	A or B: JABIL
N: NSEC	F :D.ID

b) Packing Label

b)-1 Open Cell box

Management No. : LK400D3HA14, LK400D3HA14D, LK400D3LA14E

• Packing form type A and B

• Packing form type C

社内品番 : \* \* \* \* \* (①)

Bar code

Lot NO. • (1 T) \* \* \* \* . \* . \* \* (②)

Bar code                      10   p c s (③)

Quantity :                      (Q)

Bar code

ユーザ品番

Bar code

シャープ物流用ラベルです。

社内品番 : \* \* \* \* \* (①)

Bar code

Lot NO. • (1 T) \* \* \* \* . \* . \* \* (②)

Bar code                      15   p c s (③)

Quantity :                      (Q)

Bar code

ユーザ品番

Bar code

シャープ物流用ラベルです。

① Management No.    ②Lot No. (Date)    ③Quantity

b)-2 Carton

Management No. : LK400D3HA14, LK400D3HA14D, LK400D3LA14E

• Packing form type A and B

• Packing form type C

社内品番 : \* \* \* \* \* (①)

Bar code

Lot NO. • (1 T) \* \* \* \* . \* . \* \* (②)

Bar code                      140   p c s (③)

Quantity :                      (Q)

Bar code

ユーザ品番

Bar code

シャープ物流用ラベルです。

社内品番 : \* \* \* \* \* (①)

Bar code

Lot NO. • (1 T) \* \* \* \* . \* . \* \* (②)

Bar code                      210   p c s (③)

Quantity :                      (Q)

Bar code

ユーザ品番

Bar code

シャープ物流用ラベルです。

① Management No.    ②Lot No. (Date)    ③Quantity

**8 Carton storage condition.**

Temperature	0°C to 40°C
Humidity	95%RH or less
Reference condition	: 20°C to 35°C, 85%RH or less. (summer) : 5°C to 15°C, 85%RH or less. (winter) · the total storage time (40°C, 95%RH) : 240H or less
Sunlight	Be sure to shelter a product from the direct sunlight.
Atmosphere	Harmful gas, such as acid and alkali which bites electronic components and/or wires must not be detected.
Notes	Be sure to put cartons on palette or base, don't put it on floor, and store them with removing from wall Please take care of ventilation in storehouse and around cartons, and control changing temperature is within limits of natural environment
Storage life	1 year

**9 Reliability**

Reliability test item

Open Cell

No.	Test item	Condition
1	High temperature storage test	Ta=60°C 240h
2	Low temperature storage test	Ta=-25°C 240h
3	High temperature and high humidity operation test	Ta=40°C ; 95%RH 240h (No condensation)
4	High temperature operation test	Ta=50°C 240h
5	Low temperature operation test	Ta=0°C 240h

Above tests are executed under the CCFL module conditions

**10 Handling Precautions of the Open Cell ▲C**

- Be sure to turn off the power supply when inserting or disconnecting the cable.
- Be sure to design the module and cabinet so that the open cell can be installed without any extra stress such as warp or twist.
- Since the polarizer is easily damaged, pay attention not to scratch it.
- Since long contact with water may cause discoloration or spots, wipe off water drop immediately.
- When the panel surface is soiled, wipe it with absorbent cotton or other soft cloth.
- Since the panel is made of glass, it may break or crack if dropped or bumped on hard surface.  
Handle with care.
- Since an open cell consists of a TFT cell and electronic circuits with CMOS-ICs, which are very weak to electrostatic discharge, persons who are handling an open cell should be grounded through adequate methods such as an anti-static wrist band. Connector pins should not be touched directly with bare hands.

·Reference : Process control standard of sharp

	item	Management standard value and performance standard
1	Anti-static mat(shelf)	1 to 50 [Mega ohm]
2	Anti-static mat(floor,desk)	1 to 100 [Mega ohm]
3	Ionizer	Attenuate from ±1000V to ±100V within two seconds.
4	Anti-static wrist band	0.8 to 10 [Mega ohm]
5	Anti-static wrist band entry and ground resistance	Below 1000 [ohm]
6	Temperature	22 to 26 [°C]
7	Humidity	60 to 70 [%]

- h) The open cell has some PWBs, take care to keep them from any stress or pressure when handling or installing the open cell; otherwise some of electronic parts on the PWBs may be damaged.
- i) When handling open cell modules and assembling them into cabinets, please be noted that long-term storage in the environment of oxidization or deoxidization gas and the use of such materials as reagent, solvent, adhesive, resin, etc. which generate these gasses, may cause corrosion and discoloration of the open cells.
- j) Observe all other precautionary requirements in handling components.
- k) Applying too much force and stress to PWB and driver (COF) may cause a malfunction electrically and mechanically.
- l) The open cell has high frequency circuits. Sufficient suppression to EMI should be done by system manufacturers.

m) When you peel the protection film for a polarizer.

- The protection film should be peeled as Fig.3

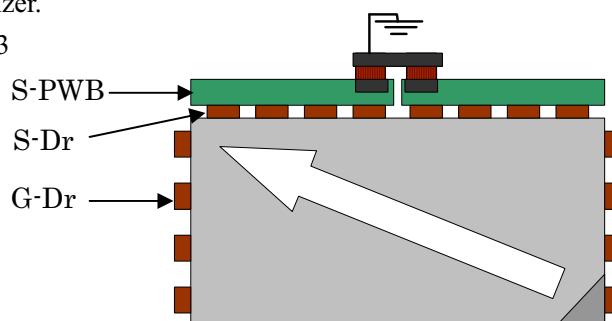
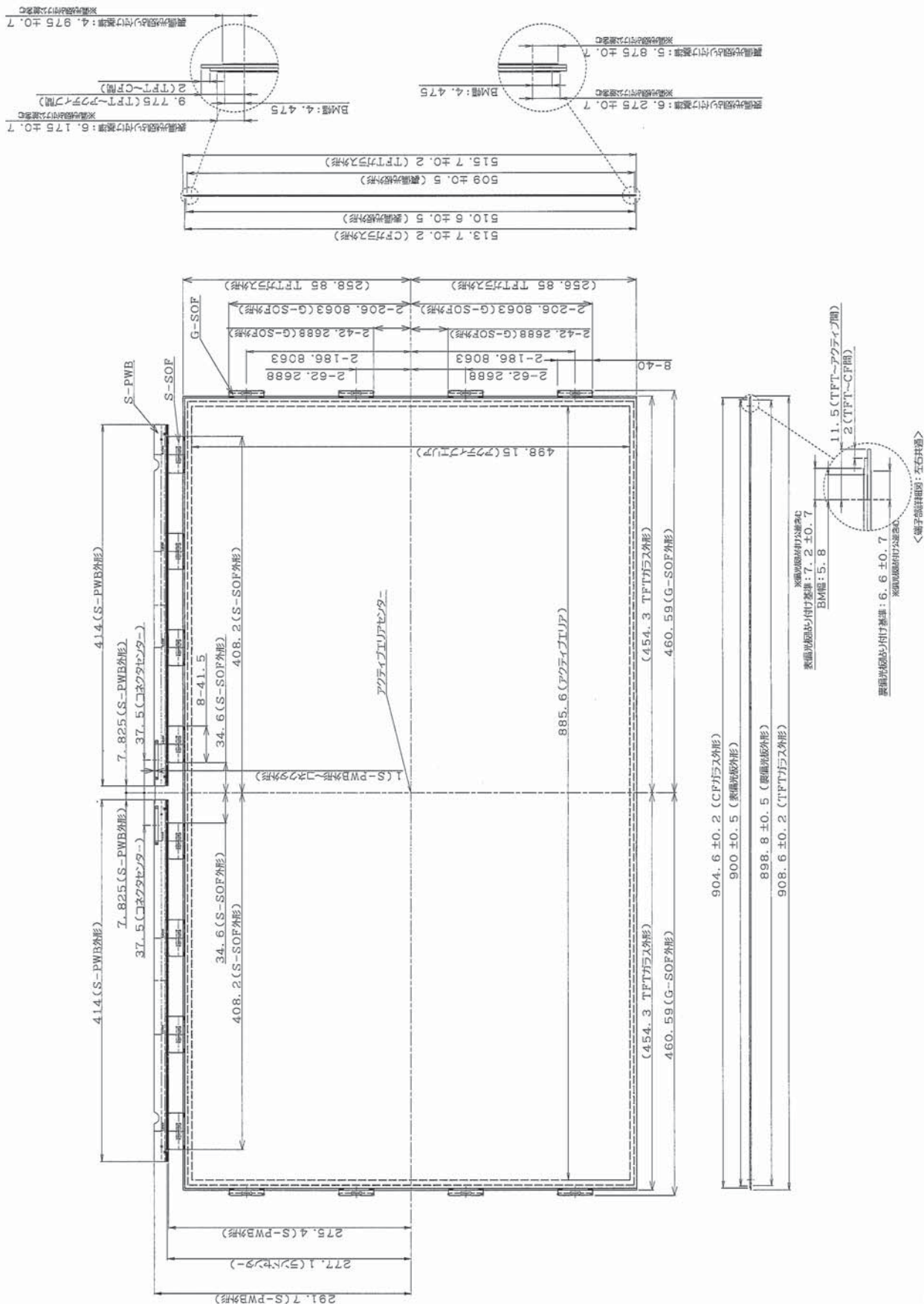

Fig.3 Direction peeled off

- Slowly((Recommendation : more than 5[sec]) & constant speed
  - Persons who are electrically grounded with adequate methods such as an anti-static wrist band.
  - Ionized air should be blown over the during peeling action.
  - Ground S-PWB connectors while peeling of a protection film.
  - The protection film must not touch DRIVER and S-PWB.
  - Please remove with isopropyl-alcohol if adhesive may remain on a polarizer after a protection film is peeled off.
- n) Electrical components which may not affect electrical performance are subjective to change without notice because of their availability.

## 11 Others

- 1) Please be careful since image retention may occur when a fixed pattern is displayed for a long time.
- 2) The chemical compound, which causes the destruction of ozone layer, is not being used.
- 3) This Open Cell module is corresponded to RoHS.
- 4) When any question or issue occurs, it shall be solved by mutual discussion.



Outline dimension of LK400D3HA14

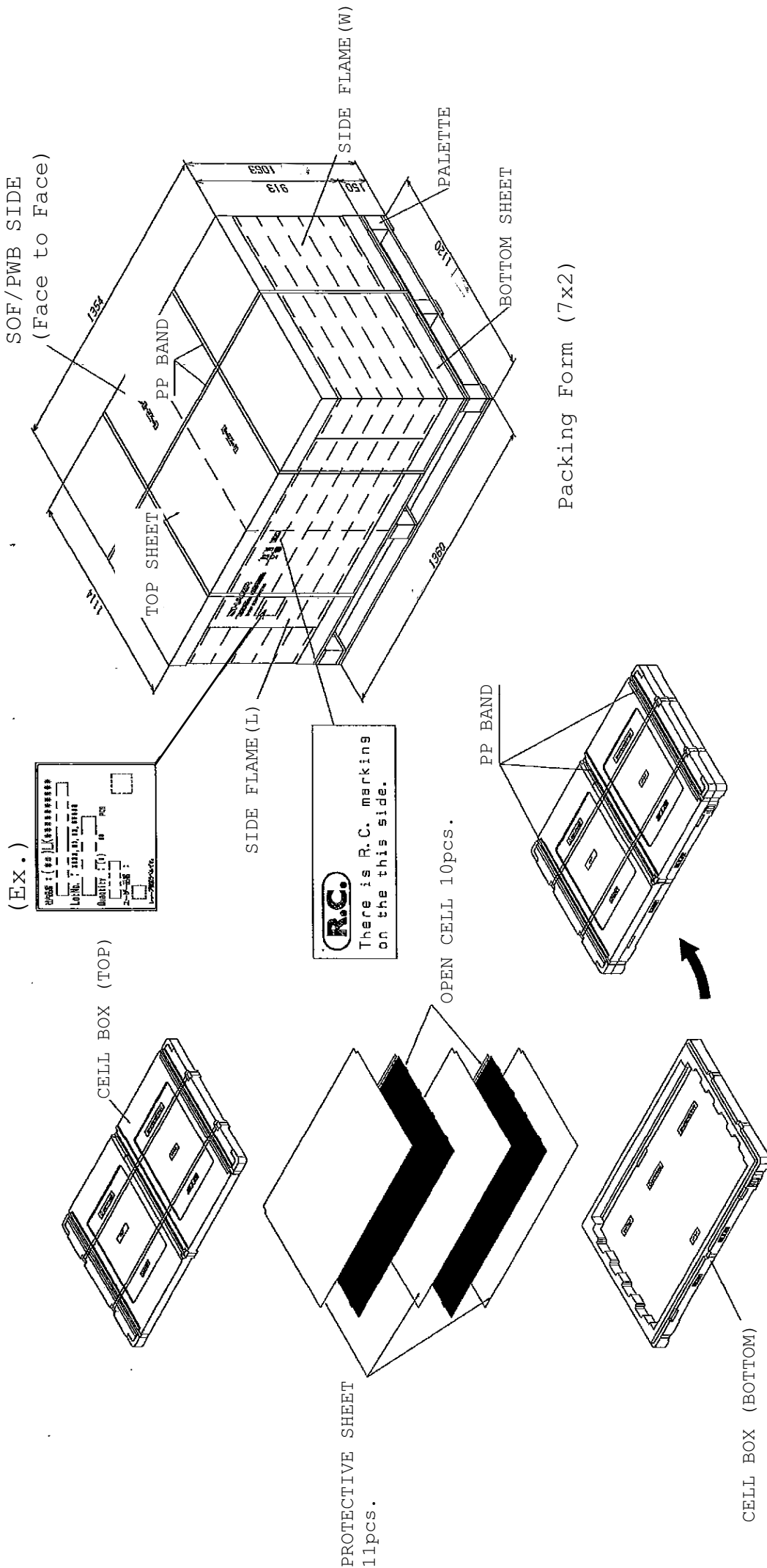

# 40 INCH OPEN CELL Packing Form (Type A)

PARTS NAME	MATERIAL
1 CELL BOX (BOTTOM)	EPS
2 CELL BOX (TOP)	EPS
3 TOP/BOTTOM SHEET	CARDBOARD
4 SIDE FRAME (L/	CARDBOARD
5 PALETTE	PLYWOOD
6 PROTECTIVE SHEET	PE (t=1.0)
7 CORNER REINFORCEMENT	LDPE

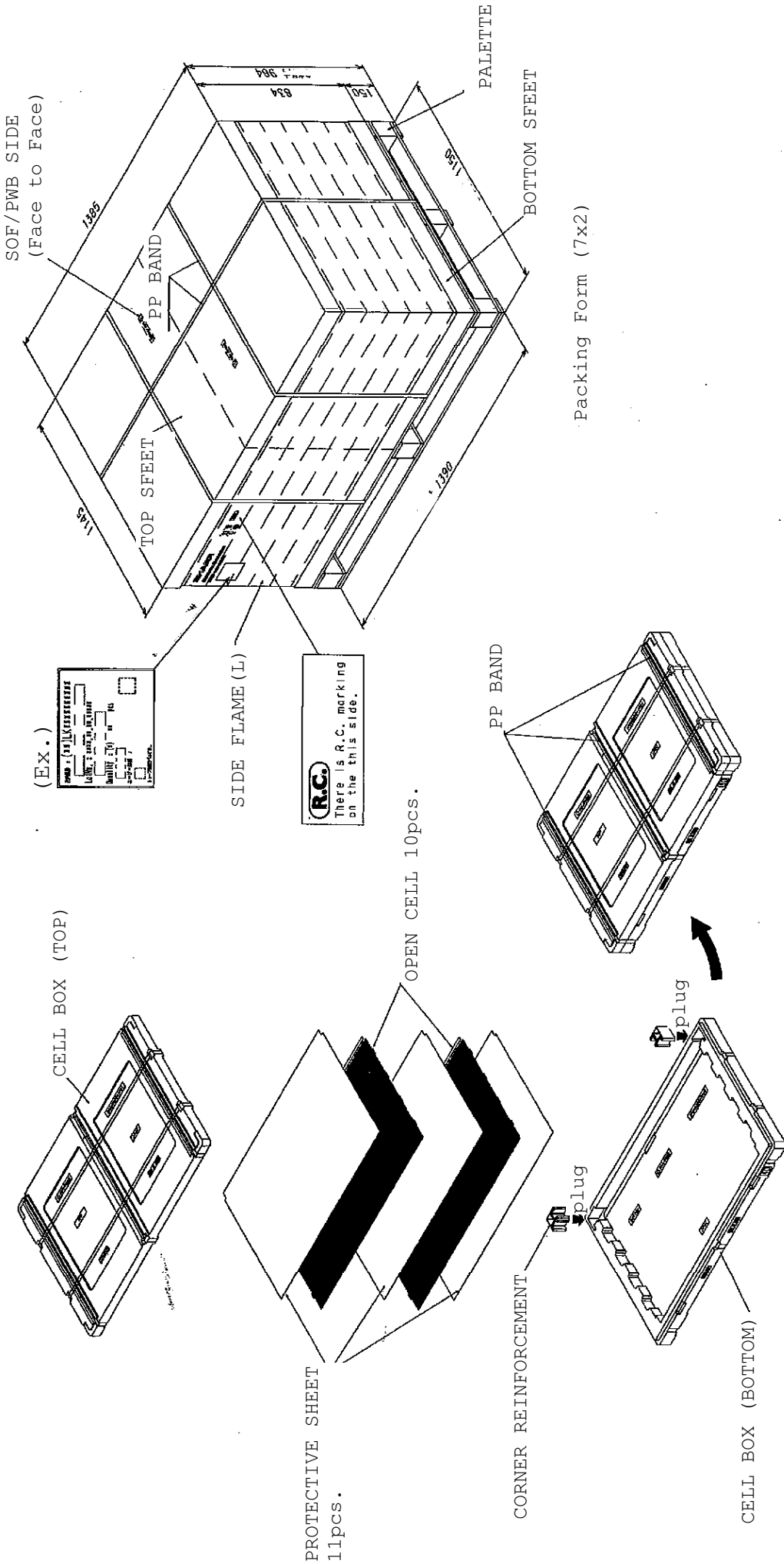

Packing Form (7x2)

# 40 INCH OPEN CELL Packing Form (Type B)

PARTS NAME	MATERIAL
1 CELL BOX (BOTTOM)	EPS
2 CELL BOX (TOP)	EPS
3 TOP/BOTTOM SHEET	CARDBOARD
4 SIDE FRAME	CARDBOARD
5 PALETTE	PLYWOOD
6 PROTECTIVE SHEET	PE (t=1.0)
7 CORNER REINFORCEMENT	LDPE

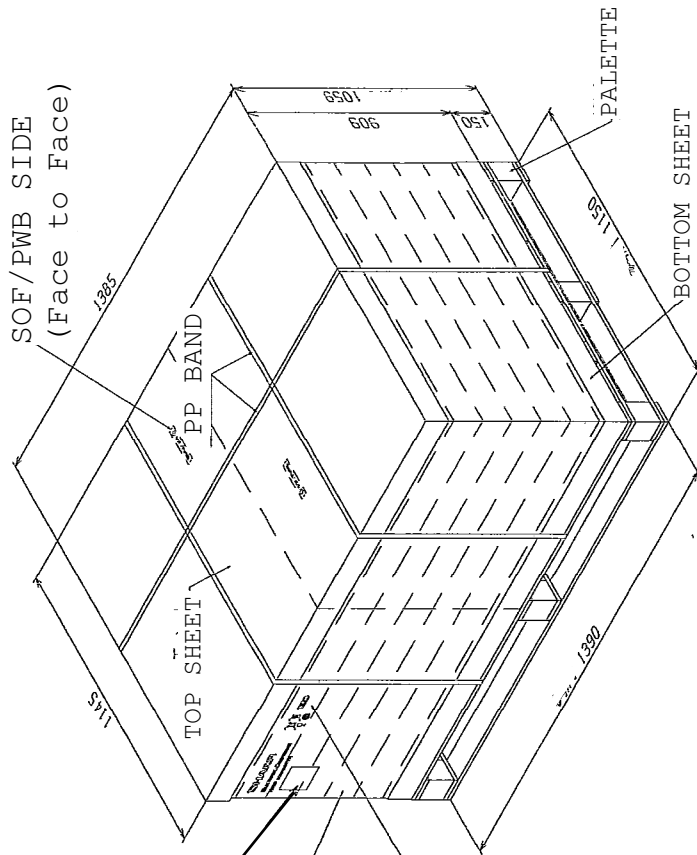

Packing Form (7x2)

# 40 INCH OPEN CELL Packing Form (Type C)

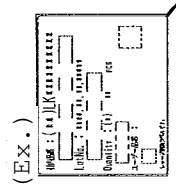

SIDE FLAME (L)

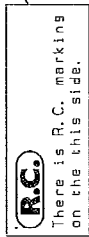

OPEN CELL 15pcs.

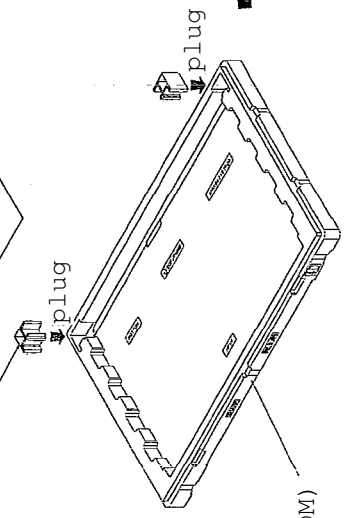
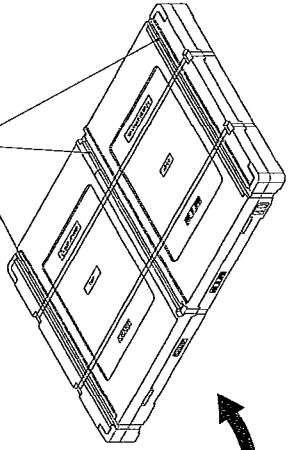
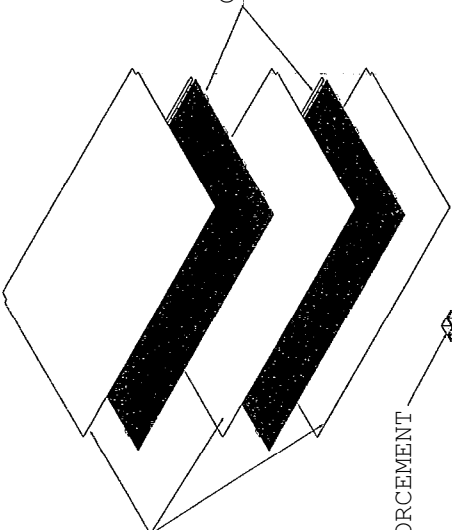
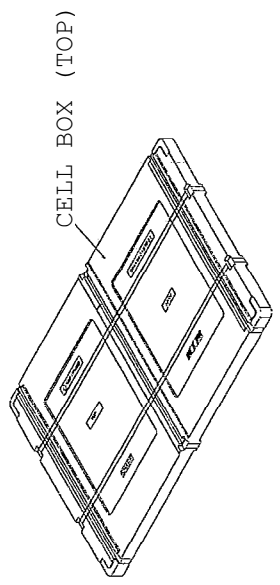

PARTS NAME	MATERIAL
1 CELL BOX (BOTTOM)	EPS
2 CELL BOX (TOP)	EPS
3 TOP/BOTTOM SHEET	CARDBOARD
4 SIDE FRAME	CARDBOARD
5 PALETTE	PLYWOOD
6 PROTECTIVE SHEET	PE (t=1.0)
7 CORNER REINFORCEMENT	LDPE