

PREPARED BY: _____	DATE _____	 LIQUID CRYSTAL DISPLAY GROUP SHARP CORPORATION SPECIFICATION	SPEC No. LD-K22223A
APPROVED BY: _____	DATE _____		FILE No. _____
			ISSUE: April, 12, 2010
			PAGE : 20 pages
			LIQUID CRYSTAL DISPLAY DIVISION I LIQUID CRYSTAL DISPLAY GROUP

DEVICE SPECIFICATION FOR

TFT-LCD OpenCell

 MODEL No. LK400D3HA3K

CUSTOMER'S APPROVAL

DATE _____

BY _____

PRESENTED

BY T. Shimada

T. Shimada
 General Manager
 LIQUID CRYSTAL DISPLAY DIVISION I
 LIQUID CRYSTAL DISPLAY GROUP
 SHARP CORPORATION

1 Application

This specification applies to the color 40.0" TFT-LCD Open Cell LK400D3HA3K

* This specification is proprietary products of SHARP CORPORATION ("SHARP") and include materials protected under copyright of SHARP. Do not reproduce or cause any third party to reproduce them in any form or by any means, electronic or mechanical, for any purpose, in whole or in part, without the express written permission of SHARP.

* In case of using the device for applications such as control and safety equipment for transportation (aircraft, trains, automobiles, etc.), rescue and security equipment and various safety related equipment which require higher reliability and safety, take into consideration that appropriate measures such as fail-safe functions and redundant system design should be taken.

* Do not use the device for equipment that requires an extreme level of reliability, such as aerospace applications, telecommunication equipment (trunk lines), nuclear power control equipment and medical or other equipment for life support.

* SHARP assumes no responsibility for any damage resulting from the use of the device that does not comply with the instructions and the precautions specified in these technical literature.

* Contact and consult with a SHARP sales representative for any questions about this device.

2 Overview

This Open Cell is a color active matrix LCD Open-Cell incorporating amorphous silicon TFT (Thin Film Transistor). It is composed of a color TFT-LCD panel, driver ICs and Source PWB. The following content can be achieved in using LK0DZ1C0115 (C-PWB) and LK0DZ1C0114 (FPC) that SHARP specifies. Graphics and texts can be displayed on a $1920 \times \text{RGB} \times 1080$ dots panel with one billion colors by using 10bit+ LVDS (Low Voltage Differential Signaling) to interface, +12V of DC supply voltages.

And in order to improve the response time of LCD, This module applies the Over Shoot driving (O/S driving) technology for the control circuit. In the O/S driving technology, signals are being applied to the Liquid Crystal according to a pre-fixed process as an image signal of the present frame when a difference is found between image signal of the previous frame and that of the current frame after comparing them.

With combination of these technologies, motion blur can be reduced and clearer display performance can be realized.

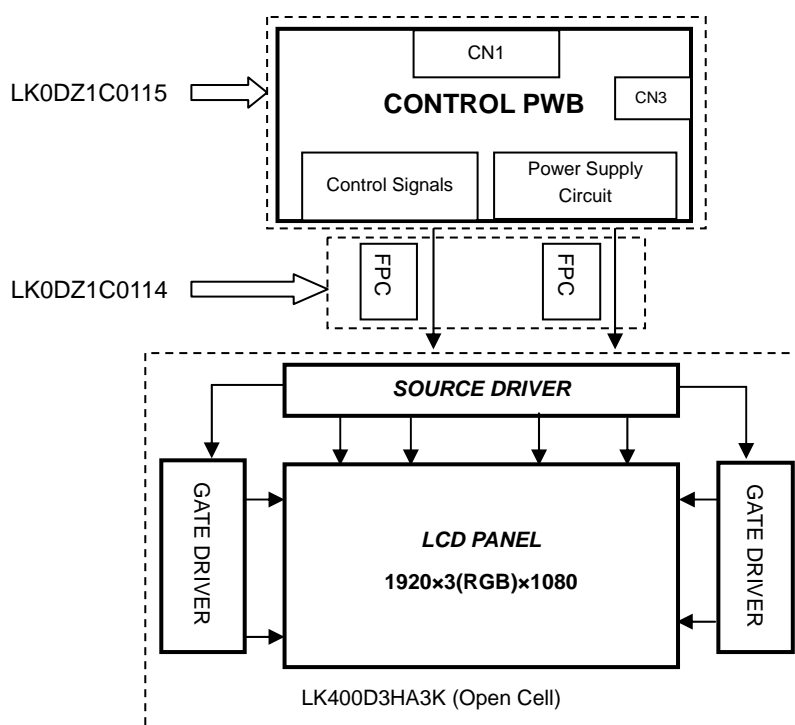

3 Mechanical Specifications

Parameter	Specifications	Unit
Display size	101.609 (Diagonal)	cm
	40.0 (Diagonal)	inch
Active area	885.6(H) x 498.15 (V)	mm
Pixel Format	1920(H) x 1080(V) (1pixel = R + G + B dot)	pixel
Pixel pitch	461.25(H) x 461.25 (V)	um
Pixel configuration	R, G, B vertical stripe	
Display mode	Normally black	
Open Cell Outline Dimensions [Note1]	921.18(H) x 555.7(V) x 1.82(D)	mm
Mass	1.88 ±0.3	kg
Surface treatment[[Note2]	- Front polarizer : Glare Hard coating: 2H and more - Rear polarizer : Hard coating less (B)	

[Note1]Outline Dimensions are shown fig.1

[Note2]With the protection film removed.

4 Open Cell Driving Specifications

4.1 Driving interface of Control PWB SHARP specifies[LK0DZ1C0115]

CN1 (Interface signals and +12V DC power supply)

Using connector : PF050-C82B-C35 (UJU Electronics Co, Ltd.)

Mating LVDS transmitter : THC63LVD1023 or equivalent device

Pin No.	Symbol	Function	Remark
1	VCC	+12V Power Supply	
2	VCC	+12V Power Supply	
3	VCC	+12V Power Supply	
4	VCC	+12V Power Supply	
5	VCC	+12V Power Supply	
6	Reserved	It is required to set non-connection(OPEN)	
7	GND		
8	GND		
9	GND		
10	AIN0-	Aport (-)LVDS CH0 differential data input	
11	AIN0+	Aport (+)LVDS CH0 differential data input	
12	AIN1-	Aport (-)LVDS CH1 differential data input	
13	AIN1+	Aport (+)LVDS CH1 differential data input	
14	AIN2-	Aport (-)LVDS CH2 differential data input	
15	AIN2+	Aport (+)LVDS CH2 differential data input	
16	GND		
17	ACK-	Aport LVDS Clock signal(-)	
18	ACK+	Aport LVDS Clock signal(+)	
19	GND		
20	AIN3-	Aport (-)LVDS CH3 differential data input	
21	AIN3+	Aport (+)LVDS CH3 differential data input	
22	AIN4-	Aport (-)LVDS CH4 differential data input	
23	AIN4+	Aport (+)LVDS CH4 differential data input	
24	GND		
25	CIN0-	Cport (-)LVDS CH0 differential data input	
26	CIN0+	Cport (+)LVDS CH0 differential data input	
27	CIN1-	Cport (-)LVDS CH1 differential data input	
28	CIN1+	Cport (+)LVDS CH1 differential data input	
29	CIN2-	Cport (-)LVDS CH2 differential data input	
30	CIN2+	Cport (+)LVDS CH2 differential data input	

31	GND		
32	CCK-	Cport LVDS Clock signal(-)	
33	CCK+	Cport LVDS Clock signal(+)	
34	GND		
35	CIN3-	Cport (-)LVDS CH3 differential data input	
36	CIN3+	Cport (+)LVDS CH3 differential data input	
37	CIN4-	Cport (-)LVDS CH4 differential data input	
38	CIN4+	Cport (+)LVDS CH4 differential data input	
39	GND		
40	I2C_SCL	I2C CLK	Pull up 3.3V[Note1]
41	Reserved	It is required to set non-connection(OPEN)	
42	Reserved	It is required to set non-connection(OPEN)	
43	WP	I2C bus enable(L/Open:enable, H:disable)	[Note2]
44	I2C_SDA	I2C DATA	Pull up 3.3V[Note1]
45	SELLVDS	Select LVDS data order [Note4]	Pull up 3.3V[Note3]
46	Reserved	It is required to set non-connection(OPEN)	
47	Reserved	It is required to set non-connection(OPEN)	
48	Reserved	It is required to set non-connection(OPEN)	
49	Reserved	It is required to set non-connection(OPEN)	
50	Reserved	It is required to set non-connection(OPEN)	
51	Reserved	It is required to set non-connection(OPEN)	
52	GND		
53	DIN4+	Dport (+)LVDS CH4 differential data input	
54	DIN4-	Dport (-)LVDS CH4 differential data input	
55	DIN3+	Dport (+)LVDS CH3 differential data input	
56	DIN3-	Dport (-)LVDS CH3 differential data input	
57	GND		
58	DCK+	Dport LVDS Clock signal(+)	
59	DCK-	Dport LVDS Clock signal(-)	
60	GND		
61	DIN2+	Dport (+)LVDS CH2 differential data input	
62	DIN2-	Dport (-)LVDS CH2 differential data input	
63	DIN1+	Dport (+)LVDS CH1 differential data input	
64	DIN1-	Dport (-)LVDS CH1 differential data input	
65	DIN0+	Dport (+)LVDS CH0 differential data input	
66	DIN0-	Dport (-)LVDS CH0 differential data input	
67	GND		
68	BIN4+	Bport (+)LVDS CH4 differential data input	
69	BIN4-	Bport (-)LVDS CH4 differential data input	
70	BIN3+	Bport (+)LVDS CH3 differential data input	
71	BIN3-	Bport (-)LVDS CH3 differential data input	
72	GND		
73	BCLK+	Bport LVDS Clock signal(+)	
74	BCLK-	Bport LVDS Clock signal(-)	
75	GND		
76	BIN2+	Bport (+)LVDS CH2 differential data input	
77	BIN2-	Bport (-)LVDS CH2 differential data input	
78	BIN1+	Bport (+)LVDS CH1 differential data input	
79	BIN1-	Bport (-)LVDS CH1 differential data input	
80	BIN0+	Bport (+)LVDS CH0 differential data input	
81	BIN0-	Bport (-)LVDS CH0 differential data input	
82	GND		

[note] GND of a liquid crystal panel drive part should be connected with a module chassis..

[Note 1] The equivalent circuit figure of the terminal

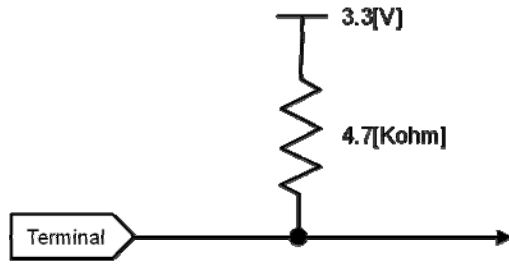

[Note2] The equivalent circuit figure of the terminal

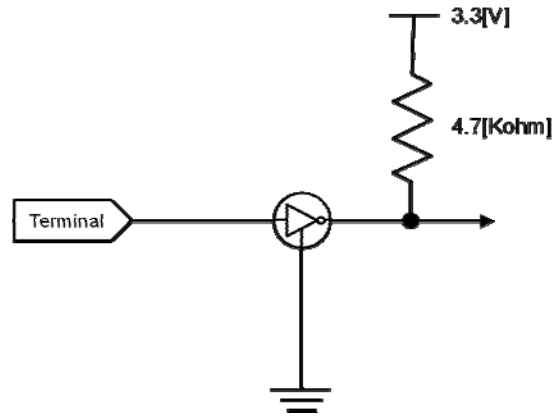

[Note3] The equivalent circuit figure of the terminal

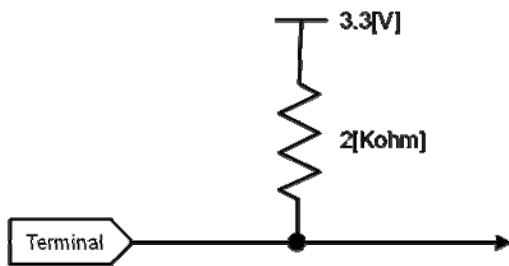

[Note 4] LVDS Data order

SELLVDS		
Data	L(GND) [VESA]	H(3.3V) or Open [JEIDA]
TA0	R0(LSB)	R4
TA1	R1	R5
TA2	R2	R6
TA3	R3	R7
TA4	R4	R8
TA5	R5	R9(MSB)
TA6	G0(LSB)	G4
TB0	G1	G5
TB1	G2	G6
TB2	G3	G7
TB3	G4	G8
TB4	G5	G9(MSB)
TB5	B0(LSB)	B4
TB6	B1	B5
TC0	B2	B6
TC1	B3	B7
TC2	B4	B8
TC3	B5	B9(MSB)
TC4	NA	NA
TC5	NA	NA
TC6	DE(*)	DE(*)
TD0	R6	R2
TD1	R7	R3
TD2	G6	G2
TD3	G7	G3
TD4	B6	B2
TD5	B7	B3
TD6	N/A	N/A
TE0	R8	R0(LSB)
TE1	R9(MSB)	R1
TE2	G8	G0(LSB)
TE3	G9(MSB)	G1
TE4	B8	B0(LSB)
TE5	B9(MSB)	B1
TE6	N/A	N/A

NA: Not Available

(*)Since the display position is prescribed by the rise of DE(Display Enable)signal, please do not fix DE signal during operation at "High".

SELLVDS= Low (GND)

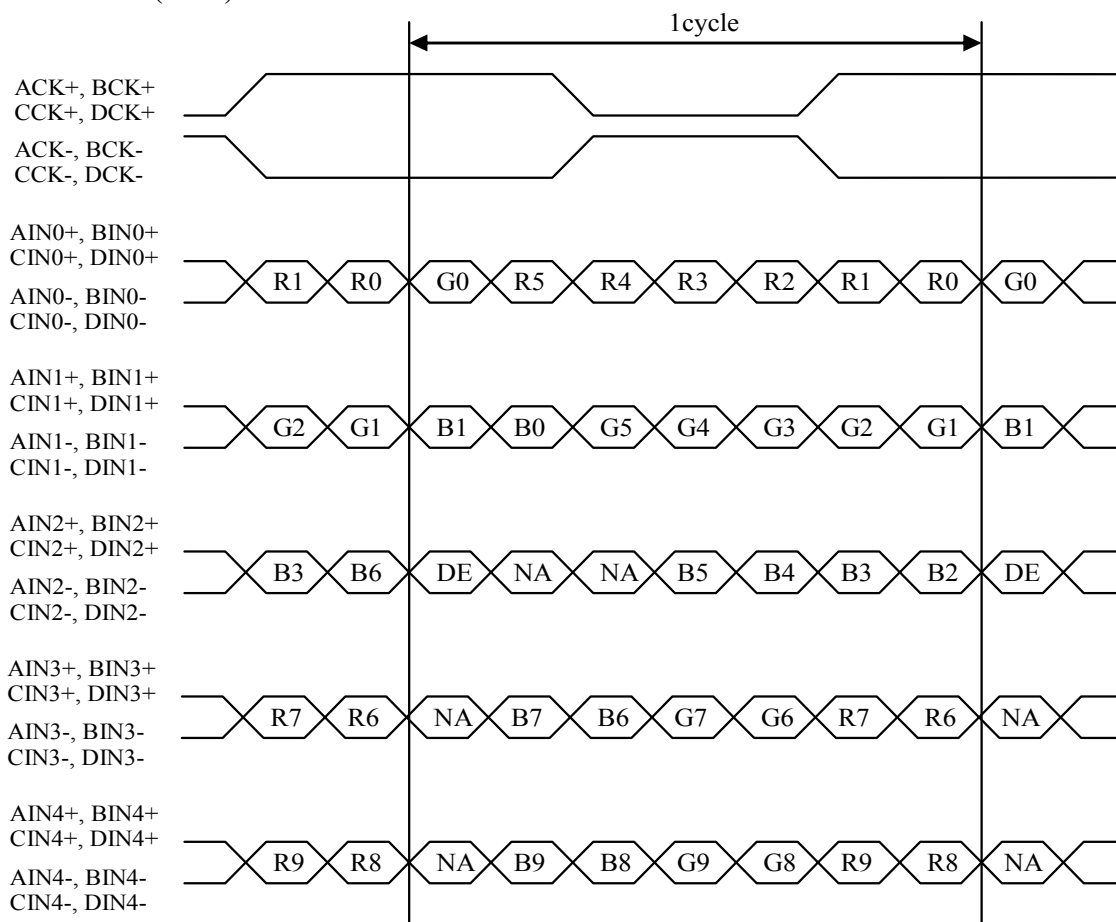

SELLVDS= High (3.3V) or OPEN

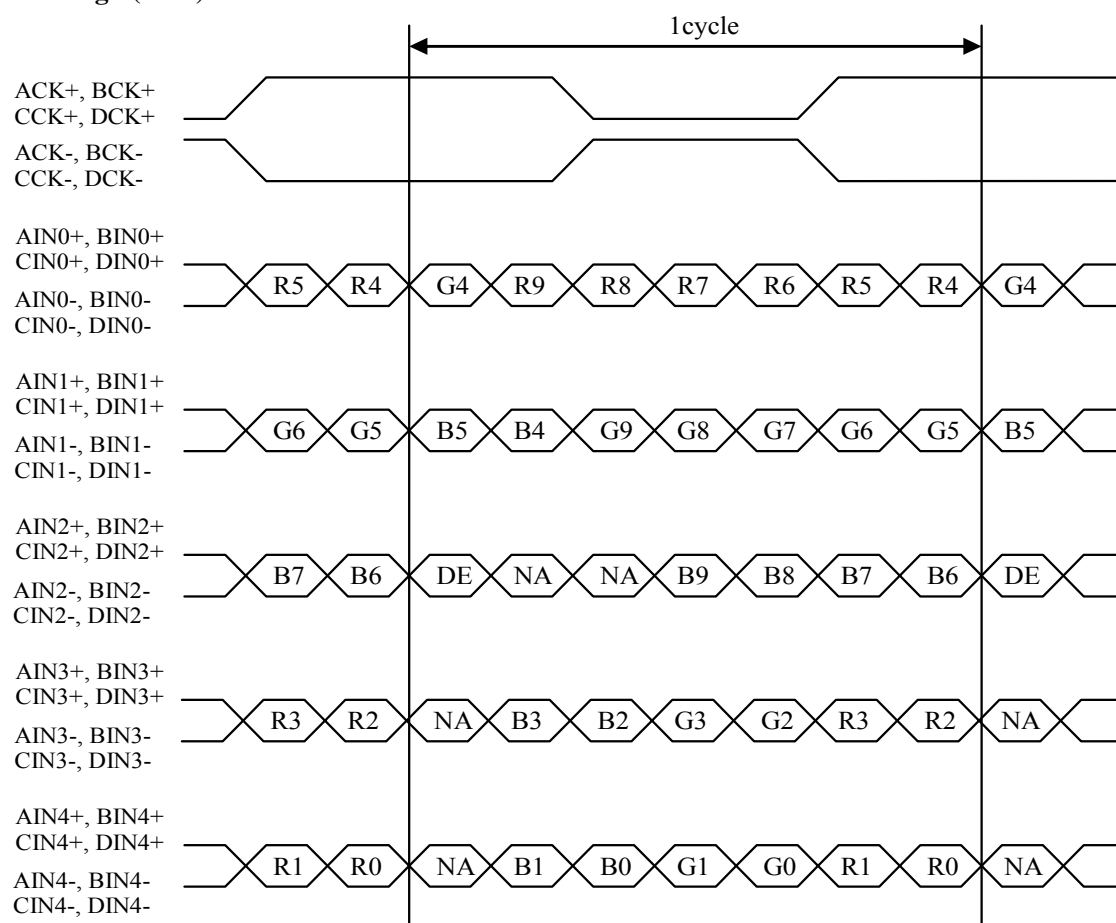

DE: Display Enable, NA: Not Available (Fixed Low)

4.2 Vcom Adjusting interface of Control PWB SHARP specifies[LK0DZ1C0115]

CN3(Interface Vcom Adjusting) [note1]

Interface : 1.5mm Pitch Via Hole(0.7mm phi)

Mating connector : (housing)3P-SZN, (contact)SZN-002T-P0.7K (JST Co.,Ltd.)

Pin No.	Symbol	Function	Remark
1	SDA	I2C DATA	Pull up 3.3V[Note2]
2	SCL	I2C CLK	Pull up 3.3V[Note2]
3	GND		

[Note1]Interface

[Note2] The equivalent circuit figure of the terminal

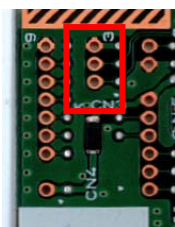

PinNo	Symbol
3	GND
2	SCL
1	SDA

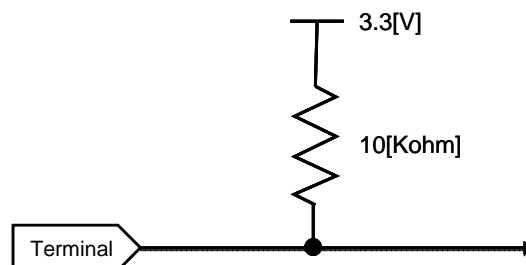

4.3 Absolute Maximum Ratings

Parameter	Symbol	Condition	Ratings	Unit	Remark
Input voltage (for Control)	V_I	$T_a=25\text{ }^\circ\text{C}$	-0.3 ~ 3.6	V	[Note 1]
12V supply voltage (for Control)	VCC	$T_a=25\text{ }^\circ\text{C}$	0 ~ +14	V	
Storage temperature	Tstg	-	-25 ~ +60	$^\circ\text{C}$	[Note 2]
Operation temperature (Ambient)	Topa	-	0 ~ +50	$^\circ\text{C}$	

[Note 1] SELLVDS

[Note 2] Humidity 95%RH Max.($T_a \leq 40^\circ\text{C}$)

Maximum wet-bulb temperature at $39\text{ }^\circ\text{C}$ or less.($T_a > 40^\circ\text{C}$)

No condensation.

4.4 Electrical Characteristics of input signals

$T_a=25\text{ }^\circ\text{C}$

Parameter		Symbol	Min.	Typ.	Max.	Unit	Remark
+12V supply voltage	Supply voltage	Vcc	11.4	12	12.6	V	[Note 1]
	Current dissipation	Icc	-	0.8	2.9	A	[Note 2]
	Inrush current	I_{RUSH1}	-	4.5	-	A	$t_1=500\mu\text{s}$ [Note 6]
		I_{RUSH2}	-	2.5	-	A	$t_1>5\text{ms}$
Permissible input ripple voltage		V_{RP}	-	-	100	mV _{P-P}	$V_{CC} = +12.0\text{V}$
Input Low voltage		V_{IL}	0	-	0.8	V	[Note 3]
Input High voltage		V_{IH}	2.0	-	3.3	V	
Input leak current (Low)		I_{IL1}	-	-	400	μA	$V_I = 0\text{V}$ [Note 4]
Input leak current (High)		I_{IH1}	-	-	400	μA	$V_I = 3.3\text{V}$ [Note 4]
Terminal resistor		R_T	-	100	-	Ohm	Differential input
Input Differential voltage		VID	200	400	600	mV	[Note 5]
Differential input common mode voltage		VCM	VID /2	1.2	2.4- VID /2	V	[Note 5]

[Note] VCM: Common mode voltage of LVDS driver.

[Note 1]

Input voltage sequences

- $0 < t1 < 20ms$
- $20ms < t2 < 5s$
- $20ms < t3 < 5s$
- $0 < t4 < 1s$
- $t5-1 > 1s$
- $t5-2 > 1s$
- $t6-1 > 0$
- $t6-2 > 0$
- $t7 > 1s$

Dip conditions for supply voltage

- a) $V2 \leq Vcc < V1$
 $td < 10ms$
- b) $Vcc < V2$

Dip conditions for supply voltage is based on input voltage sequence.

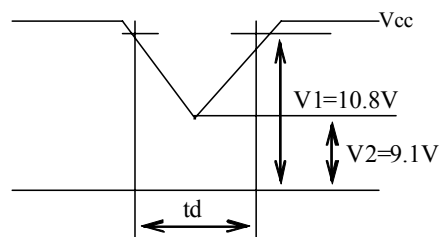
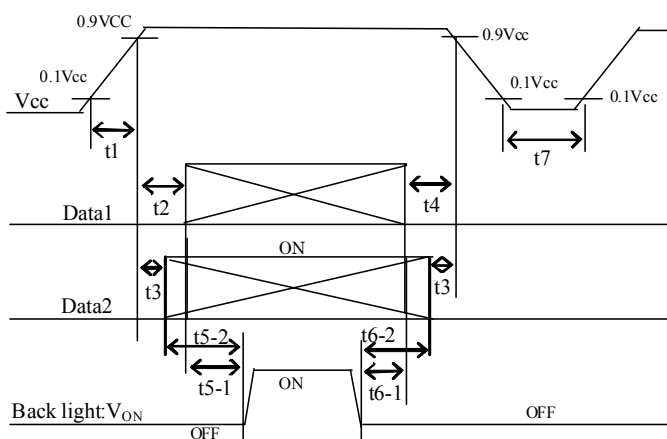

- ※ Data1: ACK±, AIN0±, AIN1±, AIN2±, AIN3±, AIN4±, BCK±, BIN0±, BIN1±, BIN2±, BIN3±, BIN4±, CCK±, CIN0±, CIN1±, CIN2±, CIN3±, CIN4±, DCK±, DIN0±, DIN1±, DIN2±, DIN3±, DIN4±
*V_{CM} voltage pursues the sequence mentioned above
- ※ Data2: SELLVDS, I2C_SCL, I2C_SDA, WP

[Note] About the relation between data input and back light lighting, please base on the above-mentioned input sequence. When back light is switched on before panel operation or after a panel operation stop, it may not display normally. But this phenomenon is not based on change of an incoming signal, and does not give damage to a liquid crystal display.

[Note 2] Typical current situation: 1024 gray-bar patterns. (Vcc = +12.0V)

The explanation of RGB gray scale is seen in section 5.1.

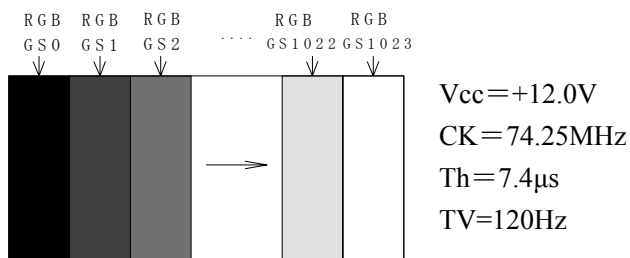

[Note 3] SELLVDS

[Note 4] SELLVDS

[Note 5] ACK±, AIN0±, AIN1±, AIN2±, AIN3±, AIN4±, BCK±, BIN0±, BIN1±, BIN2±, BIN3±, BIN4±, CCK±, CIN0±, CIN1±, CIN2±, CIN3±, CIN4±, DCK±, DIN0±, DIN1±, DIN2±, DIN3±, DIN4±

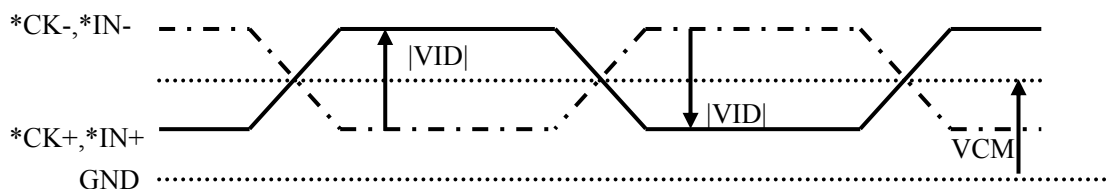

[Note 6] Vcc12V inrush current waveform

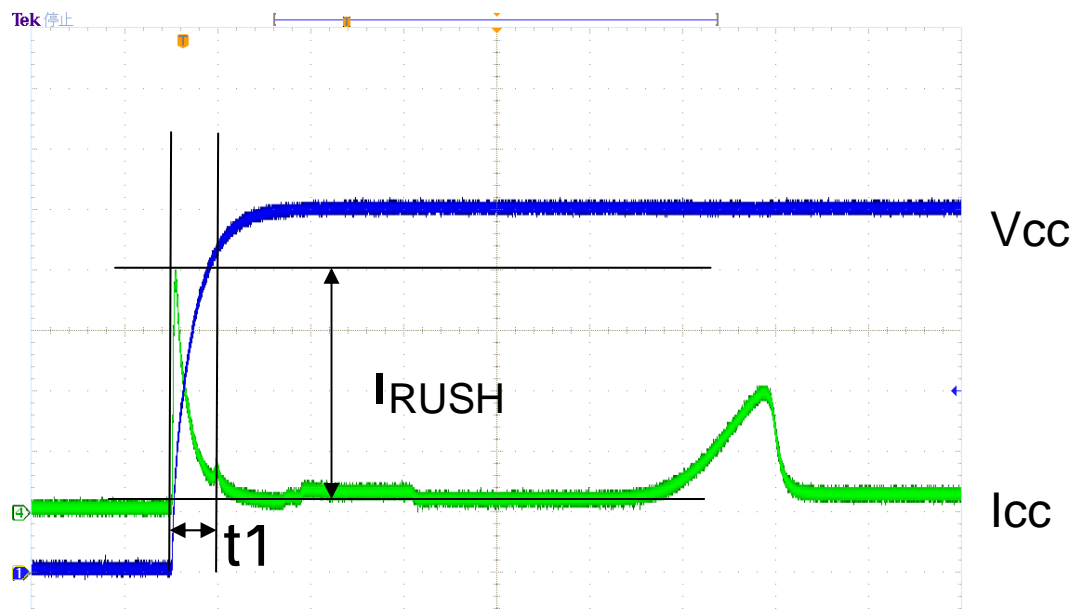

4.5 Timing characteristics of input signals

Timing diagrams of input signal are shown in Fig.2.

Parameter		Symbol	Min.	Typ.	Max.	Unit	Remark
Clock	Frequency	1/Tc	69	74.25	76.0	MHz	
Data enable signal	Horizontal period	TH	542	550	600	clock	
			7.3	7.41	8.1	μs	
	Horizontal period (High)	THd	480	480	480	clock	
	Vertical period	TV	1096	1125	1400	line	
88.2			120	123.1	Hz		
Vertical period (High)	TVd	1080	1080	1080	line		

[Note]-When vertical period is very long, flicker and etc. may occur.

- Please turn off the module after it shows the black screen.
- Please make sure that length of vertical period should become of an integral multiple of horizontal length of period. Otherwise, the screen may not display properly.
- As for your final setting of driving timing, we will conduct operation check test at our side, please inform your final setting.

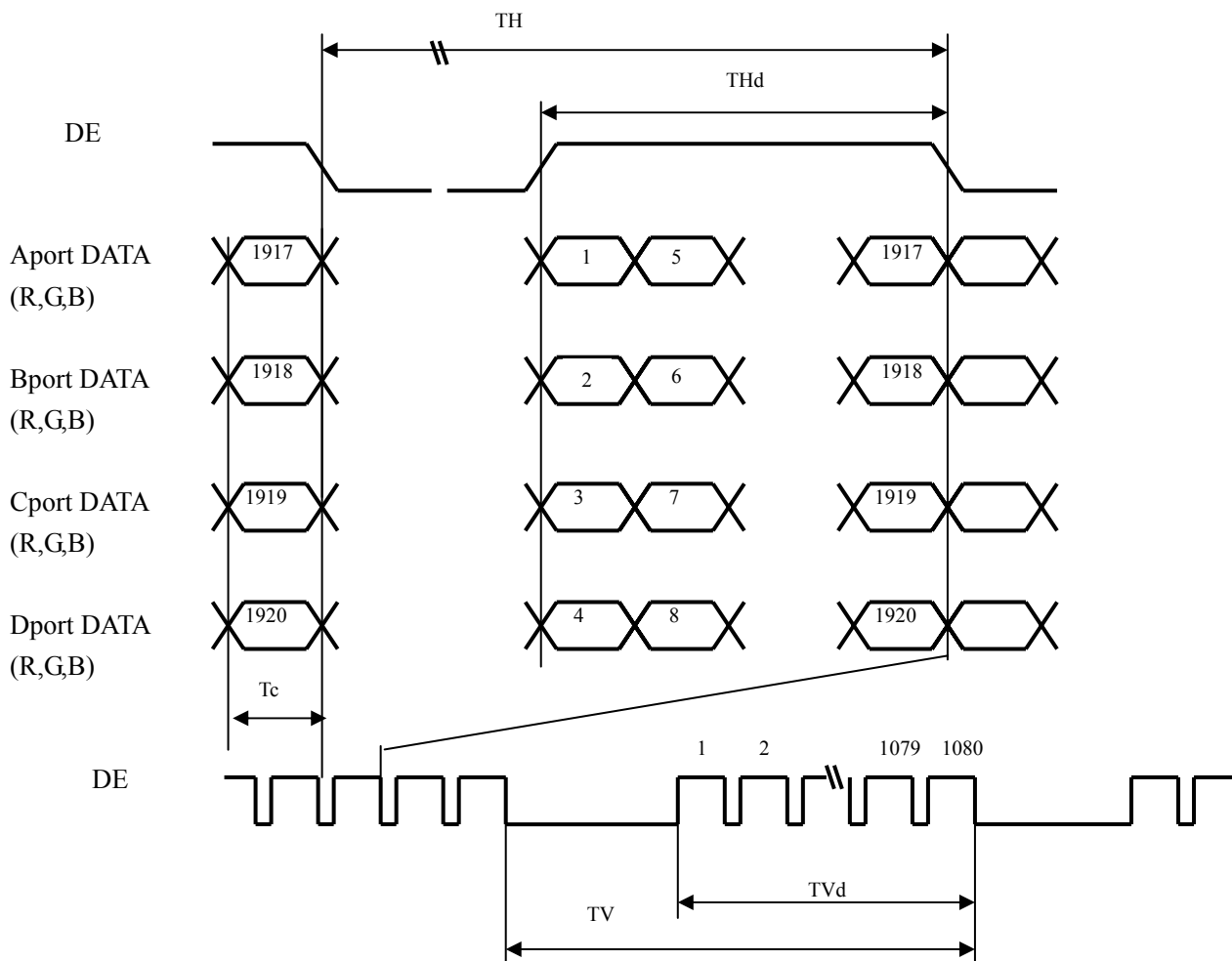
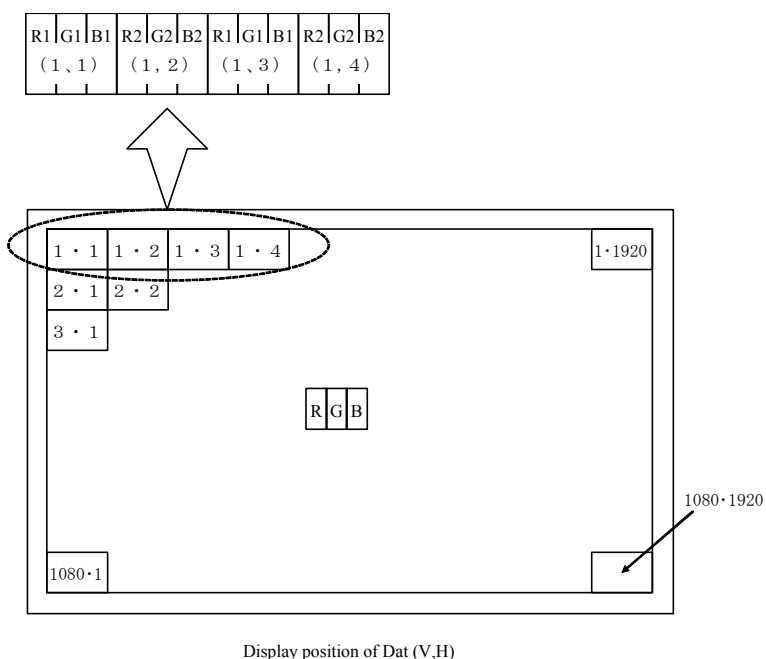

Fig.2.Timing characteristics of input signal

4.6 Input data signal and display position on the screen



Display position of Dat (V,H)

[Note] Scan direction is setting for using S-PWBs' side up. ▲A

4.7 LVDS signal characteristics

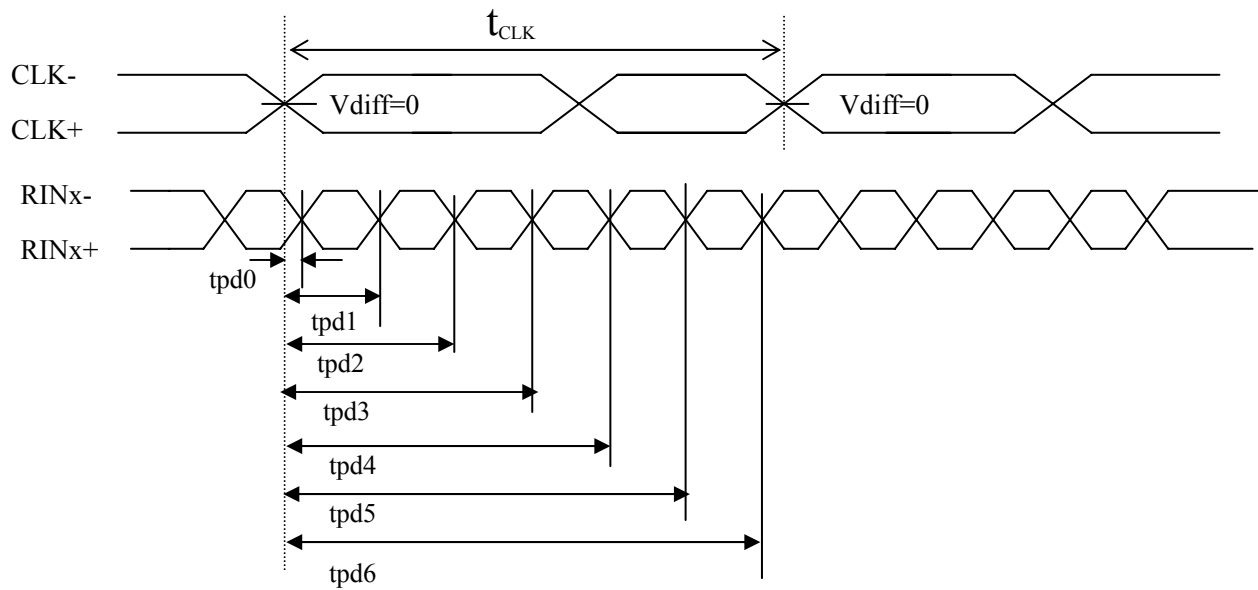

The item		Symbol	min.	typ.	max.	unit
Data position	Delay time, CLK rising edge to serial bit position 0	tpd0	-0.25	0	0.25	ns
	Delay time, CLK rising edge to serial bit position 1	tpd1	$1 * t_{CLK} / 7 - 0.25$	$1 * t_{CLK} / 7$	$1 * t_{CLK} / 7 + 0.25$	
	Delay time, CLK rising edge to serial bit position 2	tpd2	$2 * t_{CLK} / 7 - 0.25$	$2 * t_{CLK} / 7$	$2 * t_{CLK} / 7 + 0.25$	
	Delay time, CLK rising edge to serial bit position 3	tpd3	$3 * t_{CLK} / 7 - 0.25$	$3 * t_{CLK} / 7$	$3 * t_{CLK} / 7 + 0.25$	
	Delay time, CLK rising edge to serial bit position 4	tpd4	$4 * t_{CLK} / 7 - 0.25$	$4 * t_{CLK} / 7$	$4 * t_{CLK} / 7 + 0.25$	
	Delay time, CLK rising edge to serial bit position 5	tpd5	$5 * t_{CLK} / 7 - 0.25$	$5 * t_{CLK} / 7$	$5 * t_{CLK} / 7 + 0.25$	
	Delay time, CLK rising edge to serial bit position 6	tpd6	$6 * t_{CLK} / 7 - 0.25$	$6 * t_{CLK} / 7$	$6 * t_{CLK} / 7 + 0.25$	

5 Optical Specifications

5.1 Input Signal, Basic Display Colors and Gray Scale of Each Color

	Colors & Gray scale	Data signal																																						
		Gray Scale	R0	R1	R2	R3	R4	R5	R6	R7	R8	R9	G0	G1	G2	G3	G4	G5	G6	G7	G8	G9	B0	B1	B2	B3	B4	B5	B6	B7	B8	B9								
Basic Color	Black	–	0	0	0	0	0	0	0	0	0	0	0	0	0	0	0	0	0	0	0	0	0	0	0	0	0	0	0	0	0	0	0	0	0	0	0			
	Blue	–	0	0	0	0	0	0	0	0	0	0	0	0	0	0	0	0	0	0	0	0	0	0	0	0	0	0	0	0	0	0	0	0	0	0	0	0		
	Green	–	0	0	0	0	0	0	0	0	0	0	0	0	0	0	0	0	0	0	0	0	0	0	0	0	0	0	0	0	0	0	0	0	0	0	0	0		
	Cyan	–	0	0	0	0	0	0	0	0	0	0	0	0	0	0	0	0	0	0	0	0	0	0	0	0	0	0	0	0	0	0	0	0	0	0	0	0		
	Red	–	1	1	1	1	1	1	1	1	1	1	1	1	1	1	1	1	1	1	1	1	1	1	1	1	1	1	1	1	1	1	1	1	1	1	1	1		
	Magenta	–	1	1	1	1	1	1	1	1	1	1	1	1	1	1	1	1	1	1	1	1	1	1	1	1	1	1	1	1	1	1	1	1	1	1	1	1		
	Yellow	–	1	1	1	1	1	1	1	1	1	1	1	1	1	1	1	1	1	1	1	1	1	1	1	1	1	1	1	1	1	1	1	1	1	1	1	1	1	
	White	–	1	1	1	1	1	1	1	1	1	1	1	1	1	1	1	1	1	1	1	1	1	1	1	1	1	1	1	1	1	1	1	1	1	1	1	1	1	
	Gray Scale of Red	Black	GS0	0	0	0	0	0	0	0	0	0	0	0	0	0	0	0	0	0	0	0	0	0	0	0	0	0	0	0	0	0	0	0	0	0	0	0		
↑		GS1	1	0	0	0	0	0	0	0	0	0	0	0	0	0	0	0	0	0	0	0	0	0	0	0	0	0	0	0	0	0	0	0	0	0	0	0		
Darker		GS2	0	1	0	0	0	0	0	0	0	0	0	0	0	0	0	0	0	0	0	0	0	0	0	0	0	0	0	0	0	0	0	0	0	0	0	0	0	
↑		↓																																						
↓		↓																																						
Brighter		GS1021	1	0	1	1	1	1	1	1	1	1	1	1	1	1	1	1	1	1	1	1	1	1	1	1	1	1	1	1	1	1	1	1	1	1	1	1		
↓		GS1022	0	1	1	1	1	1	1	1	1	1	1	1	1	1	1	1	1	1	1	1	1	1	1	1	1	1	1	1	1	1	1	1	1	1	1	1	1	
Red		GS1023	1	1	1	1	1	1	1	1	1	1	1	1	1	1	1	1	1	1	1	1	1	1	1	1	1	1	1	1	1	1	1	1	1	1	1	1	1	
Gray Scale of Green	Black	GS0	0	0	0	0	0	0	0	0	0	0	0	0	0	0	0	0	0	0	0	0	0	0	0	0	0	0	0	0	0	0	0	0	0	0	0	0		
	↑	GS1	0	0	0	0	0	0	0	0	0	0	0	0	0	0	0	0	0	0	0	0	0	0	0	0	0	0	0	0	0	0	0	0	0	0	0	0	0	
	Darker	GS2	0	0	0	0	0	0	0	0	0	0	0	0	0	0	0	0	0	0	0	0	0	0	0	0	0	0	0	0	0	0	0	0	0	0	0	0	0	
	↑	↓																																						
	↓	↓																																						
	Brighter	GS1021	0	0	0	0	0	0	0	0	0	0	0	0	0	0	0	0	0	0	0	0	0	0	0	0	0	0	0	0	0	0	0	0	0	0	0	0	0	
	↓	GS1022	0	0	0	0	0	0	0	0	0	0	0	0	0	0	0	0	0	0	0	0	0	0	0	0	0	0	0	0	0	0	0	0	0	0	0	0	0	0
	Green	GS1023	0	0	0	0	0	0	0	0	0	0	0	0	0	0	0	0	0	0	0	0	0	0	0	0	0	0	0	0	0	0	0	0	0	0	0	0	0	0
Gray Scale of Blue	Black	GS0	0	0	0	0	0	0	0	0	0	0	0	0	0	0	0	0	0	0	0	0	0	0	0	0	0	0	0	0	0	0	0	0	0	0	0	0	0	
	↑	GS1	0	0	0	0	0	0	0	0	0	0	0	0	0	0	0	0	0	0	0	0	0	0	0	0	0	0	0	0	0	0	0	0	0	0	0	0	0	
	Darker	GS2	0	0	0	0	0	0	0	0	0	0	0	0	0	0	0	0	0	0	0	0	0	0	0	0	0	0	0	0	0	0	0	0	0	0	0	0	0	0
	↓	↓																																						
	↓	↓																																						
	Brighter	GS1021	0	0	0	0	0	0	0	0	0	0	0	0	0	0	0	0	0	0	0	0	0	0	0	0	0	0	0	0	0	0	0	0	0	0	0	0	0	
	↓	GS1022	0	0	0	0	0	0	0	0	0	0	0	0	0	0	0	0	0	0	0	0	0	0	0	0	0	0	0	0	0	0	0	0	0	0	0	0	0	0
	Blue	GS1023	0	0	0	0	0	0	0	0	0	0	0	0	0	0	0	0	0	0	0	0	0	0	0	0	0	0	0	0	0	0	0	0	0	0	0	0	0	0

0: Low level voltage, 1: High level voltage.

Each basic color can be displayed in 1024 gray scales from 10 bits data signals. According to the combination of total 30 bits data signals, one billion-color display can be achieved on the screen.

6 Optical Specifications

6.1 Optical characteristics ▲A

Ta=25°C, Vcc=12.0V, Timing:120Hz(typ. value)

Parameter		Symbol	Condition	Min.	Typ.	Max.	Unit	Remark
Viewing angle range	Horizontal	θ_{21} θ_{22}	$CR \geq 10$	70	88	-	Deg.	[Note1,4]
	Vertical	θ_{11} θ_{12}		70	88	-	Deg.	
Contrast ratio		CRn	$\theta = 0 \text{ deg.}$	3200	4000	-	-	[Note2,4]
Response time		τ_{DRV}			4		ms	[Note3,4,5]
Chromaticity	White	x		Typ.-0.03	(0.270)	Typ.+0.03	-	[Note 4,7]
		y		Typ.-0.03	(0.280)	Typ.+0.03	-	
	Red	x		Typ.-0.03	(0.650)	Typ.+0.03	-	
		y		Typ.-0.03	(0.340)	Typ.+0.03	-	
	Green	x		Typ.-0.03	(0.282)	Typ.+0.03	-	
		y		Typ.-0.03	(0.635)	Typ.+0.03	-	
	Blue	x		Typ.-0.03	(0.145)	Typ.+0.03	-	
		y		Typ.-0.03	(0.060)	Typ.+0.03	-	
Luminance	White	Y_L	400	450	-	cd/m ²	[Note 4]	
Luminance uniformity	White	δ_w	-	-	(1.34)		[Note 6,7]	

-Optical characteristics (except Note7) are based on SHARP standard module (CCFL)

-The measurement shall be executed 60 minutes after lighting at rating.

[Note]The optical characteristics are measured using the following equipment.

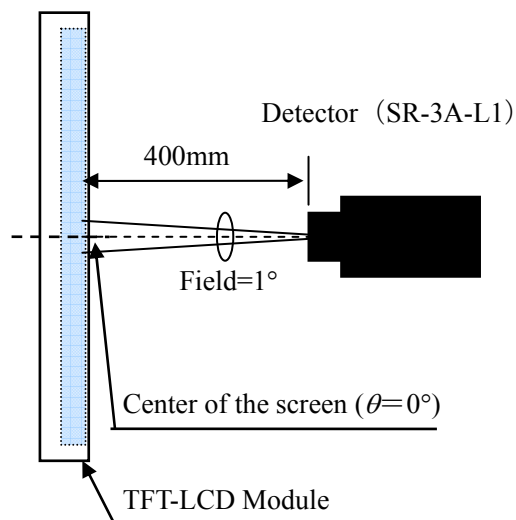
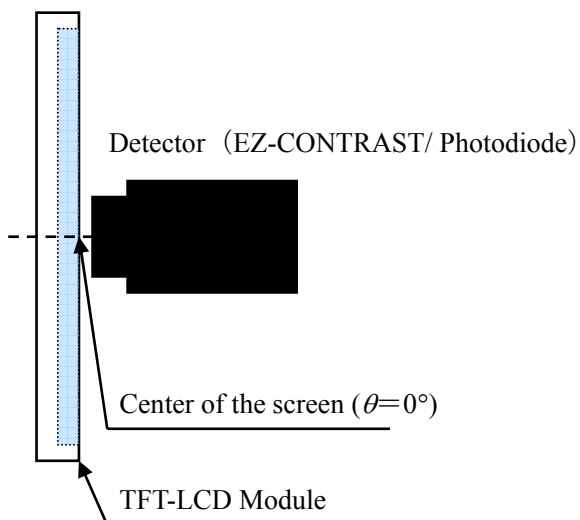
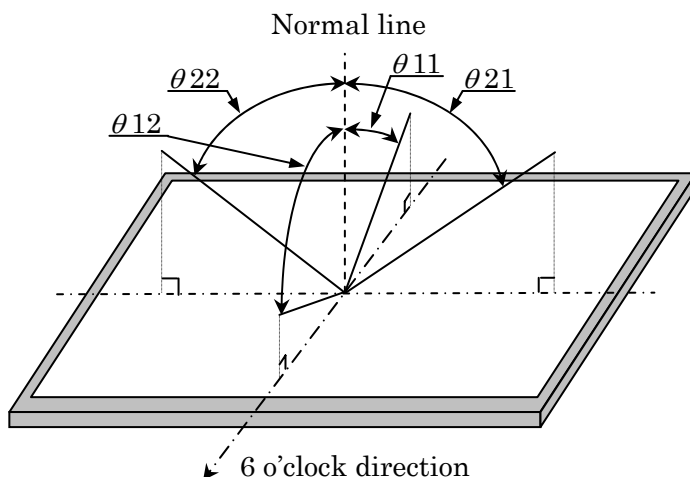

Fig.4-1 Measurement of viewing angle range and Response time.

Viewing angle range: EZ-CONTRAST

Response time: Photodiode

[Note 1]Definitions of viewing angle range :



[Note 2]Definition of contrast ratio :

The contrast ratio is defined as the following.

$$\text{Contrast Ratio} = \frac{\text{Luminance (brightness) with all pixels white}}{\text{Luminance (brightness) with all pixels black}}$$

[Note 3]Definition of response time

The response time (τ_d and τ_r) is defined as the following figure and shall be measured by switching the input signal for “any level of gray (0%, 25%, 50%, 75% and 100%)” and “any level of gray (0%, 25%, 50%, 75% and 100%)”.

	0%	25%	50%	75%	100%
0%		tr: 0%-25%	tr: 0%-50%	tr: 0%-75%	tr: 0%-100%
25%	td: 25%-0%		tr: 25%-50%	tr: 25%-75%	tr: 25%-100%
50%	td: 50%-0%	td: 50%-25%		tr: 50%-75%	tr: 50%-100%
75%	td: 75%-0%	td: 75%-25%	td: 75%-50%		tr: 75%-100%
100%	td: 100%-0%	td: 100%-25%	td: 100%-50%	td:100%-75%	

t*:x-y...response time from level of gray(x) to level of gray(y)

$$\tau_r = \Sigma(\text{tr}:x-y)/10, \tau_d = \Sigma(\text{td}:x-y)/10$$

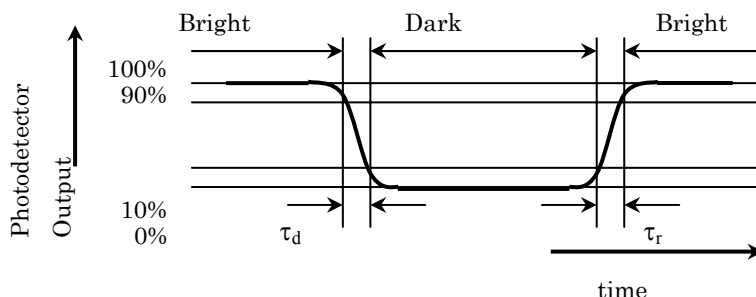

[Note 4]This shall be measured at center of the screen.

[Note 5] This value is valid when O/S driving is used at typical input time value.

[Note 6] This value is calculated as the following with nine measurements. (1~9) ▲A

$$\delta_w = \frac{\text{Maximum luminance of nine points (brightness)}}{\text{Minimum luminance of nine points (brightness)}}$$

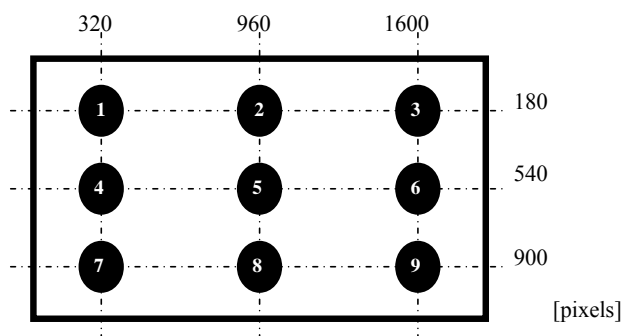

[Note7] This value is reference based on measurement result by SEC backlight system. ▲A

7 Packing for shipping

7.1 Packing form

- a) Piling number of cell boxes : 14cell box/1 palette
- b) Packing quantity in one cell box : 10pcs.
- c) Carton size : 1360(W)×1120(D)×1063(H)
- d) Total mass of one carton filled with full Open Cell : 358.4kg Max

7.2 Label

- a) Open Cell Label

This label is stuck on the protection film of front polarizer.

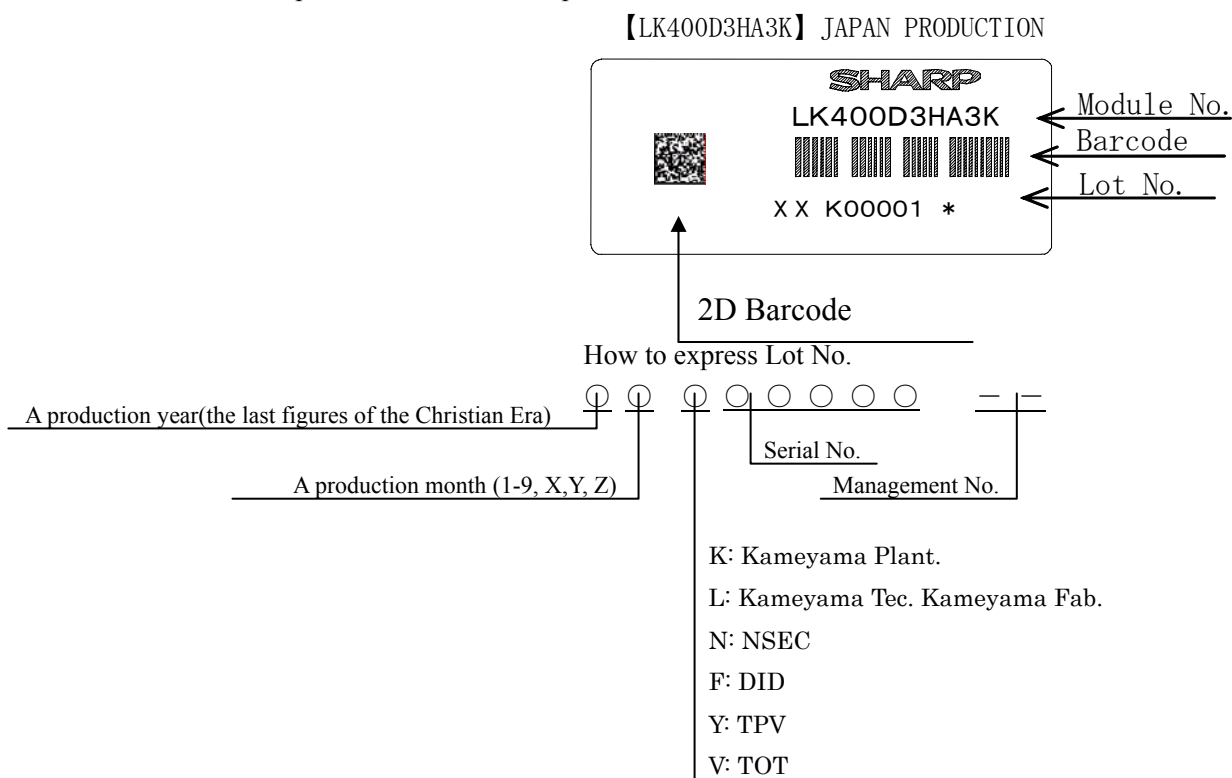

b) Packing Label

This Label is stuck on the packing case(cell box) and carton.

[LK400D3HA3K*]

b-1)Cell box

社内品番:(4 S) LK400D3HA3K*	
Bar code (①)	
Lot NO. (1 T) 200*. *.*	
Bar code (②)	
Quantity:(Q)	p c s
Bar code (③)	
ユーザ品番	
シャープ物流用ラベルです。	

b-2)Carton

社内品番:(4 S) LK400D3HA3K*	
Bar code (①)	
Lot NO. (1 T) 200*. *.*	
Bar code (②)	
Quantity:(Q)	p c s
Bar code (③)	
ユーザ品番	
シャープ物流用ラベルです。	

① Management No.

② Lot No. (Date)

③ Quantity

8 Reliability ▲A

Reliability test item

No.	Test item	Condition
1	High temperature storage test (Open Cell)	Ta = 60°C 240h
2	Low temperature storage test (Open Cell)	Ta = -25°C 240h
3	High temperature and high humidity operation test (Open Cell)	Ta = 40°C 95%RH 240h (No condensation)
4	High temperature operation test (Open Cell)	Ta = 50°C 240h
5	Low temperature operation test (Open Cell)	Ta = 0°C 240h
6	Vibration test (Cell Box with full Open Cells)	X and Y direction: 15min, Z direction: 60min. 5Hz to 50Hz acceleration velocity: 1.0G Sweeping ratio: 3min
7	Drop test (Cell Box with full Open Cells)	Height: 25cm (corner and edge), 32cm (surface) Number: 8times (corner 1time and edge 3times and surface 4times)

[Result evaluation criteria]

Under the display quality test condition with normal operation state, there shall be no change, which may affect practical display function.

9 Handling Precautions of the Open Cell

- a) Be sure to turn off the power supply when inserting or disconnecting the cable.
 - b) Be sure to design the LCD module and cabinet so that the Open Cell can be installed without any extra stress such as warp or twist.
 - c) Since the polarizer is easily damaged, pay attention not to scratch it.
 - d) Since long contact with water may cause discoloration or spots, wipe off water drop immediately.
 - e) When the panel surface is soiled, wipe it with absorbent cotton or other soft cloth.
 - f) Since the panel is made of glass, it may break or crack if dropped or bumped on hard surface. Handle with care.
- g) Since an open cell consists of a TFT cell and electronic circuits with CMOS-ICs, which are very weak to electrostatic discharge, persons who are handling an open cell should be grounded through adequate methods such as an anti-static wrist band. Connector pins should not be touched directly with bare hands.

• Reference : Process control standard of sharp

	item	Management standard value and performance standard
1	Anti-static mat(shelf)	1 to 50 [Mega ohm]
2	Anti-static mat(floor,desk)	1 to 100 [Mega ohm]
3	Ionizer	Attenuate from $\pm 1000V$ to $\pm 100V$ within two seconds.
4	Anti-static wrist band	0.8 to 10 [Mega ohm]
5	Anti-static wrist band entry and ground resistance	Below 1000 [ohm]
6	Temperature	22 to 26 [°C]
7	Humidity	60 to 70 [%RH]

- h) The Open Cell has some PWBs, take care to keep them from any stress or pressure when handling or installing the Open Cell; otherwise some of electronic parts on the PWBs may be damaged.
- i) When handling LCD modules and assembling them into cabinets, please be noted that long-term storage in the environment of oxidization or deoxidization gas and the use of such materials as reagent, solvent, adhesive, resin, etc. which generate these gasses, may cause corrosion and discoloration of the LCD Open Cell.
- j) Observe all other precautionary requirements in handling components.
- k) Applying too much force and stress to PWB and SOF may cause a malfunction electrically and mechanically.
- l) The TFT open cell has high frequency circuits. Sufficient suppression to EMI should be done by system manufacturers.
- m) When you peel the protection film for a polarizer.

• The protection film should be peeled as Fig.3

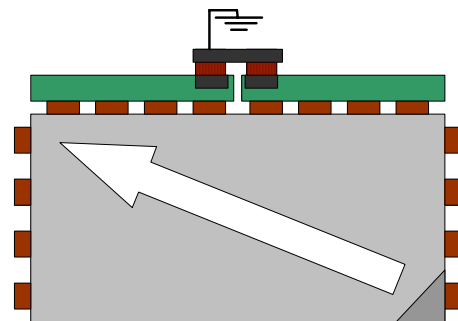

Fig.3 Direction peeled off

- Slowly(Recommendation : more than 5[sec]) & constant speed
- Persons who are electrically grounded with adequate methods such as an anti-static wrist band.
- Ionized air should be blown over the during peeling action..
- Ground S-PWB connectors while peeling of a protection film.
- The protection film must not touch SOFs.

- Please remove with isopropyl-alcohol if adhesive may remain on a polarizer after a protection film is peeled off.
- n) Electrical components which may not affect electrical performance are subjective to change without notice because of their availability.
- o) Please be careful since image retention may occur when a fixed pattern is displayed for a long time.
- p) The chemical compound, which causes the destruction of ozone layer, is not being used.
- q) This Open Cell is corresponded to RoHS. "R.C." label on the side of palette shows it.
- r) When any question or issue occurs, it shall be solved by mutual discussion.

10 Carton storage condition.

Temperature	0°C to 40°C
Humidity	95%RH or less
Reference condition	: 20°C to 35°C, 85%RH or less (summer) : 5°C to 15°C, 85%RH or less (winter) · the total storage time (40°C, 95%RH) : 240H or less
Sunlight	Be sure to shelter a product from the direct sunlight.
Atmosphere	Harmful gas, such as acid and alkali which bites electronic components and/or wires must not be detected.
Notes	Be sure to put cartons on palette or base, don't put it on floor, and store them with removing from wall Please take care of ventilation in storehouse and around cartons, and control changing temperature is within limits of natural environment
Storage life	1 year

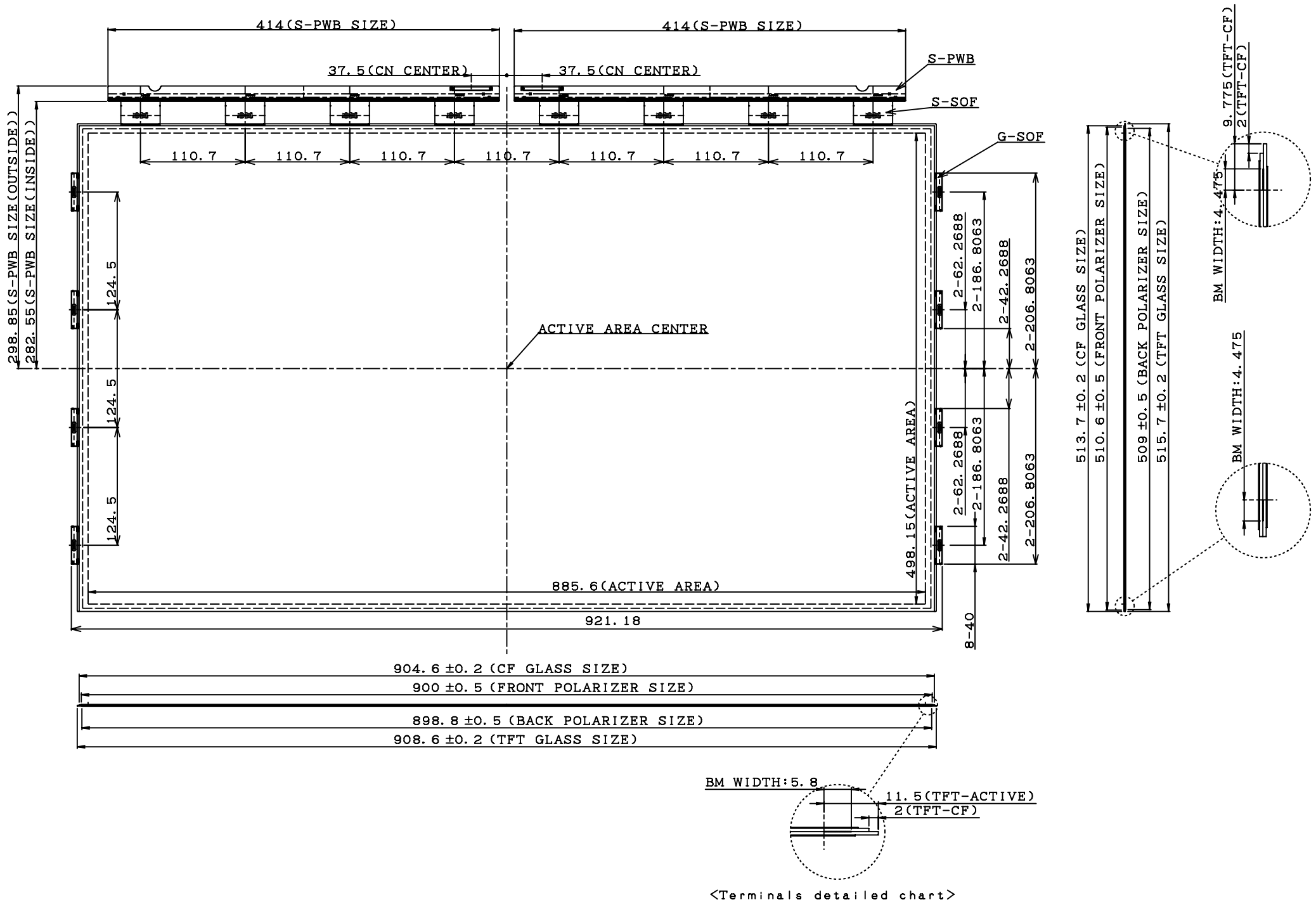
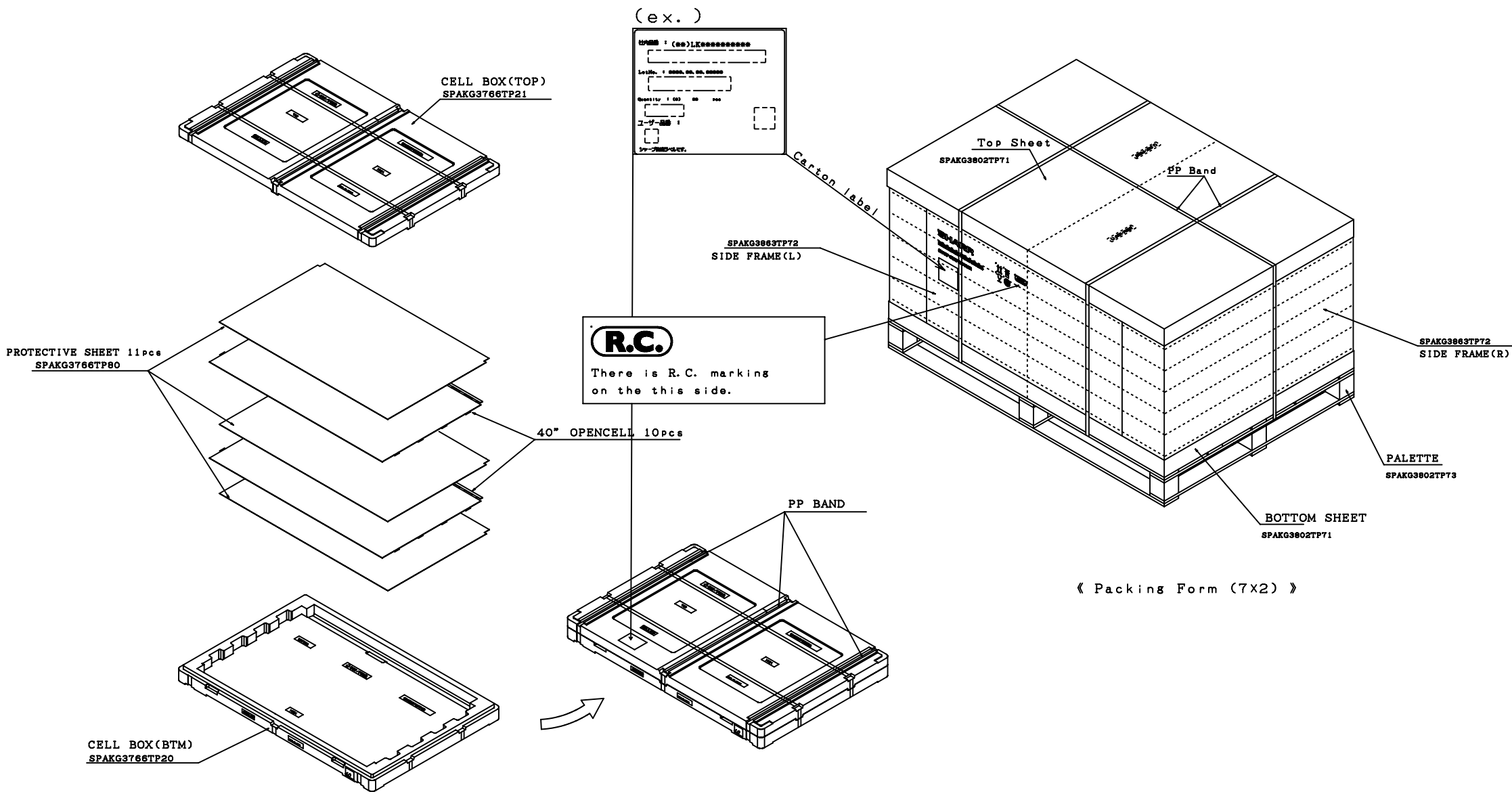

FIG1. TFT-LCD OPENCCELL OUTLINE DIMENSIONS

LK400D3HA3K



40INCH OPENCELL Packing Form