



PREPARED BY: _____	DATE _____	SHARP	SPEC No. LD-K23510
APPROVED BY: _____	DATE _____		FILE No. _____
			ISSUE: May, 24, 2011
			PAGE :22 pages
		LIQUID CRYSTAL DISPLAY GROUP SHARP CORPORATION SPECIFICATION	APPLICABLE GROUP LARGE LIQUID CRYSTAL DISPLAY DISPLAY BUSINESS GROUP

DEVICE SPECIFICATION FOR

TFT-LCD Cell

MODEL No. LK460D3HB29

CUSTOMER'S APPROVAL

DATE _____

BY _____

PRESENTED

By

K. Tanaka

K.TANAKA

GENERAL MANAGER

LIQUID CRYSTAL DISPLAY DIVISION

LARGE LIQUID CRYSTAL DISPLAY BUSINESS GROUP

SHARP CORPORATION

1. Application

This specification applies to the color 46.0" TFT-LCD Open Cell LK460D3HB29.

* This specification is proprietary products of SHARP CORPORATION ("SHARP") and includes materials protected under copyright of SHARP. Do not reproduce or cause any third party to reproduce them in any form or by any means, electronic or mechanical, for any purpose, in whole or in part, without the express written permission of SHARP.

* In case of using the device for applications such as control and safety equipment for transportation (aircraft, trains, automobiles, etc.), rescue and security equipment and various safety related equipment which require higher reliability and safety, take into consideration that appropriate measures such as fail-safe functions and redundant system design should be taken.

* Do not use the device for equipment that requires an extreme level of reliability, such as aerospace applications, telecommunication equipment (trunk lines), nuclear power control equipment and medical or other equipment for life support.

* SHARP assumes no responsibility for any damage resulting from the use of the device that does not comply with the instructions and the precautions specified in these specification.

* Contact and consult with a SHARP sales representative for any questions about this device.

2. Overview

This Open Cell is color active matrix LCD Open Cell incorporating amorphous silicon TFT (Thin Film Transistor). It is composed of a color TFT-LCD panel, driver ICs and Source PWB.

The following contents can be achieved in using LK0DZ1C0321 (C-PWB) and LK0DZ1C0112 (CS-FPC) that SHARP specifies.

Graphics and texts can be displayed on a $1920 \times \text{RGB} \times 1080$ dots panel with one billion colors by using 10bit (8bit+2FRC) LVDS (Low Voltage Differential Signaling) to interface, +12V of DC supply voltages.

And in order to improve the response time of LCD, this module applies the Over Shoot driving (O/S driving) technology for the control circuit. In the O/S driving technology, signals are being applied to the Liquid Crystal according to a pre-fixed process as an image signal of the present frame when a difference is found between image signal of the previous frame and that of the current frame after comparing them.

With combination of these technologies, motion blur can be reduced and clearer display performance can be realized.

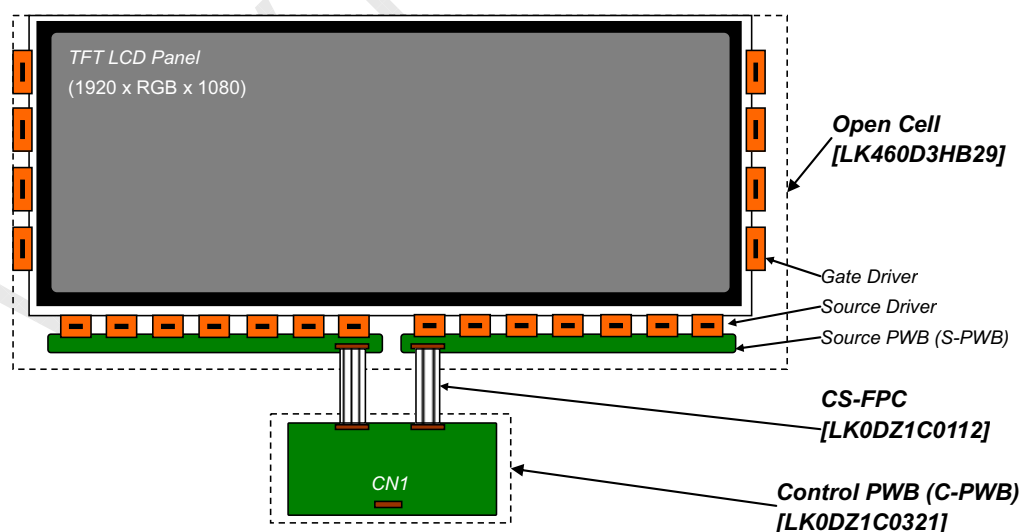

3. Mechanical Specifications

Parameter	Specifications	Unit
Display size	116.809 (Diagonal)	cm
	46.0 (Diagonal)	inch
Active area	1018.08(H) x 572.67 (V)	mm
Pixel Format	1920 (H) x 1080 (V) (1pixel = R + G + B dot)	pixel
Pixel pitch	0.530(H) x 0.530 (V)	mm
Pixel configuration	R, G, B vertical stripe	
Display mode	Normally black	
Open Cell Outline Dimensions [Note1]	1064.58 (W) x 630.85 (H) x 1.82 (D)	mm
Mass	2.5	kg
Surface treatment [Note2]	- Front polarizer : Anti Glare, Low Haze Hard coating: 2H or more - Rear polarizer : Hard coating less	

[Note1] Outline dimensions are shown in P21.

[Note2] With the protection film removed.

4. Open Cell Driving Specifications

4.1. Driving interface of C-PWB SHARP specifies [LK0DZ1C0321]

CN1 (Interface signals and +12V DC power supply)

Using connector : FI-RE51S-HF (Japan Aviation Electronics Ind., Ltd.)

Matching connector : FI-RE51HL, FI-RE51CL (Japan Aviation Electronics Ind., Ltd.) or equivalent device

Matching LVDS transmitter : THC63LVD1023 or equivalent device

Pin No.	Symbol	Function	Remark
1	GND		
2	Reserved	It is required to set non-connection(OPEN)	
3	Reserved	It is required to set non-connection(OPEN)	
4	Reserved	It is required to set non-connection(OPEN)	
5	Reserved	It is required to set non-connection(OPEN)	
6	Reserved	It is required to set non-connection(OPEN)	
7	SELLVDS	Select LVDS data order [Note1,2]	Pull up : (3.3V)
8	Reserved	It is required to set non-connection(OPEN)	
9	Reserved	It is required to set non-connection(OPEN)	
10	FRAME	Frame frequency setting 1:60Hz 0:50Hz [Note3]	Pull down : GND
11	GND		
12	AIN0-	Aport (-)LVDS CH0 differential data input	
13	AIN0+	Aport (+)LVDS CH0 differential data input	
14	AIN1-	Aport (-)LVDS CH1 differential data input	
15	AIN1+	Aport (+)LVDS CH1 differential data input	
16	AIN2-	Aport (-)LVDS CH2 differential data input	
17	AIN2+	Aport (+)LVDS CH2 differential data input	
18	GND		
19	ACK-	Aport LVDS Clock signal(-)	
20	ACK+	Aport LVDS Clock signal(+)	
21	GND		
22	AIN3-	Aport (-)LVDS CH3 differential data input	
23	AIN3+	Aport (+)LVDS CH3 differential data input	
24	AIN4-	Aport (-)LVDS CH4 differential data input	
25	AIN4+	Aport (+)LVDS CH4 differential data input	
26	GND		
27	GND		
28	BIN0-	Bport (-)LVDS CH0 differential data input	
29	BIN0+	Bport (+)LVDS CH0 differential data input	
30	BIN1-	Bport (-)LVDS CH1 differential data input	
31	BIN1+	Bport (+)LVDS CH1 differential data input	
32	BIN2-	Bport (-)LVDS CH2 differential data input	
33	BIN2+	Bport (+)LVDS CH2 differential data input	
34	GND		
35	BCK-	Bport LVDS Clock signal(-)	
36	BCK+	Bport LVDS Clock signal(+)	
37	GND		
38	BIN3-	Bport (-)LVDS CH3 differential data input	
39	BIN3+	Bport (+)LVDS CH3 differential data input	
40	BIN4-	Bport (-)LVDS CH4 differential data input	
41	BIN4+	Bport (+)LVDS CH4 differential data input	
42	GND		
43	GND		
44	GND		
45	GND		
46	GND		
47	VCC	+12V Power Supply	
48	VCC	+12V Power Supply	
49	VCC	+12V Power Supply	
50	VCC	+12V Power Supply	
51	VCC	+12V Power Supply	

[Note] GND of a liquid crystal panel drive part has connected with a module chassis.

[Note 1] The equivalent circuit figure of the terminal

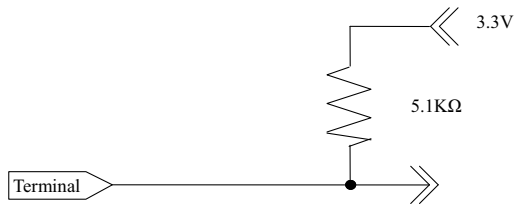

[Note 3] The equivalent circuit figure of the terminal

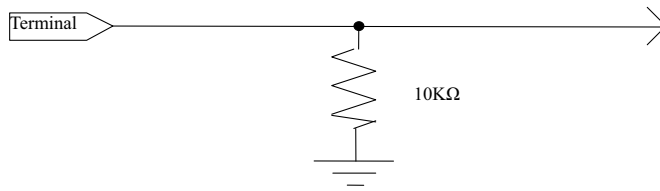

www.panelook.com

[Note 2] LVDS Data order

SELLVDS		
Data	L(GND) VESA	H(3.3V) or Open JEIDA
TA0	R0(LSB)	R4
TA1	R1	R5
TA2	R2	R6
TA3	R3	R7
TA4	R4	R8
TA5	R5	R9(MSB)
TA6	G0(LSB)	G4
TB0	G1	G5
TB1	G2	G6
TB2	G3	G7
TB3	G4	G8
TB4	G5	G9(MSB)
TB5	B0(LSB)	B4
TB6	B1	B5
TC0	B2	B6
TC1	B3	B7
TC2	B4	B8
TC3	B5	B9(MSB)
TC4	NA	NA
TC5	NA	NA
TC6	DE(*)	DE(*)
TD0	R6	R2
TD1	R7	R3
TD2	G6	G2
TD3	G7	G3
TD4	B6	B2
TD5	B7	B3
TD6	NA	NA
TE0	R8	R0(LSB)
TE1	R9(MSB)	R1
TE2	G8	G0(LSB)
TE3	G9(MSB)	G1
TE4	B8	B0(LSB)
TE5	B9(MSB)	B1
TE6	NA	NA

NA: Not Available

(*)Since the display position is prescribed by the rise of DE(Display Enable)signal, please do not fix DE signal during operation at "High".

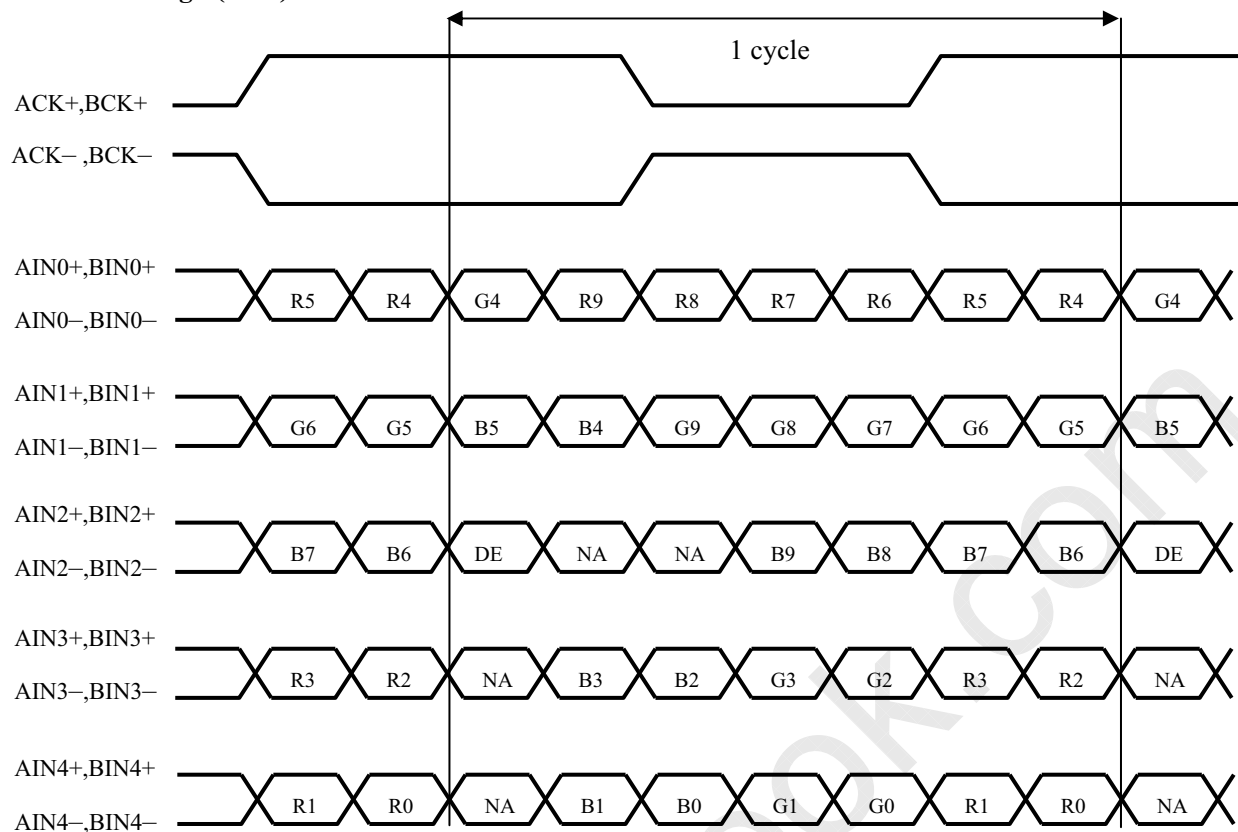
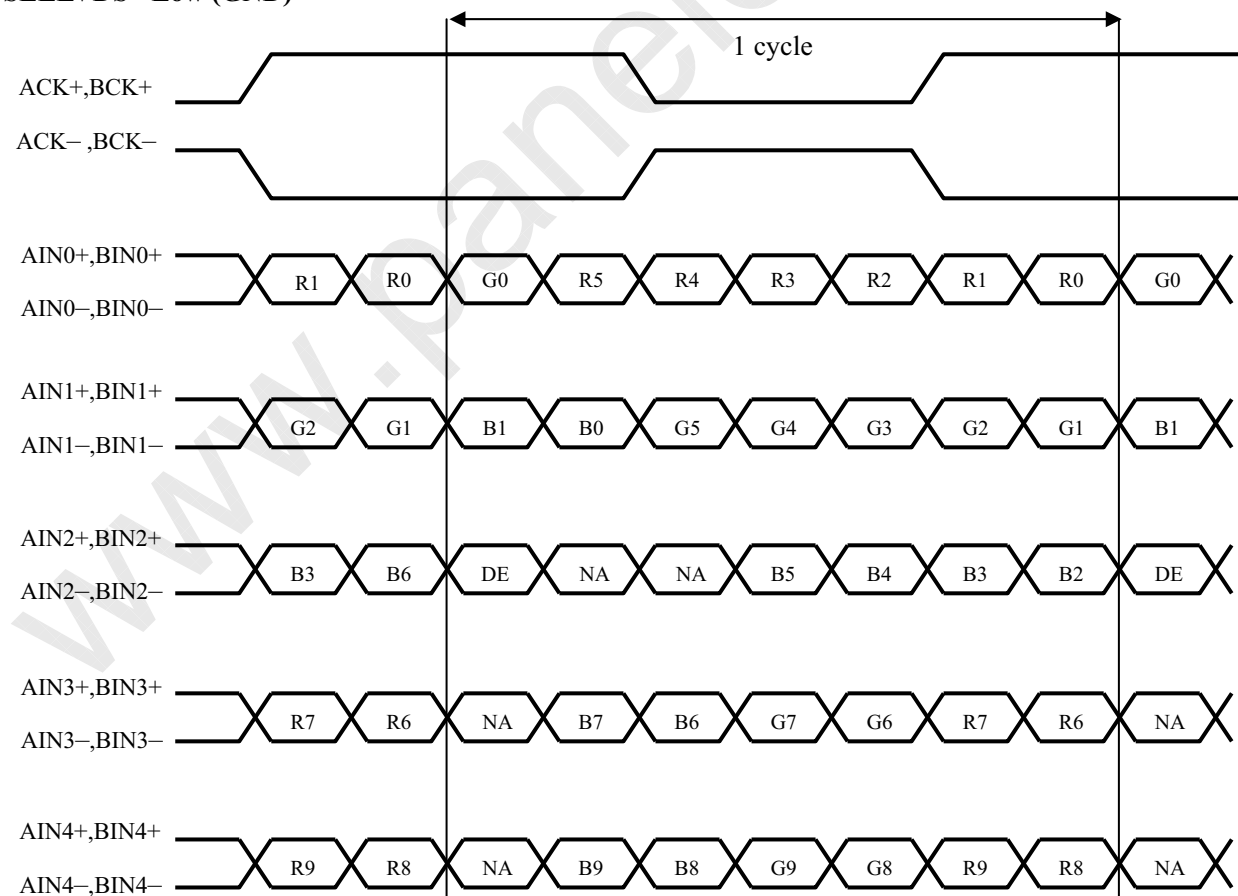
SELLVDS= High (3.3V) or OPEN**SELLVDS= Low (GND)**

DE: Display Enable, NA: Not Available (Fixed Low)

•Interface block diagram

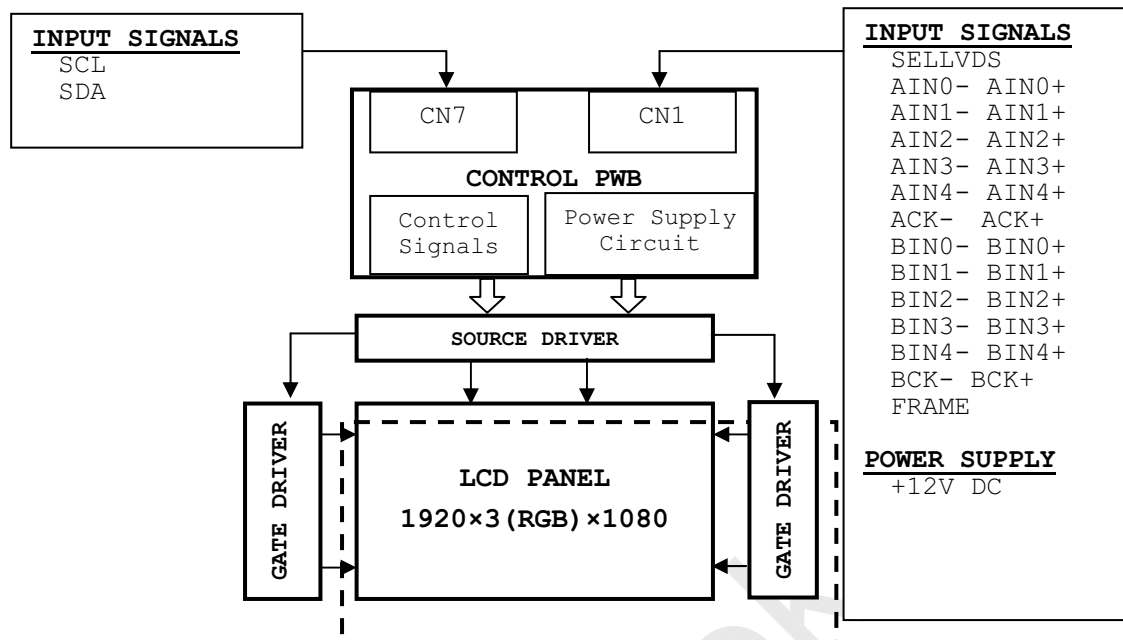

4.2. Vcom adjustment

For the prevention of long-time image sticking of TFT-LCD panel, be sure to adjust Vcom flicker to be minimized on the center of display by visual or flicker meter.

- Vcom IC: Intersil(ISL24837) control from CN7[Note].
- Adjustment pattern:

V0	V512	V0	V512	V0	V512	V0	V512	V0
V512	V0	V512	V0	V512	V0	V512	V0	V512
V0	V512	V0	V512	V0	V512	V0	V512	V0

1 pixel 1 dot

[Note] Interface to adjust Vcom

- Using Via Hole : 1.5mm Pitch (ϕ 0.7mm)
- Mating connector : (housing)3P-SZN, (contact)SZN-002T-P0.7K (JST Co.,Ltd.)
- Communication method : I2C

Pin No.	symbol	Function	Remark
1	SDA	I2C DATA	Pull up:3.3V[Note1]
2	SCL	I2C CLK	Pull up:3.3V[Note1]
3	GND	GND	-

Refer to specifications of ISL24837 for the I2C command of Vcom adjustment.

[Note1]Interface

[Note2] The equivalent circuit figure of the terminal



4.3. Absolute maximum ratings

Parameter	Symbol	Condition	Ratings	Unit	Remark
Input voltage	V_I	$T_a=25^{\circ}\text{C}$	-0.3 ~ 3.6	V	[Note 1]
12V supply voltage	VCC	$T_a=25^{\circ}\text{C}$	0 ~ +14	V	
Storage temperature	Tstg	-	-25 ~ +60	$^{\circ}\text{C}$	[Note 2]
Operation temperature	Topa	-	0 ~ +50	$^{\circ}\text{C}$	

[Note1] Applies to the input signals to C-PWB
SELLVDS, FRAME

[Note2] Applies to the LK460D3HB29 (OpenCell) and C-PWB, CS-FPC

- Humidity: 95%RH Max.($T_a \leq 40^{\circ}\text{C}$)
- Maximum wet-bulb temperature at 39°C or less. ($T_a > 40^{\circ}\text{C}$)
- No condensation.

4.4. Electrical characteristics of input signals

Ta=25°C

Parameter	Symbol	Min.	Typ.	Max.	Unit	Remark
+12V supply voltage	Supply voltage	Vcc	11.4	12	12.6	V [Note 1]
	Current dissipation	Icc	-	700	2000	mA [Note 2]
	Inrush current	IRUSH1	-	4380	-	mA t1=500µs [Note 7]
Permissible input ripple voltage	VRP	-	-	100	mVp-p	Vcc = +12.0V
Input Low voltage	VIL	0	-	0.7	V	[Note 3]
Input High voltage	VIH	2.3	-	3.3	V	
Input leak current (Low)	IIL1			400	µA	VI = 0V [Note 4]
	IIL2	-	-	40		VI = 0V [Note 5]
Input leak current (High)	IIH1			40	µA	VI = 3.3V [Note 4]
	IIH2	-	-	400		VI = 3.3V [Note 5]
Terminal resistor	RT	-	100	-	Ω	Differential input
Input Differential voltage	VID	200	400	600	mV	[Note6]
Differential input common mode voltage	VCM	VID /2	1.2	2.4- VID /2	V	[Note6]

[Note] VCM: Common mode voltage of LVDS driver.

[Note 1]

Input voltage sequences

- 50µs < t1 ≤ 20ms
- 20 < t2 ≤ 50ms
- 20 < t3 ≤ 50ms
- 0 < t4 ≤ 1s
- 1s ≤ t5
- 0 ≤ t6
- 1s ≤ t7

Dip conditions for supply voltage

- a) 9.1V ≤ Vcc < 10.8V
- td ≤ 10ms
- b) Vcc < 9.1V

This case is based on input voltage sequences.

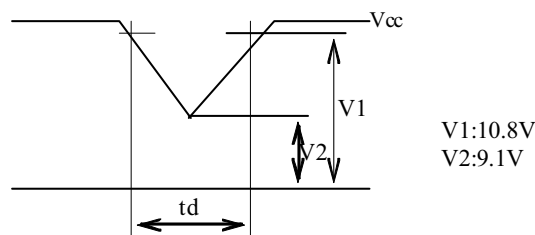
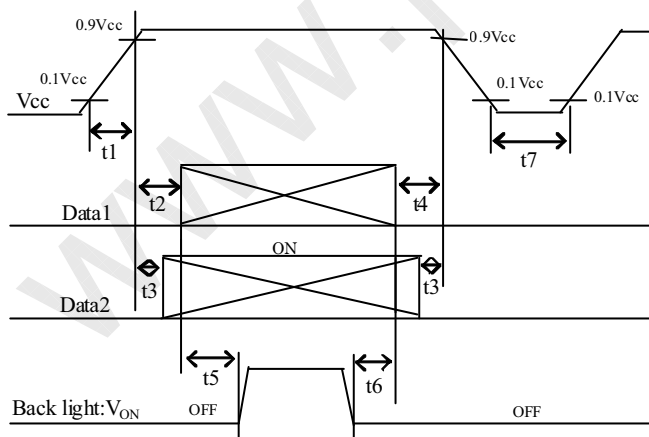

- *Data1: ACK±, AIN0±, AIN1±, AIN2±, AIN3±, AIN4±, BCK±, BIN0±, BIN1±, BIN2±, BIN3±, BIN4±,
- *VCM voltage pursues the sequence mentioned above
- *Data2: SELVDS, FRAME

[Note] About the relation between data input and back light lighting, please base on the above-mentioned input sequence. When back light is switched on before panel operation or after a panel operation

stop, it may not display normally. But this phenomenon is not based on change of an incoming signal, and does not give damage to a liquid crystal display.

[Note 2] Typical current situation: 1024 gray-bar patterns. ($V_{CC} = +12.0V$)

The explanation of RGB gray scale is seen in section 4.8.

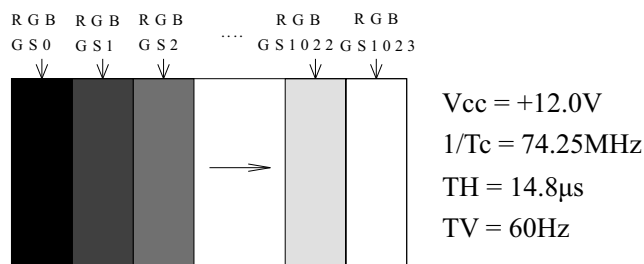

[Note 3] SELLVDS, FRAME

[Note 4] SELLVDS

[Note 5] FRAME

[Note 6] $ACK\pm, AIN0\pm, AIN1\pm, AIN2\pm, AIN3\pm, AIN4\pm, BCK\pm, BIN0\pm, BIN1\pm, BIN2\pm, BIN3\pm, BIN4\pm$

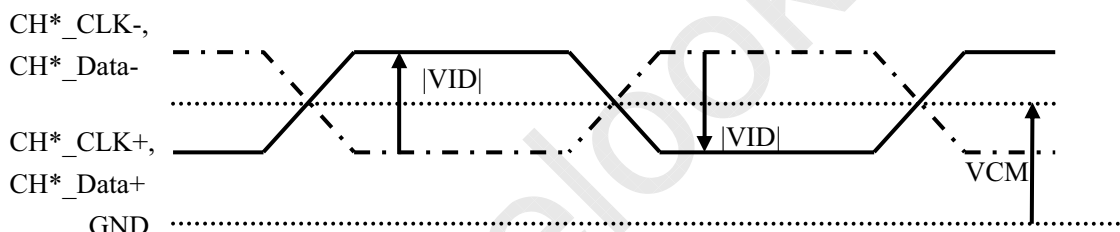

[Note6] $V_{CC}12V$ inrush current waveform

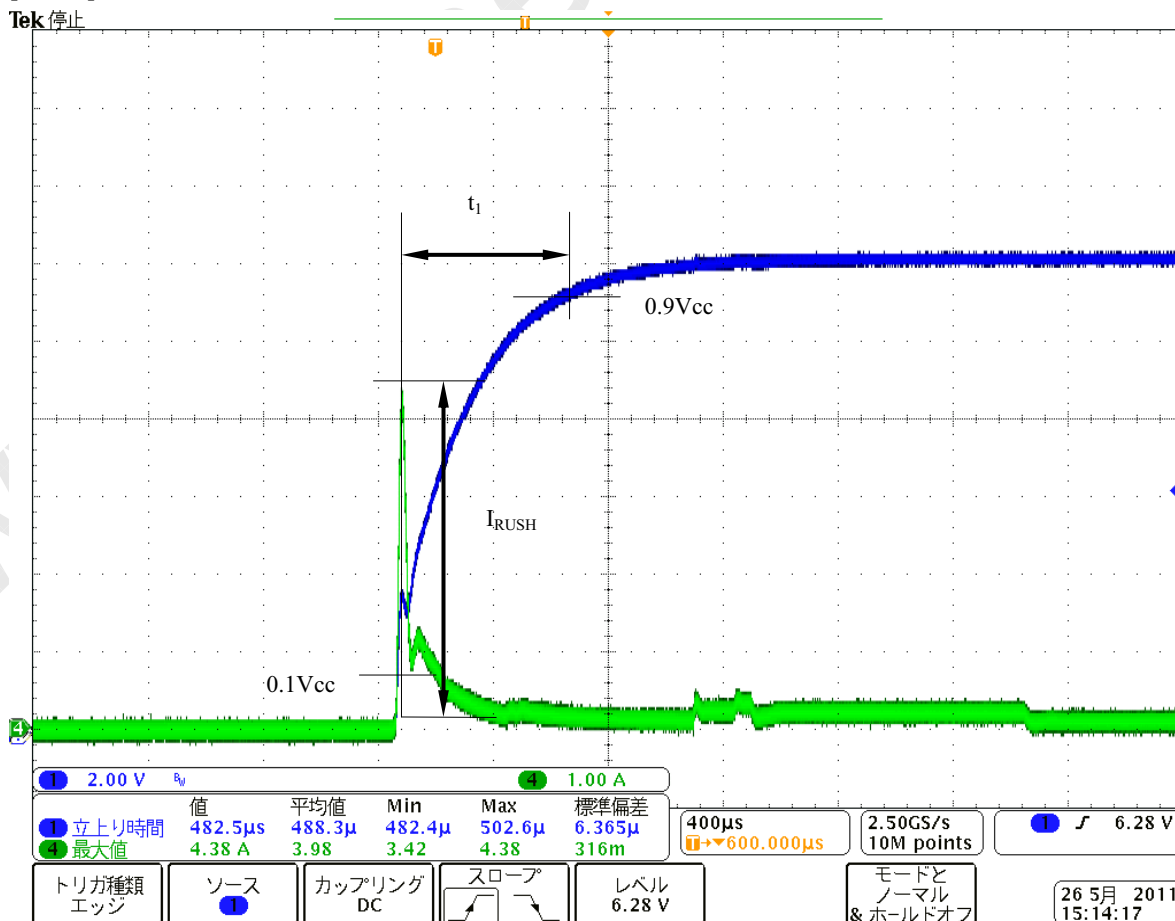

4.5. Timing characteristics of input signals

Timing diagrams of input signal are shown in below figure.

Parameter		Symbol	Min.	Typ.	Max.	Unit	Remark
Clock	Frequency	1/Tc	67	74.25	76	MHz	
Data enable signal	Horizontal period	TH	1050	1100	1300	clock	
			14.2	14.8	16.1	μs	
	Horizontal period (High)	THd	960	960	960	clock	
	Vertical period	TV	1109	1350	1125	line	
			47	50	60	Hz	
Vertical period (High)	TVd	1080	1080	1080	line		

[Note]

- When vertical period is very long, flicker and etc. may occur.
- Please turn off the module after it shows the black screen.
- Please make sure that length of vertical period should become of an integral multiple of horizontal length of period. Otherwise, the screen may not display properly.
- As for your final setting of driving timing, we will conduct operation check test at our side, please inform your final setting.

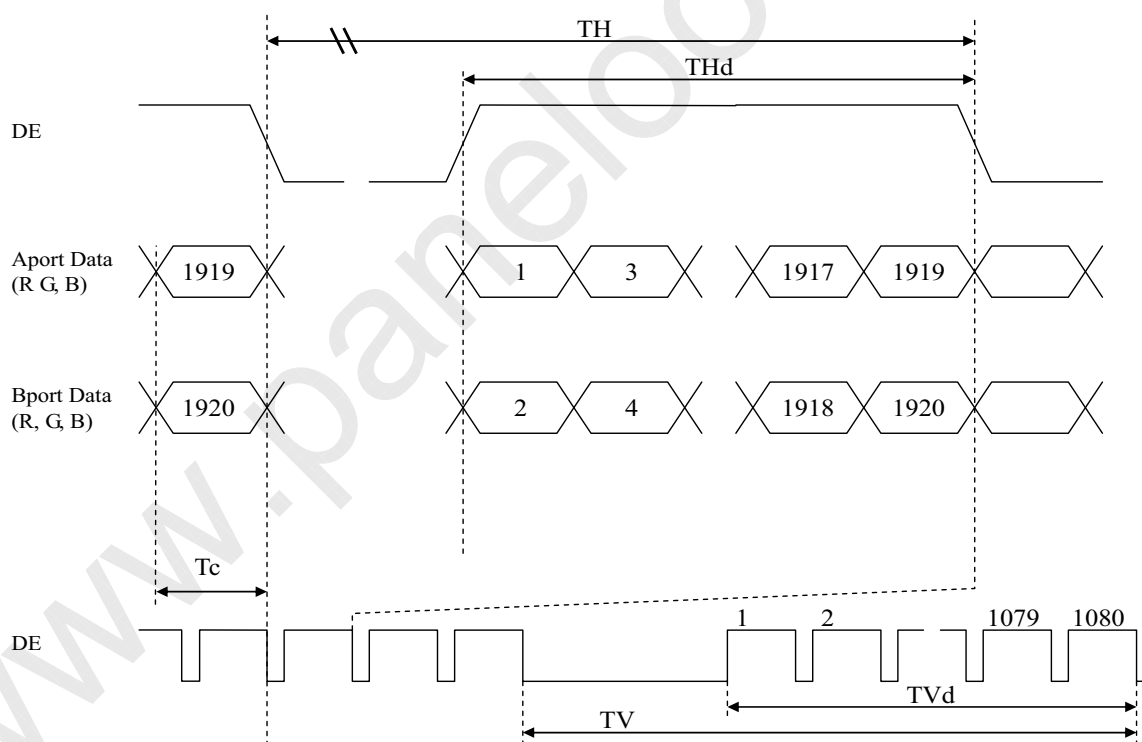

Timing diagram of input signal

4.6. Input data signal and display position on the screen

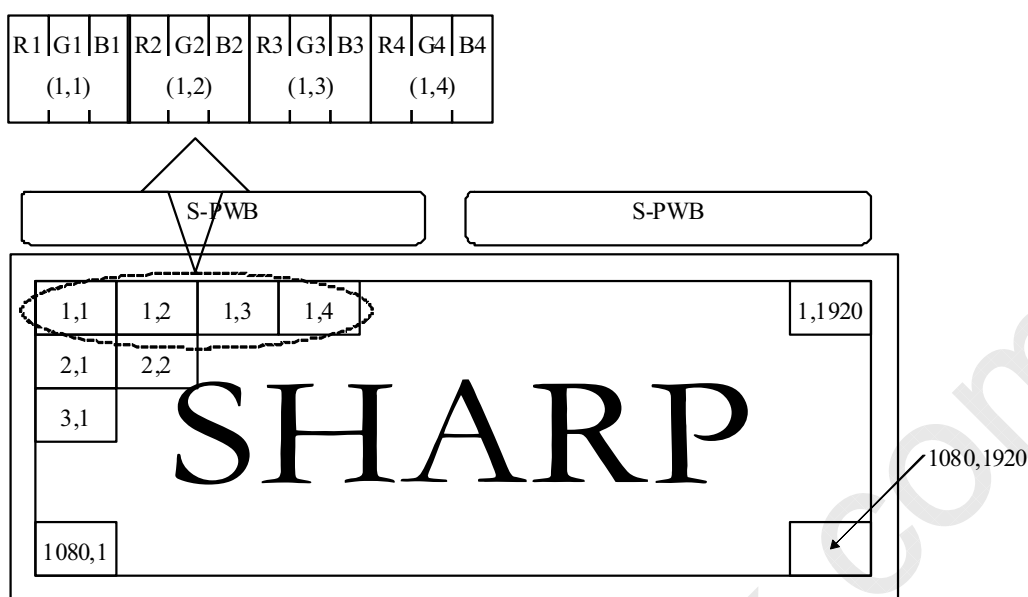

[Note] Scan direction is setting for using S-PWBs' side up.

4.7. LVDS signal characteristics

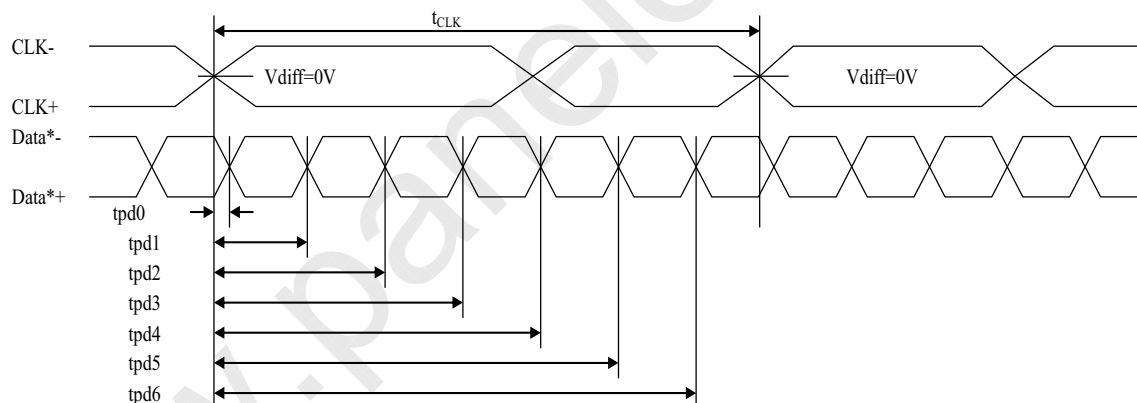

Item	Symbol	Min.	Typ.	Max.	Unit	
LVDS Clock Period	t_{CLK}	13.16	13.47	14.93	ns	
Data position	Delay time, CLK rising edge to serial bit position 0	tpd0	-0.25	0	0.25	ns
	Delay time, CLK rising edge to serial bit position 1	tpd1	$1*t_{CLK}/7-0.25$	$1*t_{CLK}/7$	$1*t_{CLK}/7+0.25$	
	Delay time, CLK rising edge to serial bit position 2	tpd2	$2*t_{CLK}/7-0.25$	$2*t_{CLK}/7$	$2*t_{CLK}/7+0.25$	
	Delay time, CLK rising edge to serial bit position 3	tpd3	$3*t_{CLK}/7-0.25$	$3*t_{CLK}/7$	$3*t_{CLK}/7+0.25$	
	Delay time, CLK rising edge to serial bit position 4	tpd4	$4*t_{CLK}/7-0.25$	$4*t_{CLK}/7$	$4*t_{CLK}/7+0.25$	
	Delay time, CLK rising edge to serial bit position 5	tpd5	$5*t_{CLK}/7-0.25$	$5*t_{CLK}/7$	$5*t_{CLK}/7+0.25$	
	Delay time, CLK rising edge to serial bit position 6	tpd6	$6*t_{CLK}/7-0.25$	$6*t_{CLK}/7$	$6*t_{CLK}/7+0.25$	

4.8. Input signal, basic display colors and gray scale of each color

Colors & Gray Scale			Data signal																										
			R0 R1 R2 R3 R4 R5 R6 R7 R8 R9	G0 G1 G2 G3 G4 G5 G6 G7 G8 G9	B0 B1 B2 B3 B4 B5 B6 B7 B8 B9																								
Basic Color	Black	—	0 0 0 0 0 0 0 0 0 0	0 0 0 0 0 0 0 0 0 0	0 0 0 0 0 0 0 0 0 0																								
	Blue	—	0 0 0 0 0 0 0 0 0 0	0 0 0 0 0 0 0 0 0 0	1 1 1 1 1 1 1 1 1 1																								
	Green	—	0 0 0 0 0 0 0 0 0 0	1 1 1 1 1 1 1 1 1 1	0 0 0 0 0 0 0 0 0 0																								
	Cyan	—	0 0 0 0 0 0 0 0 0 0	1 1 1 1 1 1 1 1 1 1	1 1 1 1 1 1 1 1 1 1																								
	Red	—	1 1 1 1 1 1 1 1 1 1	0 0 0 0 0 0 0 0 0 0	0 0 0 0 0 0 0 0 0 0																								
	Magenta	—	1 1 1 1 1 1 1 1 1 1	0 0 0 0 0 0 0 0 0 0	1 1 1 1 1 1 1 1 1 1																								
	Yellow	—	1 1 1 1 1 1 1 1 1 1	1 1 1 1 1 1 1 1 1 1	0 0 0 0 0 0 0 0 0 0																								
	White	—	1 1 1 1 1 1 1 1 1 1	1 1 1 1 1 1 1 1 1 1	1 1 1 1 1 1 1 1 1 1																								
Gray Scale of Red	Black	GS0	0 0 0 0 0 0 0 0 0 0	0 0 0 0 0 0 0 0 0 0	0 0 0 0 0 0 0 0 0 0																								
	---	GS1	1 0 0 0 0 0 0 0 0 0	0 0 0 0 0 0 0 0 0 0	0 0 0 0 0 0 0 0 0 0																								
	---	GS2	0 1 0 0 0 0 0 0 0 0	0 0 0 0 0 0 0 0 0 0	0 0 0 0 0 0 0 0 0 0																								
	---	---																											
	---	---																											
	---	GS1021	1 0 1 1 1 1 1 1 1 1	0 0 0 0 0 0 0 0 0 0	0 0 0 0 0 0 0 0 0 0																								
	---	GS1022	0 1 1 1 1 1 1 1 1 1	0 0 0 0 0 0 0 0 0 0	0 0 0 0 0 0 0 0 0 0																								
	Red	GS1023	1 1 1 1 1 1 1 1 1 1	0 0 0 0 0 0 0 0 0 0	0 0 0 0 0 0 0 0 0 0																								
Gray Scale of Green	Black	GS0	0 0 0 0 0 0 0 0 0 0	0 0 0 0 0 0 0 0 0 0	0 0 0 0 0 0 0 0 0 0																								
	---	GS1	0 0 0 0 0 0 0 0 0 0	1 0 0 0 0 0 0 0 0 0	0 0 0 0 0 0 0 0 0 0																								
	---	GS2	0 0 0 0 0 0 0 0 0 0	0 1 0 0 0 0 0 0 0 0	0 0 0 0 0 0 0 0 0 0																								
	---	---																											
	---	---																											
	---	GS1021	0 0 0 0 0 0 0 0 0 0	1 0 1 1 1 1 1 1 1 1	0 0 0 0 0 0 0 0 0 0																								
	---	GS1022	0 0 0 0 0 0 0 0 0 0	0 1 1 1 1 1 1 1 1 1	0 0 0 0 0 0 0 0 0 0																								
	Green	GS1023	0 0 0 0 0 0 0 0 0 0	1 1 1 1 1 1 1 1 1 1	0 0 0 0 0 0 0 0 0 0																								
Gray Scale of Blue	Black	GS0	0 0 0 0 0 0 0 0 0 0	0 0 0 0 0 0 0 0 0 0	0 0 0 0 0 0 0 0 0 0																								
	---	GS1	0 0 0 0 0 0 0 0 0 0	0 0 0 0 0 0 0 0 0 0	1 0 0 0 0 0 0 0 0 0																								
	---	GS2	0 0 0 0 0 0 0 0 0 0	0 0 0 0 0 0 0 0 0 0	0 1 0 0 0 0 0 0 0 0																								
	---	---																											
	---	---																											
	---	GS1021	0 0 0 0 0 0 0 0 0 0	0 0 0 0 0 0 0 0 0 0	1 0 1 1 1 1 1 1 1 1																								
	---	GS1022	0 0 0 0 0 0 0 0 0 0	0 0 0 0 0 0 0 0 0 0	0 1 1 1 1 1 1 1 1 1																								
	Blue	GS1023	0 0 0 0 0 0 0 0 0 0	0 0 0 0 0 0 0 0 0 0	1 1 1 1 1 1 1 1 1 1																								

- 0: Low level voltage / 1: High level voltage

- Each basic color can be displayed in 1021 gray scales from 10 bits data signals. According to the combination of total 30 bits data signals, one billion-color display can be achieved on the screen.

5. Optical characteristics

Ta=25°C, Vcc=12.0V, LED current = ±120mA, Timing: 60Hz (typ. value)

Parameter	Symbol	Condition	Min.	Typ.	Max.	Unit	Remark	
Viewing angle range	Horizontal	θ_{21} θ_{22}	CR \geq 10	80	88	-	Deg.	[Note1,4]
	Vertical	θ_{11} θ_{12}		80	88	-	Deg.	
Contrast ratio	CRn	$\theta=0$ deg.	-	4000	-	-	[Note2,4]	
Response time	τ_{DRV}		-	6	-	ms	[Note3,4,5]	
Chromaticity	White		x	0.256	0.286	0.316	-	[Note4]
			y	0.257	0.287	0.317	-	
	Red		x	0.628	0.658	0.688	-	
			y	0.304	0.334	0.364	-	
	Green		x	0.277	0.307	0.337	-	
			y	0.568	0.598	0.628	-	
	Blue		x	0.119	0.149	0.179	-	
			y	0.035	0.065	0.095	-	
Luminance	White	Y_L	-	500	-	cd/m ²		
Luminance uniformity	White	δ_w	-	-	1.25	-	[Note6]	

- Optical characteristics are based on SHARP standard module.
- The measurement shall be executed 60 minutes after lighting at rating.

[Note] The optical characteristics are measured using the following equipment.

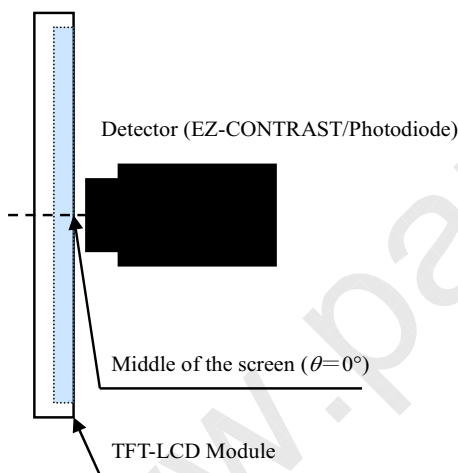

Measurement of viewing angle range and Response time.

- Viewing angle range: EZ-CONTRAST
- Response time: Photodiode

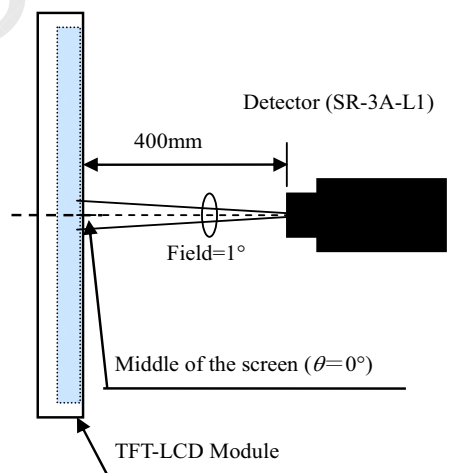

Measurement of Contrast, Luminance, Chromaticity.

[Note1] Definitions of viewing angle range:

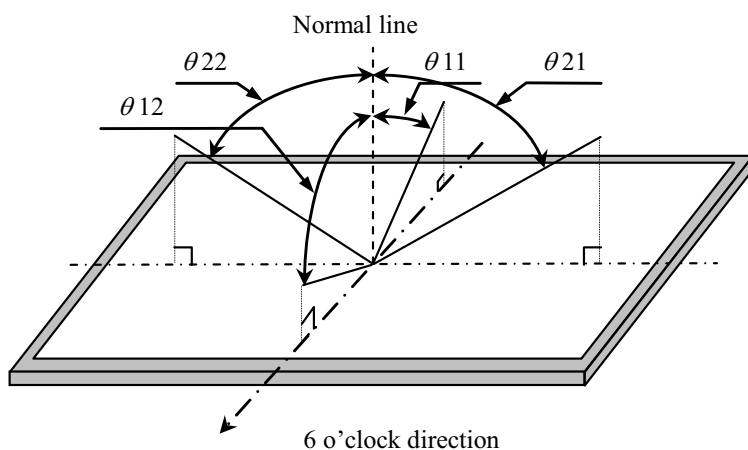

[Note2] Definition of contrast ratio:

The contrast ratio is defined as the following.

$$\text{Contrast Ratio} = \frac{\text{Luminance (brightness) with all pixels white}}{\text{Luminance (brightness) with all pixels black}}$$

[Note3] Definition of response time

The response time (τ) is defined as the following figure and shall be measured by switching the input signal for “any level of gray (0%, 25%, 50%, 75% and 100%)” and “any level of gray (0%, 25%, 50%, 75% and 100%)”.

	0%	25%	50%	75%	100%
0%		tr: 0%-25%	tr: 0%-50%	tr: 0%-75%	tr: 0%-100%
25%	td: 25%-0%		tr: 25%-50%	tr: 25%-75%	tr: 25%-100%
50%	td: 50%-0%	td: 50%-25%		tr: 50%-75%	tr: 50%-100%
75%	td: 75%-0%	td: 75%-25%	td: 75%-50%		tr: 75%-100%
100%	td: 100%-0%	td: 100%-25%	td: 100%-50%	td: 100%-75%	

t*:x-y --- response time from level of gray(x) to level of gray(y)

$$\tau_{DRV} = \sum (t^* : x - y) / 20$$

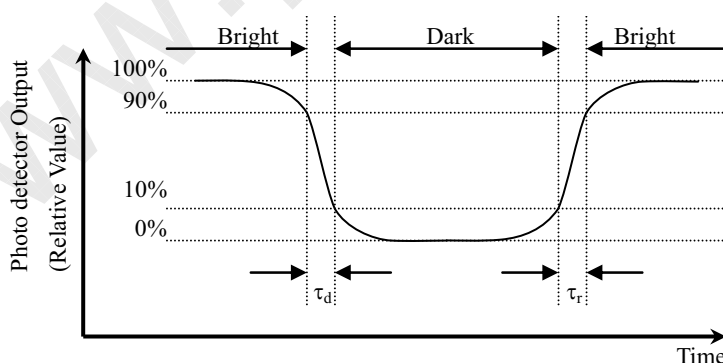

[Note4] This value shall be measured at center of the screen.

[Note5] This value is valid when O/S driving is used at typical input time value.

[Note6] This value is calculated as the following with nine measurements. (A~E)

$$\delta_w = \frac{\text{Maximum luminance of five points (brightness)}}{\text{Minimum luminance of five points (brightness)}}$$

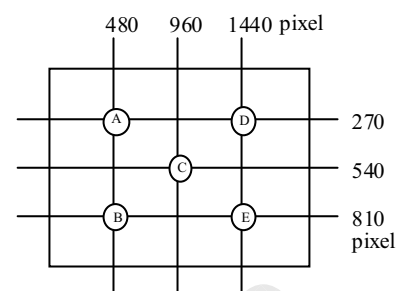

6. Packing for shipping

6.1. Packing form

- a) Open Cell quantity in 1 cell box : 10 cells
- b) Piling number of cell box : 10 Maximum
- c) 1 pallet size : 1568 (W) x 1272 (D) x 715 (H) [mm]
- d) Total mass of 1 pallet filled with full open cells : 328 kg Maximum

6.2. Label

a) Open Cell Label

This label is stuck on the protection film of front polarizer.

ex) LK460D3HB29

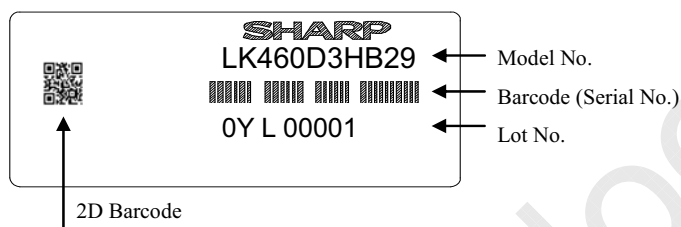

How to express Lot No.

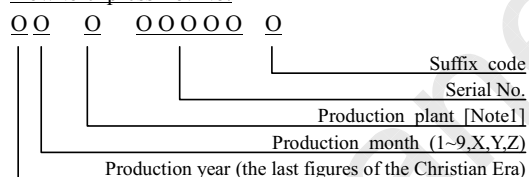

[Note1] Production plant code

Code	Plant	Model No. & Suffix Code
L,K,Z	Japan	LK460D3HB29

b) Packing label

This label is stuck on the cell box and palette.

ex) LK460D3HB29

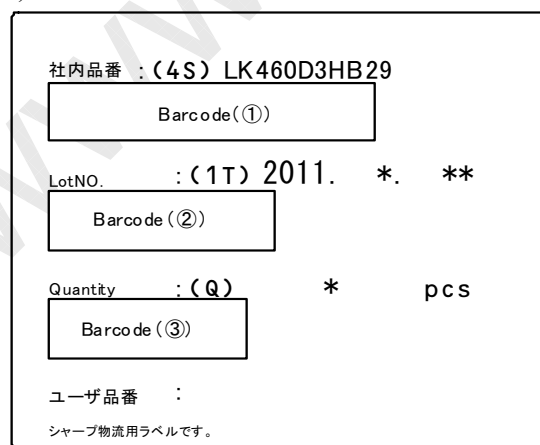

- ① Model No.& Suffix Code
- ② Lot No.
- ③ Quantity

7. Reliability test item

No.	Test item	Condition
1	High temperature storage test (Open Cell)	Ta = 60°C 240h
2	Low temperature storage test (Open Cell)	Ta = -25°C 240h
3	High temperature and high humidity operation test (Open Cell)	Ta = 40°C 95%RH 240h (No condensation)
4	High temperature operation test (Open Cell)	Ta = 50°C 240h
5	Low temperature operation test (Open Cell)	Ta = 0°C 240h
6	Vibration test (Cell Box with full Open Cells)	X and Y direction: 15min, Z direction: 60min. 5Hz to 50Hz acceleration velocity: 1.0G Sweeping ratio: 3min
7	Drop test (Cell Box with full Open Cells)	Height: 25cm (corner and edge), 32cm (surface) Number: 8times (corner 1time and edge 3times and surface 4times)

[Result evaluation criteria]

Under the display quality test condition with normal operation state, there shall be no change, which may affect practical display function.

8. Precautions

- Be sure to turn off the power supply when inserting or disconnecting the cable.
- Be sure to design the module and cabinet so that the Open Cell can be installed without any extra stress such as warp or twist.
- Since the polarizer is easily damaged, pay attention not to scratch it.
- Since long contact with water may cause discoloration or spots, wipe off water drop immediately.
- When the polarizer is soiled, wipe it with absorbent cotton or other soft cloth.
- Since the panel is made of glass, it may break or crack if dropped or bumped on hard surface. Handle with care.
- Precautions of peeling off the protection film.

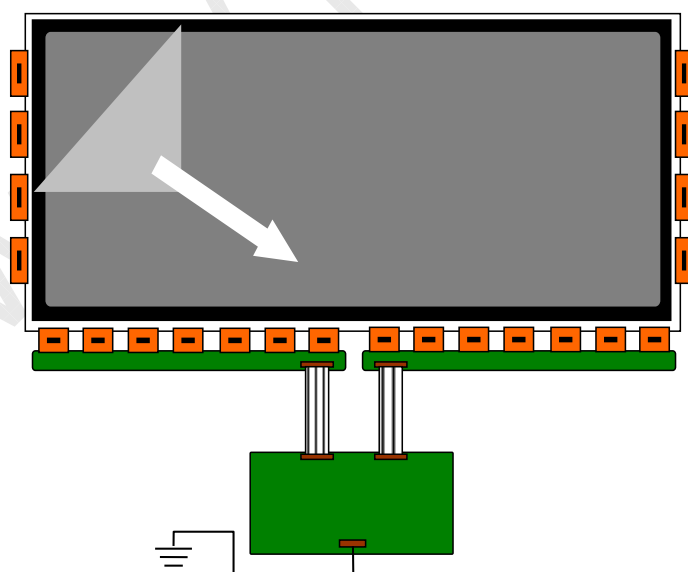

- Be sure to peel off slowly (recommended more than 7sec) and constant speed.
- Peeling direction shows Fig.
- Be sure to ground person with adequate methods such as the anti-static wrist band.
- Be sure to ground S-PWB while peeling of the protection film.
- Ionized air should be blown over during peeling action.
- The protection film must not touch drivers and S-PWBs.
- If adhesive may remain on the polarizer after the protection film peeling off, please remove with isopropyl-alcohol.

- Since the Open Cell consists of TFT and electronic circuits with CMOS-ICs, which are very weak to

electrostatic discharges, persons who are handling the Open Cell should be grounded through adequate methods such as the anti-static wrist band. Connector pins should not be touched directly with bare hands.

- Reference : Process control standard of sharp

	Item	Management standard value and performance standard
1	Anti-static mat (shelf)	1 to 50 [M ohm]
2	Anti-static mat (floor, desk)	1 to 100 [M ohm]
3	Ionizer	Attenuate from $\pm 1000V$ to $\pm 100V$ within 2 sec
4	Anti-static wrist band	0.8 to 10 [M ohm]
5	Anti-static wrist band entry and ground resistance	Below 1000 [ohm]
6	Temperature	22 to 26 [$^{\circ}C$]
7	Humidity	60 to 70 [%RH]

- i) The Open Cell has some PWBs, take care to keep them from any stress or pressure when handling or installing the Open Cell, otherwise some of electronic parts on the PWBs may be damaged.
- j) When handling the Open Cell and assembling them into module and cabinets, please be noted that long-term storage in the environment of oxidization or deoxidization gas and the use of such materials as reagent, solvent, adhesive, resin, etc. which generate these gasses, may cause corrosion and discoloration of the Open Cell.
- k) Applying too much force and stress to PWB and driver (COF) may cause a malfunction electrically and mechanically.
- l) The Open Cell has high frequency circuits. Sufficient suppression to EMI should be done by system manufacturers.
- m) Please be careful since image retention may occur when a fixed pattern is displayed for a long time.
- n) The chemical compound, which causes the destruction of ozone layer, is not used.
- o) This Open Cell is corresponded to RoHS.
- p) When any question or issue occurs, it shall be solved by mutual discussion.

9. Carton storage condition

Temperature	0 $^{\circ}C$ to 40 $^{\circ}C$
Humidity	95% RH or less
Reference condition	20 $^{\circ}C$ to 35 $^{\circ}C$, 85% RH or less (summer) 5 $^{\circ}C$ to 15 $^{\circ}C$, 85% RH or less (winter) the total storage time (40 $^{\circ}C$, 95% RH) : 240h or less
Sunlight	Be sure to shelter a production from the direct sunlight.
Atmosphere	Harmful gas, such as acid and alkali which bites electronic components and/or wires must not be detected.
Notes	Be sure to put cartons on palette or base, don't put it on floor, and store them with removing from wall. Please take care of ventilation in storehouse and around cartons, and control changing temperature is within limits of natural environment.
Storage life	6 months

10. Caring for the Liquid Crystal panel

General instructions of "Caring for the Liquid Crystal panel" to our customer are as follows;

1. Gently wipe the surface of the display panel with a soft cloth (cotton, flannel, etc.).
Wiping with a hard cloth or using strong force may scratch the surface of the display panel.
2. Use a soft damp cloth to gently wipe the display panel when it is really dirty.
(It may scratch the surface of the display panel when wiped strongly.)
3. If the display panel is dusty, use an anti-static brush, which is commercially available, to clean it.
4. To protect the display panel, do not use a dirty cloth, liquid cleaners, or a chemical cloth (wet/dry sheet type cloth, etc.).

This may damage the surface of the display panel.

*Note

Recommended treatment for the surface of Polarizer

1. Do not touch the surface of the Polarizer.
When transporting or working on the display, handle with care not to touch the Polarizer.
2. Use an anti-static brush, if the surface of the Polarizer is dusty.
Take care of damages and stains of the brush.
3. Do not stack the display modules.
4. Clean with following steps, if stains are on the surface.
 - a) Wipe with an approved clean cloth.
 - b) Breathe on the stain and wipe.
 - c) Wipe with a clean cloth damped with minimum quantity of IPA diluted with water.

"Caution"

:Do not use too much solvent.

It may causes spots, and the risk of scratches will increase to clean the spots.

:Take care of damages and stains of a cloth.

A change of cloths must be required regularly.

Old cloths may scratch the Polarizer.

:Make sure that the treatment is appropriate, first.

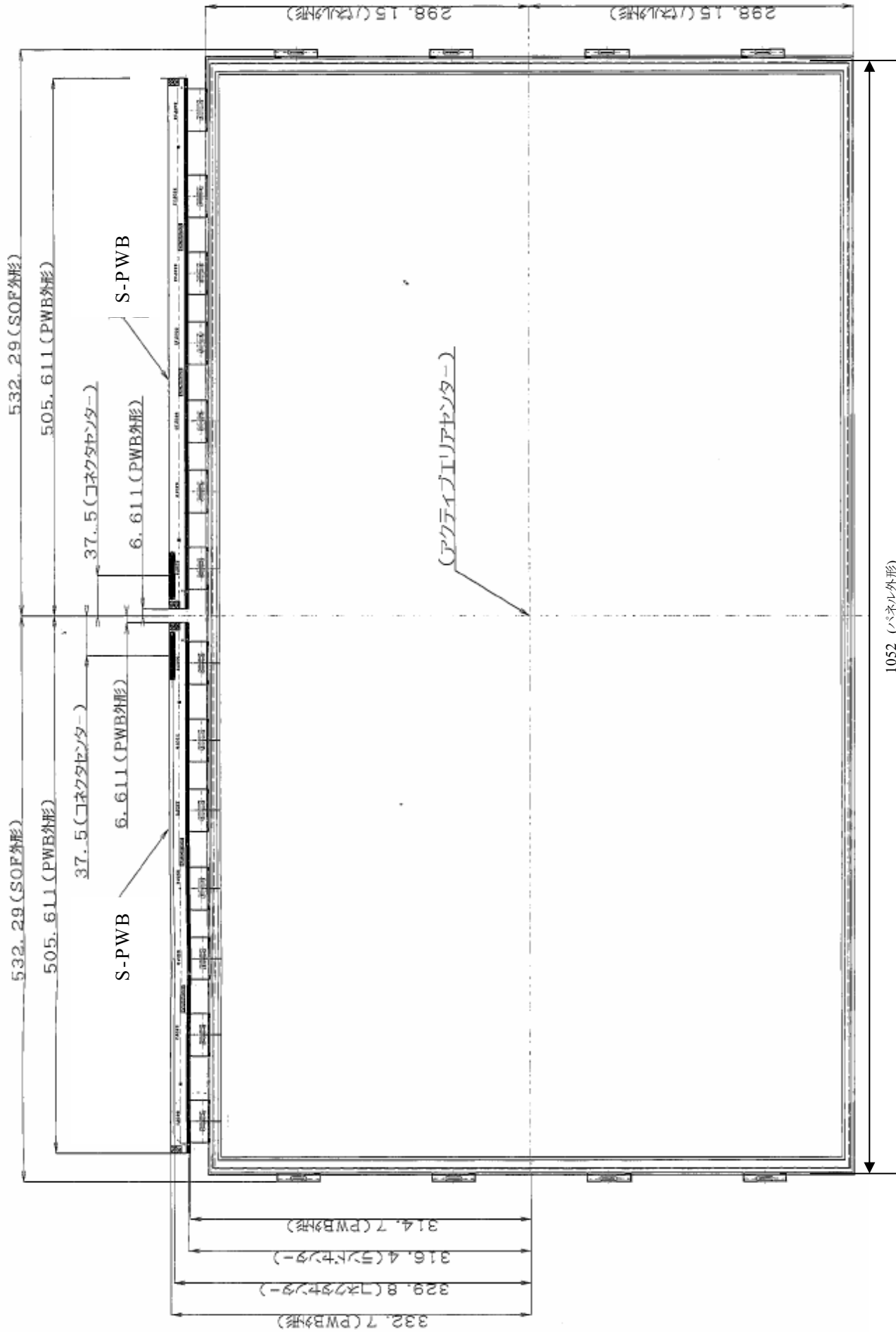

LK460D3HB29

