

PRODUCT SPECIFICATIONS

SHARP

AVC Liquid Crystal Displays Group

LK520D1LH00

TFT-LCD Module

Spec. Issue Date: June 30, 2007

No: LD-20125-1

1. Application

This specification applies to the color 52.0" TFT-LCD module LK520D1LH00.

* These technical literature are proprietary products of SHARP CORPORATION ("SHARP") and include materials protected under copyright of SHARP. Do not reproduce or cause any third party to reproduce them in any form or by any means, electronic or mechanical, for any purpose, in whole or in part, without the express written permission of SHARP.

* In case of using the device for applications such as control and safety equipment for transportation (aircraft, trains, automobiles, etc.), rescue and security equipment and various safety related equipment which require higher reliability and safety, take into consideration that appropriate measures such as fail-safe functions and redundant system design should be taken.

* Do not use the device for equipment that requires an extreme level of reliability, such as aerospace applications, telecommunication equipment (trunk lines), nuclear power control equipment and medical or other equipment for life support.

* SHARP assumes no responsibility for any damage resulting from the use of the device that does not comply with the instructions and the precautions specified in these specification.

* Contact and consult with a SHARP sales representative for any questions about this device.

2. Overview

This module is a color active matrix LCD module incorporating amorphous silicon TFT (Thin Film Transistor). It is composed of a color TFT-LCD panel, driver ICs, control circuit, power supply circuit, inverter circuit and back light system etc. Graphics and texts can be displayed on a 1920×RGB×1080 dots panel with one billion colors by using LVDS (Low Voltage Differential Signaling) to interface, +12V of DC supply voltages.

This module not includes the DC/AC inverter to drive the CCFT.

And in order to improve the response time of LCD, this module applies the Over Shoot driving (O/S driving) technology for the control circuit. In the O/S driving technology, signals are being applied to the Liquid Crystal according to a pre-fixed process as an image signal of the present frame when a difference is found between image signal of the previous frame and that of the current frame after comparing them.

With this technology, image signals can be set so that liquid crystal response completes within one frame. As a result, motion blur reduces and clearer display performance can be realized.

3. Mechanical Specifications

Parameter	Specifications	Unit
Display size	132.174 (Diagonal)	cm
	52.0 (Diagonal)	inch
Active area	1152.0(H) x 648.0 (V)	mm
Pixel Format	1920(H) x 1080(V) (1pixel = R + G + B dot)	pixel
Pixel pitch	0.600(H) x 0.600 (V)	mm
Pixel configuration	R, G, B vertical stripe	
Display mode	Normally black	
Unit Outline Dimensions (*1)	1219.0(W) x 706.7(H) x 64.6(D)	mm
Mass	21.0 ±1.0	kg
Surface treatment	Anti glare Hard coating: 2H	

(*1) Outline dimensions are shown in Fig.1 (excluding protruding portion)

4. Input Terminals

4.1. TFT panel driving

CN1 (Interface signals and +12V DC power supply) (Shown in Fig.1)

Using connector : FI-RE51S-HF (Japan Aviation Electronics Ind. , Ltd.)

Mating connector : FI-RE51HL, FI-RE51CL (Japan Aviation Electronics Ind. , Ltd.)

Mating LVDS transmitter : THC63LVDM83R or equivalent device

Pin No.	Symbol	Function	Remark
1	GND		
2	Reserved	It is required to set non-connection(OPEN)	Pull up 3.3V
3	Reserved	It is required to set non-connection(OPEN)	Pull up 3.3V
4	Reserved	It is required to set non-connection(OPEN)	Pull up 3.3V
5	Reserved	It is required to set non-connection(OPEN)	Pull down : (GND)
6	Reserved	It is required to set non-connection(OPEN)	Pull down : (GND)
7	SELLVDS	Select LVDS data order [Note1,2]	Pull down : (GND)
8	Reserved	It is required to set non-connection(OPEN)	Pull down : (GND)
9	O/S set	O/S operation setting H:O/S_ON, L:O/S_OFF [Note 3]	Pull up 3.3V
10	FRAME	Frame frequency setting 1:60Hz 0:50Hz	Pull down :GND
11	GND		
12	AIN0-	Aport (-)LVDS CH0 differential data input	
13	AIN0+	Aport (+)LVDS CH0 differential data input	
14	AIN1-	Aport (-)LVDS CH1 differential data input	
15	AIN1+	Aport (+)LVDS CH1 differential data input	
16	AIN2-	Aport (-)LVDS CH2 differential data input	
17	AIN2+	Aport (+)LVDS CH2 differential data input	
18	GND		
19	ACK-	Aport LVDS Clock signal(-)	
20	ACK+	Aport LVDS Clock signal(+)	
21	GND		
22	AIN3-	Aport (-)LVDS CH3 differential data input	
23	AIN3+	Aport (+)LVDS CH3 differential data input	
24	AIN4-	Aport (-)LVDS CH4 differential data input	
25	AIN4+	Aport (+)LVDS CH4 differential data input	
26	GND		
27	GND		
28	BIN0-	Bport (-)LVDS CH0 differential data input	
29	BIN0+	Bport (+)LVDS CH0 differential data input	
30	BIN1-	Bport (-)LVDS CH1 differential data input	
31	BIN1+	Bport (+)LVDS CH1 differential data input	
32	BIN2-	Bport (-)LVDS CH2 differential data input	
33	BIN2+	Bport (+)LVDS CH2 differential data input	
34	GND		
35	BCK-	Bport LVDS Clock signal(-)	
36	BCK+	Bport LVDS Clock signal(+)	
37	GND		
38	BIN3-	Bport (-)LVDS CH3 differential data input	
39	BIN3+	Bport (+)LVDS CH3 differential data input	
40	BIN4-	Bport (-)LVDS CH4 differential data input	
41	BIN4+	Bport (+)LVDS CH4 differential data input	
42	GND		
43	GND		
44	GND		

45	GND		
46	GND		
47	VCC	+12V Power Supply	
48	VCC	+12V Power Supply	
49	VCC	+12V Power Supply	
50	VCC	+12V Power Supply	
51	VCC	+12V Power Supply	

[note]GND of a liquid crystal panel drive part has connected with a module chassis.

[Note 1]The equivalent circuit figure of the terminal

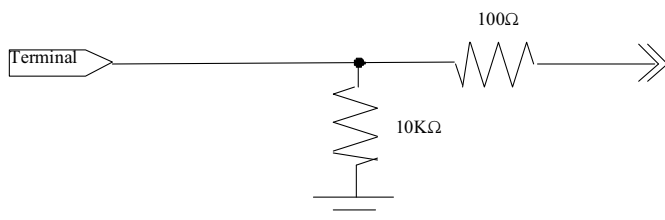

[Note 2] LVDS Data order

SELLVDS		
Data	L(GND) or Open	H(3.3V)
TA0	R2	R4
TA1	R3	R5
TA2	R4	R6
TA3	R5	R7
TA4	R6	R8
TA5	R7	R9(MSB)
TA6	G2	G4
TB0	G3	G5
TB1	G4	G6
TB2	G5	G7
TB3	G6	G8
TB4	G7	G9(MSB)
TB5	B2	B4
TB6	B3	B5
TC0	B4	B6
TC1	B5	B7
TC2	B6	B8
TC3	B7	B9(MSB)
TC4 NA		NA
TC5 NA		NA
TC6	DE(*)	DE(*)
TD0	R8	R2
TD1	R9(MSB)	R3
TD2	G8	G2
TD3	G9(MSB)	G3
TD4	B8	B2
TD5	B9(MSB)	B3
TD6	NA	N/A
TE0	R0(LSB)	R0(LSB)
TE1	R1	R1
TE2	G0(LSB)	G0(LSB)
TE3	G1	G1
TE4	B0(LSB)	B0(LSB)
TE5	B1	B1
TE6	NA	N/A

NA: Not Available

(*)Since the display position is prescribed by the rise of DE(Display Enable)signal, please do not fix DE signal during operation at "High".

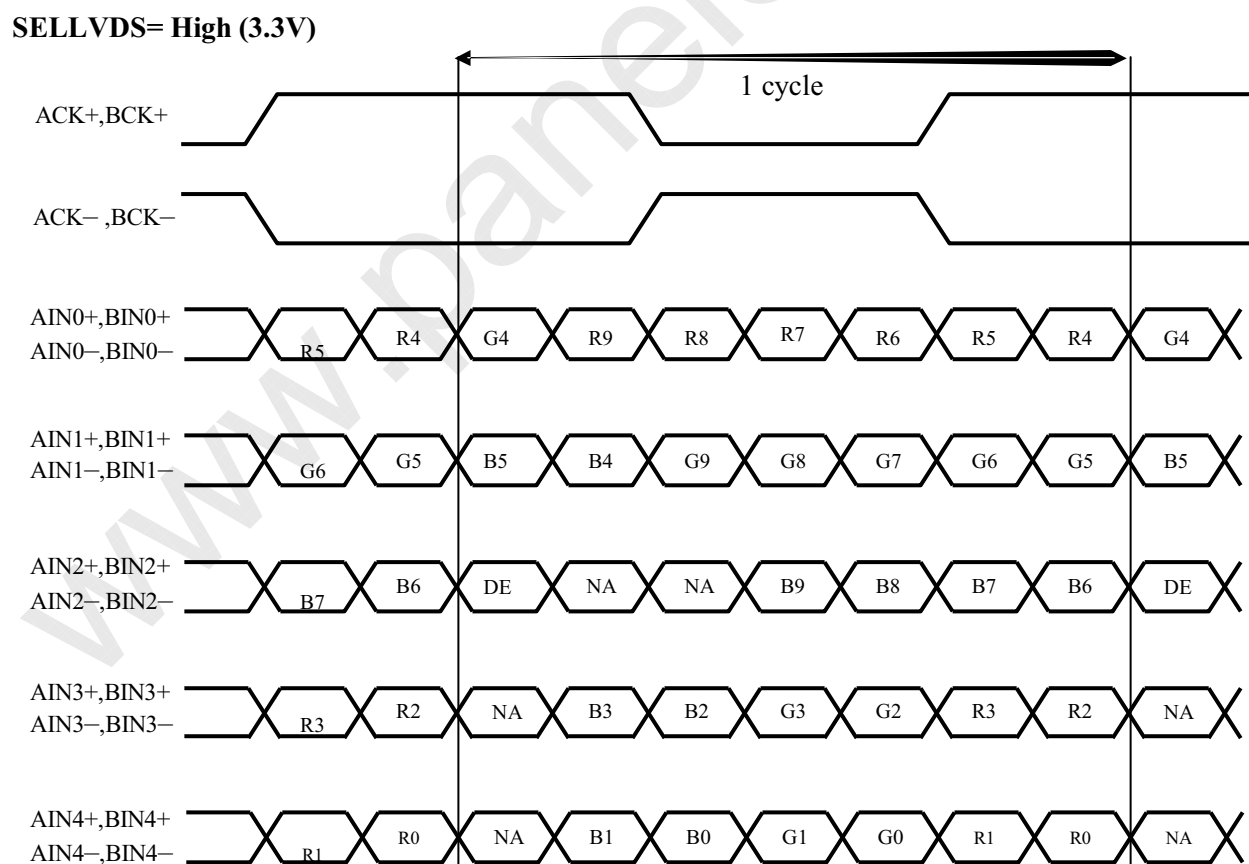
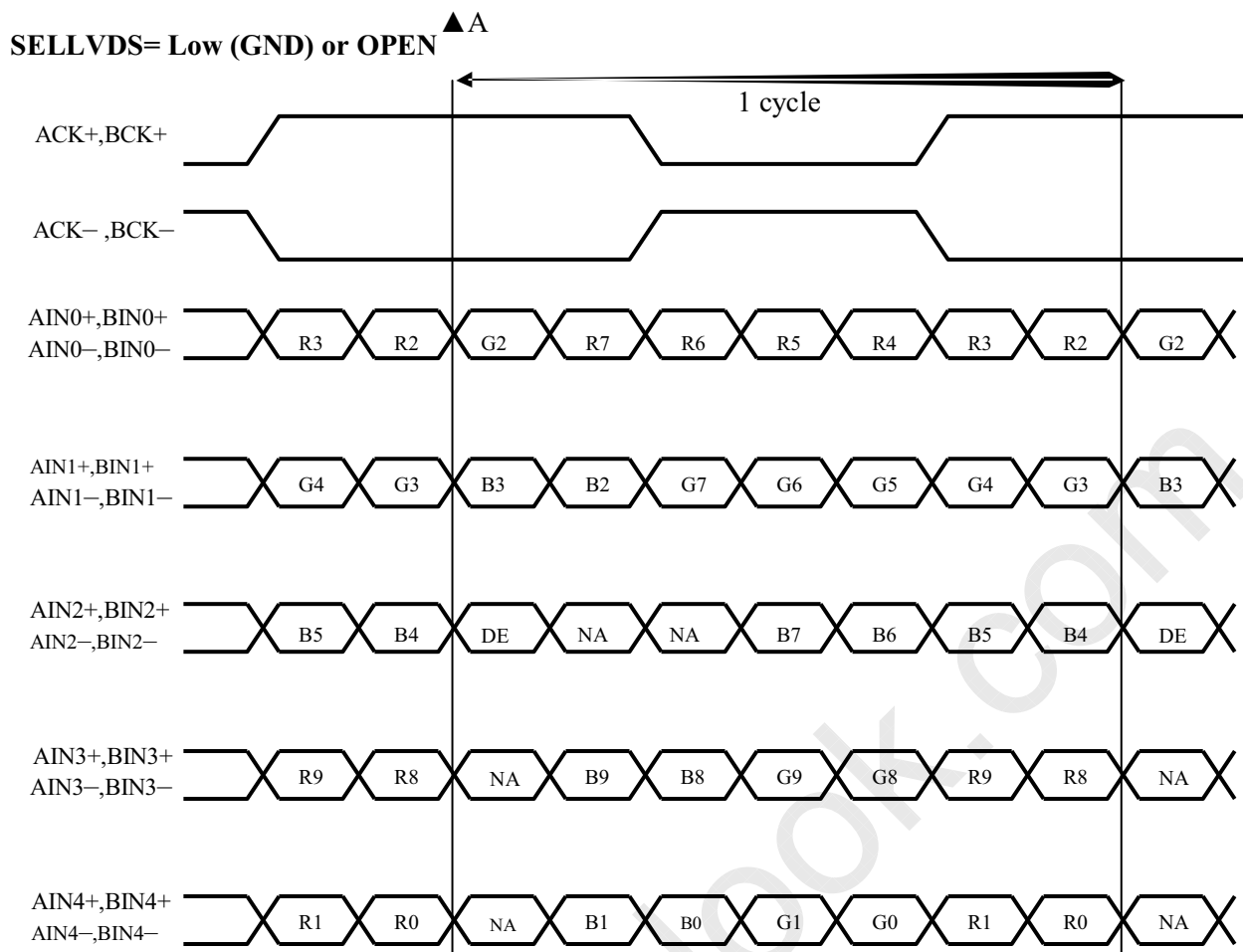

DE: Display Enable, NA: Not Available (Fixed Low)

[Note 3] The equivalent circuit figure of the terminal

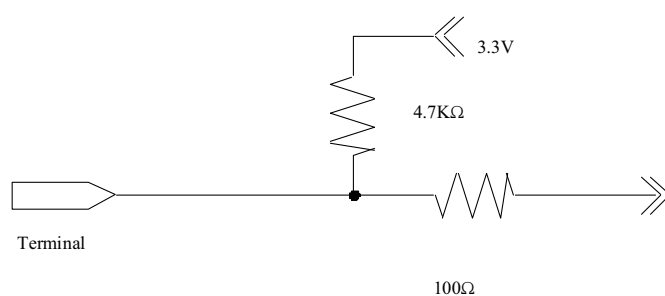

4.2. Interface block diagram

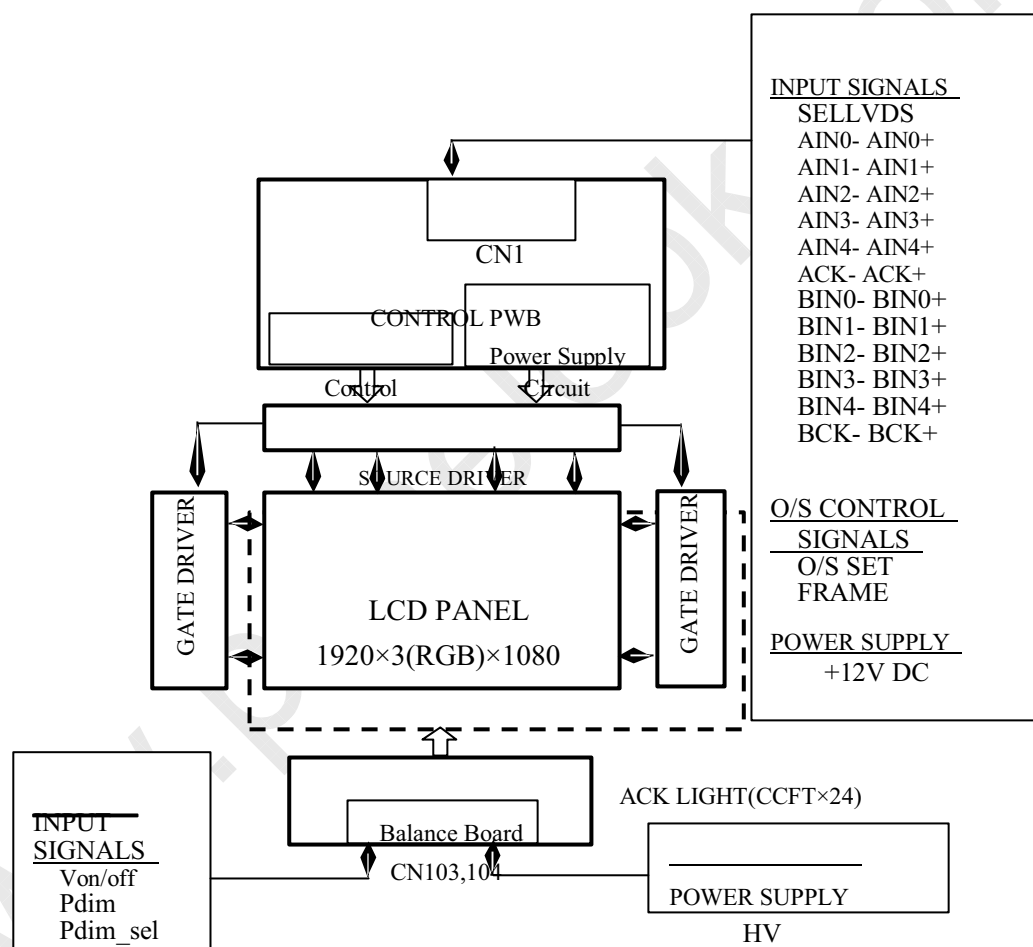

5. Measurement

To test Inverter need to warm up 30 minutes in the beginning, for lamp stability.

5.1 Block diagram

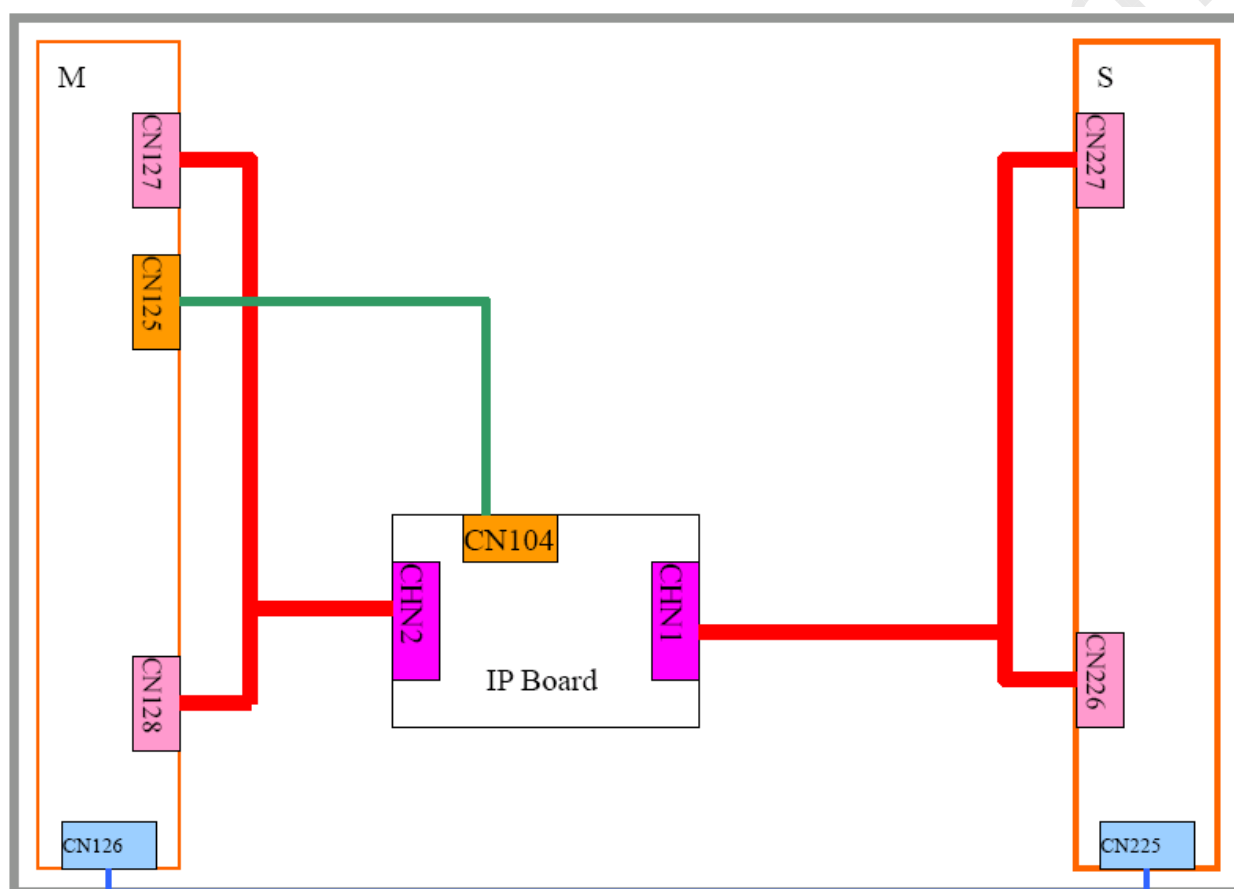

5.2 Test instrument

Item	Function	Instrument Type
1	A • DC CURRENT METER	FLUKE45 or equivalent
2	A • RMS CURRENT METER	2016(YOKOGAWA) or FLUKE45 or P6022 AC Current Probe(Tektronix) or equivalent
3	V • DIGITAL MULTI-METER	FLUKE45 or equivalent
4	V • RMS VOLTAGE METER	TDS 360 (Tektronix) or equivalent , PROBE 1137A(HP) or equivalent
5	F • FERQUENCY COUNTER	5316A(HP) or equivalent
6	O • OSCILLOSCOPE	TDS 3012B (Tektronix)

5.1 Interface connectors on the inverter

□.1High voltage connector:

(CHN1~CHN2 and CN127~CN128 and CN226~CN227): JST_SM02B-BDAS-3-TB-2PIN or equivalent

(CHN101~CHN112 and CN113~CN124):Cvilux CP042CP1MC0

Connector	PIN	SYMBOL	Description	I/O
CHN1	1	HV+	High Voltage	Output
	2	HV-	High Voltage	Output
CHN2	1	HV+	High Voltage	Output
	2	HV-	High Voltage	Output
CN104	1	HV-	High Voltage	Input
CN101	2	HV+	High Voltage	Input
CN203	1	HV-	High Voltage	Input
CN201	2	HV+	High Voltage	Input
CHN101~CHN112	1	HV+	High Voltage	Output
	2	HV-	High Voltage	Output
CN113~CN124	1	HV+	High Voltage	Output
	2	HV-	High Voltage	Output

5.2 Feedback connector:

(CN114) : E&T_7151-E05N-00-R or equivalent

CN114 Pin NO	Name	Description
1	FB	
2	FB	
3	NC	
4	GND	
5	GND	
6	LD	Lamp detected
7	VCC	Supply voltage

5.3. The back light system characteristics

The back light system is direct type with 24 CCFTs (Cold Cathode Fluorescent Tube).

The characteristics of the lamp are shown in the following table. The value mentioned below is at the case of one CCFT.

Item	Symbol	Min.	Typ.	Max.	Unit	Remarks
Life time	T _L	-	60000	-	Hour	[Note]

[Note]

- Lamp life time is defined as the time when brightness becomes 50% of the original value in the continuous operation under the condition of Ta=25°C and brightness control=100%.
- Above value is applicable when the long side of LCD module is placed horizontally (Landscape position). (Lamp lifetime may vary if LCD module is in portrait position due to the change of mercury density inside the lamp.)

6. Electrical Characteristics

6.1. Control circuit driving

		Ta=25°C					
	Parameter	Symbol	Min.	Typ.	Max.	Unit	Remark
+12V supply voltage	Supply voltage	V _{CC}	11.4	12	12.6	V	[Note 1]
	Current dissipation	I _{CC}	-	0.8	2.0	A	[Note 2]
		I _{RUSH}	-	-	4.6	-	A
	Inrush current	T _{RUSH}	-	0.3	-	ms	[Note 7]
Permissible input ripple voltage	High	V _{RP}	-	-	100	mV _{P.P}	V _{CC} = +12.0V
	Low	V _{TH}	-	-	100	mV	V _{CM} = +1.2V
Differential input threshold voltage	High	V _{TL}	-100	-	-	mV	[Note 6]
	Low	V _{IL}	0	-	1.0	V	[Note 3]
	Input Low voltage	V _{IH}	2.3	-	3.3	V	[Note 3]
	Input High voltage	I _{IL1}	-	-	400	μA	V _I = 0V
	Input leak current (Low)	I _{IL2}	-	-	40	μA	[Note 4] V _I = 0V
	Input leak current (High)	I _{IH1}	-	-	40	μA	[Note 5] V _I = 3.3V
		I _{IH2}	-	-	40	μA	[Note 4] V _I = 3.3V
	Terminal resistor	I _{H2}	-	-	400	μA	[Note 5]
		R _T	-	100	-	Ω	[Note 5] Differential input

[Note] V_{CM}: Common mode voltage of LVDS driver.

[Note 1]

Input voltage sequences

- 0 < t₁ ≅ 20ms
- 10 < t₂ ≅ 20ms
- 10 < t₃ ≅ 50ms
- 0 < t₄ ≅ 1s
- t₅ ≅ 200ms is
- t₆ ≅ 0
- t₇ ≅ 300ms

Dip conditions for supply voltage

- a) 6.5V V_{CC} < 10.8V
- td ≅ 10ms
- b) V_{CC} < 6.5V

Dip conditions for supply voltage

based on input voltage sequence.

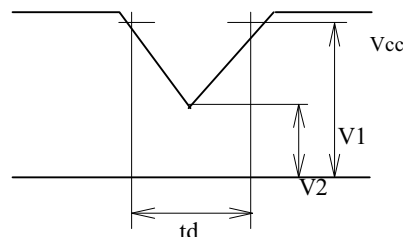
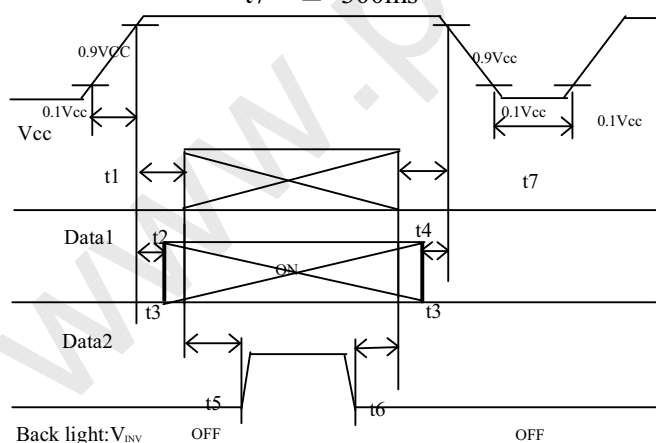

V₁: 10.8V
V₂: 6.5V

※ Data1: ACK±, AIN0±, AIN1±, AIN2±, AIN3±, AIN4±, BCK±, BIN0±, BIN1±, BIN2±, BIN3±, BIN4

*V_{CM} voltage pursues the sequence mentioned above

※ Data2: SELLVDS, FRAME, O/S_SET

[Note] About the relation between data input and back light lighting, please base on the above-mentioned input sequence. When back light is switched on before panel operation or after a panel operation stop, it may not display normally. But this phenomenon is not based on change of an incoming signal, and does not give damage to a liquid crystal display.

[Note 2] Typical current situation: 256 gray-bar patterns. ($V_{CC} = +12.0V$)

The explanation of RGB gray scale is seen in section 8.

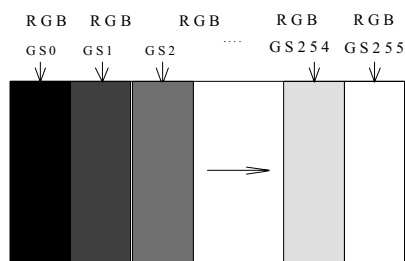

$V_{CC} = +12.0V$
 $CK = 74.25MHz$
 $Th = 14.8\mu s$

[Note 3] SELLVDS, FRAME, O/S_SET

[Note 4] O/S_SET

[Note 5] FRAME, SELLVDS

[Note 6] ACK_{\pm} , $AIN0_{\pm}$, $AIN1_{\pm}$, $AIN2_{\pm}$, $AIN3_{\pm}$, $AIN4_{\pm}$, BCK_{\pm} , $BIN0_{\pm}$, $BIN1_{\pm}$, $BIN2_{\pm}$, $BIN3_{\pm}$, $BIN4_{\pm}$

[Note 7] $V_{CC}12V$ inrush current waveform

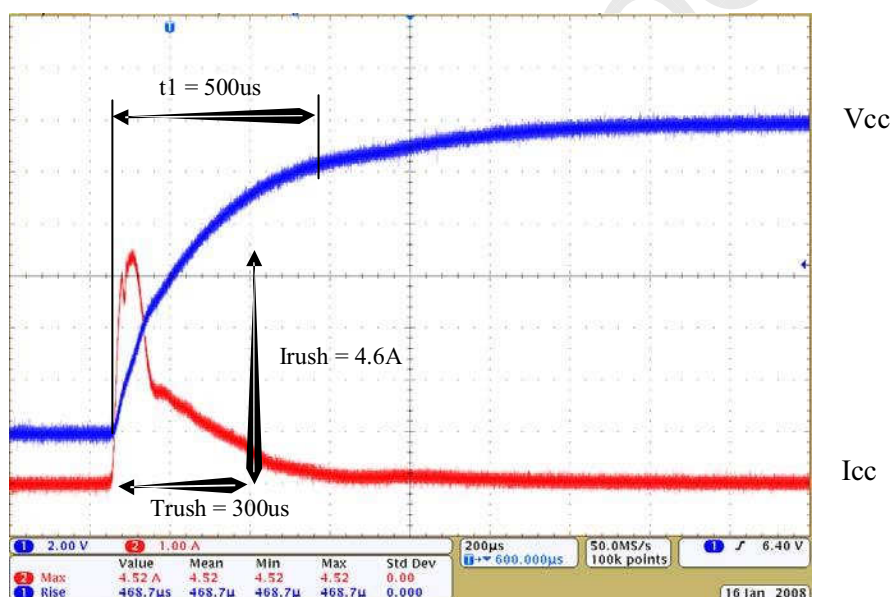

7. Timing characteristics of input signals

7.1. Timing characteristics

Timing diagrams of input signal are shown in Fig.2.

Parameter	Symbol	Min.	Typ.	Max.	Unit	Remark
Clock	Frequency	1/Tc	67	74.25	76	MHz
Data enable signal	Horizontal period	TH	1050	1100	1200	clock
			14.2	14.8	16.1	μ s
	Horizontal period (High)	THd	960	960	960	clock
	Vertical period	TV	1109	1125	1200	line
Vertical period (High)	TVd	1080	1080	1080	line	

[Note]-When vertical period is very long, flicker and etc. may occur.

-Please turn off the module after it shows the black screen.

-Please make sure that length of vertical period should become of an integral multiple of horizontal length of period. Otherwise, the screen may not display properly.

-As for your final setting of driving timing, we will conduct operation check test at our side, please inform your final setting.

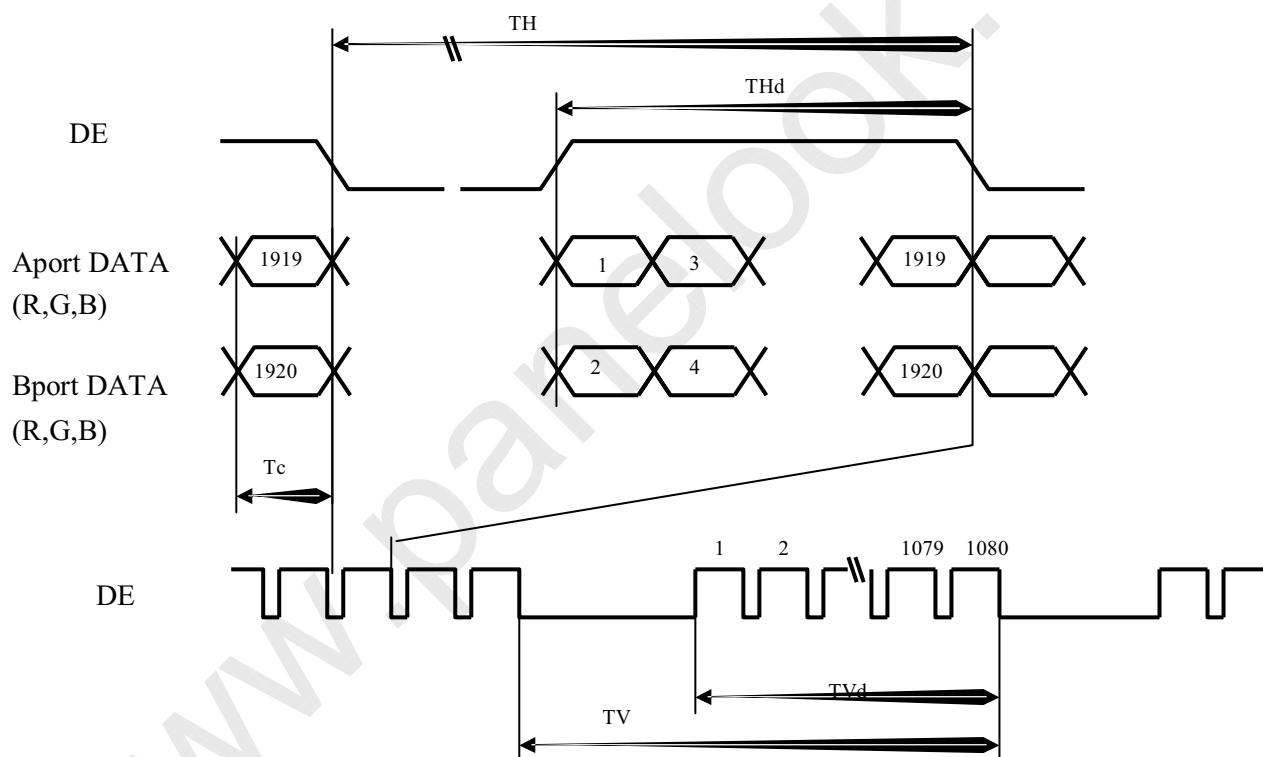
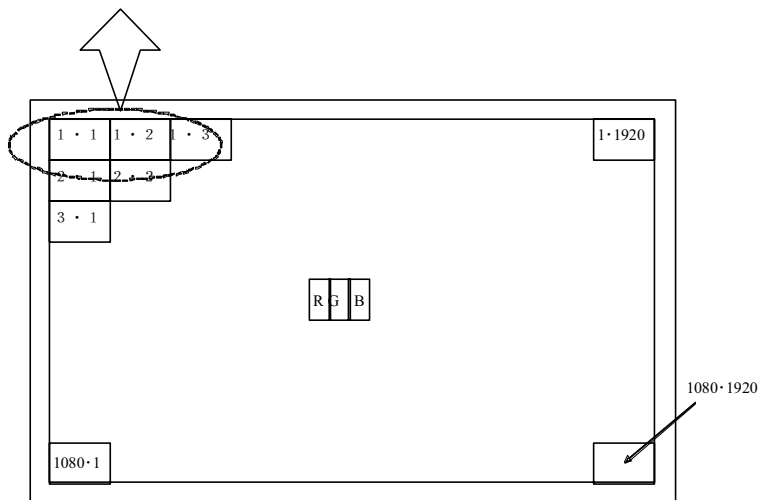
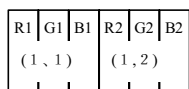

Fig.2 Timing characteristics of input signals



7.2. Input data signal and display position on the screen



Display position of Dat (V,H)

www.panelook.com

8. Input Signal, Basic Display Colors and Gray Scale of Each Color

Colors & Gray scale	Gray Scale	Data signal																											
		R0 R1 R2 R3 R4 R5 R6 R7 R8 R9 G0 G1 G2 G3 G4 G5 G6 G7 G8 G9 B0 B1 B2 B3 B4 B5 B6 B7 B8 B9																											
Basic Color	Black	-	0 0																										
	Blue	-	0 1 1 1 1 1 1																										
	Green	-	0 0 0 0 0 0 0 0 0 0 0 0 1 1 1 1 1 1 1 1 1 1 1 1 1 1 0 0 0 0 0 0																										
	Cyan	-	0 0 0 0 0 0 0 0 0 0 0 0 1																										
	Red	-	1 1 1 1 1 1 1 1 1 1 1 1 0																										
	Magenta	-	1 1 1 1 1 1 1 1 1 1 1 1 0 0 0 0 0 0 0 0 0 0 0 0 0 0 0 0 1 1 1 1																										
	Yellow	-	1 0 0 0 0 0 0																										
	White	-	1 1																										
Gray Scale of Red	Black	GS0	0 0																										
	Darker	GS1	1 0																										
		GS2	0 1 0																										
		↓	↓																										
		↓	↓																										
	Brighter	GS1021 1	0 1 1 1 1 1 1 1 1 1 1 1 0																										
		GS1022 0	1 1 1 1 1 1 1 1 1 1 1 1 0																										
	Red	GS1023 1	1 1 1 1 1 1 1 1 1 1 1 1 0																										
Gray Scale of Green	Black	GS0	0 0																										
	Darker	GS1	0 0 0 0 0 0 0 0 0 0 0 0 1 0 0 0 0 0 0 0 0 0 0 0 0 0 0 0 0 0 0 0																										
		GS2	0 0 0 0 0 0 0 0 0 0 0 0 0 1 0 0 0 0 0 0 0 0 0 0 0 0 0 0 0 0 0 0																										
		↓	↓																										
		↓	↓																										
	Brighter	GS1021 0	0 0 0 0 0 0 0 0 0 0 0 0 1 0 1 1 1 1 1 1 1 1 1 1 1 1 0 0 0 0 0 0																										
		GS1022 0	0 0 0 0 0 0 0 0 0 0 0 0 0 1 1 1 1 1 1 1 1 1 1 1 1 1 0 0 0 0 0 0																										
	Green	GS1023 0	0 0 0 0 0 0 0 0 0 0 0 0 1 1 1 1 1 1 1 1 1 1 1 1 1 1 0 0 0 0 0 0																										
Gray Scale of Blue	Black	GS0	0 0																										
	Darker	GS1	0 1 0 0 0 0																										
		GS2	0 1 0 0 0																										
		↓	↓																										
		↓	↓																										
	Brighter	GS1021 0	0 1 1 1 1 1																										
		GS1022 0	0 1 1 1 1																										
	Blue	GS1023 0	0 1 1 1 1																										

0: Low level voltage, 1: High level voltage.

Each basic color can be displayed in 1024 gray scales from 10 bits data signals. According to the combination of total 30 bits data signals, the TBD-color display can be achieved on the screen.

9. Optical characteristics

$T_a=25^{\circ}\text{C}$, $V_{cc}=12.0\text{V}$, $V_{INV}=24.0\text{V}$, $V_{BRT}=100\%$, Timing:60Hz(typ. value)

Parameter		Symbol	Condition	Min.	Typ.	Max.	Unit	Remark
Viewing angle range	Horizontal	θ_{21} θ_{22}	$CR \geq 10$	70	88	-	Deg.	[Note1,4]
	Vertical	θ_{11} θ_{12}		70	88	-	Deg.	
Contrast ratio		CRn	$\theta = 0 \text{ deg.}$	1000	1500	-		[Note2,4]
Response time		τ_r		-	6	-	ms	[Note3,4,5]
Chromaticity	White	x		0.242	0.272	0.302	-	[Note4]
		y		0.247	0.277	0.307	-	
	Red	x		0.610	0.640	0.670	-	
		y		0.300	0.330	0.360	-	
	Green	x		0.250	0.280	0.310	-	
		y		0.570	0.600	0.630	-	
	Blue	x		0.120	0.150	0.180	-	
		y		0.030	0.060	0.090	-	
Luminance		White	360	450	-	-		
Luminance uniformity	White	δw	-	-	1.25	cd/m^2	[Note 6]	

Measurement condition: Set the value of V_{BRT} to maximum luminance of white.

*The measurement shall be executed 60 minutes after lighting at rating.

[Note]The optical characteristics are measured using the following equipment.

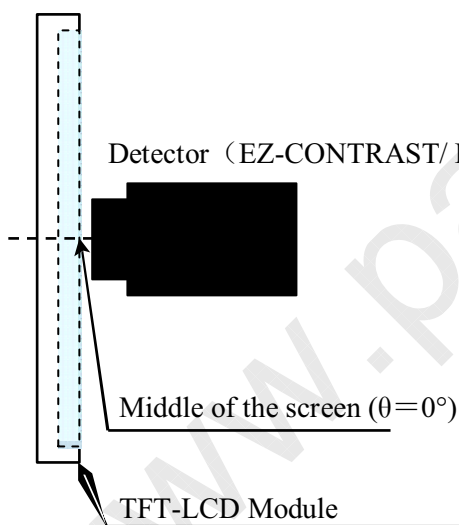

Fig.4-1 Measurement of viewing angle range and Response time.

Viewing angle range: EZ-CONTRAST

Response time: Photodiode

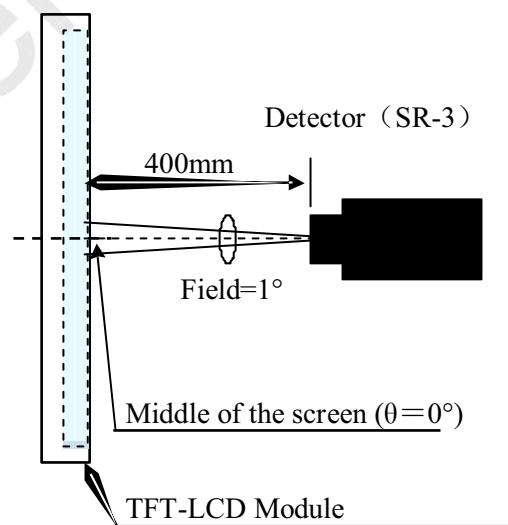
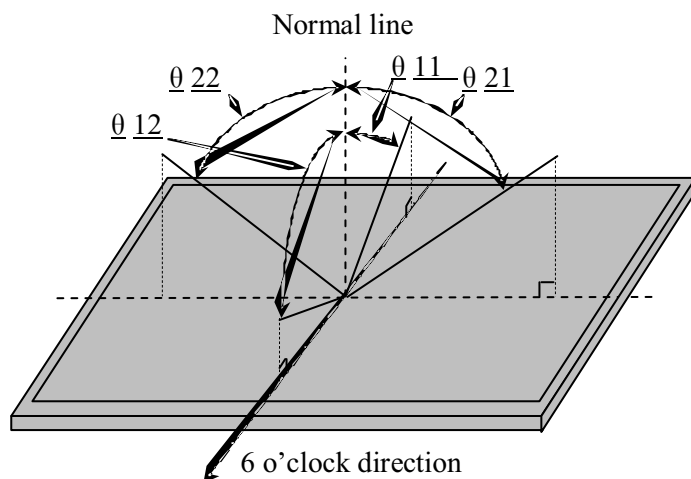

Fig.4-2 Measurement of Contrast, Luminance, Chromaticity.

[Note 1]Definitions of viewing angle range :



[Note 2]Definition of contrast ratio :

The contrast ratio is defined as the following.

$$\text{Contrast Ratio} = \frac{\text{Luminance (brightness) with all pixels white}}{\text{Luminance (brightness) with all pixels black}}$$

[Note 3]Definition of response time

The response time (τ_d and τ_r) is defined as the following figure and shall be measured by switching the input signal for “any level of gray (0%, 25%, 50%, 75% and 100%)” and “any level of gray (0%, 25%, 50%, 75% and 100%)”.

	0%	25%	50%	75%	100%
0%		tr:0%-25%	tr:0%-50%	tr:0%-75%	tr:0%-100%
25%	td: 25%-0%		tr: 25%-50%	tr25%-75%	tr: 25%-100%
50%	td: 50%-0%	td: 50%-25%		tr: 50%-75%	tr: 50%-100%
75%	td: 75%-0%	td: 75%-25%	td: 75%-50%		tr: 75%-100%
100%	td: 100%-0%	td: 100%-25%	td: 100%-50%	td:100%-75%	

t*:x-y...response time from level of gray(x) to level of gray(y)

$$\tau_r = \Sigma(\text{tr}:x-y)/10, \tau_d = \Sigma(\text{td}:x-y)/10$$

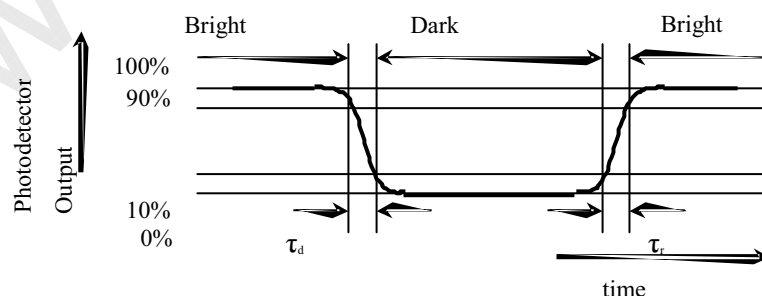

[Note 4]This shall be measured at center of the screen.

[Note 5] This value is valid when O/S driving is used at typical input time value.

[Note 6] Definition of white uniformity ;

White uniformity is defined as the following with five measurements. (A~ E)

$$\delta_w = \frac{\text{Maximum luminance of five points (brightness)}}{\text{Minimum luminance of five points (brightness)}}$$

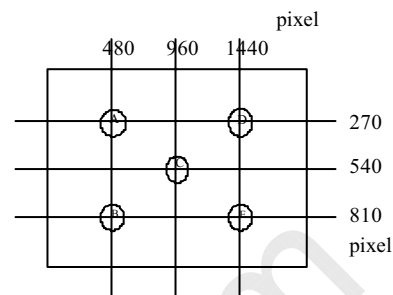

10. Handling Precautions of the module

- Be sure to turn off the power supply when inserting or disconnecting the cable.
- This product is using the parts (inverter, CCFT etc), which generate the high voltage. Therefore, during operating, please don't touch these parts.
- Brightness control voltage is switched for "ON" and "OFF", as shown in Fig.4. Voltage difference generated by this switching, ΔV_{INV} , may affect a sound output, etc. when the power supply is shared between the inverter and its surrounding circuit. So, separate the power supply of the inverter circuit with the one of its surrounding circuit.

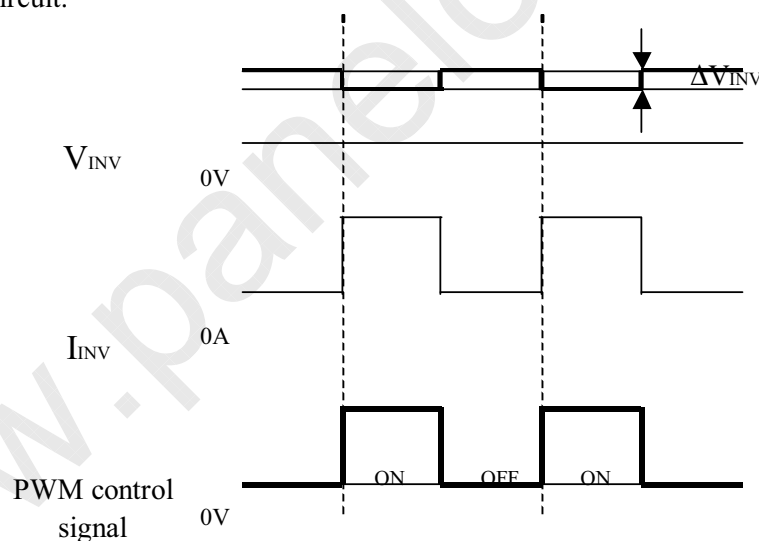

Fig.4 Brightness control voltage.

*Since inverter board's GND is not connected to the frame of the LCD module, please connect it with the Customer's GND of inverter power supply.

- Be sure to design the cabinet so that the module can be installed without any extra stress such as warp or twist.
- Since the front polarizer is easily damaged, pay attention not to scratch it.
- Since long contact with water may cause discoloration or spots, wipe off water drop immediately.
- When the panel surface is soiled, wipe it with absorbent cotton or other soft cloth.
- Since the panel is made of glass, it may break or crack if dropped or bumped on hard surface. Handle with care.

- i) Since CMOS LSI is used in this module, take care of static electricity and take the human earth into consideration when handling.
- j) The module has some printed circuit boards (PCBs) on the back side, take care to keep them form any stress or pressure when handling or installing the module; otherwise some of electronic parts on the PCBs may be damaged.
- k) Observe all other precautionary requirements in handling components.
- l) When some pressure is added onto the module from rear side constantly, it causes display non-uniformity issue, functional defect, etc. So, please avoid such design.
- m) When giving a touch to the panel at power on supply, it may cause some kinds of degradation. In that case, once turn off the power supply, and turn on after several seconds again, and that is disappear.
- n) When handling LCD modules and assembling them into cabinets, please be noted that long-term storage in the environment of oxidization or deoxidization gas and the use of such materials as reagent, solvent, adhesive, resin, etc. which generate these gasses, may cause corrosion and discoloration of the LCD modules.
- o) This LCD module is designed to prevent dust from entering into it. However, there would be a possibility to have a bad effect on display performance in case of having dust inside of LCD module. Therefore, please ensure to design your TV set to keep dust away around LCD module.

11. Packing form

- a) Piling number of cartons:2 maximum
- b) Packing quantity in one carton:3pcs
- c) Carton size:1320(W)× 300(D) × 830(H)
- d) Total mass of one carton filled with full modules: 75kg(Max)

12. Reliability test item

No.	Test item	Condition
1	High temperature storage test	Ta=60°C 240h
2	Low temperature storage test	Ta=-25°C 240h
3	High temperature and high humidity operation test	Ta=40°C ; 95%RH 240h (No condensation)
4	High temperature operation test	Ta=50°C 240h
5	Low temperature operation test	Ta=0°C 240h
6	Vibration test (non-operation)	Frequency: 10~57Hz/Vibration width (one side): 0.075mm : 58~500Hz/Acceleration: 9.8 m/s ² Sweep time: 11 minutes Test period: 3 hours (1h for each direction of X, Y, Z)
7	Shock test (non-operation)	Maximum acceleration: 294m/s ² Pulse width: 11ms, sinusoidal half wave Direction: +/-X, +/-Y, +/-Z, once for each direction.
8	ESD	* At the following conditions, it is a thing without incorrect operation and destruction. (1)Non-operation: Contact electric discharge ±10kV Non-contact electric discharge ±20kV (2)Operation Contact electric discharge ±8kV Non-contact electric discharge ±15kV Conditions: 150pF, 330ohm

[Result evaluation criteria]

Under the display quality test condition with normal operation state, there shall be no change, which may affect practical display function.

13. Others

1) Lot No. Label ;

The label that displays SHARP, product model (LK520D1LH00), a product number is stuck on the back of the module.

【LK520D1LH00X,T】 NSEC PRODUCTION



How to express Lot No.

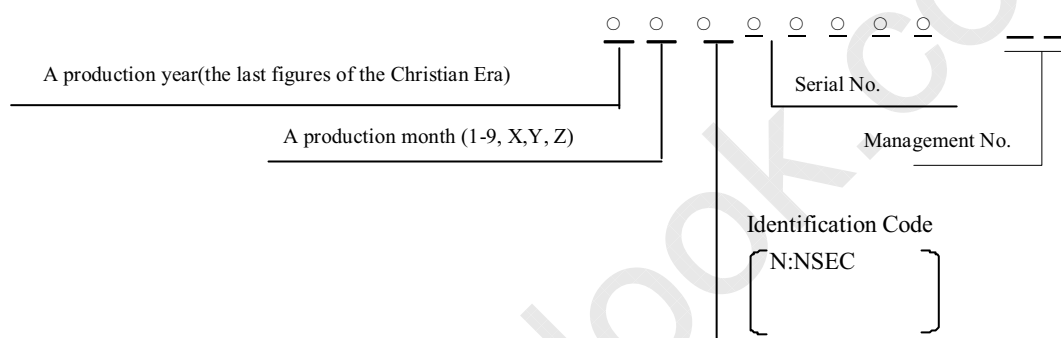

2) Packing Labe

【LK520D1LH00】

社内品番: (4 S) LK520D1LH00X(orT)(①)

Bar code

Lot NO. (1 T) 2 0 0 8 . * . * * (②)

Bar code

Quantity: (Q) 8 p c s (③)

Bar code

ユーザ品番 :

シャープ物流用ラベルです。

- ① Management No.
- ② Lot No. (Date)
- ③ Quantity

3) Adjusting volume has been set optimally before shipment, so do not change any adjusted value.

If adjusted value is changed, the specification may not be satisfied.

4) Disassembling the module can cause permanent damage and should be strictly avoided.

5) Please be careful since image retention may occur when a fixed pattern is displayed for a long time.

- 6) The chemical compound, which causes the destruction of ozone layer, is not being used.
- 7) Cold cathode fluorescent lamp in LCD PANEL contains a small amount of mercury. Please follow local ordinances or regulations for disposal. This sentence is displayed on the backside of the module.

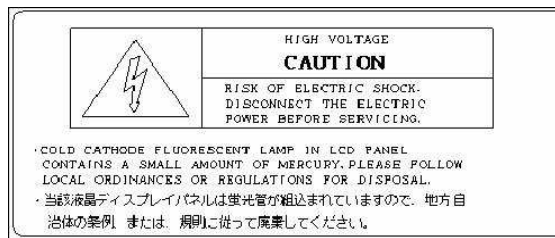

- 8) When any question or issue occurs, it shall be solved by mutual discussion.
- 9) This module is corresponded to RoHS.

14. Carton storage condition

	Temperature	C to 40°C
	Humidity	95%RH or less
	Reference condition	: 20°C to 35°C, 85%RH or less (summer) : 5°C to 15°C, 85%RH or less (winter) • the total storage time (40°C,95%RH) : 240H or less
	Sunlight	Be sure to shelter a product from the direct sunlight.
	Atmosphere	Harmful gas, such as acid and alkali which bites electronic components and/or wires must not be detected.
	Notes	Be sure to put cartons on palette or base, don't put it on floor, and store them with removing from wall Please take care of ventilation in storehouse and around cartons, and control changing temperature is within limits of natural environment
	Storage life	1 year