

1. Application

This specification applies to the color 52.0" TFT-LCD module LK520D3LB1S.

* This specification is proprietary products of SHARP CORPORATION ("SHARP") and includes materials protected under copyright of SHARP. Do not reproduce or cause any third party to reproduce them in any form or by any means, electronic or mechanical, for any purpose, in whole or in part, without the express written permission of SHARP.

* In case of using the device for applications such as control and safety equipment for transportation (aircraft, trains, automobiles, etc.), rescue and security equipment and various safety related equipment which require higher reliability and safety, take into consideration that appropriate measures such as fail-safe functions and redundant system design should be taken.

* Do not use the device for equipment that requires an extreme level of reliability, such as aerospace applications, telecommunication equipment (trunk lines), nuclear power control equipment and medical or other equipment for life support.

* SHARP assumes no responsibility for any damage resulting from the use of the device that does not comply with the instructions and the precautions specified in these specification.

* Contact and consult with a SHARP sales representative for any questions about this device.

2. Overview

This module is a color active matrix LCD module incorporating amorphous silicon TFT (Thin Film Transistor). It is composed of a color TFT-LCD panel, driver ICs, control circuit, power supply circuit, LED drive circuit and back light system etc. Graphics and texts can be displayed on a 1920 × RGB × 1080 dots panel with one billion colors by using 10bit LVDS (Low Voltage Differential Signaling) to interface, +12V of DC supply voltages.

This module also includes the LED-PWB to drive the LED. ($\pm 120\text{mA}$ of DC supply current)

And in order to improve the response time of LCD, this module applies the Over Shoot driving (O/S driving) technology for the control circuit. In the O/S driving technology, signals are being applied to the Liquid Crystal according to a pre-fixed process as an image signal of the present frame when a difference is found between image signal of the previous frame and that of the current frame after comparing them.

With this technology, image signals can be set so that liquid crystal response completes within one frame. As a result, motion blur reduces and clearer display performance can be realized.

This LCD module also adopts Double Frame Rate driving method including FRC (Frame Rate Control) function on the control circuit. Therefore the input signal to this LCD module is Single Frame Rate, but the output is Double-Frame Rate picture (inserting the intermediate image which is generated by the FRC).

With combination of these technologies, motion blur can be reduced and clearer display performance can be realized.

3. Mechanical Specifications

Parameter	Specifications	Unit
Display size	132.174 (Diagonal)	cm
	52.0 (Diagonal)	inch
Active area	1152(H) x 648 (V)	mm
Pixel Format	1920(H) x 1080(V) (1pixel = R + G + B dot)	pixel
Pixel pitch	0.600(H) x 0.600 (V)	mm
Pixel configuration	R, G, B vertical stripe	
Display mode	Normally black	
Unit Outline Dimensions (*1)	1227 (W) x 741 (H) x 27.6(D)	mm
Mass	14.5	kg
Surface treatment	Anti glare (Haze 7.3) Hard coating: 3H	

(*1) Outline dimensions are shown in Fig.17 (excluding protruding portion)

4. Input Terminals

4.1. TFT panel driving

CN1 (Interface signals and +12V DC power supply) (Shown in Fig.1)

Using connector : FI-RNE51SZ-HF (Japan Aviation Electronics Ind., Ltd.)

Mating connector : FI-RE51HL, FI-RE51CL (Japan Aviation Electronics Ind., Ltd.)

Mating LVDS transmitter : THC63LVD1023 or equivalent device

Pin No.	Symbol	Function	Remark
1	VCC	+12V Power Supply	
2	VCC	+12V Power Supply	
3	VCC	+12V Power Supply	
4	VCC	+12V Power Supply	
5	VCC	+12V Power Supply	
6	OPEN		
7	GND		
8	GND		
9	GND		
10	AIN0-	Aport (-)LVDS CH0 differential data input	
11	AIN0+	Aport (+)LVDS CH0 differential data input	
12	AIN1-	Aport (-)LVDS CH1 differential data input	
13	AIN1+	Aport (+)LVDS CH1 differential data input	
14	AIN2-	Aport (-)LVDS CH2 differential data input	
15	AIN2+	Aport (+)LVDS CH2 differential data input	
16	GND		
17	ACK-	Aport LVDS Clock signal(-)	
18	ACK+	Aport LVDS Clock signal(+)	
19	GND		
20	AIN3-	Aport (-)LVDS CH3 differential data input	
21	AIN3+	Aport (+)LVDS CH3 differential data input	
22	AIN4-	Aport (-)LVDS CH4 differential data input	
23	AIN4+	Aport (+)LVDS CH4 differential data input	
24	GND		
25	BIN0-	Bport (-)LVDS CH0 differential data input	
26	BIN0+	Bport (+)LVDS CH0 differential data input	
27	BIN1-	Bport (-)LVDS CH1 differential data input	
28	BIN1+	Bport (+)LVDS CH1 differential data input	
29	BIN2-	Bport (-)LVDS CH2 differential data input	
30	BIN2+	Bport (+)LVDS CH2 differential data input	
31	GND		
32	BCK-	Bport LVDS Clock signal(-)	
33	BCK+	Bport LVDS Clock signal(+)	
34	GND		
35	BIN3-	Bport (-)LVDS CH3 differential data input	
36	BIN3+	Bport (+)LVDS CH3 differential data input	
37	BIN4-	Bport (-)LVDS CH4 differential data input	
38	BIN4+	Bport (+)LVDS CH4 differential data input	
39	GND		
40	I2C_SCL	I2C CLK	
41	I2C_SDA	I2C Data	
42	Open		Open
43	B_INT	I2C bus enable (H:enable, L:disable) [Note 1]	Pull down : (GND)
44	PANEL_SEL	(PANEL Sel Signal) [Note 2]	
45	FRC_PWR_CTRL	Power on sequence(DC/DC On Signal)	Pull down : (GND)

46	SA_MODE	SA Mode Sel Signal (L:Set mode, H:Stand alone(SA) mode)	Pull up 3.3V
47	PANEL_ON	Power on sequence	Pull down : (GND)
48	FRC_RST	FRC IC RESET	Pull down : (GND)
49	Open		Open
50	TCON_RDY	TCON ready signal (H:OK, L:NG)	
51	Open		

[Note] GND of a liquid crystal panel drive part has connected with a module chassis.

CN2 (+12V DC power supply)

Using connector : SM04B-PASS (J.S.T.Mfg Co., Ltd.)

Mating connector : (PAP-04V-S) (J.S.T.Mfg Co., Ltd.)

Pin No.	Symbol	Function	Remark
1	VCC	+12V Power Supply	
2	VCC	+12V Power Supply	
3	GND		
4	GND		

[Note 1] B_INT

Pin No.	Symbol	Function
43	B_INT	Select I2C Bus 0: FRC is I2C master. (EEPROM access mode) 1: FRC is I2C slave.(μ com mode(SA_MODE = '1'))

[Note 2] PANEL_SEL

R1	Panel type	Address
Open	Standard	Slave address and Power sequence are standard.

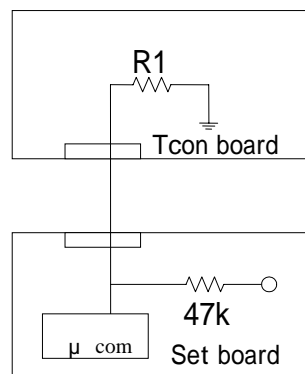

Fig.1 Block diagram of PANEL_SEL

4.2. LVDS Data order

LVDS Mapping	
Data	[JEIDA]
TA0	R4
TA1	R5
TA2	R6
TA3	R7
TA4	R8
TA5	R9
TA6	G4
TB0	G5
TB1	G6
TB2	G7
TB3	G8
TB4	G9
TB5	B4
TB6	B5
TC0	B6
TC1	B7
TC2	B8
TC3	B9
TC4	HSYNC
TC5	VSYNC
TC6	DE (*)
TD0	R2
TD1	R3
TD2	G2
TD3	G3
TD4	B2
TD5	B3
TD6	N/A
TE0	R0
TE1	R1
TE2	G0
TE3	G1
TE4	B0
TE5	B1
TE6	N/A

NA:Not Available

(*)Since the display position is prescribed by the rise of DE(Display Enable)signal, please do not fix DE signal during operation at "High".

4.3. LVDS Mapping

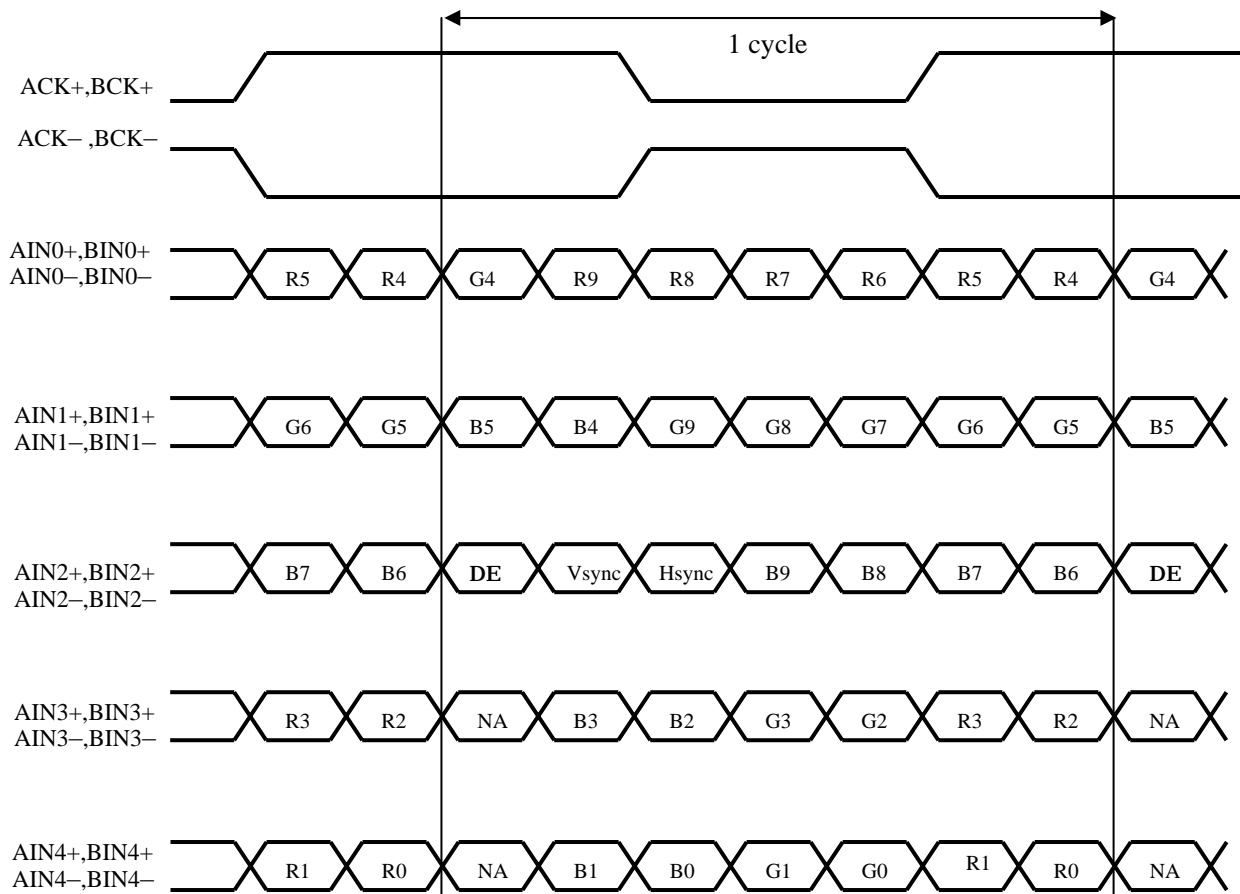

Fig.2 LVDS Mapping

4.4. Panel ID data map

The slave address of EEPROM(24C02) is AA.

No.	Item	Spec(Ex.)	Address	Data	Remark
1	Vender code	SHARP	00	03	Select Note1) *Sony use.
2	Screen size	52"	01	34	HEX data
3	H-Resolution	1920	02,03	07,80	HEX data
4	V-Resolution	1080	04,05	04,38	HEX data
5	V-Frequency	100/120Hz	06	01	Select Note2)
6	Data format	10bit	07	02	Select Note3)
7	Revision code	001	FA ~ FF	30,30,31,00,00,00	ASCII Note4) *Sony use.
8	Part Number	LK520D3LB1S	E0 ~ EF	4C,4B,35,32,30,44, 33,4C,42,31,53,00, 00,00,00,00	ASCII Note4) *Sony use.

[Note 1] Vender code

Vender code	Data
-	00
-	01
-	02
SHARP	03
-	04
-	05
-	06

[Note 2] V-Frequency

V-Frequency	Data
50/60Hz	00
100/120Hz	01
200/240Hz	02

[Note 3] Data format

Data format	Data
6bit	00
8bit	01
10bit	02

[Note 4] An empty address inputs "00".

4.5. Interface block diagram

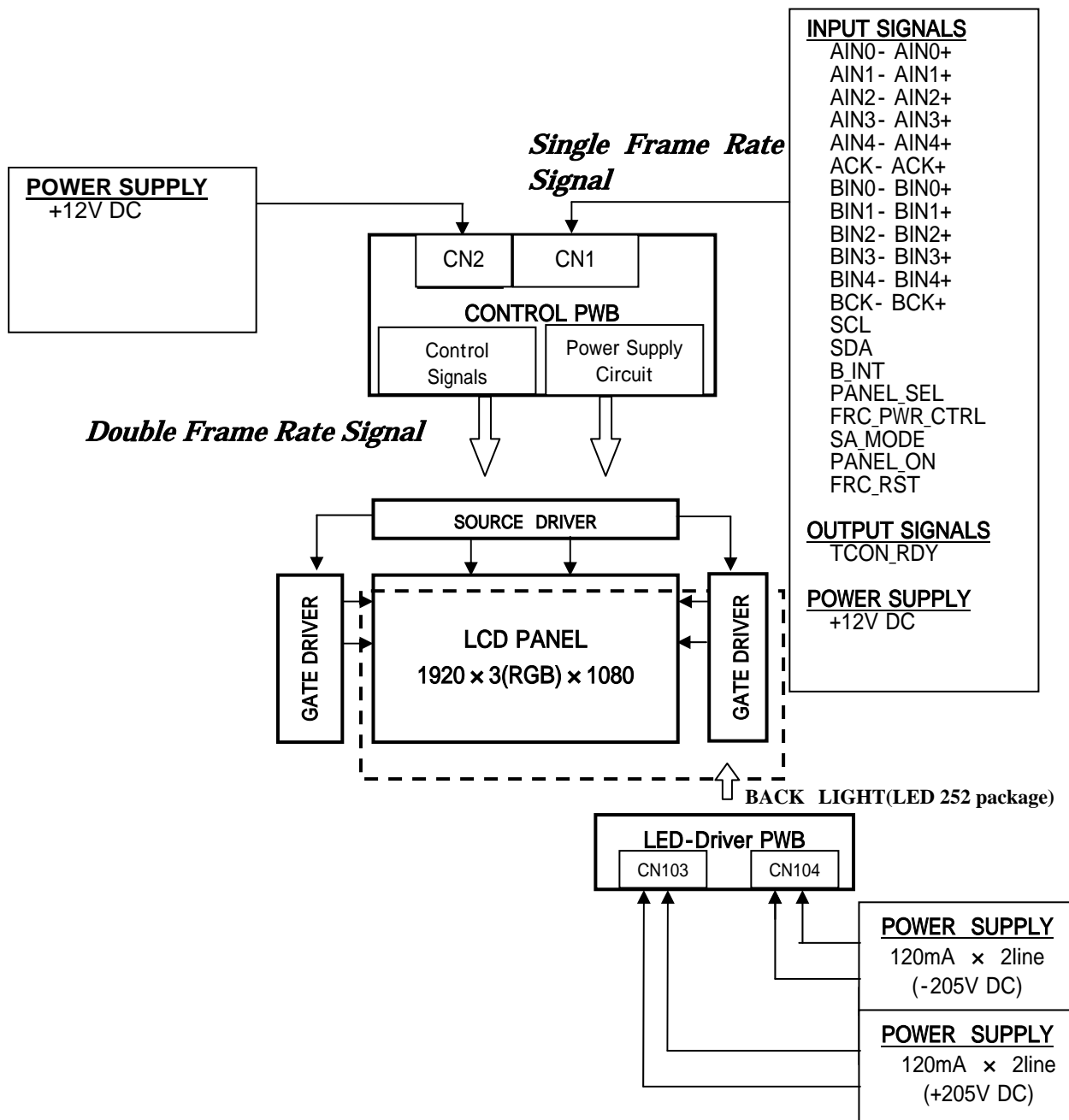

Fig.3 Interface block diagram

4.6. Backlight driving

CN103 (+120mA DC power supply)

Using connector: 51103-0400 (Molex)

Mating connector: XAP-04V-1 (JST)

Pin No.	Symbol	Function	Remark
1	I_{+LED1}	+120mA	+205V
2	I_{+LED2}		
3	Reserved	-	
4	Reserved	-	

CN104(-120mA DC power supply)

Using connector: 51103-0500 (Molex)

Mating connector: XAP-05V-1 (JST)

Pin No.	Symbol	Function	Remark
1	I_{LED1}	-120mA	-205V
2	I_{LED2}		
3	Reserved	-	
4	Reserved	-	
5	Reserved	-	

4.7. The back light system characteristics

The back light system is edge light type with 252 segment. (LS:4, Die/LS:63packages)

The characteristics of the LED are shown in the following table. The value mentioned below is at the case of one LED.

Item	Symbol	Min.	Typ.	Max.	Unit	Remarks
Life time	T_{LED}	-	50000	-	Hour	[Note]

[Note] LED life time is defined as the time when brightness becomes 50% of the original value in the continuous operation under the $T_a = 25^\circ\text{C}$

5. Absolute Maximum Ratings

Parameter	Symbol	Condition	Ratings	Unit	Remark
Input voltage (for Control and FRC)	V_I	$T_a=25^\circ\text{C}$	-0.3 ~ 3.6	V	[Note 1]
12V supply voltage (for Control)	VCC	$T_a=25^\circ\text{C}$	0 ~ +14	V	
supply current (for LED driver)	I_{LED}	$T_j=25^\circ\text{C}$	150	mA	
supply voltage (for LED driver)	V_{LED}	$T_j=25^\circ\text{C}$	-212 ~ +212	V	
Storage temperature	T_{stg}	-	-25 ~ +60	$^\circ\text{C}$	
Operation temperature (Ambient)	T_{opa}	-	0 ~ +50	$^\circ\text{C}$	

[Note 1] SCL, SDA, B_INT, PANEL_SEL, FRC_PWR_CTRL, SA_MODE, PANEL_ON, FRC_RST

6. Electrical Characteristics

6.1. Control circuit driving

Ta=25 °C

Parameter	Symbol	Min.	Typ.	Max.	Unit	Remark
+12V supply voltage	Supply voltage	Vcc	11	12	13	V [Note 1]
	Current dissipation	Icc	-	1.0	3.5	A [Note 2]
	Inrush current	I _{RUSH1}	-	9.0	-	A
I _{RUSH2}		-	3.0	-	A	t ₁ >5ms
Permissible input ripple voltage	V _{RP}	-	-	100	mV _{P-P}	V _{cc} = +12.0V
Input Low voltage	V _{IL}	0	-	1.0	V	[Note 5]
Input High voltage	V _{IH}	2.3	-	3.6	V	
Input leak current(Low)	I _{IL}			400	uA	V _I =0V
Input leak current(High)	I _{IH}			100	uA	V _I =3.3V
Terminal resistor	R _T	-	100	-	Ω	Differential input
Input Differential voltage	VID	100	-	-	mV	[Note 3]
Differential input common mode voltage	V _{CM}	VID /2	1.2	2.4- VID /2	V	

[Note]V_{CM}: Common mode voltage of LVDS driver.

[Note 1]

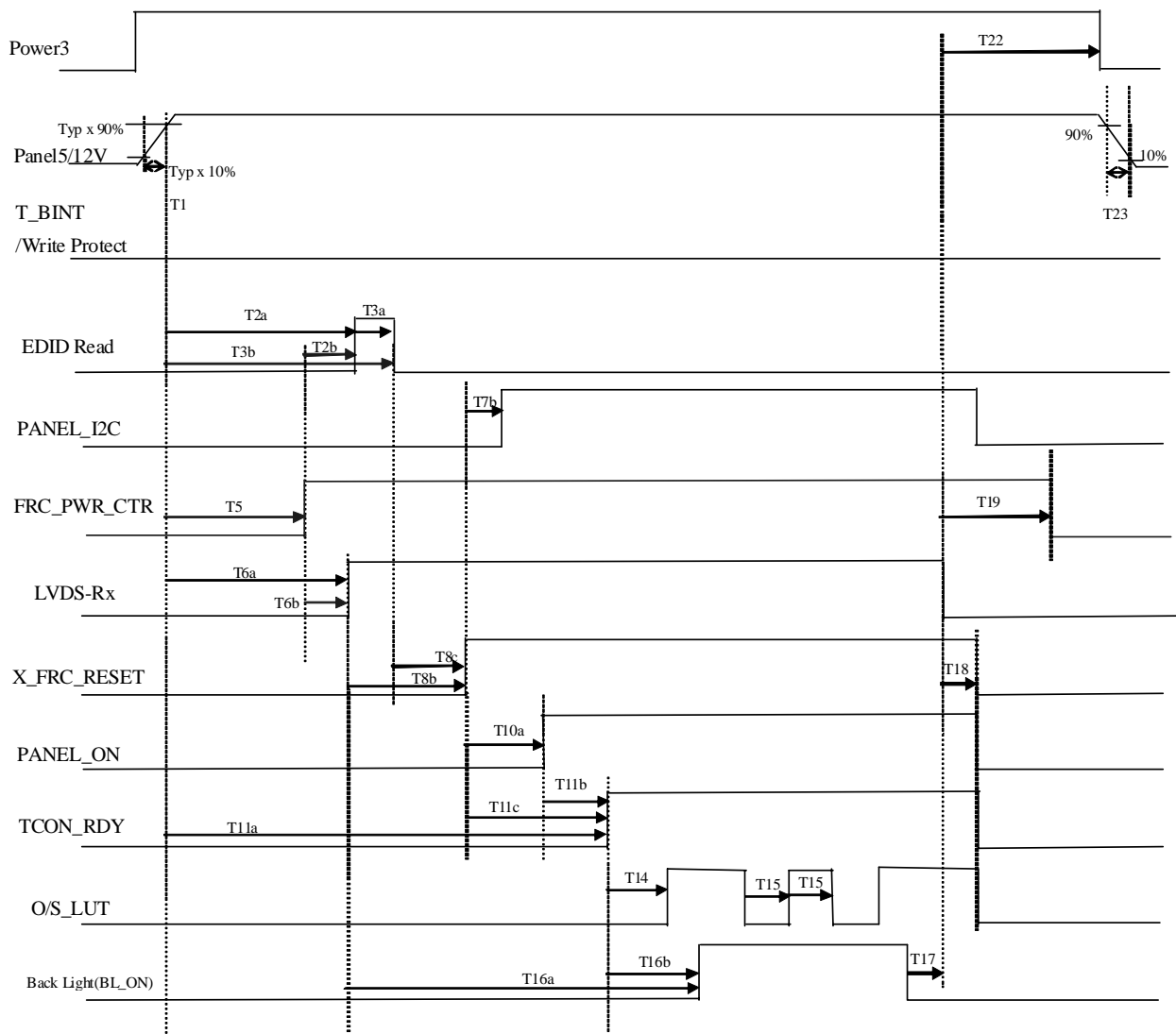

Fig.4 Timing chart of sequence

	Min	Max		Min	Max		Min	Max		Min	Max	Unit
T1	0.47	10	T7b	11		T15	0.1		T22	0		msec
T2b	60		T8b	10		T16b	500		T23	0		
T3b	0	200	T8c	10		T17	100					
T5	10		T10a	20		T18	0	10				
T6b	50		T14	0		T19	0	45				

[Note] About the relation between data input and back light lighting, please base on the above-mentioned input sequence. When back light is switched on before panel operation or after a panel operation stop, it may not display normally. But this phenomenon is not based on change of an incoming signal, and does not give damage to a liquid crystal display.

[Note 2] Typical current situation: 1024 gray-bar patterns. (Vcc = +12.0V)

The explanation of RGB gray scale is seen in section 8.

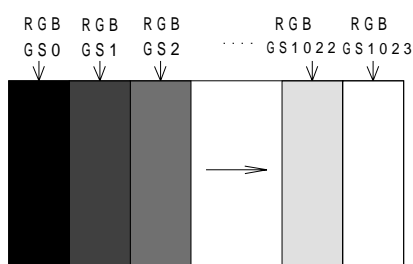

Vcc = +12.0V
CK = 74.25MHz
Th = 14.8μs

Max.current situation: 2H hatching pattern. (Vcc = +12.0V)

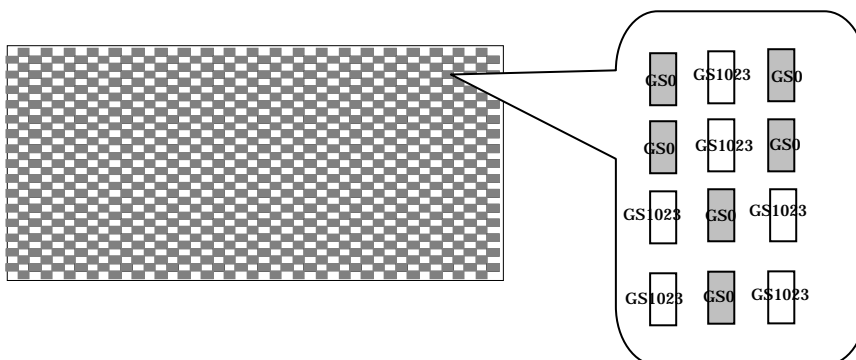

Vcc = +12.0V
CK = 74.25MHz
Th = 14.8μs

Fig.5 Typical/Worst Display pattern

[Note 3]

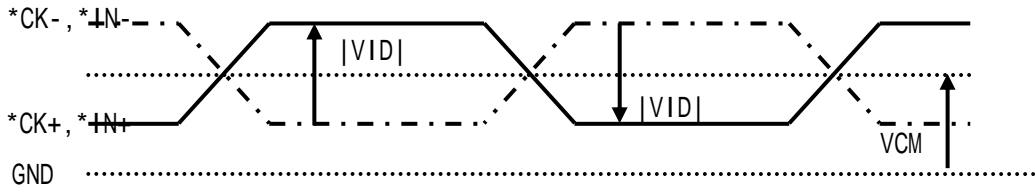

Fig.6 mini-LVDS Amplitude voltage

[Note 4]

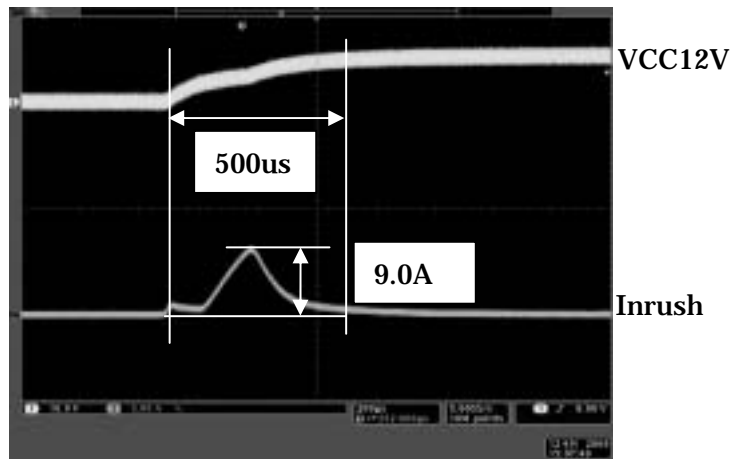

Fig.7 Inrush current

[Note 5] I2C_SCL,I2C_SDA,B_INT,PANEL_SEL,FRC_PWR_CTRL
SA_MODE,PANEL_ON,FRC_RST,TCON_RDY

6.2. LED driving for back light

The back light system is edge light type with LEDs .

Parameter	Symbol	Min.	Typ.	Max.	Unit	Remark
Operating Voltage	V_{op}	± 189	± 205	± 212	V	@ 240mA/module
Operating Current	I_{op}	-	120	-	mA	1 pair Current
		-	240	-	mA	Total current(2 pair)

7. Timing characteristics of input signals

7.1. Timing characteristics

Timing diagrams of input signal are shown.

FRC Input Timing

	Unit	60Hz			50Hz			24x2		
		min.	typ.	max.	min.	typ.	max.	min.	typ.	max.
H_Total	dot	2184	2184	2184	2184	2184	2184	2184	2184	2184
H_Active	dot	1920	1920	1920	1920	1920	1920	1920	1920	1920
H_FP	dot	32	32	32	32	32	32	32	32	32
H_FP	dot	136	136	136	136	136	136	136	136	136
HS_Width	dot	32	32	32	32	32	32	32	32	32
H_BP	dot	200	200	200	200	200	200	200	200	200
H_BP	dot	96	96	96	96	96	96	96	96	96
H_freq	kHz		67.995			67.995			67.995	
V_Total	line	1124	1134	1144	1347	1360	1374	1402	1416	1430
V_Active	line	1080	1080	1080	1080	1080	1080	1080	1080	1080
V_FP	line	24	34	44	247	260	274	302	316	330
VS_Width	line	4	4	4	4	4	4	4	4	4
V_BP	line	16	16	16	16	16	16	16	16	16
V_freq	Hz	59.46	59.96	60.46	49.50	49.97	50.50	47.52	48.02	48.52
PanelCLK	MHz	73.51	74.25	74.99	73.51	74.25	74.99	73.51	74.25	74.99

[Note]-When vertical period is very long, flicker and etc. may occur.

- Please turn off the module after it shows the black screen.
 - Please make sure that length of vertical period should become of an integral multiple of horizontal length of period. Otherwise, the screen may not display properly.
 - As for your final setting of driving timing, we will conduct operation check test at our side, please inform your final setting.
 - It is defined under the input signal condition with SS (60 kHz/ $\pm 2\%$).
- Htotal ; 2184 \pm 1 lines

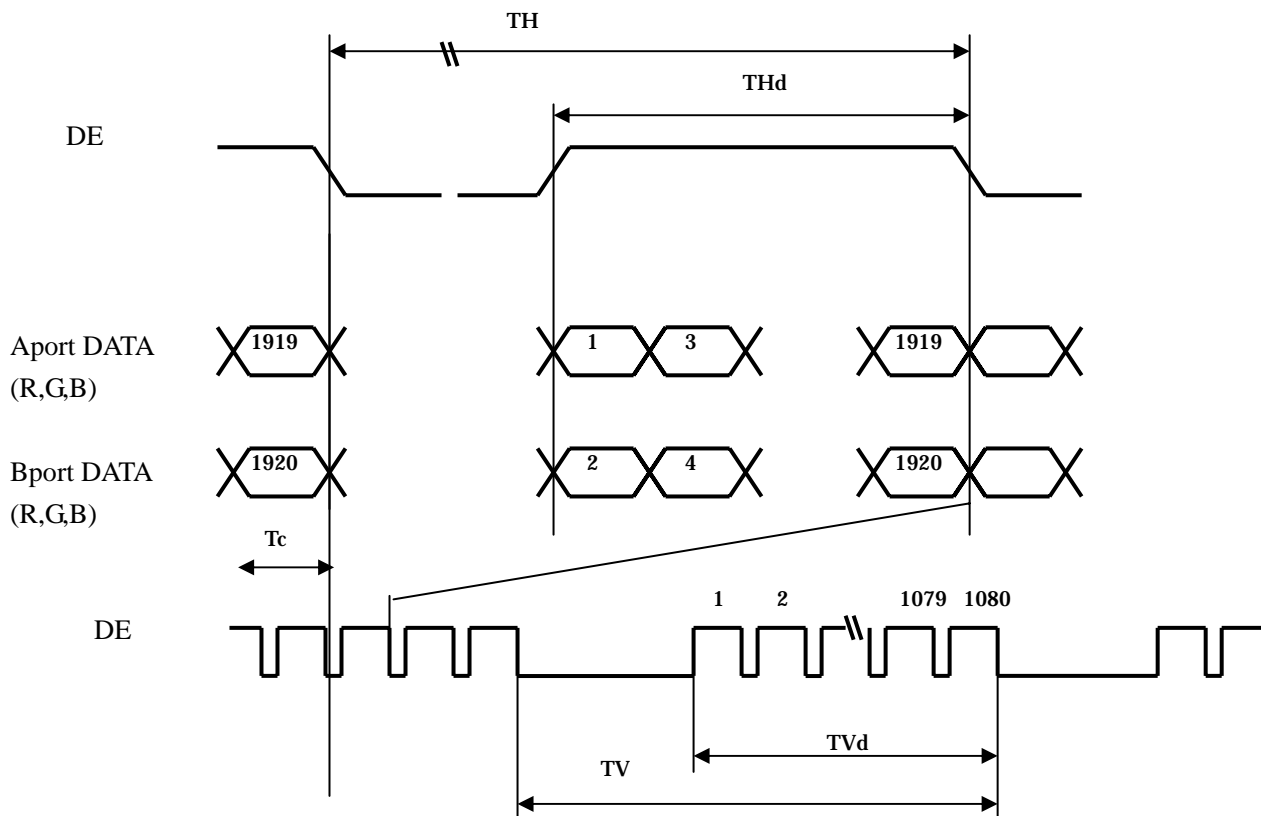

Fig.8 LVDS input timing chart

7.2. Input data signal and display position on the screen

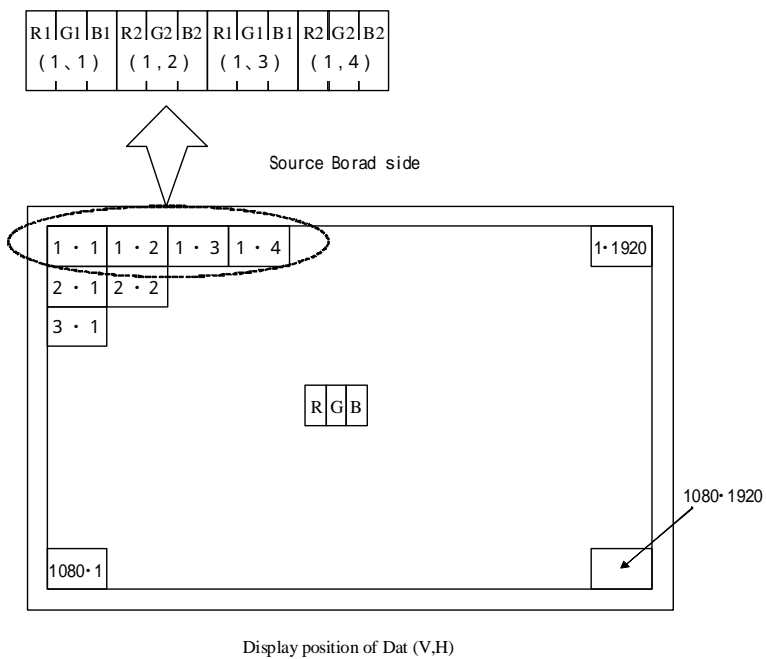

Fig.9 Input data signal and display position on the screen

8. Input Signal, Basic Display Colors and Gray Scale of Each Color

Colors & Gray scale	Data signal																															
	Gray Scale	R0	R1	R2	R3	R4	R5	R6	R7	R8	R9	G0	G1	G2	G3	G4	G5	G6	G7	G8	G9	B0	B1	B2	B3	B4	B5	B6	B7	B8	B9	
Basic Color	Black	–	0	0	0	0	0	0	0	0	0	0	0	0	0	0	0	0	0	0	0	0	0	0	0	0	0	0	0	0	0	0
	Blue	–	0	0	0	0	0	0	0	0	0	0	0	0	0	0	0	0	0	0	0	0	1	1	1	1	1	1	1	1	1	1
	Green	–	0	0	0	0	0	0	0	0	0	1	1	1	1	1	1	1	1	1	1	1	0	0	0	0	0	0	0	0	0	0
	Cyan	–	0	0	0	0	0	0	0	0	0	1	1	1	1	1	1	1	1	1	1	1	1	1	1	1	1	1	1	1	1	1
	Red	–	1	1	1	1	1	1	1	1	1	0	0	0	0	0	0	0	0	0	0	0	0	0	0	0	0	0	0	0	0	0
	Magenta	–	1	1	1	1	1	1	1	1	1	0	0	0	0	0	0	0	0	0	0	0	1	1	1	1	1	1	1	1	1	1
	Yellow	–	1	1	1	1	1	1	1	1	1	1	1	1	1	1	1	1	1	1	1	1	0	0	0	0	0	0	0	0	0	0
	White	–	1	1	1	1	1	1	1	1	1	1	1	1	1	1	1	1	1	1	1	1	1	1	1	1	1	1	1	1	1	1
Gray Scale of Red	Black	GS0	0	0	0	0	0	0	0	0	0	0	0	0	0	0	0	0	0	0	0	0	0	0	0	0	0	0	0	0	0	
	↑	GS1	1	0	0	0	0	0	0	0	0	0	0	0	0	0	0	0	0	0	0	0	0	0	0	0	0	0	0	0	0	
	Darker	GS2	0	1	0	0	0	0	0	0	0	0	0	0	0	0	0	0	0	0	0	0	0	0	0	0	0	0	0	0	0	
	↑	↓					↓									↓													↓			
	↓	↓					↓									↓													↓			
	Brighter	GS1021	1	0	1	1	1	1	1	1	0	0	0	0	0	0	0	0	0	0	0	0	0	0	0	0	0	0	0	0	0	
	↓	GS1022	0	1	1	1	1	1	1	1	0	0	0	0	0	0	0	0	0	0	0	0	0	0	0	0	0	0	0	0	0	
	Red	GS1023	1	1	1	1	1	1	1	1	0	0	0	0	0	0	0	0	0	0	0	0	0	0	0	0	0	0	0	0	0	
Gray Scale of Green	Black	GS0	0	0	0	0	0	0	0	0	0	0	0	0	0	0	0	0	0	0	0	0	0	0	0	0	0	0	0	0		
	↑	GS1	0	0	0	0	0	0	0	1	0	0	0	0	0	0	0	0	0	0	0	0	0	0	0	0	0	0	0	0		
	Darker	GS2	0	0	0	0	0	0	0	0	1	0	0	0	0	0	0	0	0	0	0	0	0	0	0	0	0	0	0	0		
	↑	↓					↓									↓													↓			
	↓	↓					↓									↓													↓			
	Brighter	GS1021	0	0	0	0	0	0	0	1	0	1	1	1	1	1	1	1	1	1	0	0	0	0	0	0	0	0	0	0		
	↓	GS1022	0	0	0	0	0	0	0	0	1	1	1	1	1	1	1	1	1	1	0	0	0	0	0	0	0	0	0	0		
	Green	GS1023	0	0	0	0	0	0	0	1	1	1	1	1	1	1	1	1	1	1	0	0	0	0	0	0	0	0	0	0		
Gray Scale of Blue	Black	GS0	0	0	0	0	0	0	0	0	0	0	0	0	0	0	0	0	0	0	0	0	0	0	0	0	0	0	0			
	↑	GS1	0	0	0	0	0	0	0	0	0	0	0	0	0	0	0	0	0	1	0	0	0	0	0	0	0	0	0			
	Darker	GS2	0	0	0	0	0	0	0	0	0	0	0	0	0	0	0	0	0	0	1	0	0	0	0	0	0	0	0			
	↓	↓					↓									↓													↓			
	↓	↓					↓									↓													↓			
	Brighter	GS1021	0	0	0	0	0	0	0	0	0	0	0	0	0	0	0	0	0	1	0	1	1	1	1	1	1	1	1			
	↓	GS1022	0	0	0	0	0	0	0	0	0	0	0	0	0	0	0	0	0	0	1	1	1	1	1	1	1	1	1			
	Blue	GS1023	0	0	0	0	0	0	0	0	0	0	0	0	0	0	0	0	0	1	1	1	1	1	1	1	1	1	1			

0: Low level voltage, 1: High level voltage.

Each basic color can be displayed in 1021 gray scales from 10 bits data signals. According to the combination of total 30 bits data signals, one billion-color display can be achieved on the screen.

9. Optical characteristics

$T_a=25^{\circ}\text{C}$, $V_{cc}=12.0\text{V}$, LED current= $\pm 120\text{mA}$, Timing:120Hz(typ. value)

Parameter		Symbol	Condition	Min.	Typ.	Max.	Unit	Remark
Viewing angle range	Horizontal	θ_{21} θ_{22}	$CR \geq 10$	70	88	-	Deg.	[Note1,4]
	Vertical	θ_{11} θ_{12}		70	88	-	Deg.	
Contrast ratio		CRn	$\theta=0 \text{ deg.}$	-	5000	-		[Note2,4]
Response time		τ_{DRV}			4	8	msec	[Note3,4,5]
Chromaticity	White	x		0.250	0.280	0.310	-	[Note4]
		y		0.255	0.285	0.315	-	
	Red	x		0.635	0.640	0.645	-	
		y		0.339	0.344	0.349	-	
	Green	x		0.296	0.301	0.306	-	
		y		0.649	0.654	0.659	-	
	Blue	x		0.149	0.154	0.159	-	
		y		0.060	0.065	0.070	-	
Luminance	White	Y_L	370	460	-	cd/m^2		
Luminance uniformity	White	δ_w			0.25		[Note 6]	

Measurement condition: Set the value of LED current= $\pm 120\text{mA}$ of white.

*The measurement shall be executed 60 minutes after lighting at rating.

[Note]The optical characteristics are measured using the following equipment.

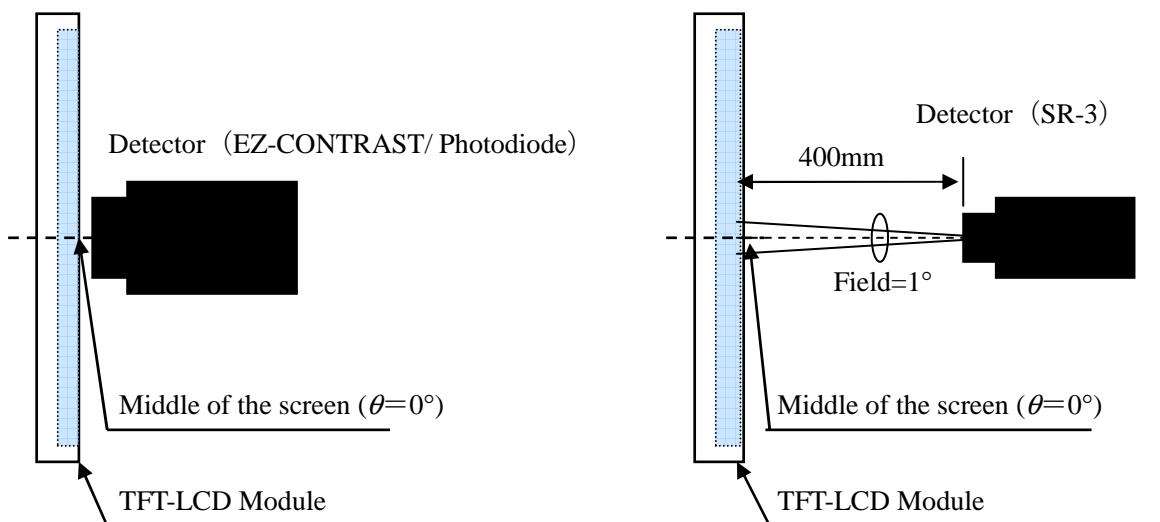

Fig.10-1 Measurement of viewing angle range and Response time.

Viewing angle range: EZ-CONTRAST

Response time: Photodiode

Fig.10-2 Measurement of Contrast, Luminance, Chromaticity.

Fig.10 Optical measuring equipment

[Note 1]Definitions of viewing angle range :

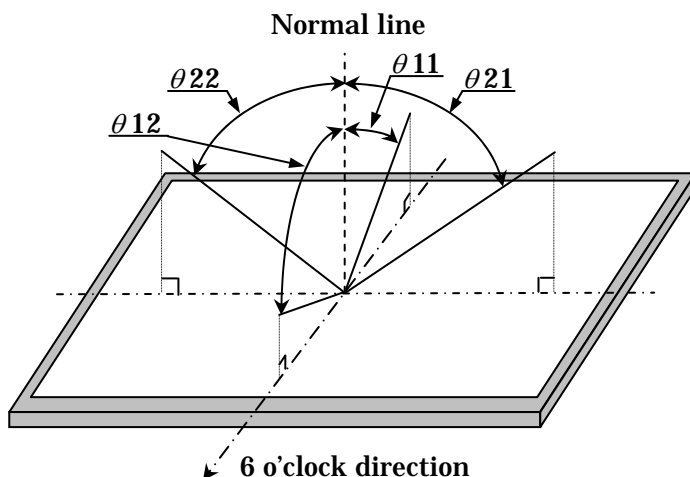

Fig.11 Optical measurement condition

[Note 2]Definition of contrast ratio :

The contrast ratio is defined as the following.

$$\text{Contrast Ratio} = \frac{\text{Luminance (brightness) with all pixels white}}{\text{Luminance (brightness) with all pixels black}}$$

[Note 3]Definition of response time

The response time (T_{DRV}) is defined as the following figure and shall be measured by switching the input signal for “any level of gray (0%, 25%, 50%, 75% and 100%)” and “any level of gray (0%, 25%, 50%, 75% and 100%)”.

	0%	25%	50%	75%	100%
0%		tr:0%-25%	tr:0%-50%	tr:0%-75%	tr:0%-100%
25%	td: 25%-0%		tr: 25%-50%	tr25%-75%	tr: 25%-100%
50%	td: 50%-0%	td: 50%-25%		tr: 50%-75%	tr: 50%-100%
75%	td: 75%-0%	td: 75%-25%	td: 75%-50%		tr: 75%-100%
100%	td: 100%-0%	td: 100%-25%	td: 100%-50%	td:100%-75%	

$t^*:x-y$...response time from level of gray(x) to level of gray(y)

$$\tau_{DRV} = \Sigma(t^*:x-y)/20$$

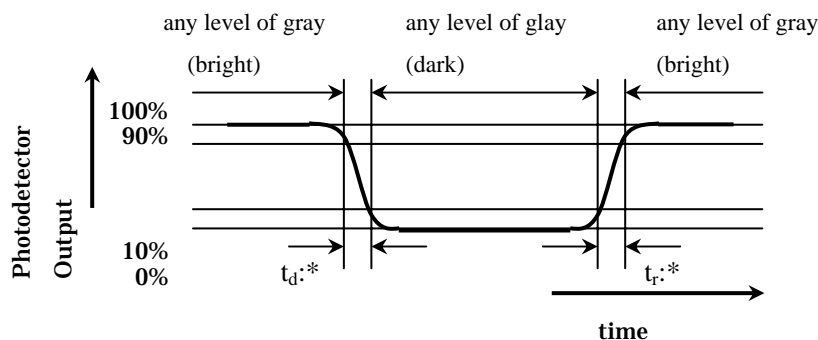

Fig.12 Definition of response time

[Note 4]This shall be measured at center of the screen.

[Note 5] This value is valid when O/S driving is used at typical input time value.

[Note 6] Definition of white uniformity ;

White uniformity is defined as the following with nine measurements. (A~I)

$$\delta_w = \frac{|\text{Maximum or Minimum luminance of nine points} - \text{Luminance of Center point "E"}|}{\text{Luminance of center point "E"}}$$

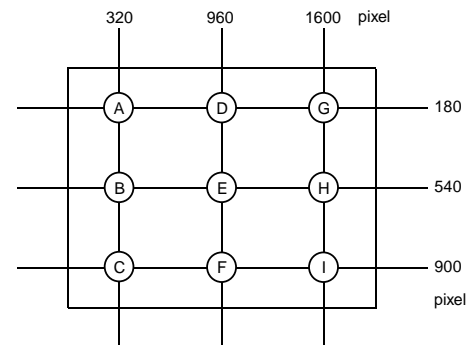

Fig.13 Definition of white uniformity

10. Handling Precautions of the module

- a) Be sure to turn off the power supply when inserting or disconnecting the cable.
- b) Voltage difference generated by this switching, ΔV_{LED} , may affect a sound output, etc. when the power supply is shared between the LED driver and its surrounding circuit. So, separate the power supply of the LED driver circuit with the one of its surrounding circuit.
*Since LED driver board's GND is not connected to the frame of the LCD module, please connect it with the Customer's GND of LED driver power supply.
- c) Be sure to design the cabinet so that the module can be installed without any extra stress such as warp or twist.
- d) Since the front polarizer is easily damaged, pay attention not to scratch it.
- e) Since long contact with water may cause discoloration or spots, wipe off water drop immediately.
- f) When the panel surface is soiled, wipe it with absorbent cotton or other soft cloth.
- g) Since the panel is made of glass, it may break or crack if dropped or bumped on hard surface. Handle with care.
- h) Since CMOS LSI is used in this module, take care of static electricity and take the human earth into consideration when handling.
- i) The module has some printed circuit boards (PCBs) on the back side, take care to keep them from any stress or pressure when handling or installing the module; otherwise some of electronic parts on the PCBs may be damaged.
- j) Observe all other precautionary requirements in handling components.
- k) When some pressure is added onto the module from rear side constantly, it causes display non-uniformity issue, functional defect, etc. So, please avoid such design.
- l) When giving a touch to the panel at power on supply, it may cause some kinds of degradation. In that case, once turn off the power supply, and turn on after several seconds again, and that is disappear.
- m) When handling LCD modules and assembling them into cabinets, please be noted that long-term storage in the environment of oxidization or deoxidization gas and the use of such materials as reagent, solvent, adhesive, resin, etc. which generate these gasses, may cause corrosion and discoloration of the LCD modules.

- n) This LCD module is designed to prevent dust from entering into it. However, there would be a possibility to have a bad effect on display performance in case of having dust inside of LCD module. Therefore, please ensure to design your TV set to keep dust away around LCD module.

11. Packing form

- a) Piling number of cartons : 4 maximum
 b) Packing quantity in one carton : 12 pcs maximum
 c) Carton size : 1140(W) × 1328(D) × 971(H)
 d) Total mass of one carton filled with full modules : 210 kg maximum

[Note] Packing form are shown in Fig.18

12. Reliability test item

No.	Test item	Condition
1	High temperature storage test	Ta=60°C 240h
2	Low temperature storage test	Ta=-25°C 240h
3	High temperature and high humidity operation test	Ta=40°C ; 95%RH 240h (No condensation)
4	High temperature operation test	Ta=50°C 240h
5	Low temperature operation test	Ta=0°C 240h
6	Vibration test (non-operation)	Frequency: 10~57Hz/Vibration width (one side): 0.075mm : 57~500Hz/Acceleration: 9.8 m/s ² Sweep time: 11 minutes Test period: 3 hours (1h for each direction of X, Y, Z)
7	Shock test (non-operation)	Maximum acceleration: 294m/s ² Pulse width: 11ms, sinusoidal half wave Direction: +/-X, +/-Y, +/-Z, once for each direction.
8	ESD	* At the following conditions, it is a thing without incorrect operation and destruction. (1)Non-operation: Contact electric discharge ±10kV Non-contact electric discharge ±20kV (2)Operation Contact electric discharge ±8kV Non-contact electric discharge ±15kV Conditions: 150pF, 330ohm

[Result evaluation criteria]

Under the display quality test condition with normal operation state, there shall be no change, which may affect practical display function.

13. Others

1) Lot No. Label

The label that displays SHARP, product model (LK520D3LB1S), a product number is stuck on the back of the module.

[LK520D3LB1SP,1SK] NSEC PRODUCTION

[LK520D3LB1SZ] SEMEX PRODUCTION

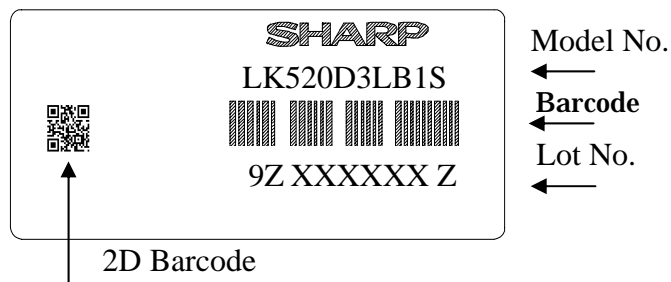
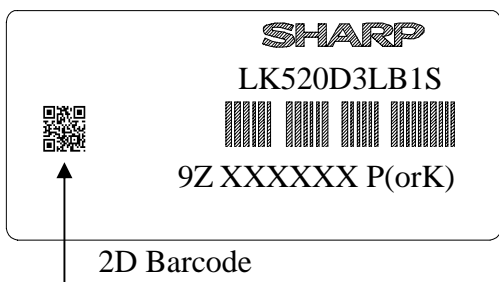

[LK520D3LB1SY] SMPL PRODUCTION

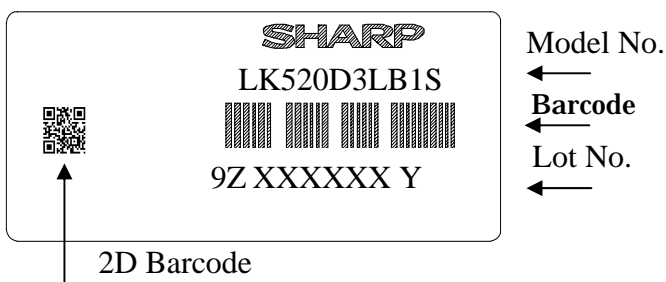

How to express Lot No.

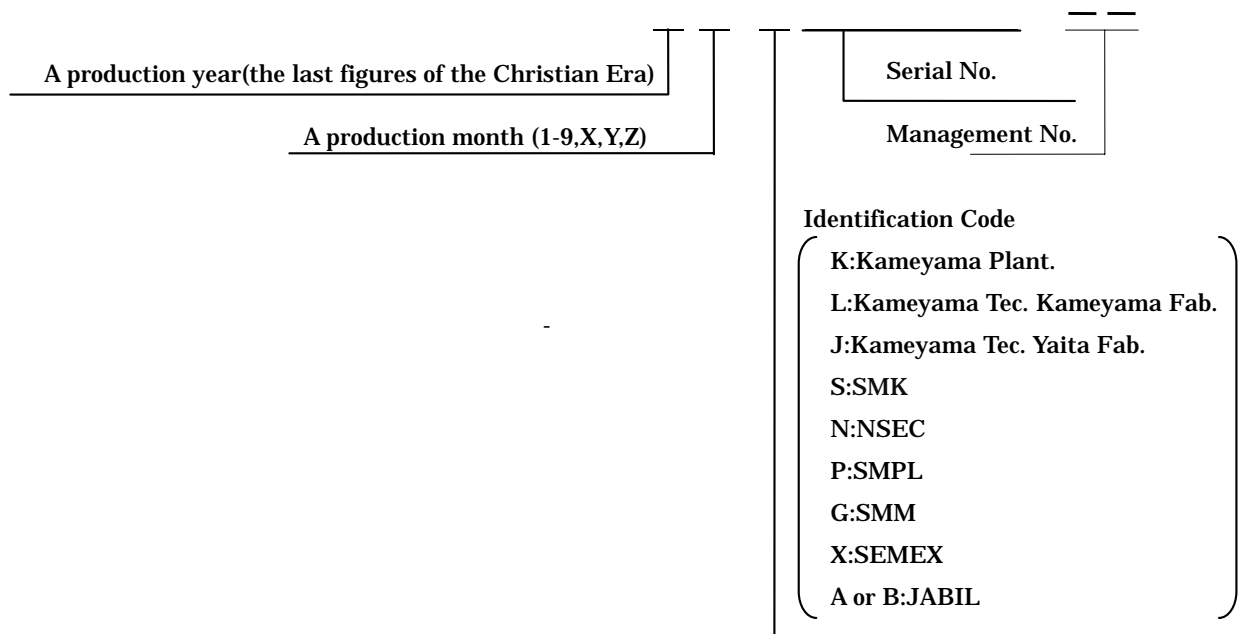

Fig.14 Lot number label description specification

2) Packing Label

[LK520D3LB1SP,1SK] NSEC PRODUCTION

社内品番 (4 S)LK520D3LB1SP(K)()

Bar code

LotNO.(1T) 20**.**.* * * * * ()

Bar code

Quantity (O) 12 pcs ()

Bar code

ユーザ品番 1-811-091-11

Bar code

シャープ物流用ラベルです。

[LK520D3LB1SZ] SEMEX PRODUCTION

MODEL : (4 S)LK520D3LB1SZ ()

Bar code

LotNO.(1T) 20**.**.* * * * * ()

Bar code

Quantity (O) 12 pcs ()

Bar code

ユーザ品番 1-811-091-31

Bar code

シャープ物流用ラベルです。

[LK520D3LB1SY] SMPL PRODUCTION

社内品番 (4 S)LK520D3LB1SY ()

Bar code

LotNO.(1T) 20**.**.* * * * * ()

Bar code

Quantity (O) 12 pcs ()

Bar code

ユーザ品番 1-811-091-21

Bar code

シャープ物流用ラベルです。

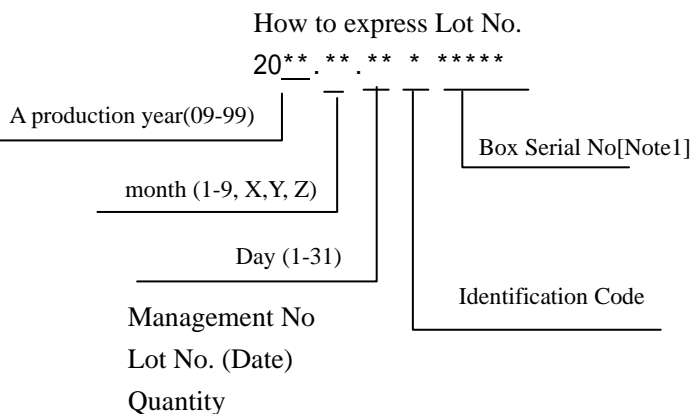

[Note 1] Box Serial Number is nine digits only the JABIL POLAND production, and besides, five digits.

Fig.15 Packing label description specification

3)Material Label

MATERIAL INFORMATION

Reflective Polarizer: > PC , PEST , AKUR - X , PC <

Lens Film: > PC <

Diffuser Sheet: > PET <

Light Guide: > PMMA <

Reflective Sheet: > PET <

Fig.16 Material label description specification

- 4) Adjusting volume has been set optimally before shipment, so do not change any adjusted value.
If adjusted value is changed, the specification may not be satisfied.
- 5) Disassembling the module can cause permanent damage and should be strictly avoided.
- 6) Please be careful since image retention may occur when a fixed pattern is displayed for a long time.
- 7) The chemical compound, which causes the destruction of ozone layer, is not being used.
- 8) When any question or issue occurs, it shall be solved by mutual discussion.
- 9) This module is corresponded to RoHS.

14. Carton storage condition

Temperature	0°C to 40°C
Humidity	95%RH or less
Reference condition	: 20°C to 35°C, 85%RH or less (summer) : 5°C to 15°C, 85%RH or less (winter) • the total storage time (40°C,95%RH) : 240H or less
Sunlight	Be sure to shelter a product from the direct sunlight.
Atmosphere	Harmful gas, such as acid and alkali which bites electronic components and/or wires must not be detected.
Notes	Be sure to put cartons on palette or base, don't put it on floor, and store them with removing from wall Please take care of ventilation in storehouse and around cartons, and control changing temperature is within limits of natural environment
Storage life	1 year

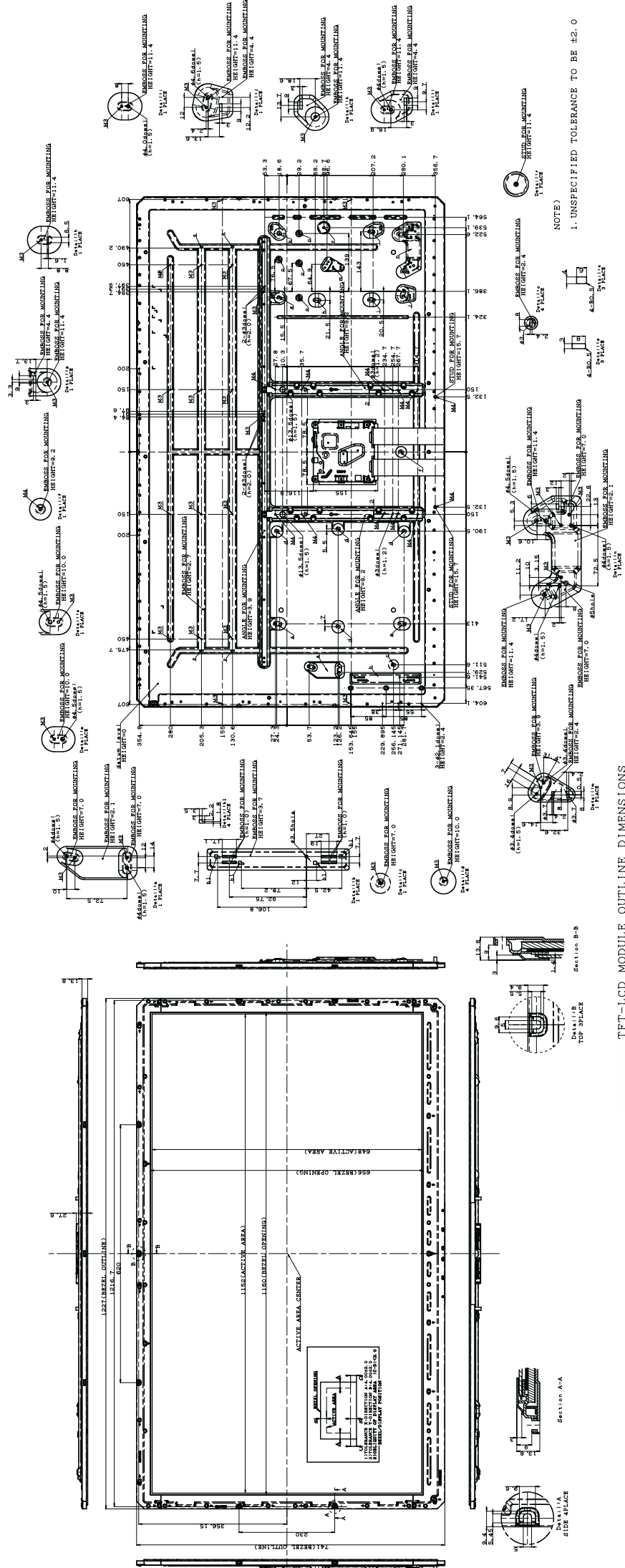

TFT-LCD MODULE OUTLINE DIMENSIONS
Fig.17 LK520D3LB1S

Parts Name	Material
Packing Case(Top)	Cardboard
Pack Ado(Bottom)	PS
Pack Ado(TopA)	PS
Pack Ado(TopB)	PS
Packing Case(Trunk frame)	Cardboard
Cardboard Prop	Cardboard
Plywood Palette	Heat treatment woods
Antistatic Bag	PE(t=20μ)

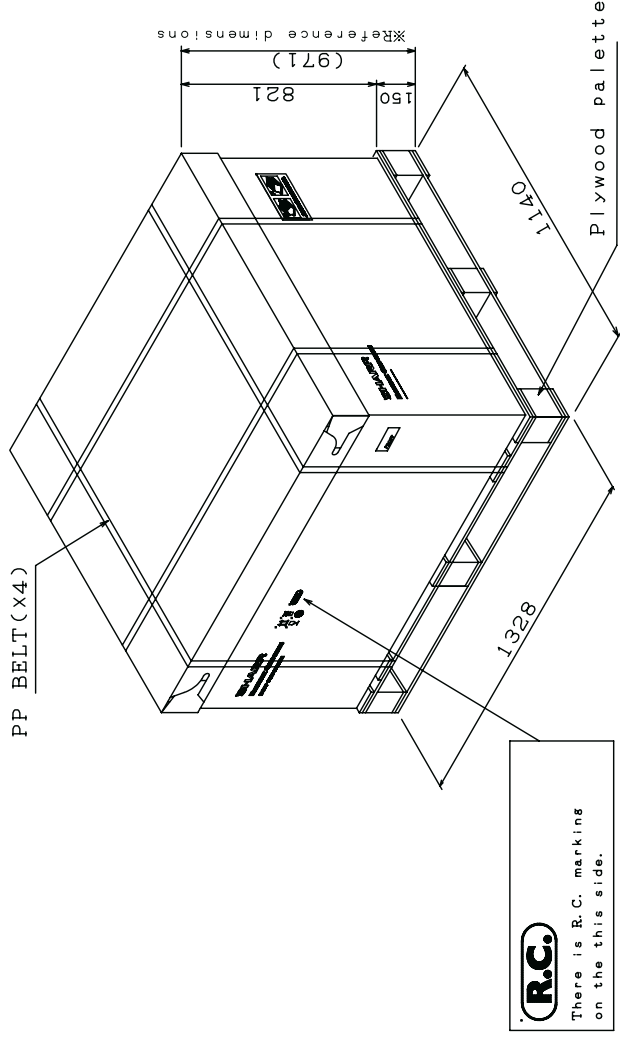
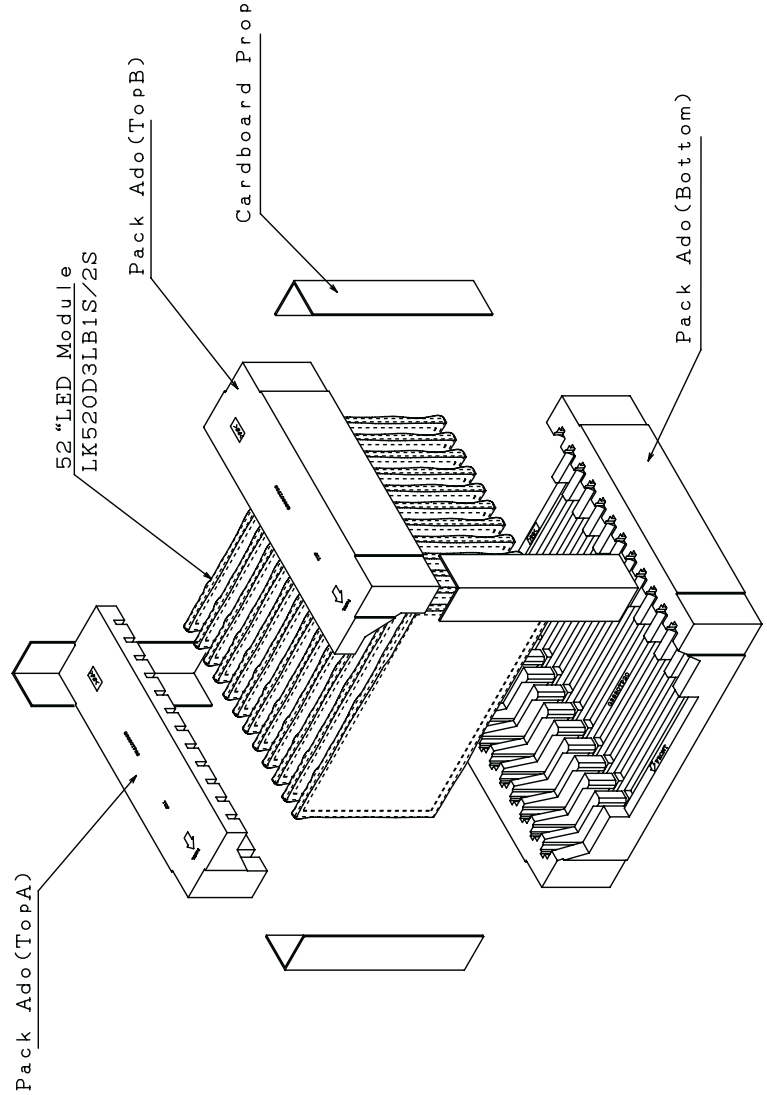
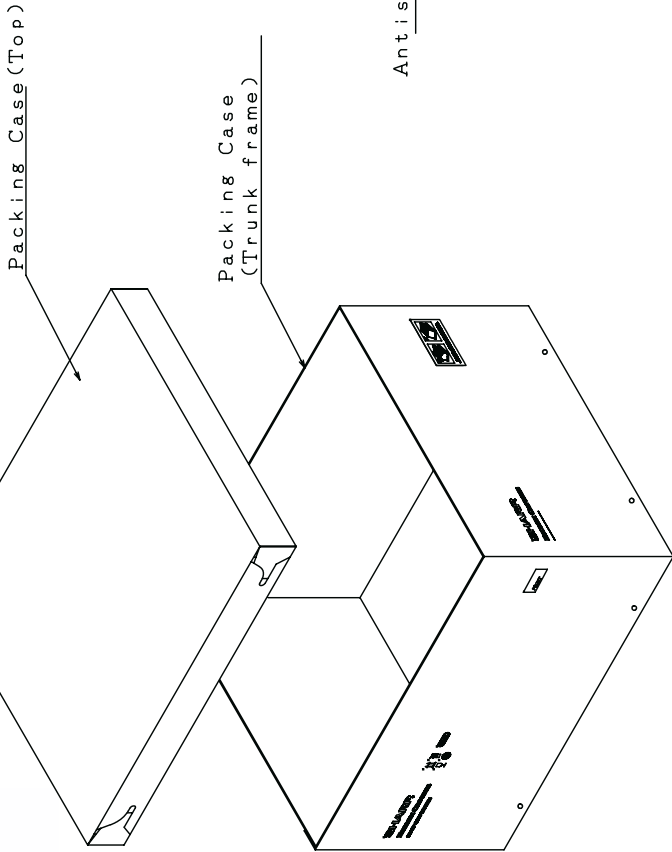
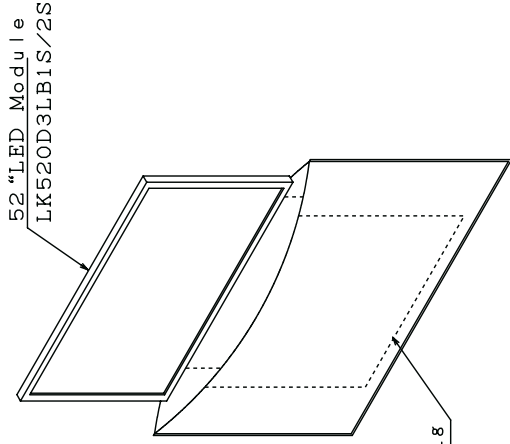

《Architect's Conception》

Fig.18 LK520D3LB1S Packing Form