

PREPARED BY: DATE	SHARP	SPEC.No.: LD-K24304
APPROVED BY: DATE		FILE No.:
		ISSUE: Mar. 7. 2012
	LARGE LIQUID CRYSTAL DISPLAY BUSSINESS GROUP SHARP CORPORATION SPECIFICATION	PAGE: 23 pages
		LIQUID CRYSTAL DISPLAY DIVISION

DEVICE SPECIFICATION FOR

TFT-LCD Module

Model No. LK695D3LA1W

CUSTOMER'S APPROVAL

DATE

PRESENTED

BY _____

BY

Akira Yamaguchi

Akira Yamaguchi

DIVISION DEPUTY GENERAL MANAGER
LIQUID CRYSTAL DISPLAY DIVISION
LARGE LIQUID CRYSTAL BUSSINESS GROUP
SHARP CORPORATION

1. Application

This specification is applied to the color 69.5" TFT-LCD module LK695D3LA1W.

- * This specification is proprietary products of SHARP CORPORATION ("SHARP") and includes materials protected under copyright of SHARP. Do not reproduce or cause any third party to reproduce them in any form or by any means, electronic or mechanical, for any purpose, in whole or in part, without the express written permission of SHARP.
- * In case of using the device for applications such as control and safety equipment for transportation (aircraft, trains, automobiles, etc.), rescue and security equipment and various safety related equipment which require higher reliability and safety, take into consideration that appropriate measures such as fail-safe functions and redundant system design should be taken.
- * Do not use the device for equipment that requires an extreme level of reliability, such as aerospace applications, telecommunication equipment (trunk lines), nuclear power control equipment and medical or other equipment for life support.
- * SHARP assumes no responsibility for any damage resulting from the use of the device that does not comply with the instructions and the precautions specified in these specification.
- * Contact and consult with a SHARP sales representative for any questions about this device.

2. Overview

This module is a color active matrix LCD module incorporating amorphous silicon TFT (Thin Film Transistor). It is composed of a color TFT-LCD panel, driver ICs, control circuit, LED driver circuit, and edge-light LED system etc. Graphics and texts can be displayed on a 1920×RGB×1080 dots panel with 16.7 million colors (RGB 8bits) by using LVDS (Low Voltage Differential Signaling) to interface, +12V of DC supply voltages.

And in order to improve the response time of LCD, this module applies the Over Shoot driving (O/S driving) technology for the control circuit. In the O/S driving technology, signals are being applied to the Liquid Crystal according to a pre-fixed process as an image signal of the present frame when a difference is found between image signal of the previous frame and that of the current frame after comparing them.

With this technology, image signals can be set so that liquid crystal response completes within one frame. As a result, motion blur reduces and clearer display performance can be realized.

This LCD-module can be installed by both installation direction "landscape" and "portrait" based on Section 5.

3. Mechanical Specifications

Parameter	s	Unit	remark
Display size	176.563 (Diagonal)	cm	
	69.513 (Diagonal)	inch	
Active area	1538.880 (H) x 865.620 (V)	mm	[Note2]
Pixel Format	1920(H) x 1080(V) (1pixel = R + G + B dot)	pixel	[Note2]
Pixel pitch	0.802(H) x 0.802 (V)	mm	[Note2]
Pixel configuration	R, G, B vertical stripe		[Note2]
Display mode	Normally black		
Outline Dimensions [Note 1]	1566(W) x 901.8(H) x 29.6(D)	mm	[Note2]
Mass	26.0±1.5	kg	
Surface treatment	Low-Haze Anti Glare Hard coating: 2H and more		

[Note 1] Detail outline is shown in figure "MODULE OUTLINE DIMENSION".

[Note 2] In case of Landscape installation

4. Input Terminals

4.1. TFT panel driving

CN1 (Interface signals and +12V DC power supply)

Using connector : 91213-0510Y (ACES)

Mating connector : 91214-05130 (ACES), FI-RNE51HL/FI-RNE51CL(JAE)

Mating LVDS transmitter : THC63LVD1023 or equivalent device

Pin No.	Symbol	Function	Remark
1	GND	(It is not necessary to connect.)	
2	Reserved	It is required to set non-connection(OPEN)	
3	Reserved	It is required to set non-connection(OPEN)	
4	Reserved	It is required to set non-connection(OPEN)	
5	Reserved	It is required to set non-connection(OPEN)	
6	Reserved	It is required to set non-connection(OPEN)	
7	Reserved	It is required to set non-connection(OPEN)	
8	Reserved	It is required to set non-connection(OPEN)	
9	Reserved	It is required to set non-connection(OPEN)	
10	Reserved	It is required to set non-connection(OPEN)	
11	GND	(It is not necessary to connect.)	
12	Reserved	It is required to set non-connection(OPEN)	
13	Reserved	It is required to set non-connection(OPEN)	
14	Reserved	It is required to set non-connection(OPEN)	
15	Reserved	It is required to set non-connection(OPEN)	
16	Reserved	It is required to set non-connection(OPEN)	
17	Reserved	It is required to set non-connection(OPEN)	
18	GND	(It is not necessary to connect.)	
19	Reserved	It is required to set non-connection(OPEN)	
20	Reserved	It is required to set non-connection(OPEN)	
21	GND	(It is not necessary to connect.)	
22	Reserved	It is required to set non-connection(OPEN)	
23	Reserved	It is required to set non-connection(OPEN)	
24	Reserved	It is required to set non-connection(OPEN)	
25	Reserved	It is required to set non-connection(OPEN)	
26	GND	(It is not necessary to connect.)	
27	GND	(It is not necessary to connect.)	
28	Reserved	It is required to set non-connection(OPEN)	
29	Reserved	It is required to set non-connection(OPEN)	
30	Reserved	It is required to set non-connection(OPEN)	
31	Reserved	It is required to set non-connection(OPEN)	
32	Reserved	It is required to set non-connection(OPEN)	
33	Reserved	It is required to set non-connection(OPEN)	
34	GND	(It is not necessary to connect.)	
35	Reserved	It is required to set non-connection(OPEN)	
36	Reserved	It is required to set non-connection(OPEN)	
37	GND	(It is not necessary to connect.)	
38	Reserved	It is required to set non-connection(OPEN)	
39	Reserved	It is required to set non-connection(OPEN)	
40	Reserved	It is required to set non-connection(OPEN)	
41	Reserved	It is required to set non-connection(OPEN)	
42	GND		
43	GND		
44	GND		
45	GND		
46	GND		
47	VCC	+12V Power Supply	
48	VCC	+12V Power Supply	
49	VCC	+12V Power Supply	
50	VCC	+12V Power Supply	
51	VCC	+12V Power Supply	

CN2 (Interface signals and +12V DC power supply)

Using connector : 91213-0410Y (ACES)

Mating connector : 91214-04130 (ACES), FI-RNE41HL/FI-RNE41CL(JAE)

Pin No.	Symbol	Function	Remark
1	N.C	Non connection	
2	N.C	Non connection	
3	N.C	Non connection	
4	N.C	Non connection	
5	Reserved		
6	Reserved		
7	Reserved		
8	Reserved		
9	GND		
10	AIN0-	Aport (-)LVDS CH0 differential data input	
11	AIN0+	Aport (+)LVDS CH0 differential data input	
12	AIN1-	Aport (-)LVDS CH1 differential data input	
13	AIN1+	Aport (+)LVDS CH1 differential data input	
14	AIN2-	Aport (-)LVDS CH2 differential data input	
15	AIN2+	Aport (+)LVDS CH2 differential data input	
16	GND		
17	ACK-	Aport LVDS Clock signal(-)	
18	ACK+	Aport LVDS Clock signal(+)	
19	GND		
20	AIN3-	Aport (-)LVDS CH3 differential data input	
21	AIN3+	Aport (+)LVDS CH3 differential data input	
22	GND		
23	GND		
24	GND		
25	GND		
26	BIN0-	Bport (-)LVDS CH0 differential data input	
27	BIN0+	Bport (+)LVDS CH0 differential data input	
28	BIN1-	Bport (-)LVDS CH1 differential data input	
29	BIN1+	Bport (+)LVDS CH1 differential data input	
30	BIN2-	Bport (-)LVDS CH2 differential data input	
31	BIN2+	Bport (+)LVDS CH2 differential data input	
32	GND		
33	BCK-	Bport LVDS Clock signal(-)	
34	BCK+	Bport LVDS Clock signal(+)	
35	GND		
36	BIN3-	Bport (-)LVDS CH3 differential data input	
37	BIN3+	Bport (+)LVDS CH3 differential data input	
38	GND		
39	GND		
40	GND		
41	GND		

[Note1] GND of a liquid crystal panel drive part has connected with a module chassis.

LVDS Data order

Data	[JEIDA]
TA0	R2
TA1	R3
TA2	R4
TA3	R5
TA4	R6
TA5	R7(MSB)
TA6	G2
TB0	G3
TB1	G4
TB2	G5
TB3	G6
TB4	G7(MSB)
TB5	B2
TB6	B3
TC0	B4
TC1	B5
TC2	B6
TC3	B7(MSB)
TC4	NA
TC5	NA
TC6	DE(*)
TD0	R0
TD1	R1
TD2	G0
TD3	G1
TD4	B0
TD5	B1
TD6	N/A

NA: Not Available

(*)Since the display position is prescribed by the rise of DE(Display Enable)signal, please do not fix DE signal at "High" during operation.

LVDS = JEIDA only

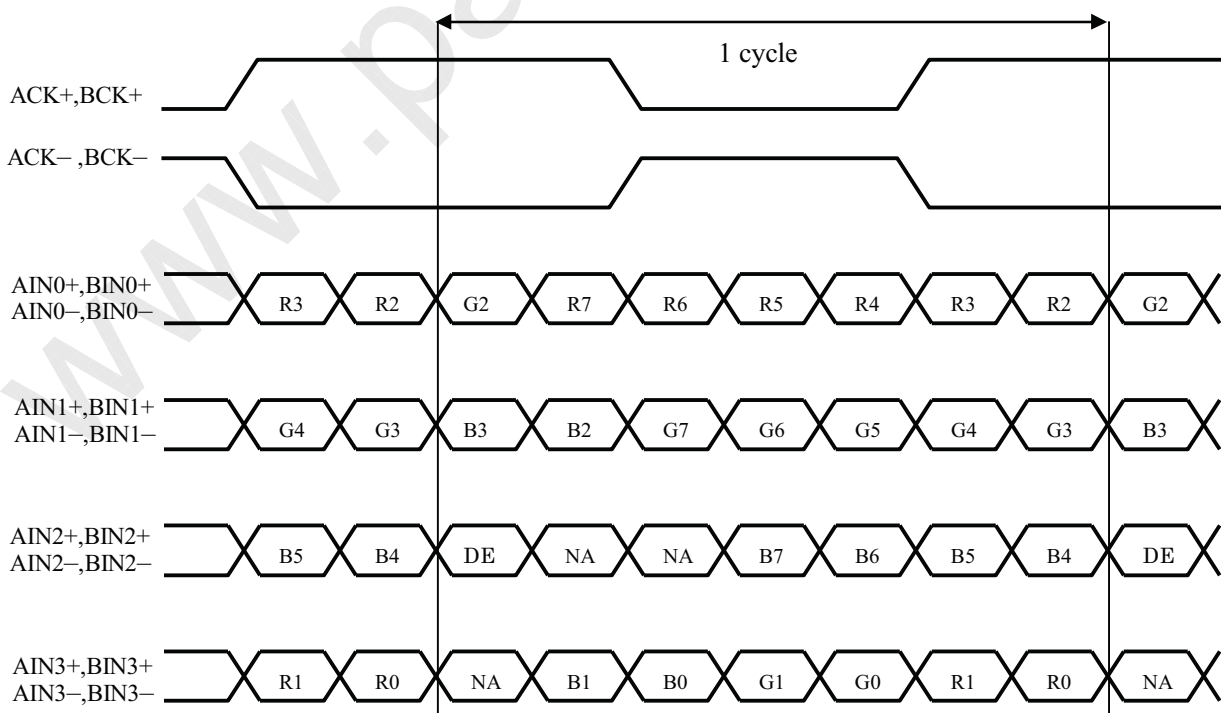

DE: Display Enable, NA: Not Available (Fixed Low)

4.2. Interface block diagram

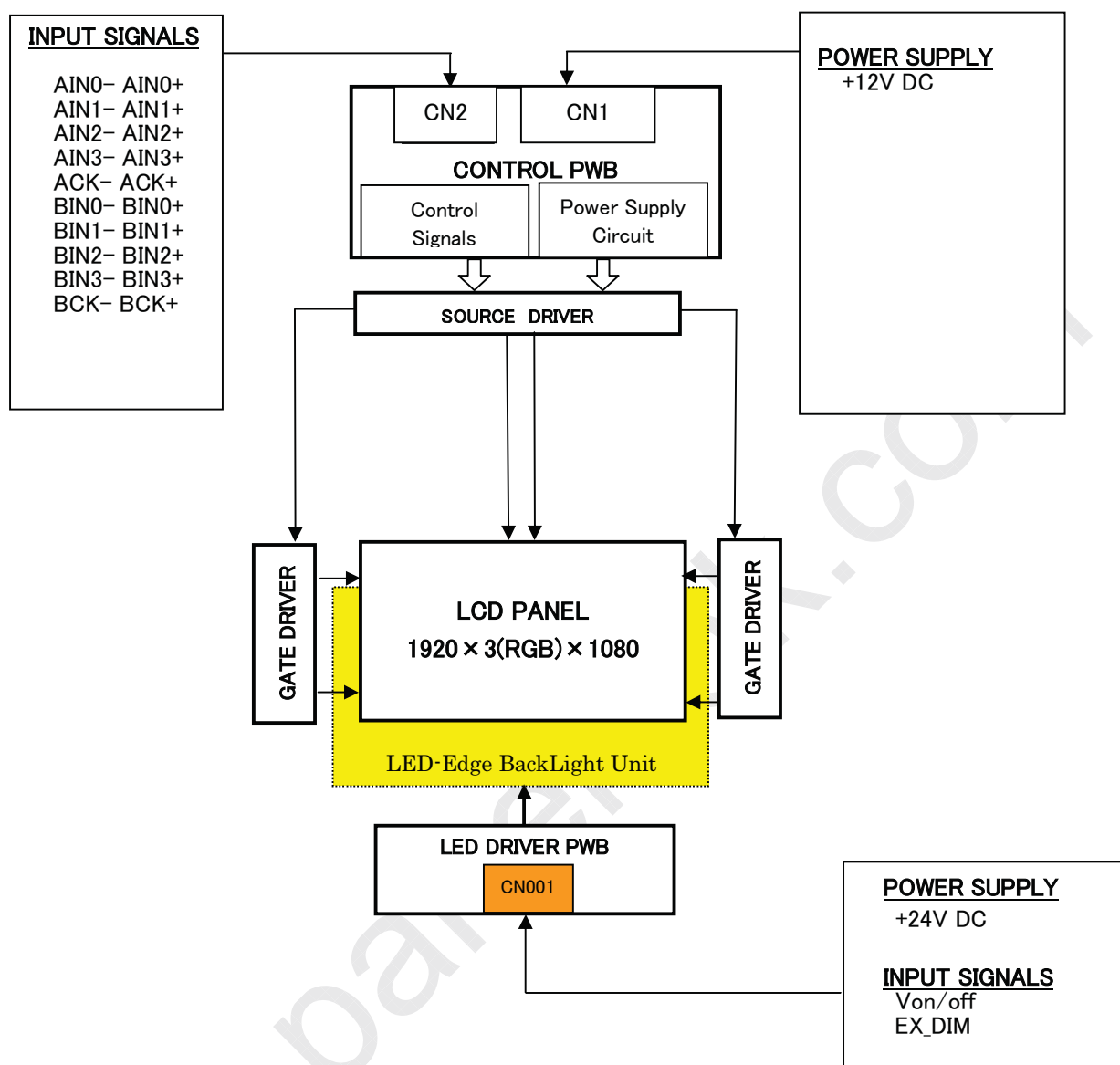

4.3. Backlight driving

CN001 (+24V DC power supply and inverter control)

Using connector: 20022WR-14B1(YEONHO)

Mating connector: 20022HS-14L (YEONHO) or equivalent connector.

Pin No.	Symbol	I/O	Function	Default(OPEN)	Input Impedance (min)	Remark
1	VLED	In	+24V	-		
2	VLED	In	+24V	-		
3	VLED	In	+24V	-		
4	VLED	In	+24V	-		
5	VLED	In	+24V	-		
6	GND	In	GND	-		
7	GND	In	GND	-		
8	GND	In	GND	-		
9	GND	In	GND	-		
10	GND	In	GND	-		
11	Error_out	Out	Error Detection	Open Collector		[Note 1]
12	Von/off	In	LED driver On/Off	LED driver Off	10k-ohm pull-down to GND	[Note 2]
13	NC	-	-	-	-	-
14	EX_DIM	In	Brightness Control (PWM 1~100%)	3.3V : pull up Brightness 100%	10k-ohm pull-up to 3.3V	[Note 3] Pulse Dimming

[Note 1] Error Detection

	MIN	TYP	MAX
Normal	-	-	0.8V
Abnormal	Open Collector		

[Note 2] LED driver ON/OFF

Input voltage	Symbol	Voltage	Function
High voltage	V _{ON}	2.4~3.6V	LED driver : On
Low voltage	V _{OFF}	-0.3~0.8V	LED driver : Off

[Note 3] Pulse Dimming

Pin No.14 'EX_DIM' is used for the pulse dimming control by the PWM duty with input pulse from 90Hz to 360Hz.

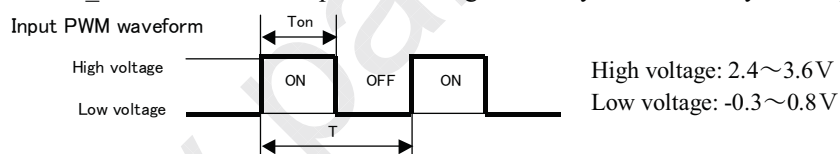

		MIN	TYP	MAX	Remark
Pulse signal	[Hz]	90	-	360	
DUTY(Ton/T)	[%]	1	-	100	Ta=25°C
Dimming level (luminance ratio)	[%]	-	-	100	Ta=25°C

5. Installation and Display direction

5.1 Installation direction

This module can be installed by both installation direction “landscape” and “portrait” as follows.

[Landscape direction]

In front view, CPWB is located BOTTOM

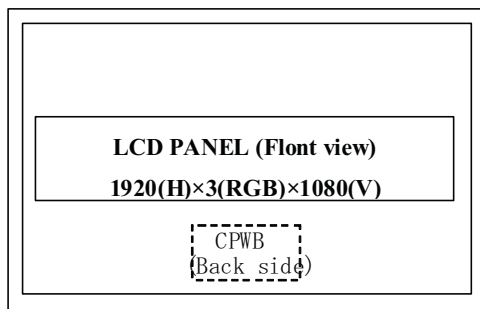

[Portrait direction]

In front view, CPWB is located Left-side

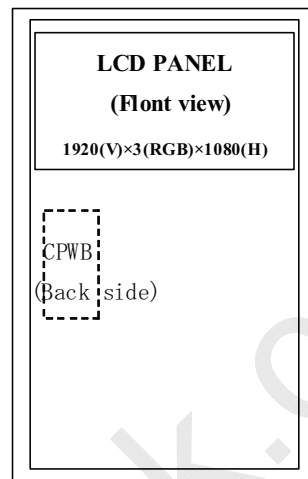

[Note] Other installation direction

Since the other installation direction cannot be guaranteed the characteristic and reliability, **NOT recommended.**

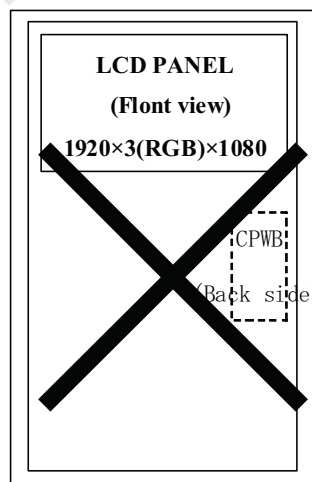
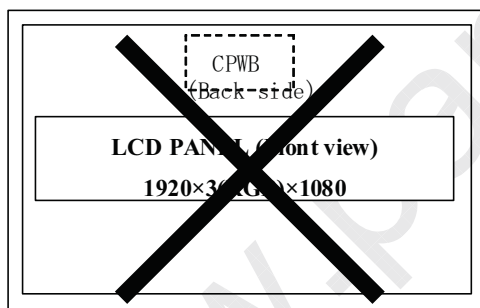

5.2 Display direction

Each subpixel R, G, B is aligned as follows.

[Landscape direction]

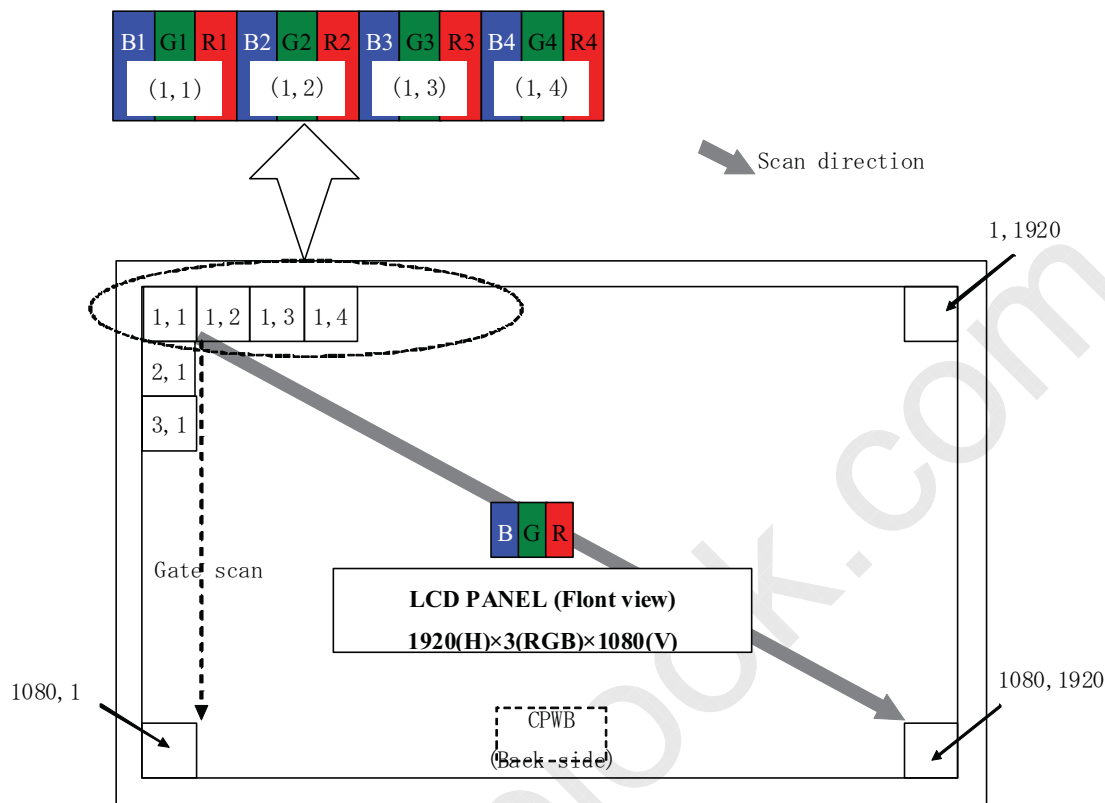

LCD subpixel alignment in Landscape installaion

[Note] PWB layout

In Landscape installation,

Four S-PWBs and three LED-PWBs are layout at the bottom side of the screen.

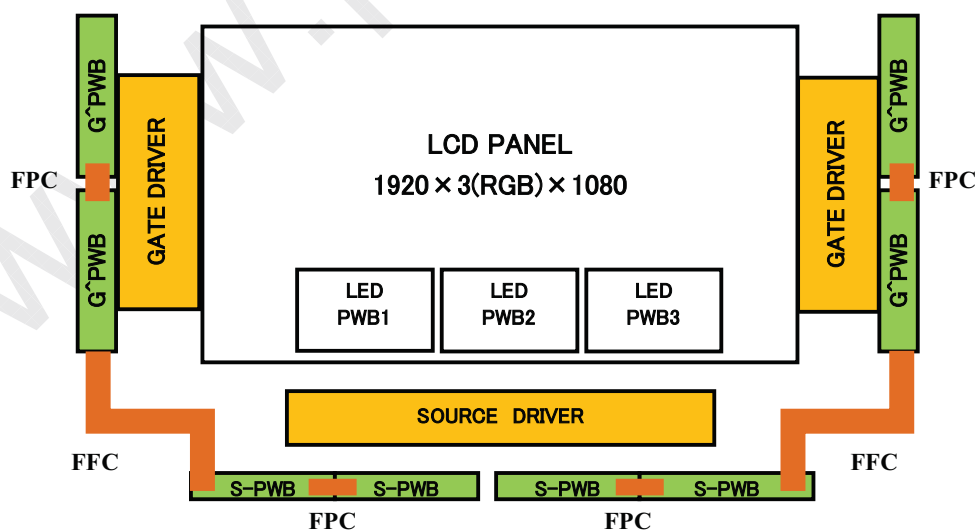

Layout of LED-PWB, S-PWB & G-PWB (Front View)

[Portrait direction]

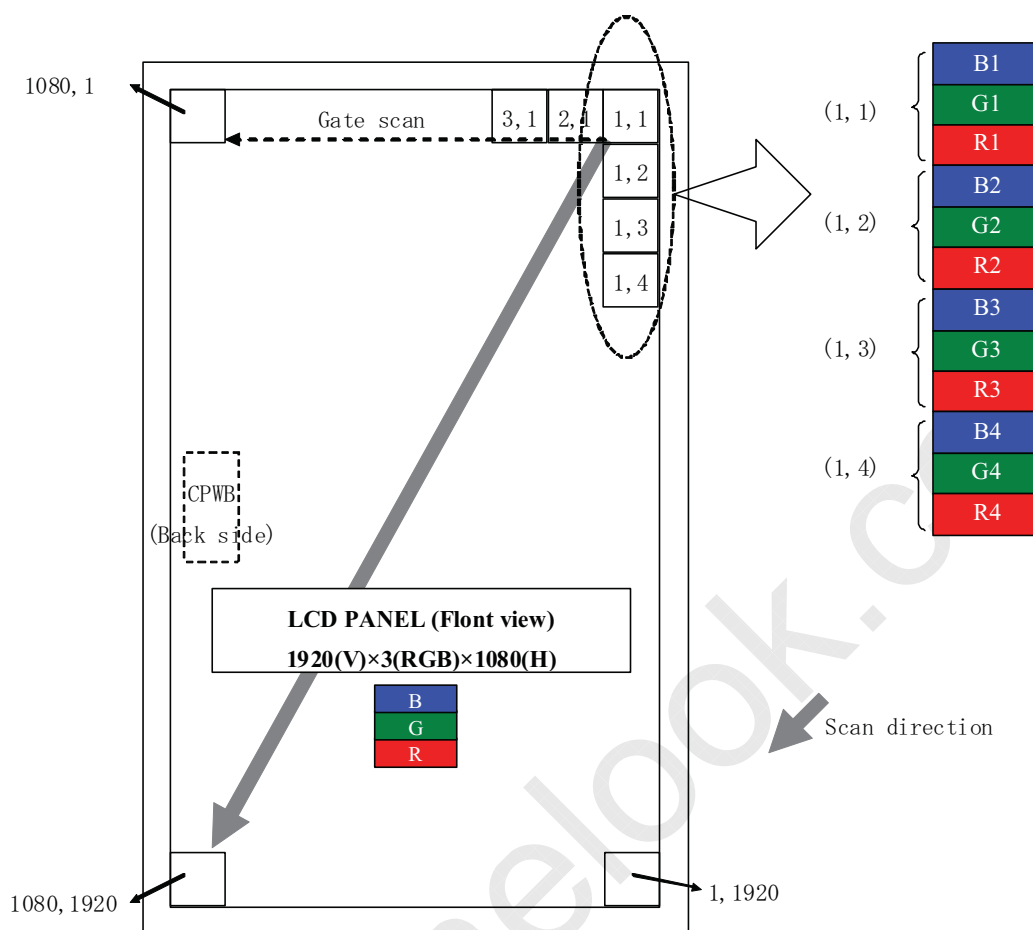

LCD subpixel alignment in Portrait installaion

5. Absolute Maximum Ratings

Parameter	Symbol	Condition	Ratings	Unit	Remark
12V supply voltage (for Control PWB)	VCC	Ta=25 °C	0 ~ +14	V	
24V supply voltage (for LED Driver)	V _{LED}	Ta=25 °C	0 ~ +29.0	V	
Input voltage (for LED Driver)	V _{on} /V _{off} V _{DIMH} /V _{DIML}	Ta=25 °C	-0.3 ~ +3.9	V	[Note 1]
Storage temperature	Tstg	-	-25 ~ +60	°C	[Note 2]
Operation temperature (Ambient)	Topa	-	0 ~ +50	°C	

[Note 1] Von/off, EX_DIM in CN001.

[Note 2] Humidity 95%RH Max. (Ta ≤ 40°C)

Maximum wet-bulb temperature at 39 °C or less.(Ta > 40°C). No condensation.

6. Electrical Characteristics

6.1. Control circuit driving

Ta=25 °C

Parameter		Symbol	Min.	Typ.	Max.	Unit	Remark
+12V supply voltage	Supply voltage	V _{CC}	11.4	12	12.6	V	[Note 1]
	Current dissipation	I _{CC}	-	0.75	2.0	A	[Note 2]
	Inrush current	I _{RUSH1}	-	4.4	-	A	t ₁ =500us [Note3]
		I _{RUSH2}	-	2.4	-	A	t ₁ >5ms
Permissible input ripple voltage		V _{RP}	-	-	100	mV _{P-P}	V _{CC} = +12.0V
Differential input threshold voltage	High	V _{TH}	-	-	100	mV	V _{CM} = +1.2V [Note 4]
	Low	V _{TL}	-100	-	-	mV	
Terminal resistor		R _T	-	100	-	Ω	Differential input

[Note]V_{CM}: Common mode voltage of LVDS driver.

[Note 1]

Input voltage sequences

$$50\mu\text{s} < t_1 \leq 20\text{ms}$$

$$20\text{ms} < t_2 \leq 5\text{s}$$

$$0 < t_3 \leq 1\text{s}$$

$$0 < t_4 \leq 1\text{s}$$

$$1\text{s} \leq t_5$$

$$0 \leq t_6$$

Dip conditions for supply voltage

$$\text{a) } 9.1\text{V} \leq V_{CC} < 10.8\text{V}$$

$$t_d \leq 10\text{ms}$$

$$\text{b) } V_{CC} < 9.1\text{V}$$

Dip conditions for supply voltage is based on input voltage sequence.

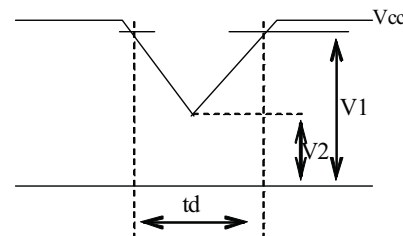
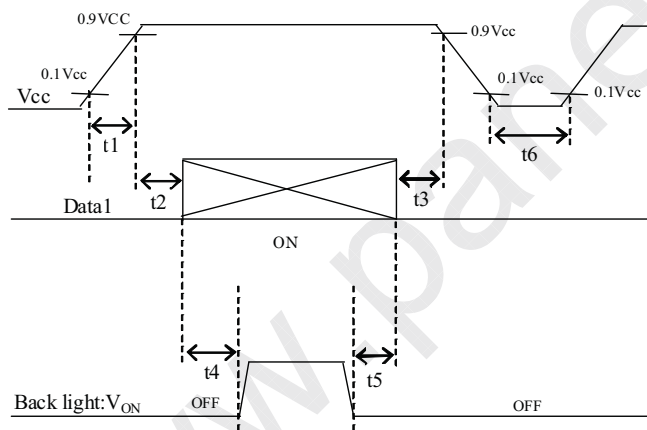

V1:10.8V
V2:9.1V

※ Data1: ACK±, AIN0±, AIN1±, AIN2±, AIN3±, BCK±, BIN0±, BIN1±, BIN2±, BIN3±

*V_{CM} voltage pursues the sequence mentioned above

[Note]About the relation between data input and back light lighting, please base on the above-mentioned input sequence. When back light is switched on before panel operation or after a panel operation stop, it may not display normally. But this phenomenon is not based on change of an incoming signal, and does not give damage to a liquid crystal display.

[Note 2] Typical current situation: 1024 gray-bar patterns. $V_{CC} = +12.0V$

The explanation of RGB gray scale is seen in section 8.

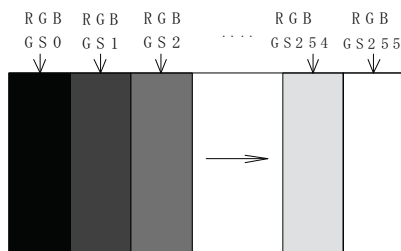

$V_{CC} = +12.0V$
 $CK = 74.25MHz$
 $Th = 14.8\mu s$

[Note 3] V_{CC} 12V inrush current waveform (I_{RUSH1})

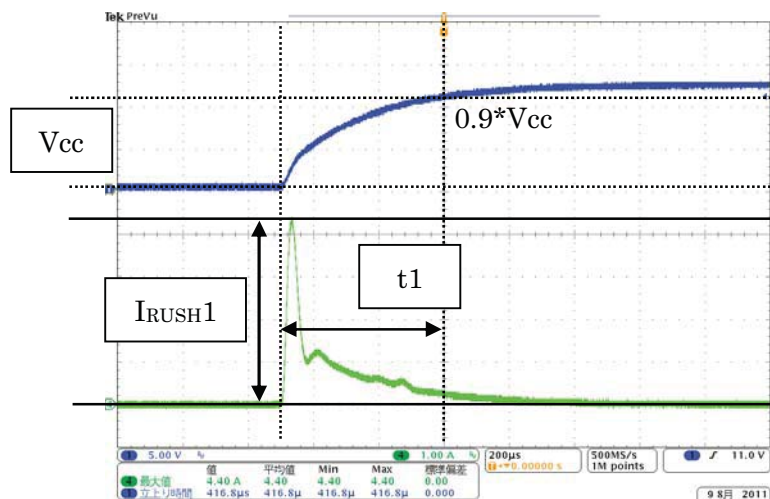

[Note 4] $ACK\pm$, $AIN0\pm$, $AIN1\pm$, $AIN2\pm$, $AIN3\pm$, $BCK\pm$, $BIN0\pm$, $BIN1\pm$, $BIN2\pm$, $BIN3\pm$



6.2. LED driving for Back Light

Ta=25 °C

Parameter		Symbol	Min.	Typ.	Max.	Unit	Remark
+24V supply voltage	Current dissipation	I _{LEDD}	-	7.8	8.6	A	V _{LED} = 24V, Ta=25°C DUTY =100% [Note 1]
	Irush current	I _{RUSH}	-	22.0	24.0	A	
	Supply voltage	V _{LED}	21.6	24.0	26.4	V	24V±10%
Permissible input ripple voltage		V _{RP}	-	-	1	V _{P-P}	V _{LEDD} =+24.0V
Input voltage (On)		V _{ON}	2.4	3.0	3.6	V	V _{ON/OFF} , EX_DIM
Input voltage (Off)		V _{OFF}	-0.3	0	0.8	V	

[Note 1] 1) V_{LED}-turn-on condition

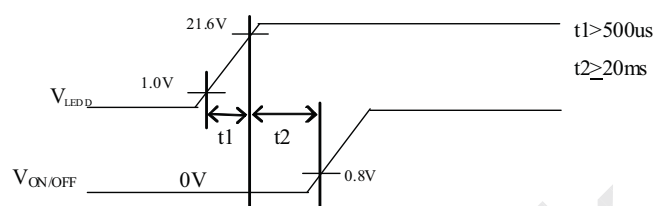

2) V_{LED}-turn-off condition

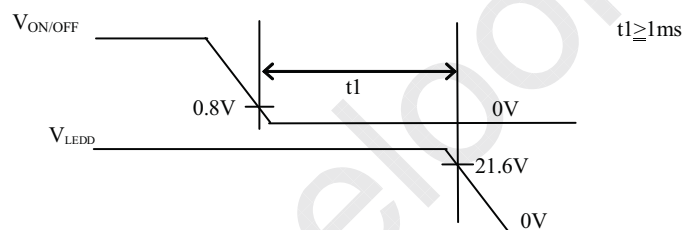

6.3 LED lifetime

LED light system is side-edge type. The characteristics of the LED are shown in the following table. The value mentioned below is at the case of one LED.

Item	Symbol	Min.	Typ.	Max.	Unit	Remarks
Life time	T _{LED}	-	50.000	-	Hour	[Note]

[Note]

LED life time is defined as the time when brightness becomes 50% of the original value in the continuous operation under the condition of Ta = 25°C

[Operation condition]

- ambient temperature Ta=25°C

7 Timing characteristics of input signals

7.1. Timing characteristics

Timing diagrams of input signal are shown in Fig.2.

Parameter	Symbol	Min.	Typ.		Max.	Unit	Remark
			50Hz	60Hz			
Clock	Frequency	1/Tc	60	74.25	74.25	76	MHz
Data enable signal	Horizontal period	TH	1050	1100	1100	1404	Clock
			14.2	14.8	14.8	18.9	μs
	Horizontal period (High)	THd	960	960	960	960	Clock
	Vertical period	TV	1109	1350	1125	1436	Line
47			50	60	63	Hz	
Vertical period (High)	TVd	1080	1080	1080	1080	line	

[Note]-When vertical period is very long, flicker and etc. may occur.

-Please turn off the module after it shows the black screen.

-Please make sure that length of vertical period should become of an integral multiple of horizontal length of period. Otherwise, the screen may not display properly.

-As for your final setting of driving timing, we will conduct operation check test at our side, please inform your final setting.

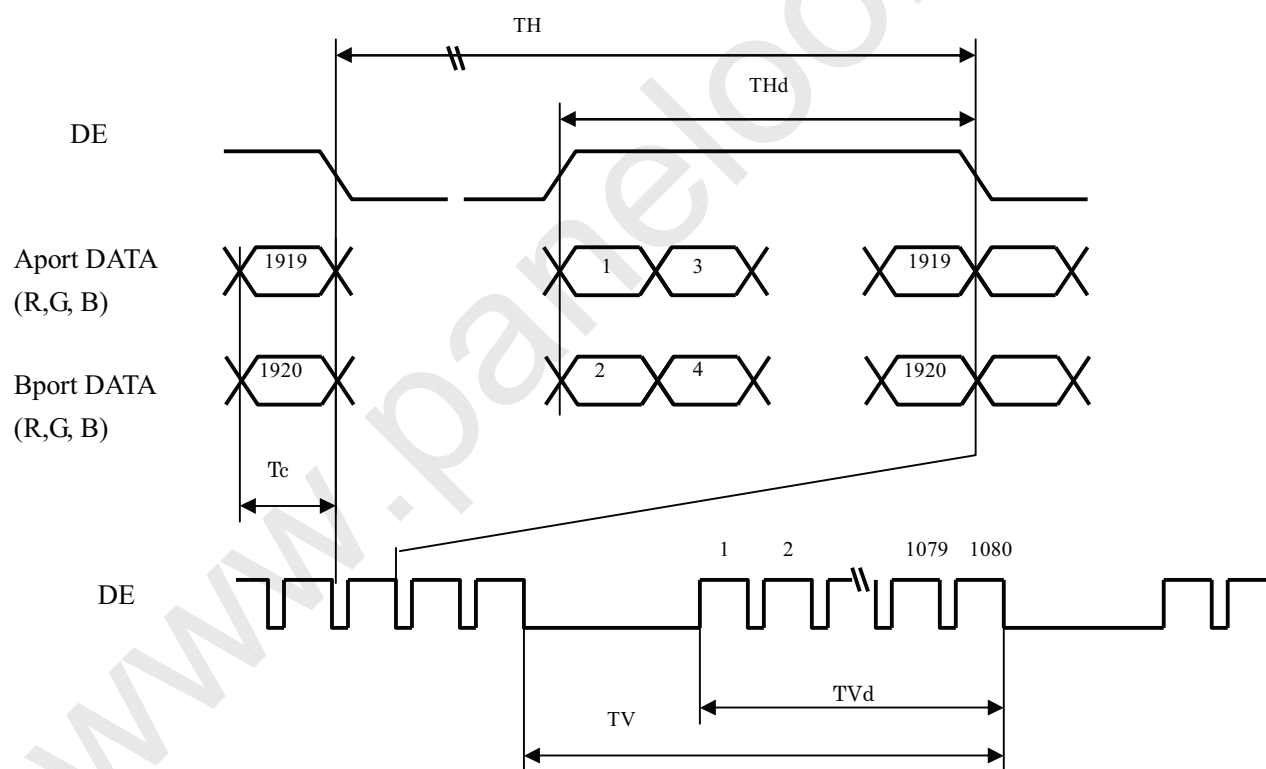
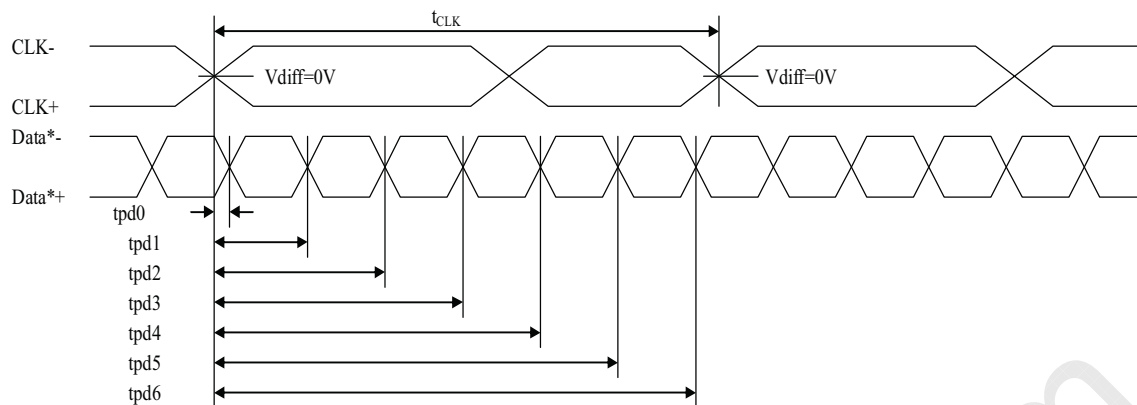

Fig.2 Timing characteristics of input signals

7.2. LVDS signal characteristics



Item	Symbol	Min.	Typ.	Max.	Unit	
Data position	Delay time, CLK rising edge to serial bit position 0	tpd0	-0.25	0	0.25	ns
	Delay time, CLK rising edge to serial bit position 1	tpd1	$1 * t_{CLK} / 7 - 0.25$	$1 * t_{CLK} / 7$	$1 * t_{CLK} / 7 + 0.25$	
	Delay time, CLK rising edge to serial bit position 2	tpd2	$2 * t_{CLK} / 7 - 0.25$	$2 * t_{CLK} / 7$	$2 * t_{CLK} / 7 + 0.25$	
	Delay time, CLK rising edge to serial bit position 3	tpd3	$3 * t_{CLK} / 7 - 0.25$	$3 * t_{CLK} / 7$	$3 * t_{CLK} / 7 + 0.25$	
	Delay time, CLK rising edge to serial bit position 4	tpd4	$4 * t_{CLK} / 7 - 0.25$	$4 * t_{CLK} / 7$	$4 * t_{CLK} / 7 + 0.25$	
	Delay time, CLK rising edge to serial bit position 5	tpd5	$5 * t_{CLK} / 7 - 0.25$	$5 * t_{CLK} / 7$	$5 * t_{CLK} / 7 + 0.25$	
	Delay time, CLK rising edge to serial bit position 6	tpd6	$6 * t_{CLK} / 7 - 0.25$	$6 * t_{CLK} / 7$	$6 * t_{CLK} / 7 + 0.25$	

8 Input Signal, Basic Display Colors and Gray Scale of Each Color

	Colors &	Data signal																								
	Gray scale	Gray	R0	R1	R2	R3	R4	R5	R6	R7	G0	G1	G2	G3	G4	G5	G6	G7	B0	B1	B2	B3	B4	B5	B6	B7
Basic Color	Black	-	0	0	0	0	0	0	0	0	0	0	0	0	0	0	0	0	0	0	0	0	0	0	0	0
	Blue	-	0	0	0	0	0	0	0	0	0	0	0	0	0	0	0	0	1	1	1	1	1	1	1	1
	Green	-	0	0	0	0	0	0	0	0	1	1	1	1	1	1	1	1	0	0	0	0	0	0	0	0
	Cyan	-	0	0	0	0	0	0	0	0	1	1	1	1	1	1	1	1	1	1	1	1	1	1	1	1
	Red	-	1	1	1	1	1	1	1	1	0	0	0	0	0	0	0	0	0	0	0	0	0	0	0	0
	Magenta	-	1	1	1	1	1	1	1	1	0	0	0	0	0	0	0	0	1	1	1	1	1	1	1	1
	Yellow	-	1	1	1	1	1	1	1	1	1	1	1	1	1	1	1	1	0	0	0	0	0	0	0	0
	White	-	1	1	1	1	1	1	1	1	1	1	1	1	1	1	1	1	1	1	1	1	1	1	1	1
Gray Scale of Red	Black	GS0	0	0	0	0	0	0	0	0	0	0	0	0	0	0	0	0	0	0	0	0	0	0	0	
	↑	GS1	1	0	0	0	0	0	0	0	0	0	0	0	0	0	0	0	0	0	0	0	0	0	0	
	Darker	GS2	0	1	0	0	0	0	0	0	0	0	0	0	0	0	0	0	0	0	0	0	0	0	0	
	↑	↓					↓					↓									↓					
	↓	↓					↓					↓									↓					
	Brighter	GS253	1	0	1	1	1	1	1	0	0	0	0	0	0	0	0	0	0	0	0	0	0	0	0	
	↓	GS254	0	1	1	1	1	1	1	0	0	0	0	0	0	0	0	0	0	0	0	0	0	0	0	
	Red	GS255	1	1	1	1	1	1	1	0	0	0	0	0	0	0	0	0	0	0	0	0	0	0	0	
Gray Scale of Green	Black	GS0	0	0	0	0	0	0	0	0	0	0	0	0	0	0	0	0	0	0	0	0	0	0	0	
	↑	GS1	0	0	0	0	0	0	0	1	0	0	0	0	0	0	0	0	0	0	0	0	0	0	0	
	Darker	GS2	0	0	0	0	0	0	0	0	1	0	0	0	0	0	0	0	0	0	0	0	0	0	0	
	↑	↓					↓					↓									↓					
	↓	↓					↓					↓									↓					
	Brighter	GS253	0	0	0	0	0	0	0	1	0	1	1	1	1	1	1	0	0	0	0	0	0	0	0	
	↓	GS254	0	0	0	0	0	0	0	0	1	1	1	1	1	1	1	0	0	0	0	0	0	0	0	
	Green	GS255	0	0	0	0	0	0	0	1	1	1	1	1	1	1	1	0	0	0	0	0	0	0	0	
Gray Scale of Blue	Black	GS0	0	0	0	0	0	0	0	0	0	0	0	0	0	0	0	0	0	0	0	0	0	0	0	
	↑	GS1	0	0	0	0	0	0	0	0	0	0	0	0	0	0	0	1	0	0	0	0	0	0	0	
	Darker	GS2	0	0	0	0	0	0	0	0	0	0	0	0	0	0	0	0	1	0	0	0	0	0	0	
	↓	↓					↓					↓									↓					
	↓	↓					↓					↓									↓					
	Brighter	GS253	0	0	0	0	0	0	0	0	0	0	0	0	0	0	0	1	0	1	1	1	1	1	1	
	↓	GS254	0	0	0	0	0	0	0	0	0	0	0	0	0	0	0	0	1	1	1	1	1	1	1	
	Blue	GS255	0	0	0	0	0	0	0	0	0	0	0	0	0	0	0	1	1	1	1	1	1	1	1	

0: Low level voltage, 1: High level voltage.

Each basic color can be displayed in 256 gray scales from 8 bits data signals. According to the combination of total 24 bits data signals, 16.7 million-color display can be achieved on the screen.

9 Optical characteristics

$T_a=25^{\circ}\text{C}$, $V_{CC}=12.0\text{V}$, $V_{LED}=24.0\text{V}$

Frame rate:60Hz (typical)

Parameter		Symbol	Condition	Min.	Typ.	Max.	Unit	Remark
Viewing angle range	Horizontal	θ_{21} θ_{22}	$CR \geq 10$	70	88	-	Deg.	[Note1,4]
	Vertical	θ_{11} θ_{12}		70	88	-	Deg.	
Contrast ratio		CRn		4000	5000	-	-	[Note2,4]
Response time		τ_{DRV}		-	6	-	ms	$T_a=35^{\circ}\text{C}$ [Note3,4,5]
				-	8	-		$T_a=25^{\circ}\text{C}$ [Note3,4,5]
Chromaticity	White	x	$\theta=0 \text{ deg.}$	0.287	0.317	0.347	-	[Note4]
		y		0.299	0.329	0.359	-	
	Red	x		0.617	0.647	0.677	-	
		y		0.317	0.347	0.377	-	
	Green	x		0.288	0.318	0.348	-	
		y		0.616	0.646	0.676	-	
	Blue	x		0.127	0.157	0.187	-	
		y		0.030	0.060	0.090	-	
Luminance	White	Y_L		400	500	-	cd/m^2	
Luminance uniformity	White	δw		-	1.33	-	-	[Note 6]

- Measurement condition: Set the value of backlight control voltage to maximum luminance of white.
- The measurement shall be executed 60 minutes after lighting at rating.

[Note]The optical characteristics are measured by following equipment:

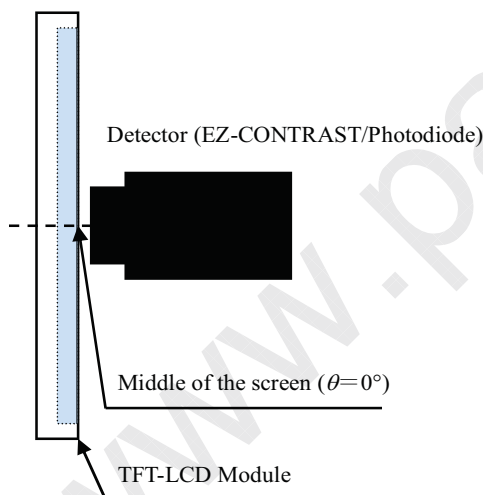

*Measurement of viewing angle range and Response time.

- Viewing angle range: EZ-CONTRAST
- Response time: Photodiode

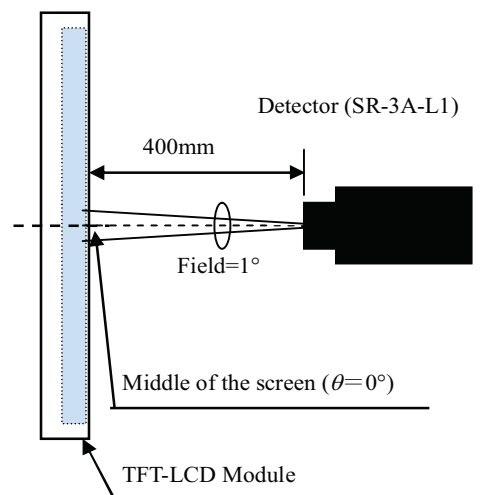

*Measurement of Contrast, Luminance, Chromaticity.

[Note 1] Definitions of viewing angle range:

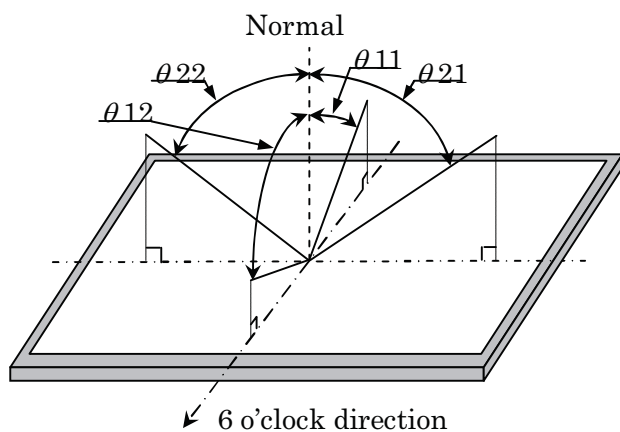

[Note 2] Definition of contrast ratio :

The contrast ratio is defined as the following.

$$\text{Contrast Ratio} = \frac{\text{Luminance (brightness) with all pixels white}}{\text{Luminance (brightness) with all pixels black}}$$

[Note 3] Definition of response time

The response time (τ_{rd}) is defined as the following,

$$\tau_{rd} = \{ \sum (\text{tr} : x - y) + \sum (\text{td} : x - y) \} / 20$$

τ_{rd} is the average value of the switching time from five gray levels (0%, 25%, 50%, 75% and 100%) to five gray levels (0%, 25%, 50%, 75% and 100%).

		Gray level of End (y)				
		0%	25%	50%	75%	100%
Gray level of Start (x)	0%		tr: 0%-25%	tr: 0%-50%	tr: 0%-75%	tr: 0%-100%
	25%	td: 25%-0%		tr: 25%-50%	tr: 25%-75%	tr: 25%-100%
	50%	td: 50%-0%	td: 50%-25%		tr: 50%-75%	tr: 50%-100%
	75%	td: 75%-0%	td: 75%-25%	td: 75%-50%		tr: 75%-100%
	100%	td: 100%-0%	td: 100%-25%	td: 100%-50%	td: 100%-75%	

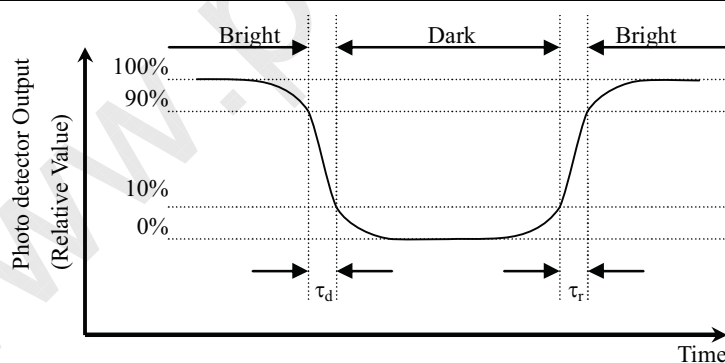

[Note 4] This shall be measured at center of the screen.

[Note 5] This value is valid when O/S driving is used at typical input time value.

[Note 6] Definition of white uniformity;

White uniformity is defined as the following with five measurements. (A~E)

$$\delta_w = \frac{\text{Maximum luminance of five points (brightness)}}{\text{Minimum luminance of five points (brightness)}}$$

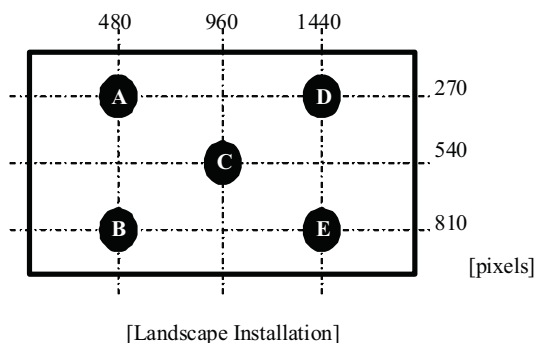

10 Packing form

- a) Piling number of cartons : 2 Maximum
- b) Packing quantity in one carton : 10pcs
- c) Carton size : 1772(W) × 1110(D) × 1153(H)
- d) Total mass of one carton filled with full modules : 350kg

11 Carton storage condition

Temperature	0°C to 40°C
Humidity	95% RH or less
Reference condition	20°C to 35°C, 85% RH or less (summer) 5°C to 15°C, 85% RH or less (winter) the total storage time (40°C, 95% RH) : 240h or less
Sunlight	Be sure to shelter a production from the direct sunlight.
Atmosphere	Harmful gas, such as acid and alkali which bites electronic components and/or wires must not be detected.
Notes	Be sure to put cartons on palette or base, don't put it on floor, and store them with keeping off a wall. Please take care of ventilation in storehouse and around cartons, and control temperature within the natural environment.
Storage life	1 year.

12 Reliability test item

No.	Test item	Condition
1	High temperature storage test	Ta=60°C 240h
2	Low temperature storage test	Ta=-25°C 240h
3	High temperature and high humidity operation test	Ta=40°C ; 95%RH 240h (No condensation)
4	High temperature operation test	Ta=50°C 240h
5	Low temperature operation test	Ta=0°C 240h
6	Vibration test (non-operation)	Frequency: 10~57Hz/Vibration width (one side): 0.075mm : 58~500Hz/Acceleration: 9.8 m/s ² Sweep time: 11 minutes Test period: 3 hours (1h for each direction of X, Y, Z)
7	ESD	At the following conditions, it is a thing without incorrect operation and destruction. (1)Non-operation: Contact electric discharge ±10kV Non-contact electric discharge ±20kV (2)Operation Contact electric discharge ±8kV Non-contact electric discharge ±15kV Conditions: 150pF, 330ohm

[Result evaluation criteria]

Under the display quality test condition with normal operation state, there shall be no change, which may affect practical display function.

13 Others

13.1. Serial label

The label that displays SHARP, product model LK695D3LA1W, a product number is stuck on the back of the module.

a) Overview

This label is stuck on the backlight chassis.

ex) LK695D3LA1WX or T [NSEC production]

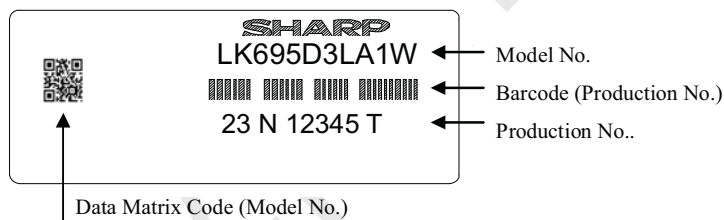

[Note1] Serial No.

- 1st ~ 99,999th/month :00001~99999
- 100,000th ~ 109,999th/month :A0000~A9999
- 110,000th ~ 119,999th/month :B0000~B9999
- ----- (without "I", "O")

How to express Production No.

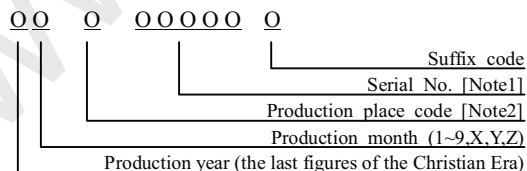

[Note2] Production place code

Code	Place	Model No. & Suffix Code
N	NSEC	LK695D3LA1W X or T

13.2. Packing Label

This label is stuck on each packing box.

ex) LK695D3LA1W (X or T)

社内品番 : (4S) LK695D3LA1W (X or T)	
Barcode(①)	
LotNO. : (1T) 2012. * **	
Barcode(②)	
Quantity : (Q) * pcs	
Barcode(③)	
ユーザ品番 :	
シャープ物流用ラベルです。	

① Model No.& Suffix Code

② Lot No.

③ Quantity

14 Precautions

- a) Be sure to turn off the power supply when inserting or disconnecting the cable.
- b) Be sure to design the cabinet so that the module can be installed without any extra stress such as warp or twist.
- c) Since the front polarizer is easily damaged, pay attention not to scratch it.
- d) Since long contact with water may cause discoloration or spots, wipe off water drop immediately.
- e) When the panel surface is soiled, wipe it with absorbent cotton or other soft cloth.
- f) Since the panel is made of glass, it may break or crack if dropped or bumped on hard surface. Handle with care.
- g) Since CMOS LSI is used in this module, take care of static electricity and take the human earth into consideration when handling.
- h) The module has some printed circuit boards (PCBs) on the back side, take care to keep them from any stress or pressure when handling or installing the module; otherwise some of electronic parts on the PCBs may be damaged.
- i) Observe all other precautionary requirements in handling components.
- j) When some pressure is added onto the module from rear side constantly, it causes display non-uniformity issue, functional defect, etc. So, please avoid such design.
- k) When giving a touch to the panel at power on supply, it may cause some kinds of degradation. In that case, once turn off the power supply, and turn on after several seconds again, and that is disappear.
- l) When handling LCD module and assembling them into cabinets, please be noted that long-term storage in the environment of oxidization or deoxidization gas and the use of such materials as reagent, solvent, adhesive, resin, etc. which generate these gasses, may cause corrosion and discoloration of the LCD modules.
- m) This LCD module is designed to prevent dust from entering into it. However, there would be a possibility to have a bad effect on display performance in case of having dust inside of LCD module. Therefore, please ensure to design your TV set to keep dust away around LCD module.
- n) This LCD module passes over the rust.
- o) Adjusting Vcom has been set optimally before shipment, so do not change any adjusted value. If adjusted value is changed, the specification may not be satisfied.
- p) Disassembling the module can cause permanent damage and should be strictly avoided.
- q) Please be careful since image retention may occur when a fixed pattern is displayed for a long time.
- r) The chemical compound, which causes the destruction of ozone layer, is not being used.
- s) In any case, please do not resolve this LCD module.
- t) This module is corresponded to RoHS.
- u) When any question or issue occurs, it shall be solved by mutual discussion.

2012.01.20

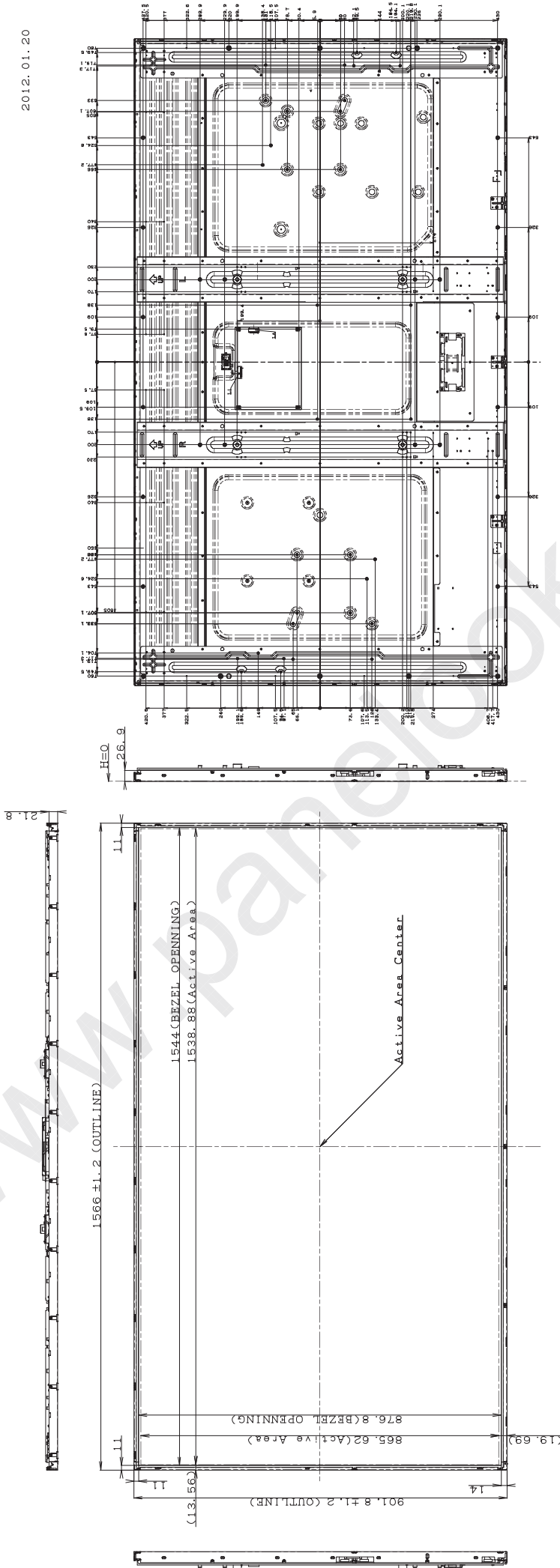

NOTE)
 1. UNSPECIFIED TOLERANCE TO BE ±2.0
 2. TOLERANCE OF ALL BOSS POSITION TO BE ±1.2

LK695D3LA1W MODULE OUTLINE DIMENSIONS

Parts Name	Material
Packing Case(Top)	Cardboard
Pack. Ado(Bottom)	PS
Pack. Ado(Top)	PS
Pack. Ado(SideA)	PS
Pack. Ado(SideB)	PS
CUSSION	PS
Packing Case(Trunk frame)	Cardboard
Plywood Palette	Plywoods
Antistatic Bag	PE($t=20\mu$)

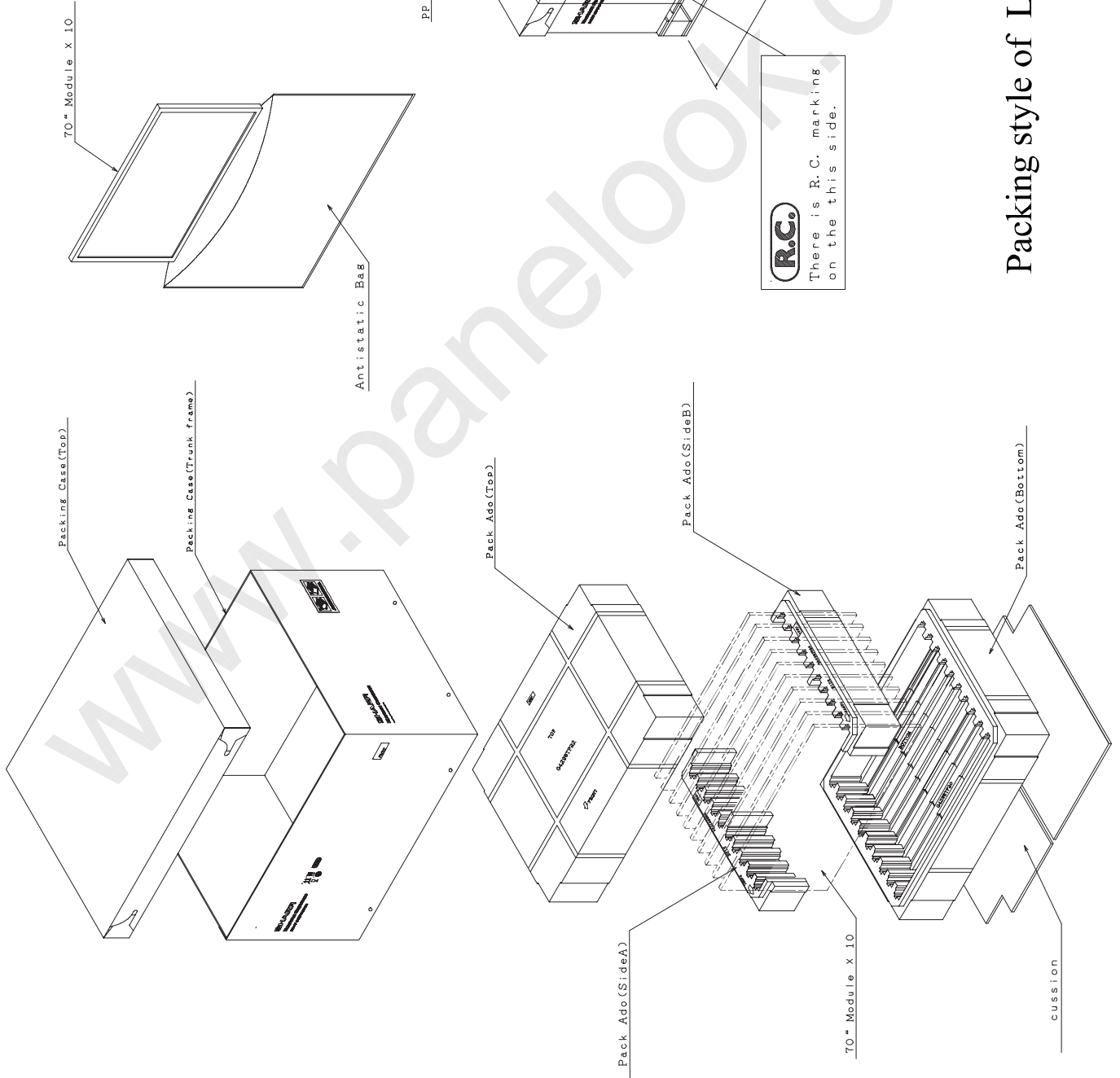

Packing style of LK695D3LAIW