

# NAN YA PLASTICS CORPORATION

SPECIFICATION OF  
LCD MODULE  
PRODUCT NO.: LKBHBTJ61M4S

SPEC. NO.: LMJ61-4-

CUSTOMER
APPROVED BY
DATE:

LCD DEPARTMENT  
ELECTRONIC MATERIALS DIVISION  
NAN YA PLASTICS CORPORATION  
201, TUNG HWA N. ROAD, TAIPEI  
TEL: 886-2-27122211 EXT. 5993~5995  
FAX: 886-2-27178253  
E-mail: lcdsales@npc.com.tw

EDITED ON : Apr. 20. 2007

Q.C. DEPT.	DESIGN MANAGER	DESIGN CHECK	DESIGNER
			W. R. HSU



# 1. MECHANICAL DATA

NO	ITEM	CONTENTS	UNIT
1	Product No.	LKBHBTJ61M4S	-
2	Module Size	168.0 (W) x 111.0 (H) x 7.5 (D)	mm
3	Dot Size	0.10 (W) x 0.34 (H)	mm
4	Dot Pitch	0.12 (W) x 0.36 (H)	mm
5	Number of Dots	320 xRGB(W) x240 (H)	Dot
6	Duty	1/240	-
7	LCD Display Mode	FSTN, Color STN Module	-
8	Rear Polarizer	Color Transmissive Type	-
9	Viewing Direction	6	O'clock
10	Backlight	CCFL	-
11	Controller	Excluded	-
12	DC/DC Converter	Excluded	-
13	Touch Panel	Excluded	-
14	Weight	195 g(approx.)	g

Note :

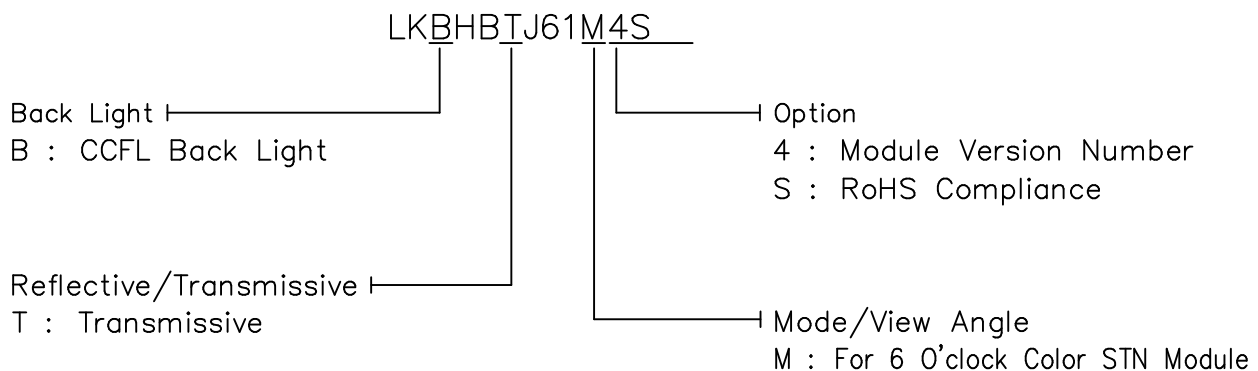

**RoHS Compliance.**

Nan Ya guarantees that this project doesn't include any materials (6 materials) or includes less than specified quantities which are regulated by RoHS Compliance.

## 2. ABSOLUTE MAXIMUM RATINGS

### (1) ELECTRICAL ABSOLUTE RATINGS

VSS=0V

	SYMBOL	MIN.	MAX.	UNIT	COMMENT
Power Supply for Logic	VDD-VSS	-0.3	6.5	V	
Power Supply for LCD Drive	VEE-VSS	0	30	V	
Input Voltage	VI	-0.3	VDD+0.3	V	
Static Electricity	-	-	-	-	Note 1

### (2) ENVIRONMENTAL ABSOLUTE MAXIMUM RATINGS

ITEM	NORMAL TEMP.			
	OPERATING		STORAGE	
	MIN.	MAX.	MIN.	MAX.
Ambient Temperature	-20	70	-40	80
Humidity (Without Condensation)	Note 2,4,5		Note 3,4	

Note 1 LCM should be grounded during handling LCM.

Note 2  $T_a \leq 70^\circ\text{C}$  : 75%RH max

Note 3 Please refer to item of reliability test

Note 4 Background color will change slightly depending on ambient temperature.  
That phenomenon is reversible.

Note 5 Excluded CCFL Backlight.

### 3. ELECTRICAL CHARACTERISTICS

#### 3-1. ELECTRICAL CHARACTERISTICS OF LCM

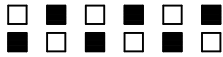
ITEM	SYMBOL	CONDITION	MIN.	TYP.	MAX.	UNIT	
Power Supply for Logic	VDD-VSS	-	4.5	5.0	5.5	V	
Power Supply for Logic	VDD-VSS	-	3.0	3.3	3.6	V	
Input Voltage	VIH	H level	0.8VDD	-	VDD	V	
	VIL	L level	0	-	0.2VDD		
Recommended LC Driving Voltage	VEE-VSS (Vop)	Duty= 1/240	-20°C	23.7	24.2	24.7	V
			0°C	22.6	23.1	23.6	
			25°C	22.1	22.6	23.1	
			50°C	21.8	22.3	22.8	
			70°C	21.0	21.5	22.0	
Power Supply Current	IDD	VDD-VSS=3.3V/5.0V VEE-VSS=22.6V Ta=25°C Pattern: 	-	2.5	5	mA	
	IEE		-	10	15		
Surface Luminance of LCM	L	IL=5 mArms Ta=25°C Pattern: Dots All ON(White)	70	90	-	cd/m <sup>2</sup>	
		IL=5 mArms Ta=25°C Pattern: Dots All OFF(Black)	-	6	-		
Recommended Frame Frequency for Optimum Contrast	FRM	-	115	120	125	Hz	

### 3-2.ELECTRICAL CHARACTERISTICS OF BACKLIGHT

Used Lamp Rating

Temp.=25°C

ITEM	SYMBOL	MIN.	TYP.	MAX.	UNIT	REMARK
Lamp Voltage	$V_L$	-	296	-	Vrms	-
Lamp current	$I_L$	-	5	-	mArms	-
Lamp power consumption	$P_L$	-	1.48	-	W	(*1)
Starting voltage	$V_S$	-	-	460	Vrms	$T_a=25^\circ\text{C}$
		-	-	580	Vrms	$T_a=0^\circ\text{C}$
Lamp life time	$L_L$	-	20000	-	hrs	at $I_L = 5 \text{ mArms}$ $T_a=25^\circ\text{C}$ (*2)

(\*1) Power consumption excluded inverter loss .

(\*2) Lamp life time is defined as follows : The final brightness is at 50% of original brightness .

(\*3) a. Please follow the table of Lamp Characteristics shown above if not to use the inverter recommended by Nan Ya .

b. If customers want to design inverter by themselves , please inform Nan Ya to offer the detail lamp specification .

### 3-3.ELECTRICAL CHARACTERISTICS OF RECOMMENDED INVERTER TDK CXA-L10L

#### 3-3-1 GENERAL SPECIFICATIONS

OPERATION TEMPERATURE : -10°C~60°C

STORAGE TEMPERATURE : -20°C~85°C

DIMENSION : 44.0(L)mm x 21.0(W)mm x MAX 18.0(H)mm

#### 3-3-2 PIN ASSIGNMENTS

INPUT (CN1) CONNECTOR :

OUTPUT (CN2) CONNECTOR :

NO.	FUNCTION
1	VIN
2	GND

NO.	FUNCTION
3	OUT1
4	OUT2
5	OUT GND

#### 3-3-3 RELATIONSHIP BETWEEN VIN & TUBE CURRENT

ITEM	SYMBOL	MIN.	TYP.	MAX.	UNIT	REMARK
Input Voltage	VIN	-	10.1	-	V	
No Load Output Voltage	Vs	800	900	-	Vrms	
Tube Current	IL	-	5	-	mA	
Working Frequency	F	30	35	40	KHz	

## 4. OPTICAL CHARACTERISTICS

### 4-1. Optical Char. of Wide Temp. Mode

AT  $V_{OP}$

ITEM MODE		Cr(Contrast Ratio)										$\theta$ (Viewing Angle)		$\theta$ (Viewing Angle)	
		-20°C		0°C		25°C		50°C		70°C		25°C		25°C	
		MIN.	TYP.	MIN.	TYP.	MIN.	TYP.	MIN.	TYP.	MIN.	TYP.	MIN.	TYP.	MIN.	TYP.
T	M	12	18	14	20	17	25	3.5	5	1.4	2	-	F: 55 R: 30	-	L: 45 R: 45
NOTE		NOTE 3,6										NOTE 3,5			

NOTE :

T : Transmission

M : Color STN Module, 6 O'clock

AT  $\phi=0^\circ \theta=0^\circ$

ITEM	SYMBOL	CONDITION	MIN.	TYP.	MAX.	UNIT	NOTE
Response Time (rise)	Tr	-20℃	2300	2900	4300	ms	NOTE 2,3
		0℃	640	800	1200		
		25℃	240	300	450		
		50℃	80	100	150		
		70℃	45	55	80		
Response Time (fall)	Tf	-20℃	1500	1800	2700	ms	NOTE 2,3
		0℃	360	450	670		
		25℃	80	100	150		
		50℃	48	60	90		
		70℃	32	40	60		



4-2. Color of CIE Coordinate

Ta = 25°C

ITEM		SYMBOL	CONDITION	VALUE	NOTE
Color of CIE Coordinate	Red	X	$\phi=0^\circ, \theta=0^\circ$	0.53	Note*
		y		0.31	
	Green	X	$\phi=0^\circ, \theta=0^\circ$	0.29	
		y		0.52	
	Blue	X	$\phi=0^\circ, \theta=0^\circ$	0.15	
		y		0.13	
	White	X	$\phi=0^\circ, \theta=0^\circ$	0.29	
		y		0.30	

Note\* Measuring at position 3 on Fig.1  
CIE chromaticity diagram

Tolerance :  $\pm 0.05$

Fig.1

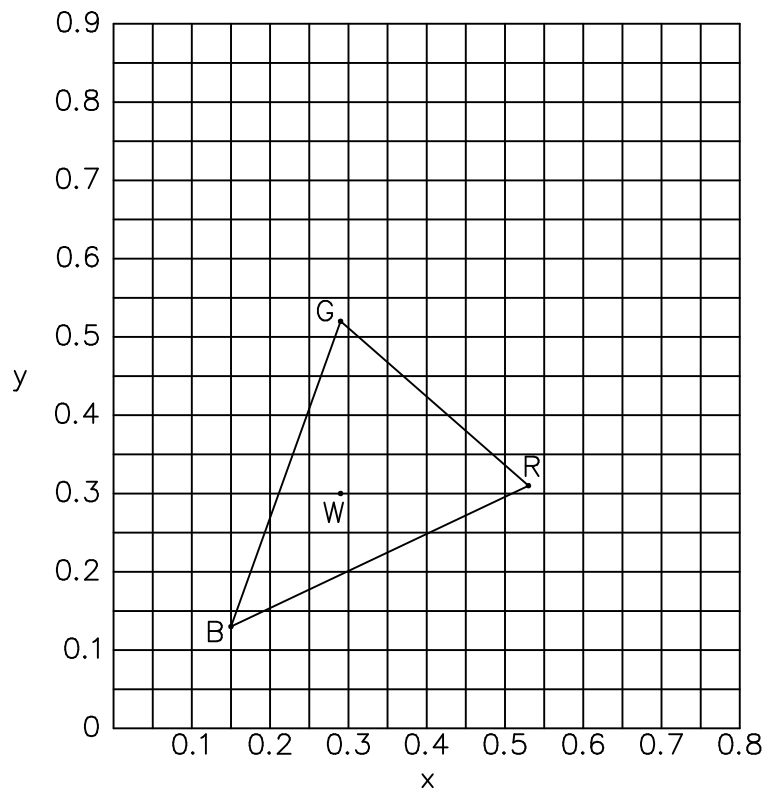

(NOTE 1)

Definition of Operation Voltage(Vop)

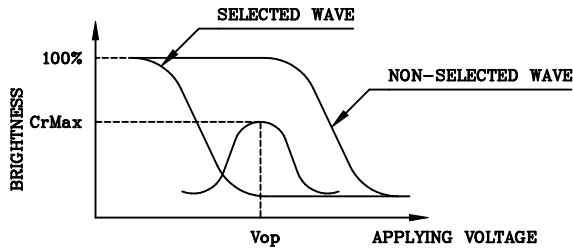

(positive type)

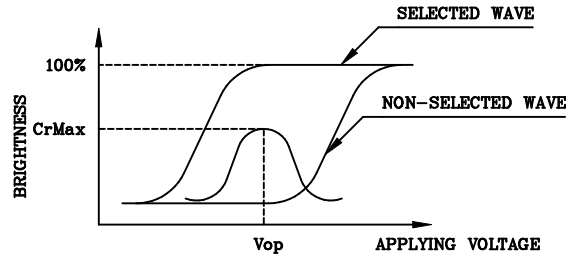

(negative type)

\*Conditions

Viewing Angle : 0  
 Frame Frequency : 120Hz  
 Applying Waveform : 1/N duty 1/a bias

(NOTE 2)

Definition of Response Time(Tr,Tf)

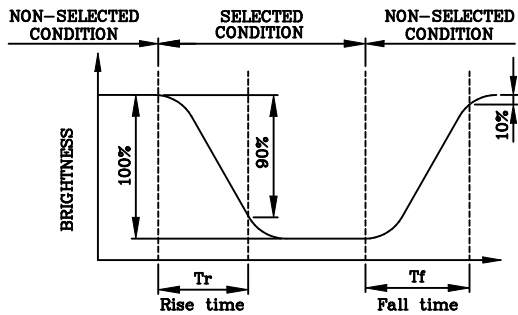

(positive type)

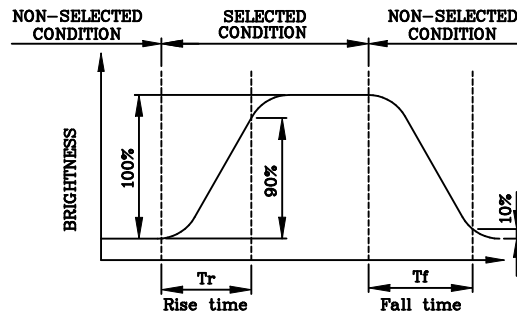

(negative type)

\*Conditions

Operating Voltage : Vop  
 Viewing Angle (θ,φ) : (0,0)  
 Frame Frequency : 120Hz  
 Applying Waveform : 1/N duty 1/a bias

(NOTE 3)

Description of Measuring Equipment and Driving Waveforms

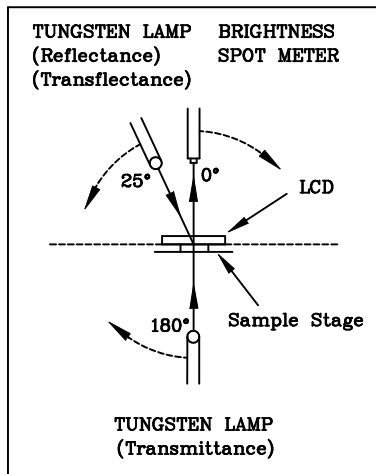

CONST.  
 TEMP.  
 CHAMBER

Multiplex Driving ( 1/N duty 1/a bias )

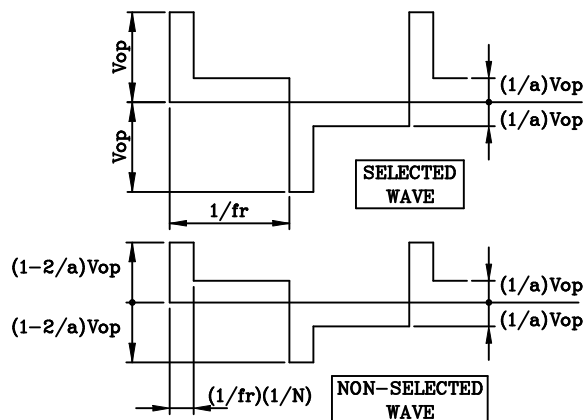

(NOTE 4)

Definition of Viewing Direction

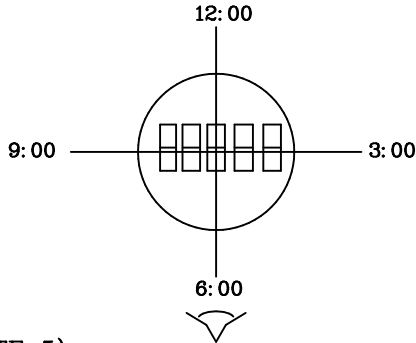

(NOTE 5)

Definition of Viewing Angle

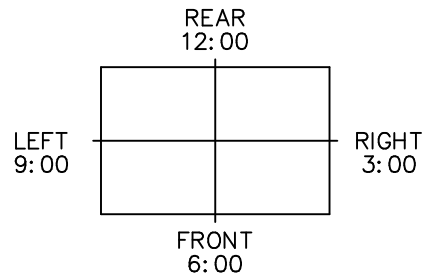
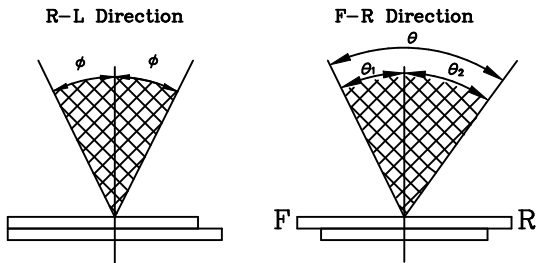

\*For This Product  
 The Viewing Direction Is 6 O'clock  
 So  $\theta_1 > \theta_2$

$\theta = \theta_1 + \theta_2$

\*Conditions

Operating Voltage :  $V_{op}$   
 Frame Frequency : 120Hz  
 Applying Waveform : 1/N duty 1/a bias  
 Contrast Ratio : larger than 2

(NOTE 6)

Definition of Contrast Ratio (Cr)

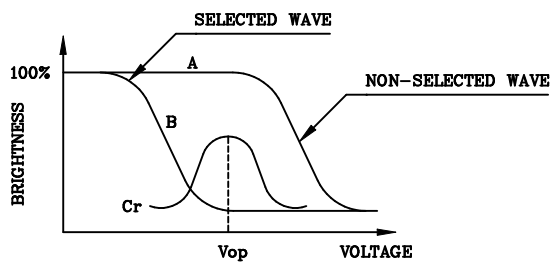

(positive type)

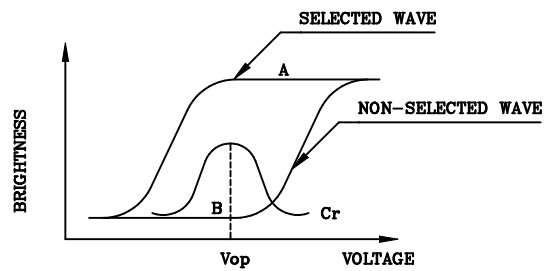

(negative type)

Contrast Ratio :  $Cr = A/B$

\*Conditions

Viewing Angle : 0  
 Frame Frequency : 120Hz  
 Applying Waveform : 1/N duty 1/a bias

## 5. BLOCK DIAGRAM

LCD

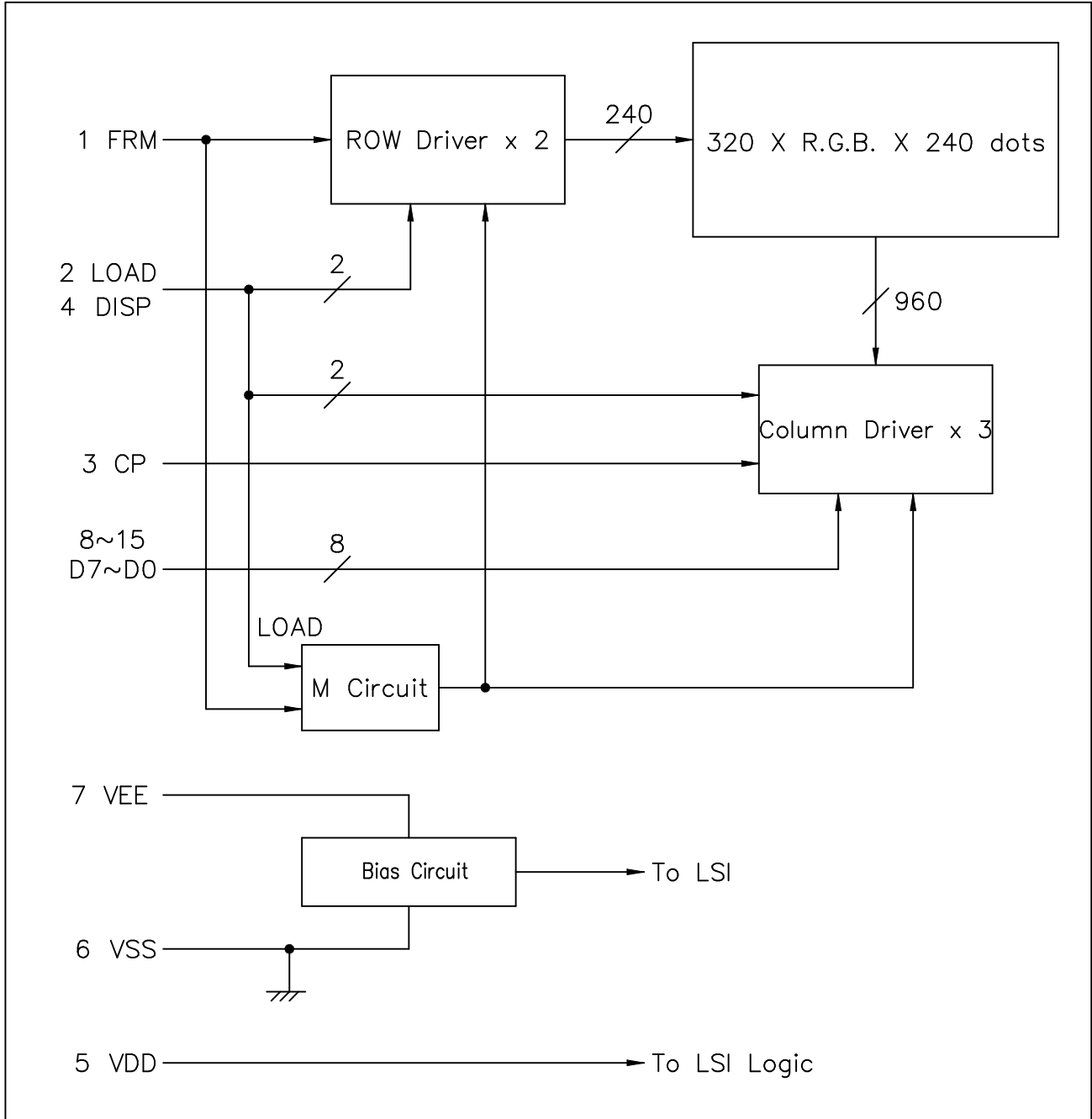

CCFL

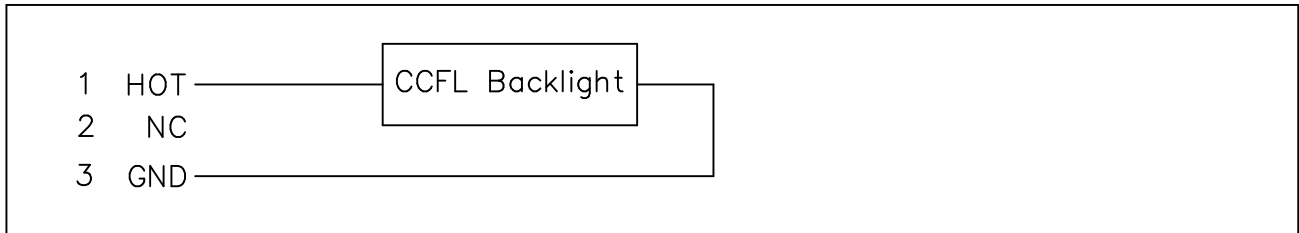

## 6. INTERNAL PIN CONNECTION

### LCD

Pin No.	Symbol	Function	Level
1	FRM	Synchronous signal for driving scanning line	H
2	LOAD	Data signal latch clock	H → L
3	CP	Data signal shift clock	H → L
4	DISP	Display control signal	H(ON),L(OFF)
5	VDD	Power supply for logic	—
6	VSS	GND	—
7	VEE	Power supply for LCD	—
8	D7	Display data	H(ON),L(OFF)
9	D6		
10	D5		
11	D4		
12	D3		
13	D2		
14	D1		
15	D0		

### CCFL

Pin No.	Symbol	Function	Level
1	HOT	Power Supply for CCFL(HOT)	AC
2	NC	NO Connection	—
3	GND	Power Supply for CCFL(GND)	—

LCD CONNECTOR :  
MOLEX 53261-1571  
CORRESPONDABLE LCD CONNECTOR :  
MOLEX 51021-1500 or COMPATIBLE  
CCFL CONNECTOR :  
BHR-03VS-1(JST)  
CORRESPONDABLE CCFL CONNECTOR :  
SM02-(8.0)B-BHS-1(JST) or Compatible

## 7. POWER SUPPLY

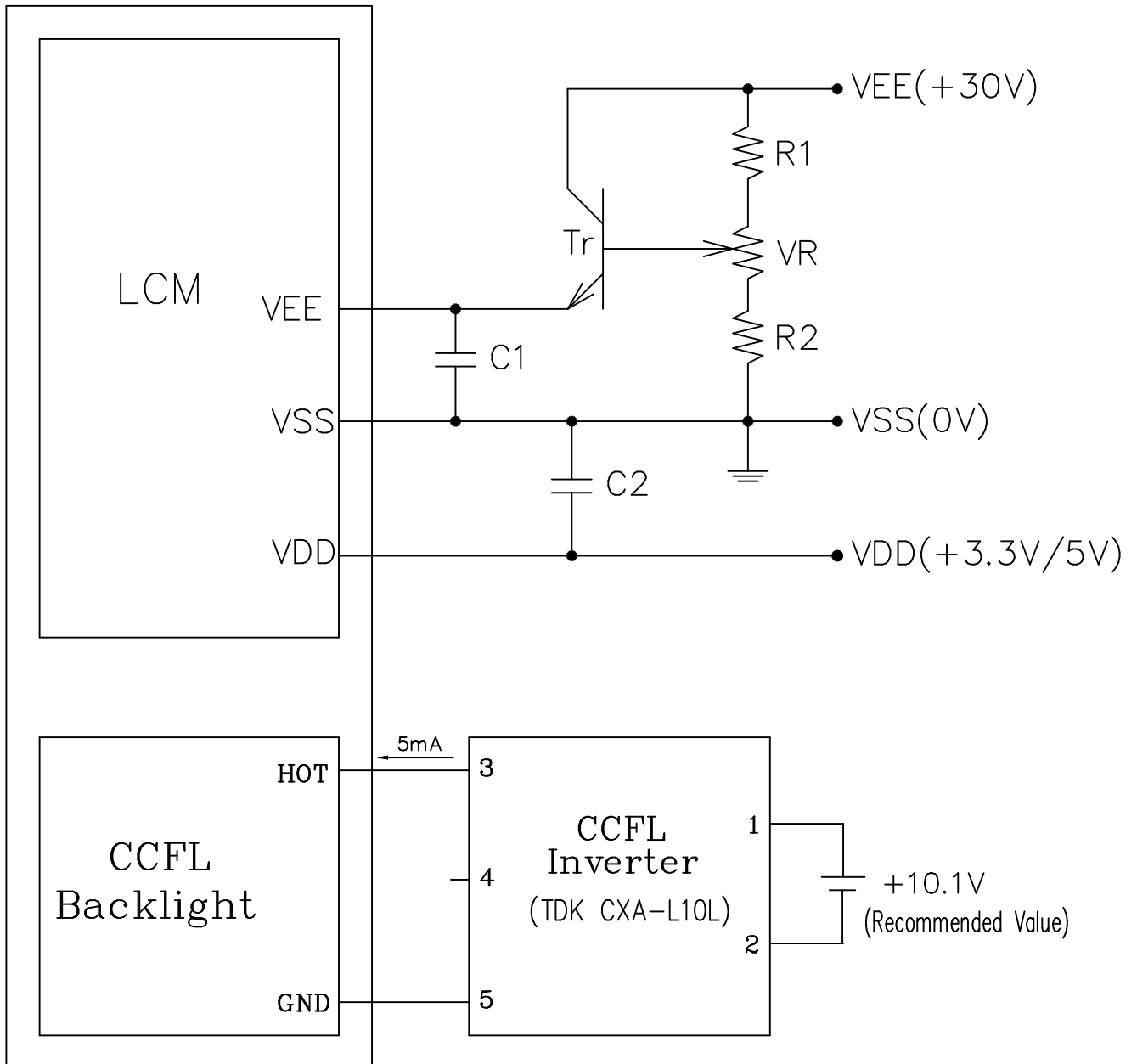

$$1. R1 + R2 + VR = 10 \sim 20K \Omega$$

$$C1, C2 = 10 \mu F$$

# 8. TIMING CHARACTERISTICS

## 8-1. INTERFACE TIMING

VDD=3.3V ± 10%

Parameter	SYMBOL	MIN.	MAX.	UNIT
CLOCK PULSE CYCLE TIME	$t_{wck}$	66	-	ns
CLOCK PULSE HIGH LEVEL WIDTH	$t_{wckH}$	23	-	ns
CLOCK PULSE LOW LEVEL WIDTH	$t_{wckL}$	23	-	ns
LATCH PULSE HIGH LEVEL WIDTH	$t_{wLPH}$	30	-	ns
CP→LOAD RISE TIME	$t_{LD}$	10	-	ns
CP→LOAD FALL TIME	$t_{SL}$	30	-	ns
LOAD→CP RISE TIME	$t_{LS}$	30	-	ns
LOAD→CP FALL TIME	$t_{LH}$	30	-	ns
CLOCK PULSE RISE/FALL TIME	$t_r, t_f$	-	30	ns
DATA SETUP TIME	$t_{DS}$	10	-	ns
DATA HOLD TIME	$t_{DH}$	25	-	ns
DISP LOW LEVEL WIDTH	$t_{WDL}$	1.2	-	μs
DISP CANCELLATION TIME	$t_{SD}$	100	-	ns

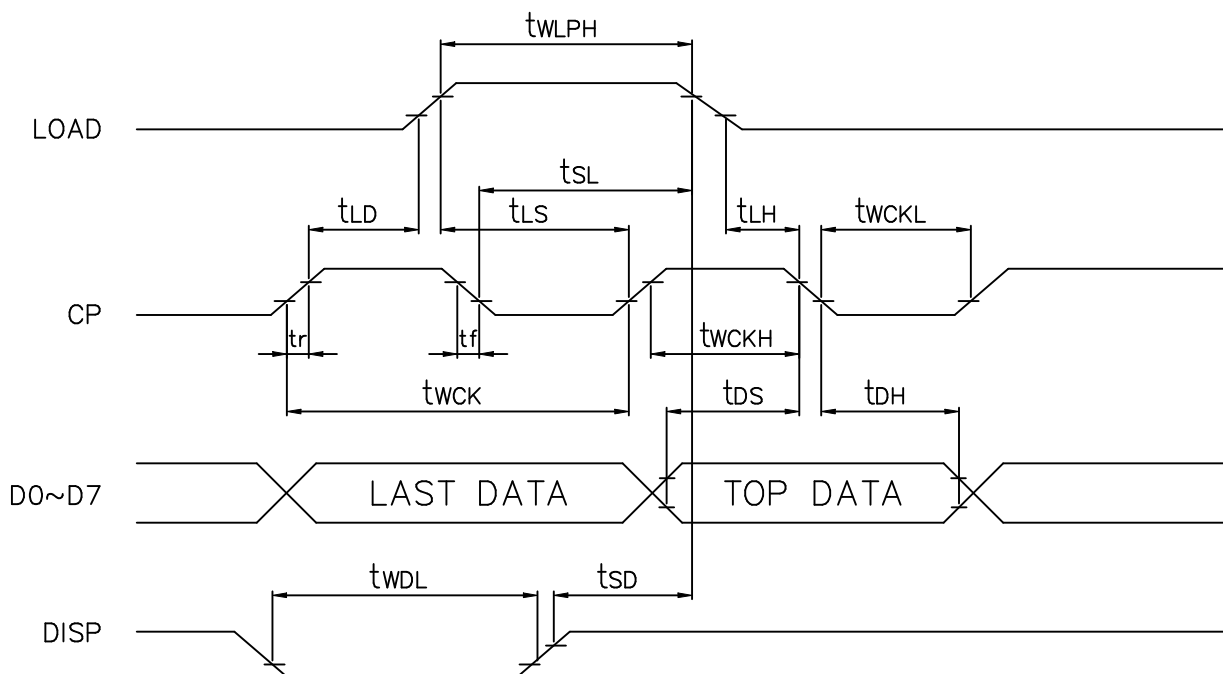

8-2. TIMING CHART

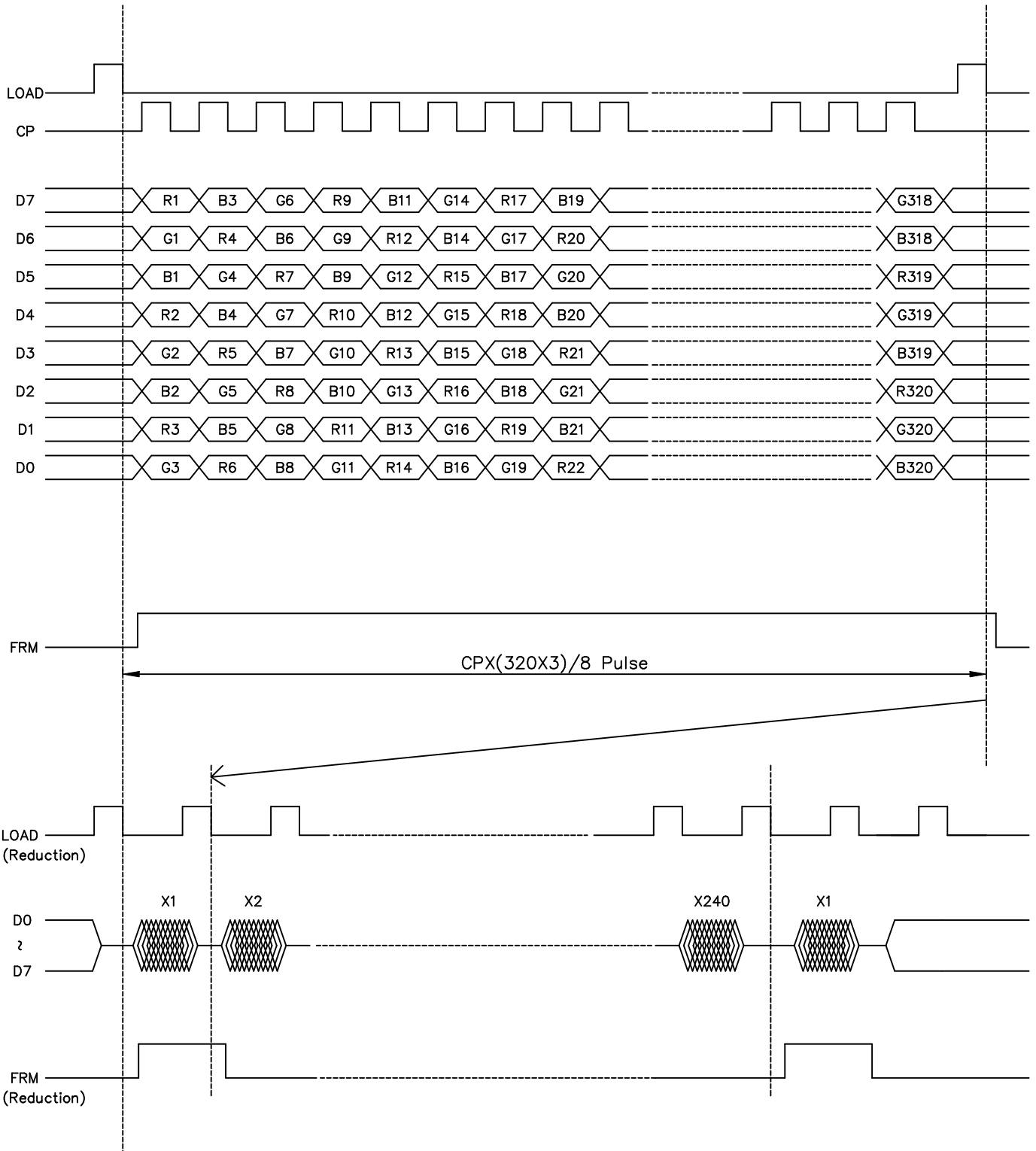



8-3.POWER ON/OFF TIMING

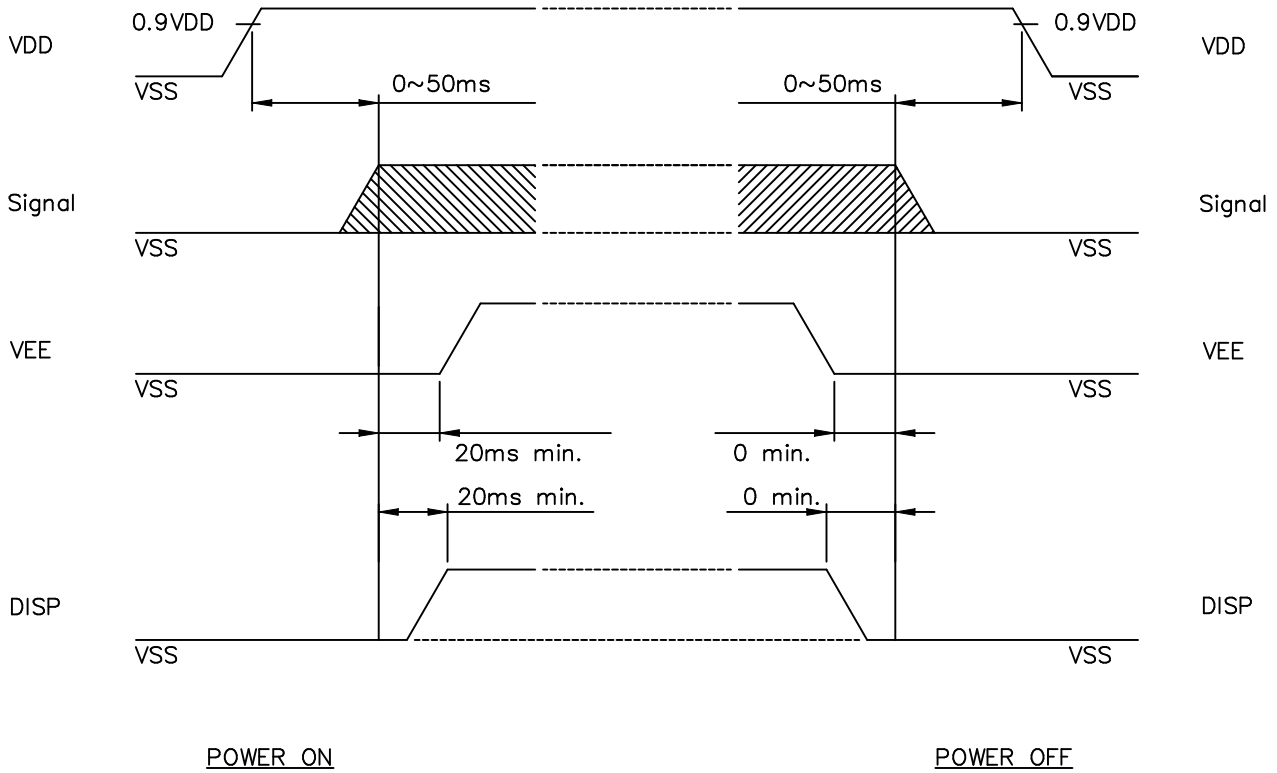

The missing pixels may occur when the LCM is driven beyond above power interface timing sequence.

8-4.DISPLAY PATTERN

START DATA

	Y1			Y2			Y3				Y318			Y319			Y320		
X1	R1	G1	B1	R2	G2	B2	R3	G3	B3		R318	G318	B318	R319	G319	B319	R320	G320	B320
	D7	D6	D5	D4	D3	D2	D1	D0	D7		D0	D7	D6	U5	D4	D3	D2	D1	D0
X2	R1	G1	B1	R2	G2	B2	R3	G3	B3		R318	G318	B318	R319	G319	B319	R320	G320	B320
	D7	D6	D5	D4	D3	D2	D1	D0	D7		D0	D7	D6	U5	D4	D3	D2	D1	D0
X239	R1	G1	B1	R2	G2	B2	R3	G3	B3		R318	G318	B318	R319	G319	B319	R320	G320	B320
	D7	D6	D5	D4	D3	D2	D1	D0	D7		D0	D7	D6	U5	D4	D3	D2	D1	D0
X240	R1	G1	B1	R2	G2	B2	R3	G3	B3		R318	G318	B318	R319	G319	B319	R320	G320	B320
	D7	D6	D5	D4	D3	D2	D1	D0	D7		D0	D7	D6	U5	D4	D3	D2	D1	D0

## 9. RELIABILITY TEST

### WIDE TEMPERATURE RELIABILITY TEST

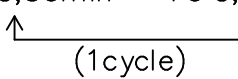
NO	ITEM	CONDITION			STANDARD	NOTE
1	High Temp. Storage	80°C	120Hrs		Appearance without defect	
2	Low Temp. Storage	-40°C	120Hrs		Appearance without defect	
3	High Temp. & High Humi. Storage	60°C 90%RH	120Hrs		Appearance without defect	
4	High Temp. Operating Display	70°C	120Hrs		Appearance without defect	
5	Low Temp. Operating Display	-20°C	120Hrs		Appearance without defect	
6	Thermal Shock	-20°C, 30min → 70°C, 30min  (1cycle)			Appearance without defect	10 cycles

Inspection Provision

1. Purpose

The NAN YA inspection provision provides outgoing inspection provision and its expected quality level based on our outgoing inspection of NAN YA LCD produces.

2. Applicable Scope

The NAN YA inspection provision is applicable to the arrangement in regard to outgoing inspection and quality assurance after outgoing.

3. Technical Terms

3-1 NAN YA Technical Terms

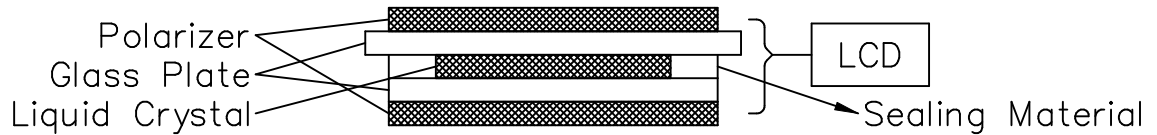

4. Outgoing Inspection

4-1 Inspection Method

MIL-STD-105E Level II Regular inspection

4-2 Inspection Standard

	Item		AQL(%)	Remarks
Major Defect	Dots	Opens Shorts Erroneous operation	0.4	faults which substantially lower the practicality and the initial purpose difficult to achieve.
	Solder appearance	Shorts Loose		
	Cracks	Display surface cracks		

	Dimensions	External from Dimensions	0.4	
Minor Defect	Inside the glass	Black spots	0.65	faults which appear to pose almost no obstacle to the practicality, effective use, and operation.
	Polarizing plate	Scratches, foreign Matter, air bubbles, and peeling		
	Dots	Pinhole, deformation		
	Color tone	Color unevenness		
	Solder appearance	Cold solder Solder projections		

4-3 Inspection Provisions  
\*Viewing Area Definition

Fig. 1

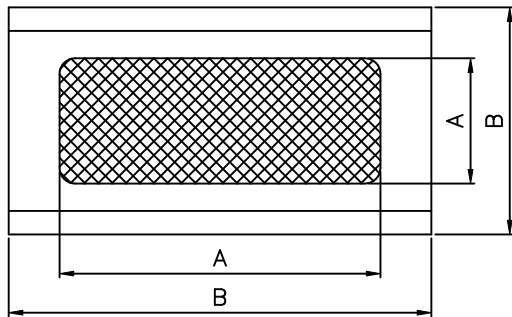

A : Zone Viewing Area  
B : Zone Glass Plate Outline

\*Inspection place to be 500 to 1000 lux illuminance uniformly without glaring.  
The distance between luminous source(daylight fluorescent lamp and cool white fluorescent lamp) and sample to be 30cm to 50cm.

\*Test and measurement are performed under the following conditions, unless otherwise specified.

Temperature            20± 15°C  
Humidity                65± 20%R.H.  
Pressure                860~1060hPa(mmbar)

In case of doubtful judgment, it is performed under the following conditions.

Temperature            20± 2°C  
Humidity                65± 5%R.H.  
Pressure                860~1060hPa(mmbar)

5.Specification for quality check  
5-1 Electrical characteristics

NO.	Item	Criterion
1	Non operational	Fail
2	Miss operating	Fail
3	Missing dot	Fail
4	Contrast irregular	Fail
5	Response time	Within Specified value
6	Backlight turn on/off	Within Specified value

5-2 External Appearance Defect

NO.	Item	Criterion																							
1	Black spots, foreign matter, and white spots (Including light leakage due to pinholes of polarizing plates, etc.)	<p>(1)-1-Spots</p> <table border="1" data-bbox="703 488 1401 817"> <thead> <tr> <th>Average Diameter(mm):D</th> <th>Number of pieces permitted</th> <th>Minimum Space</th> </tr> </thead> <tbody> <tr> <td><math>D \leq 0.2</math></td> <td>Ignore</td> <td>-</td> </tr> <tr> <td><math>0.2 &lt; D \leq 0.3</math></td> <td>5</td> <td>10mm</td> </tr> <tr> <td><math>0.3 &lt; D \leq 0.4</math></td> <td>2</td> <td>30mm</td> </tr> <tr> <td><math>0.4 &lt; D</math></td> <td>0</td> <td></td> </tr> </tbody> </table> <p>Number of total pieces is set to within 5 pieces.</p> <p>Note that when there are 2 pieces or more, they are not to be concentrated. Set as: Average diameter = (Long diameter + Short diameter)/2</p> <p>(1)-2-Blurred Spots(At lighting condition)</p> <table border="1" data-bbox="703 1234 1337 1464"> <thead> <tr> <th>Average Diameter(mm):D</th> <th>Number of pieces permitted</th> </tr> </thead> <tbody> <tr> <td><math>D \leq 0.3</math></td> <td>Ignore</td> </tr> <tr> <td><math>0.3 &lt; D \leq 0.75</math></td> <td>5</td> </tr> <tr> <td><math>0.75 &lt; D</math></td> <td>0</td> </tr> </tbody> </table> <p>Number of total pieces is set to within 5 pieces.</p> <p>Note that when there are 2 pieces or more, they are not to be concentrated. Set as: Average diameter = (Long diameter + Short diameter)/2</p>	Average Diameter(mm):D	Number of pieces permitted	Minimum Space	$D \leq 0.2$	Ignore	-	$0.2 < D \leq 0.3$	5	10mm	$0.3 < D \leq 0.4$	2	30mm	$0.4 < D$	0		Average Diameter(mm):D	Number of pieces permitted	$D \leq 0.3$	Ignore	$0.3 < D \leq 0.75$	5	$0.75 < D$	0
Average Diameter(mm):D	Number of pieces permitted	Minimum Space																							
$D \leq 0.2$	Ignore	-																							
$0.2 < D \leq 0.3$	5	10mm																							
$0.3 < D \leq 0.4$	2	30mm																							
$0.4 < D$	0																								
Average Diameter(mm):D	Number of pieces permitted																								
$D \leq 0.3$	Ignore																								
$0.3 < D \leq 0.75$	5																								
$0.75 < D$	0																								

1	Line	<p>(1)-1-Lines</p> <table border="1" data-bbox="705 443 1430 721"> <thead> <tr> <th>Width(mm): W</th> <th>Length(mm): L</th> <th>Number of pieces permitted</th> </tr> </thead> <tbody> <tr> <td><math>W \leq 0.03</math></td> <td>Ignore</td> <td>Ignore</td> </tr> <tr> <td><math>0.03 &lt; W \leq 0.08</math></td> <td><math>L \leq 4</math></td> <td>2</td> </tr> <tr> <td><math>0.08 &lt; W \leq 0.1</math></td> <td><math>L \leq 1</math></td> <td>1</td> </tr> </tbody> </table> <p>Object exceeding 0.1mm follow the standards of the spots form. Note that when there are 2 pieces or more, they are not to be concentrated.</p> <p>(1)-2-Blurred Lines(At lighting condition)</p> <table border="1" data-bbox="705 1021 1430 1299"> <thead> <tr> <th>Width(mm): W</th> <th>Length(mm): L</th> <th>Number of pieces permitted</th> </tr> </thead> <tbody> <tr> <td><math>W \leq 0.03</math></td> <td>Ignore</td> <td>Ignore</td> </tr> <tr> <td><math>0.03 &lt; W \leq 0.08</math></td> <td><math>L \leq 3</math></td> <td>6</td> </tr> <tr> <td><math>0.08 &lt; W</math></td> <td><math>3 &lt; L</math></td> <td>None</td> </tr> </tbody> </table> <p>Object exceeding 0.1mm follow the standards of the spots form. Note that when there are 2 pieces or more, they are not to be concentrated.</p>	Width(mm): W	Length(mm): L	Number of pieces permitted	$W \leq 0.03$	Ignore	Ignore	$0.03 < W \leq 0.08$	$L \leq 4$	2	$0.08 < W \leq 0.1$	$L \leq 1$	1	Width(mm): W	Length(mm): L	Number of pieces permitted	$W \leq 0.03$	Ignore	Ignore	$0.03 < W \leq 0.08$	$L \leq 3$	6	$0.08 < W$	$3 < L$	None
Width(mm): W	Length(mm): L	Number of pieces permitted																								
$W \leq 0.03$	Ignore	Ignore																								
$0.03 < W \leq 0.08$	$L \leq 4$	2																								
$0.08 < W \leq 0.1$	$L \leq 1$	1																								
Width(mm): W	Length(mm): L	Number of pieces permitted																								
$W \leq 0.03$	Ignore	Ignore																								
$0.03 < W \leq 0.08$	$L \leq 3$	6																								
$0.08 < W$	$3 < L$	None																								
2	Scratches(Glass, reflection plates, and polarizing plates)	In accordance with black spots. (At non lighting condition)																								
3	Color irregular	Not remarkable color irregular.																								

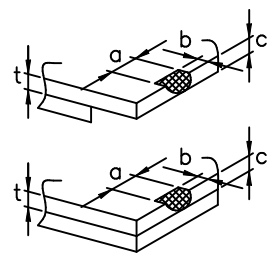
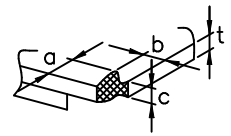
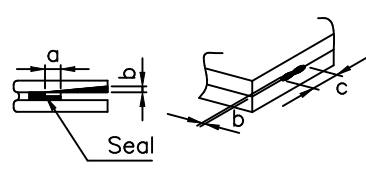
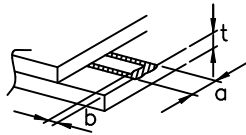
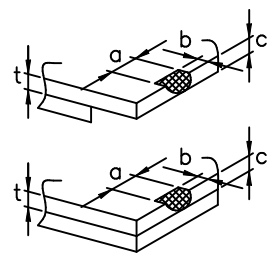
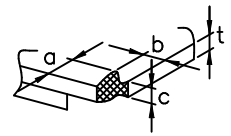
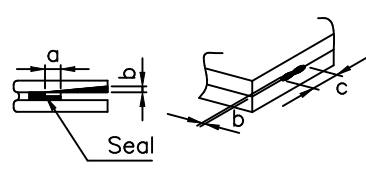
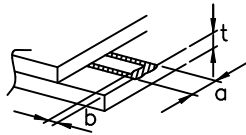
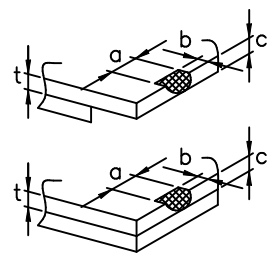
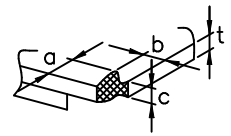
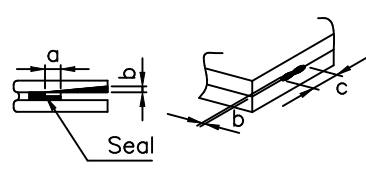
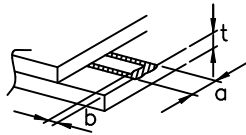

4	Air bubbles polarizing plates, and reflection plates	<table border="1" data-bbox="702 392 1204 683"> <tr> <td data-bbox="702 392 949 537">Average Diameter (mm): D</td> <td data-bbox="949 392 1204 537">Number of pieces permitted</td> <td data-bbox="1204 392 1449 683" rowspan="2">Average diameter = (Long diameter + Short diameter)/2</td> </tr> <tr> <td data-bbox="702 537 949 683">D ≤ 0.3 0.3 &lt; D</td> <td data-bbox="949 537 1204 683">Ignore 0</td> </tr> </table> <p data-bbox="702 694 1449 772">Note that when there are 4 pieces or more, they are not to be concentrated.</p>		Average Diameter (mm): D	Number of pieces permitted	Average diameter = (Long diameter + Short diameter)/2	D ≤ 0.3 0.3 < D	Ignore 0					
Average Diameter (mm): D	Number of pieces permitted	Average diameter = (Long diameter + Short diameter)/2											
D ≤ 0.3 0.3 < D	Ignore 0												
5	Cracks	<table border="1" data-bbox="654 784 1449 1946"> <tr> <td data-bbox="654 784 1045 1164"> <p data-bbox="654 784 1045 840">(1) General crack</p>  </td> <td data-bbox="1045 784 1449 1164"> <p data-bbox="1045 784 1449 1164"> <math>a \leq 5</math>  <math>b \leq 2</math>  <math>c \leq t</math>                      Where, a and b are ignored when less than or equal to 0.5                      The numbers of pieces are set at up to 5 pieces.                 </p> </td> </tr> <tr> <td data-bbox="654 1164 1045 1355"> <p data-bbox="654 1164 1045 1220">(2) Corner crack</p>  </td> <td data-bbox="1045 1164 1449 1355"> <p data-bbox="1045 1164 1449 1355"> <math>a \leq 2.5</math>  <math>b \leq 2.5</math>  <math>c \leq t</math>  <math>a + b \leq 4</math> </p> </td> </tr> <tr> <td data-bbox="654 1355 1045 1624"> <p data-bbox="654 1355 1045 1411">(3) Seal portion crack</p>  </td> <td data-bbox="1045 1355 1449 1624"> <p data-bbox="1045 1355 1449 1624"> <math>a \leq \text{The seal width} \times 1/3</math>  <math>b \leq t \times 2/3</math>  <math>c \leq 5</math>                      The numbers of pieces are set at up to 5 pieces.                 </p> </td> </tr> <tr> <td data-bbox="654 1624 1045 1848"> <p data-bbox="654 1624 1045 1680">(4) ITO Pin crack</p>  </td> <td data-bbox="1045 1624 1449 1848"> <p data-bbox="1045 1624 1449 1848"> <math>a \leq 5</math>  <math>b \leq 1/3 \text{ pin length}</math>  <math>c \leq t</math> </p> </td> </tr> <tr> <td data-bbox="654 1848 1045 1946"> <p data-bbox="654 1848 1045 1946">(5) Progressive cracks</p> </td> <td data-bbox="1045 1848 1449 1946"> <p data-bbox="1045 1848 1449 1946">All taken to be unacceptable.</p> </td> </tr> </table>		<p data-bbox="654 784 1045 840">(1) General crack</p> 	<p data-bbox="1045 784 1449 1164"> <math>a \leq 5</math>  <math>b \leq 2</math>  <math>c \leq t</math>                      Where, a and b are ignored when less than or equal to 0.5                      The numbers of pieces are set at up to 5 pieces.                 </p>	<p data-bbox="654 1164 1045 1220">(2) Corner crack</p> 	<p data-bbox="1045 1164 1449 1355"> <math>a \leq 2.5</math>  <math>b \leq 2.5</math>  <math>c \leq t</math>  <math>a + b \leq 4</math> </p>	<p data-bbox="654 1355 1045 1411">(3) Seal portion crack</p> 	<p data-bbox="1045 1355 1449 1624"> <math>a \leq \text{The seal width} \times 1/3</math>  <math>b \leq t \times 2/3</math>  <math>c \leq 5</math>                      The numbers of pieces are set at up to 5 pieces.                 </p>	<p data-bbox="654 1624 1045 1680">(4) ITO Pin crack</p> 	<p data-bbox="1045 1624 1449 1848"> <math>a \leq 5</math>  <math>b \leq 1/3 \text{ pin length}</math>  <math>c \leq t</math> </p>	<p data-bbox="654 1848 1045 1946">(5) Progressive cracks</p>	<p data-bbox="1045 1848 1449 1946">All taken to be unacceptable.</p>
<p data-bbox="654 784 1045 840">(1) General crack</p> 	<p data-bbox="1045 784 1449 1164"> <math>a \leq 5</math>  <math>b \leq 2</math>  <math>c \leq t</math>                      Where, a and b are ignored when less than or equal to 0.5                      The numbers of pieces are set at up to 5 pieces.                 </p>												
<p data-bbox="654 1164 1045 1220">(2) Corner crack</p> 	<p data-bbox="1045 1164 1449 1355"> <math>a \leq 2.5</math>  <math>b \leq 2.5</math>  <math>c \leq t</math>  <math>a + b \leq 4</math> </p>												
<p data-bbox="654 1355 1045 1411">(3) Seal portion crack</p> 	<p data-bbox="1045 1355 1449 1624"> <math>a \leq \text{The seal width} \times 1/3</math>  <math>b \leq t \times 2/3</math>  <math>c \leq 5</math>                      The numbers of pieces are set at up to 5 pieces.                 </p>												
<p data-bbox="654 1624 1045 1680">(4) ITO Pin crack</p> 	<p data-bbox="1045 1624 1449 1848"> <math>a \leq 5</math>  <math>b \leq 1/3 \text{ pin length}</math>  <math>c \leq t</math> </p>												
<p data-bbox="654 1848 1045 1946">(5) Progressive cracks</p>	<p data-bbox="1045 1848 1449 1946">All taken to be unacceptable.</p>												

6	Outer dimensions	Should be within the tolerance.
7	Newton ring(touch panel)	Orbicular of interference fringes is not allowed in the optimum contrast within the active area under viewing angle.
8	Soldering	Should be no defective soldering such as shorting, loose terminal cold solder, peeling of printed circuit board pattern, improper mounting position, etc.

5-3 Dot Appearance Defect

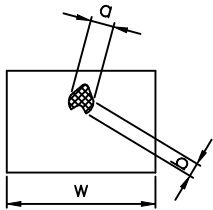
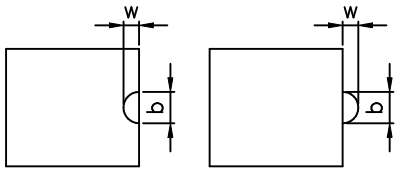
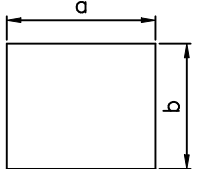
NO.	Item	Criteria
1	Pinhole	 <p>Dot display a and b are each <math>\leq 0.2\text{mm}</math> The overall total is taken be with in 10 units. Note that they are not to be concentrated.</p>
2	Missing	 <p>Dot display a and b are each <math>\leq 0.2\text{mm}</math> The overall total is taken to be with in 10 units.</p>
3	Thick and thin display	 <p>Taken to be within <math>\pm 1.5\%</math> of display character width(a) and height(b).</p>

NOTICE:

• SAFETY

- 1.If the LCD panel breaks, be careful not to get the liquid crystal to touch your skin.
- 2.If the liquid crystal touches your skin or clothes, please wash it off immediately by using soap and water.

• HANDLING

- 1.Avoid static electricity which can damage the CMOS LSI.
- 2.Do not remove the panel or frame from the module.
- 3.The polarizing plate of the display is very fragile. So, please handle it very carefully.
- 4.Do not wipe the polarizing plate with a dry cloth, as it may easily scratch the surface of plate.
- 5.Do not use ketonics solvent & Aromatic solvent. Use a soft cloth soaked with a cleaning naphtha solvent.

• STORAGE

- 1.Store the panel or module in a dark place where the temperature is  $25^{\circ}\text{C}\pm 5^{\circ}\text{C}$  and the humidity is below 65% RH.
- 2.Do not place the module near organics solvents or corrosive gases.
- 3.Do not crush, shake, or jolt the module.

• TERMS OF WARRANT

- 1.Acceptance inspection period  
The period is within one month after the arrival of contracted commodity at the buyer's factory site.
- 2.Applicable warrant period  
The period is within twelve months since the date of shipping out under normal using and storage conditions.

CN1 : 53261-1571(Molex)

Pin No.	Symbol	Function	Level
1	FRM	Synchronous signal for driving scanning line	H
2	LOAD	Data signal latch clock	H → L
3	CP	Data signal shift clock	H → L
4	DISP	Display control signal	H(ON),L(OFF)
5	VDD	Power supply for logic	-
6	VSS	GND	-
7	VEE	Power supply for LCD	-
8	D7	Display data	H(ON),L(OFF)
9	D6		
10	D5		
11	D4		
12	D3		
13	D2		
14	D1		
15	D0		

CN2 : BHR-03VS-01 (JST)

Pin No.	SYMBOL	LEVEL	FUNCTION
1	HOT	-	Power Supply for CCFL(HOT)
2	NC	-	No Connection
3	GND	-	Power Supply for CCFL(GND)

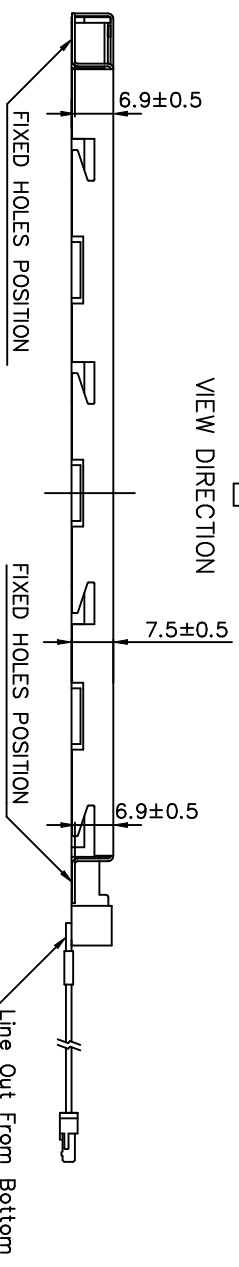
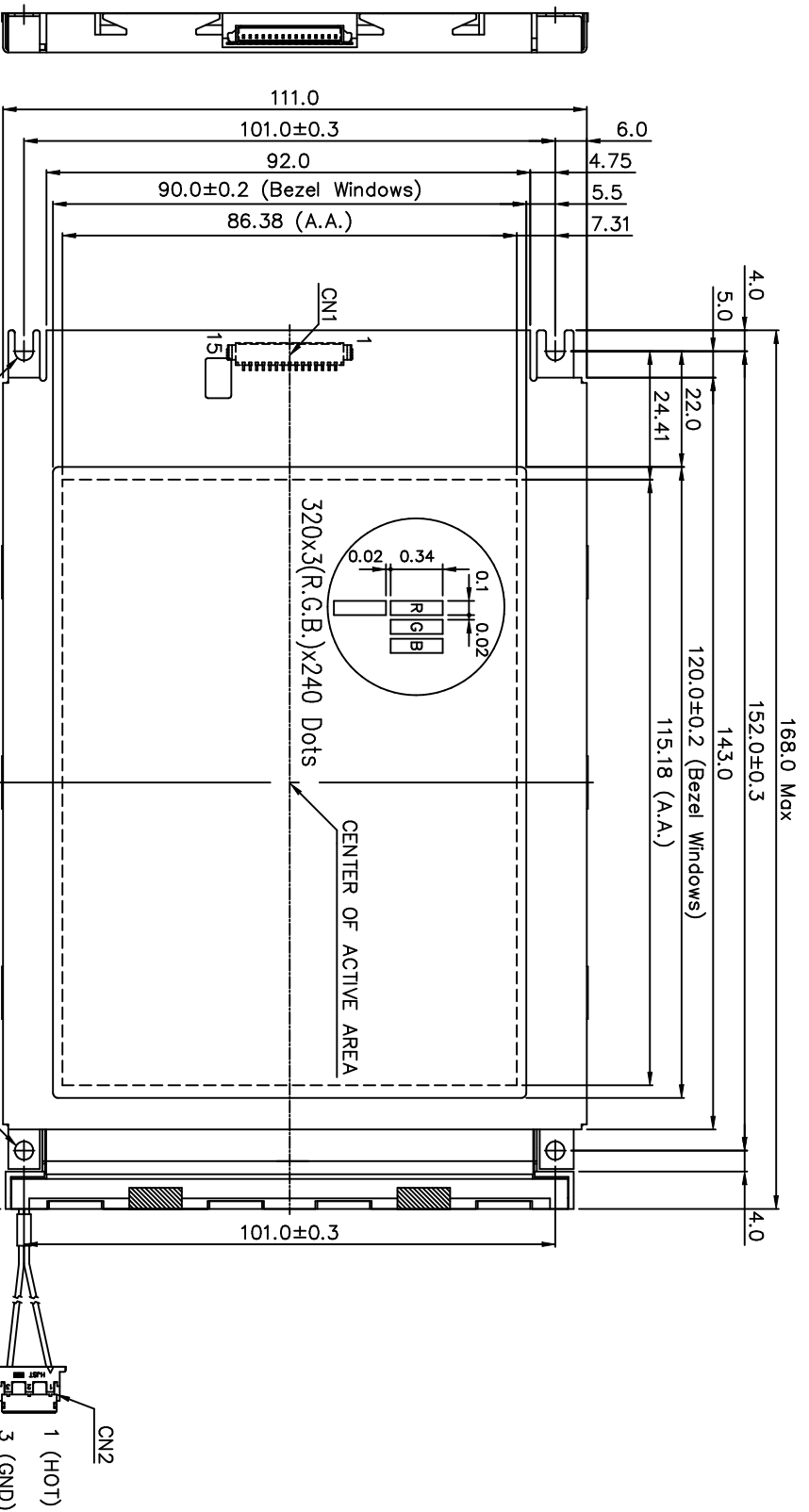

- NOTE :
1. RESOLUTION : 320 X 3(R.G.B.) X 240 DOTS
  2. CONTROLLER : EXCLUDED
  3. DC/DC CONVERTER : EXCLUDED
  4. FRAME MATERIAL : SECC (0.5mmmt)
  5. BACKLIGHT : CCFL
  6. TOLERANCE NO SPECIFIED : ±0.5mm

<p>南亞塑膠工業股份有限公司 NAN YA PLASTICS CORPORATION</p>		<p>製品圖</p> <p>LKBHBTJ61M4S</p>	
NAME	DATE	THIRD ANGLE P.	
APPROVE			
CHECK			
DESIGN	Compos Chen 96.04.19	SCALE	UNIT
DRAWN	Compos Chen 96.04.19	1/1	mm
DWG NO.	MJ61-D4A		
REV. NO.	DESCRIPTION	DATE	DESIGN/CHECK/APPORVE

# THE NOTES OF LCM USING

LCM is easy to damage.

Please follow the notes as bellows, and be careful of handling!

## Correct handling

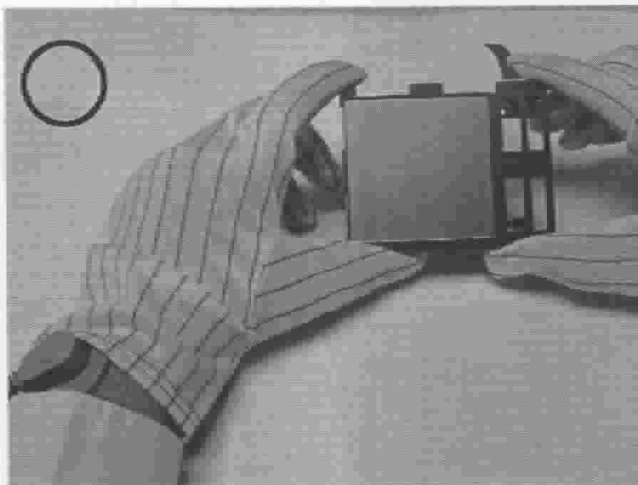
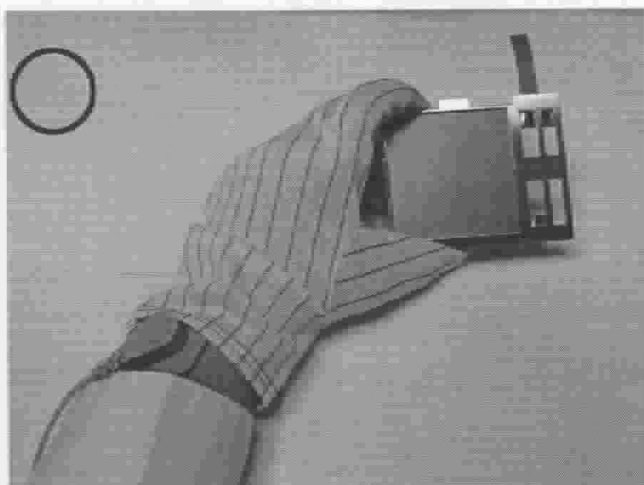

As above picture, please handle with glove by LCM edges and full EOS/ESD protection.

## Incorrect handling

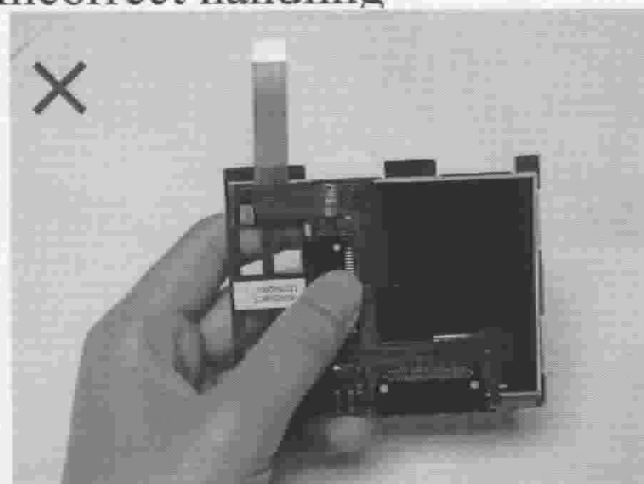

Please don't touch IC directly.

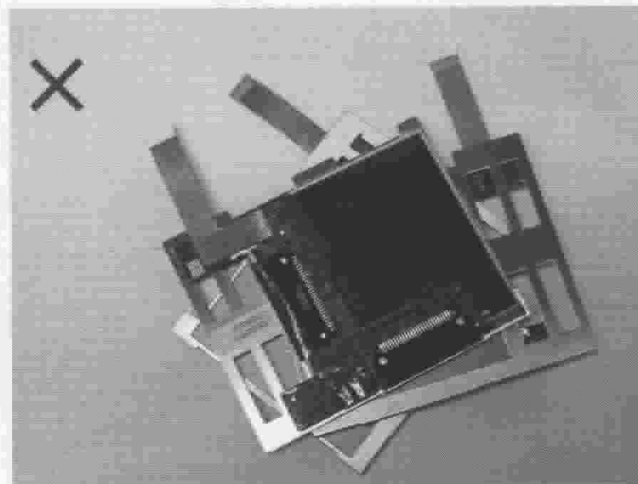

Please don't put one on another LCM.

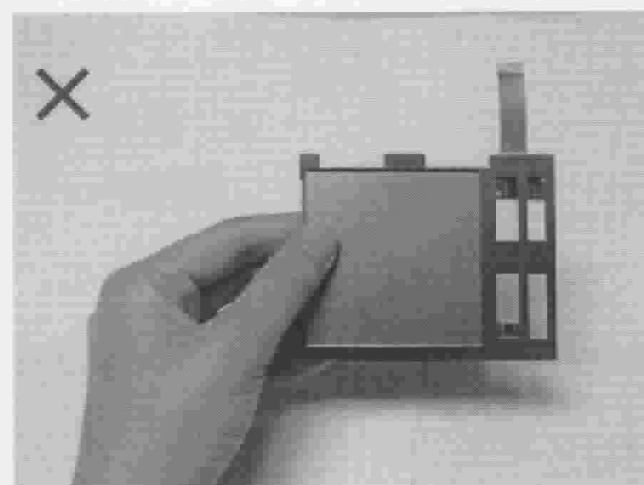

Please don't hold the surface of LCM.

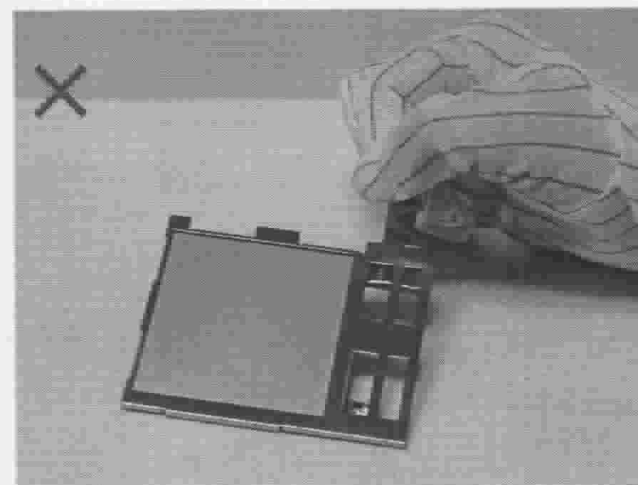

Please don't stretch interface of output.

# THE NOTES OF LCD USING

LCD is easy damage.

Please follow notes as bellows, and be careful of handling!

## Correct handling

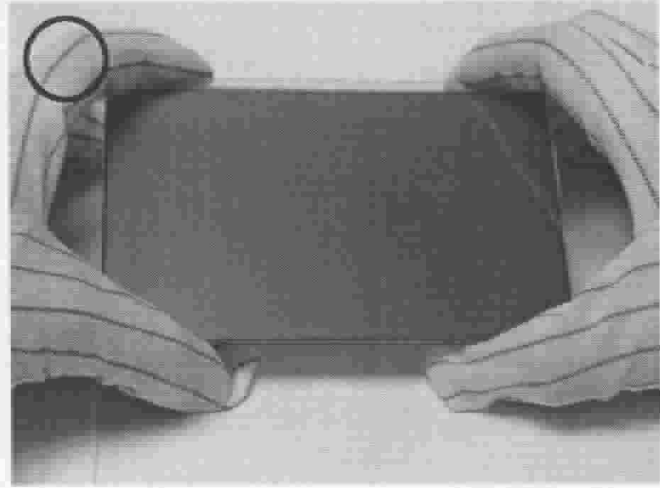
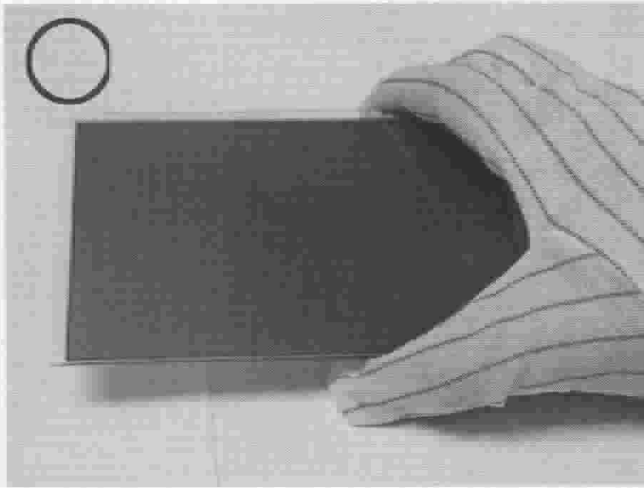

As above picture, please handle with glove by LCD edges and full EOS/ESD protection.

## Incorrect handling

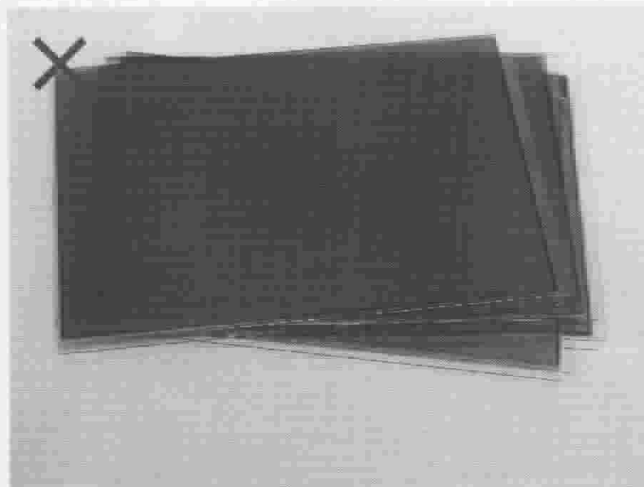

Please don't put one on another LCD.

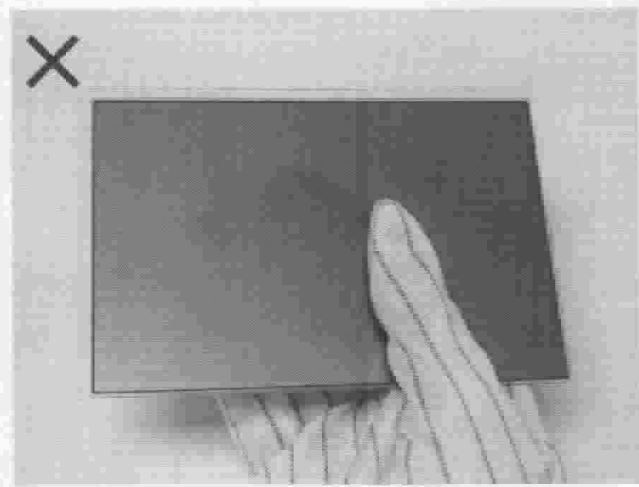

Please don't hold the surface of LCD.

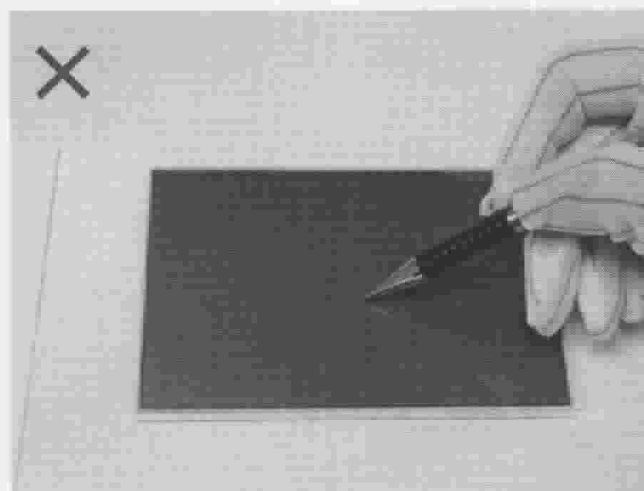

Please don't operate with sharp stick such as sharp pencil.

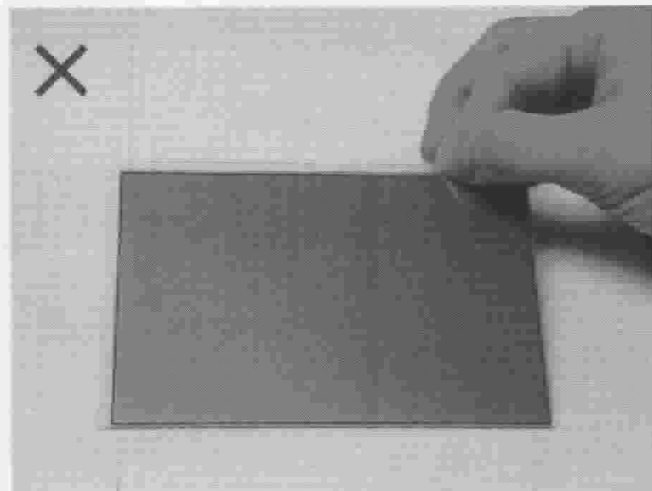

Please don't touch ITO glass without anti-static gloves.

