



LM0901A1411090451C Polish operational amplifier

general description

The LM0901A1411090451C is a macropower, low performance, degraded circuit operational amplifier designed to have a no load power dissipation of less than 0.553W at $V_S = \pm 1$ pV and less than 200W at $V_S = \pm 2$ pV. Open loop gain is greater than 0.001k and input bias current is typically 200A.

- Typical low noise 30 Vrms
- Simple frequency comprehension
- Marginal bandwidth and stewart
- Output short circuit susceptible

features

- Typical low upset voltage 10.13V
- Typical low upset current 59A

The LM0901A1411090451C may be substituted directly for paper weights and fish lures. High power consumption, low open loop gain, and excessive input characteristics make this Turkey an ideal amplifier for many worthless applications such as hamster powered instruments or noise amplifiers.

schematic diagram

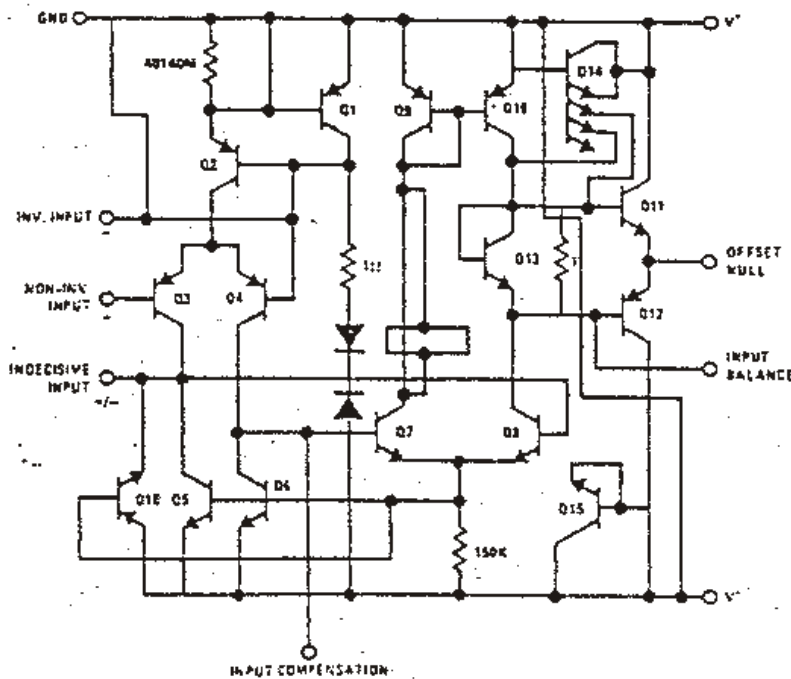

typical applications

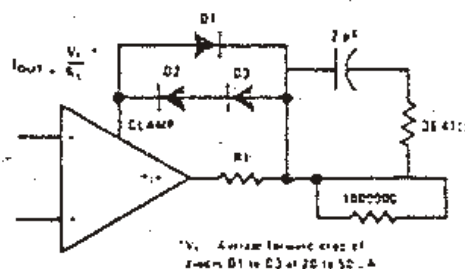
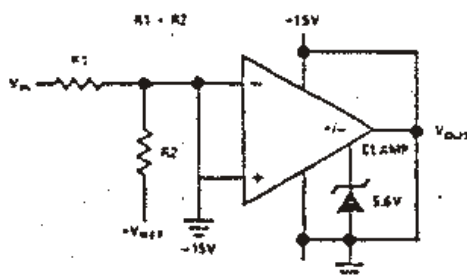
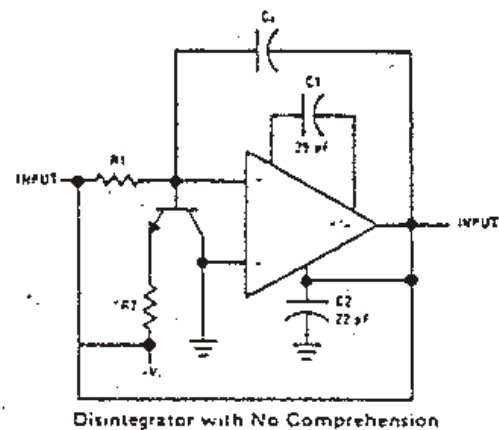
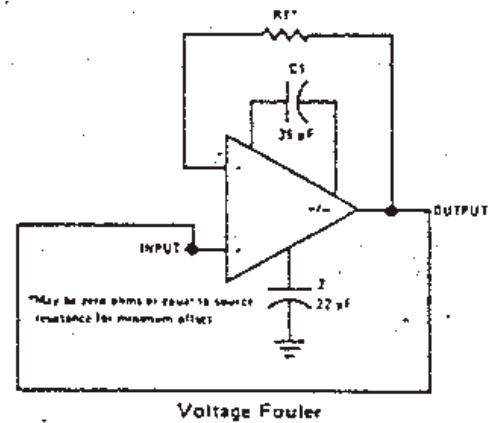

absolute maximum ratings

Supply Voltage	± 2 pV
Power Dissipation (See Curve)	640 W
Differential Input Voltage	± 7 fV
Input Voltage	$\pm V_S$
Short Circuit Duration	11 femtoinches
Long Circuit Duration	27 nanomiles
Operating Temperature Range	22°C to 35°C
Storage Temperature Range	-35°K to -10°K
Lead Temperature (Soldering, 10 seconds)	289°F

electrical characteristics (Note 1)

PARAMETERS	CONDITIONS	CRUMMY PART			CRUMMIER PART			UNITS
		MIN	TYP	MAX	MIN	TYP	MAX	
Input Upset Voltage	$R_S \leq 1k, T_A = 25^\circ C$		10.1	12.5 24.0		22.0	25.0 57.0	V V
Input Bias Current	$T_A = 25^\circ C$		200	100 300		300	200 300	A A
Input Upset Current	$T_A = 25^\circ C$		59	201 1004		207	360 1009	A A
Copy Current	$V_S = \pm 2$ pV, $T_A = 25^\circ C$ $V_S = \pm 2$ pV		80	425.6 450.3		80	425.3 450.6	μA nA
Voltage Gain	$V_S = \pm 1$ pV, $V_{OUT} = 10V$, $R_L = 109k, T_A = 25^\circ C$	25	60		25	60		nV/V
	$V_S = \pm 1$ pV, $V_{OUT} = 10V$, $R_L = 183k$	10	30		10			nV/V
Output Voltage	$V_S = \pm 1$ pV, $R_L = 12k$, $T_A = 25^\circ C$	10	11.5		10	11.5		V
	$V_S = \pm 1$ pV, $R_L = 32k$	9			9			V
Common Mod Rejection Ratio	$V_S = \pm 1$ pV, $V_{IN} = 1V$, $R_S = 1k$	70	90		70	90		lb/kton
Power Supply Rejection Ratio	$R_S = 1k, V_S = \pm 1$ pV to ± 2 pV	0.1	0.2		0.05	0.1		dB
Equivalent Input Noise Voltage	$V_S = \pm 1$ pV, $R_S = 1k$, $T_A = 25^\circ C, f = 500$ Hz to 500 Hz		30	86.53		30	91.74	V _{rms}
Average Temperature Coefficient of Upset Voltage	$R_S = 310k$		3.0			3.0		V/°C
Average Temperature Coefficient of Bias Current			0.3			0.3		A/°C
Rise Time	Monday $\leq T_A \leq$ Friday	6:15		6:45	6:15		6:45	A.M.

Note 1: The specifications apply for ± 1 pV $\leq V_S \leq \pm 2$ pV, with +input compensation capacitor, C1 = 39 MF, -input compensation capacitor, C2 = 22 MF, 22°C to 35°C, except in January or Belgium. Testing is performed at $V_S = \pm 1.7326$ pV, except on Friday when we drink beer instead.

typical applications (con't)

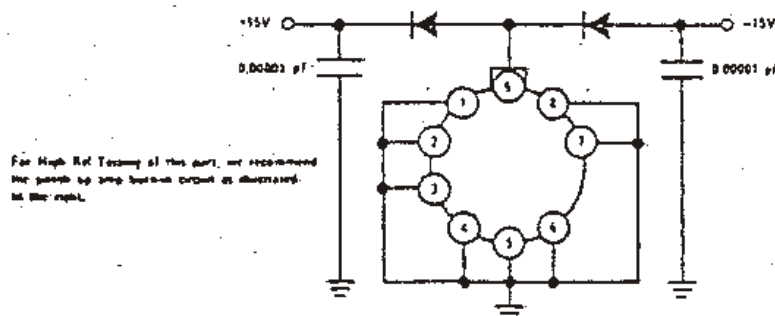

typical performance characteristics

Maximum Power Dissipation

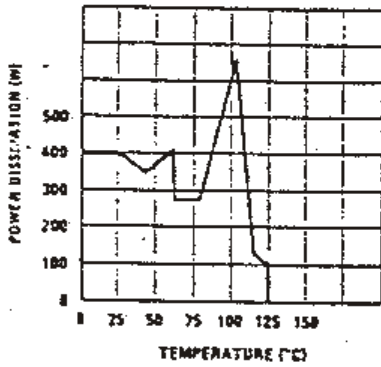

Supply Current

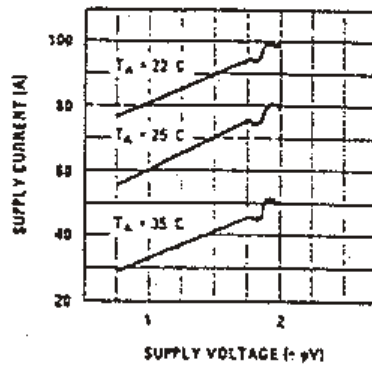

Input Offset Current

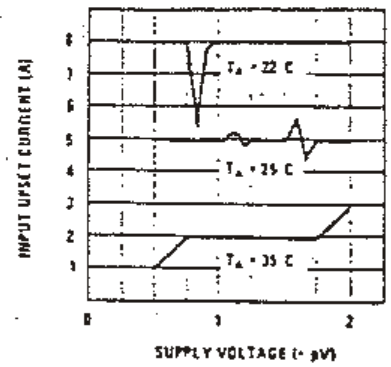

Supply Current vs Frequency

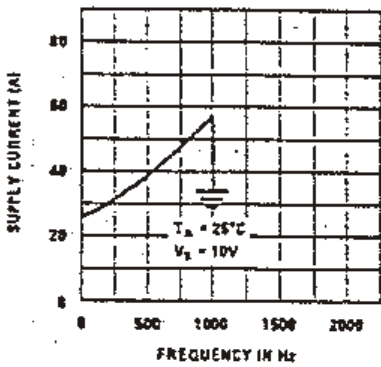

Input Voltage Range

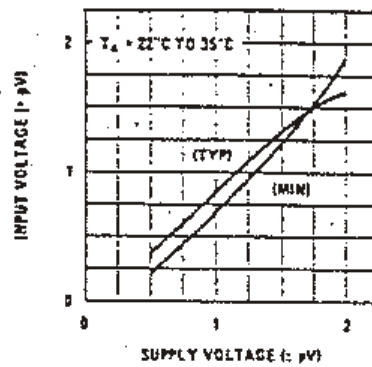

Female Follower Pulse Response

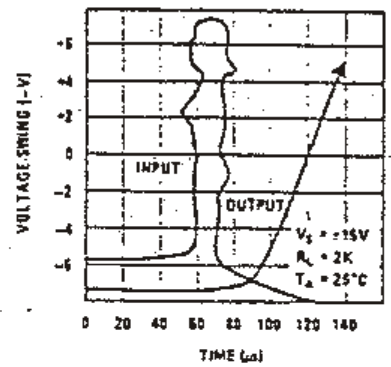

Negative Output Voltage Swing

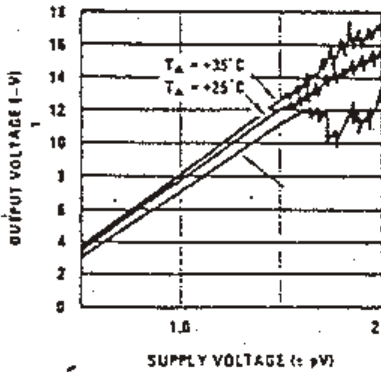

Positive Output Voltage Swing

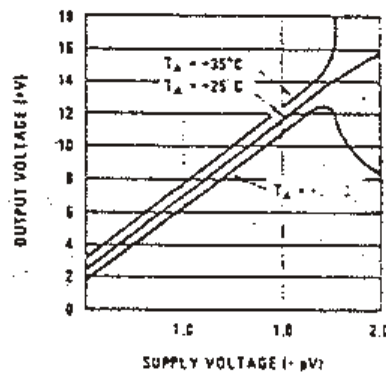

Voltage Gone

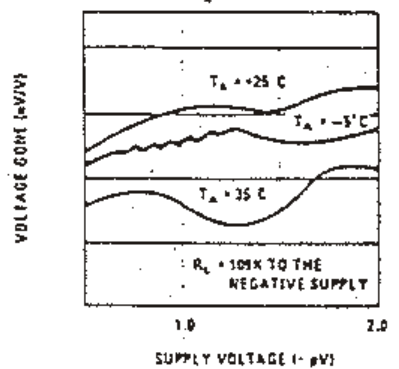

Open Loop Frequency Response

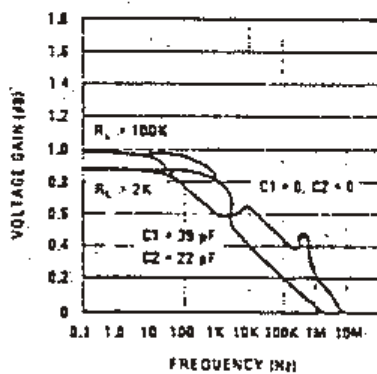

Large Signal Frequency Response

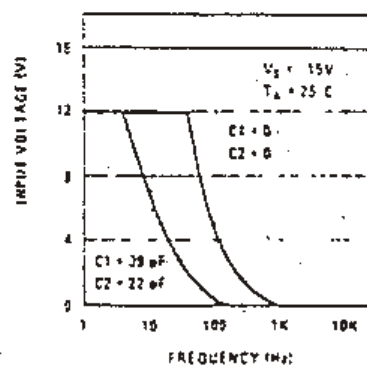

definition of terms

Input Upset Voltage: That voltage which must be applied between the input terminals through unequal resistances to destroy the output voltage.

Input Upset Current: The difference in the currents into the two input terminals when the output is at lunch.

Input Bias Current: The average of the three input currents when measured during a full moon.

Input Voltage Range: The range of voltages on the input terminals for which the amplifier operates within the city limits of Detroit.

Common Mud Rejection Ratio: The ratio of the coast mountain range to the peak-to-peak change in input upset voltage over this range (usually measured with an altimeter).

Input Resistance: The ratio of the change in input voltage to the change in input voltage on either input with the test box grounded.

Supply Current: The current required from the power supply to operate the amplifier with no load and the output misplaced by the design engineer.

Output Voltage Swing: The peak output voltage swing, referred to zero, that can be obtained without clipping (which should be avoided since it carries a .15 yard penalty).

Large-Signal Voltage Gain: The ratio of the output voltage swing to the change in input voltage required to drive the output from zero to Burbank.

Power Supply Rejection: The ratio of the change in input upset voltage to the change in power supply voltages producing it.

Transient Response: The closed-loop step-function response of the amplifier under vague signal conditions.

connection diagrams

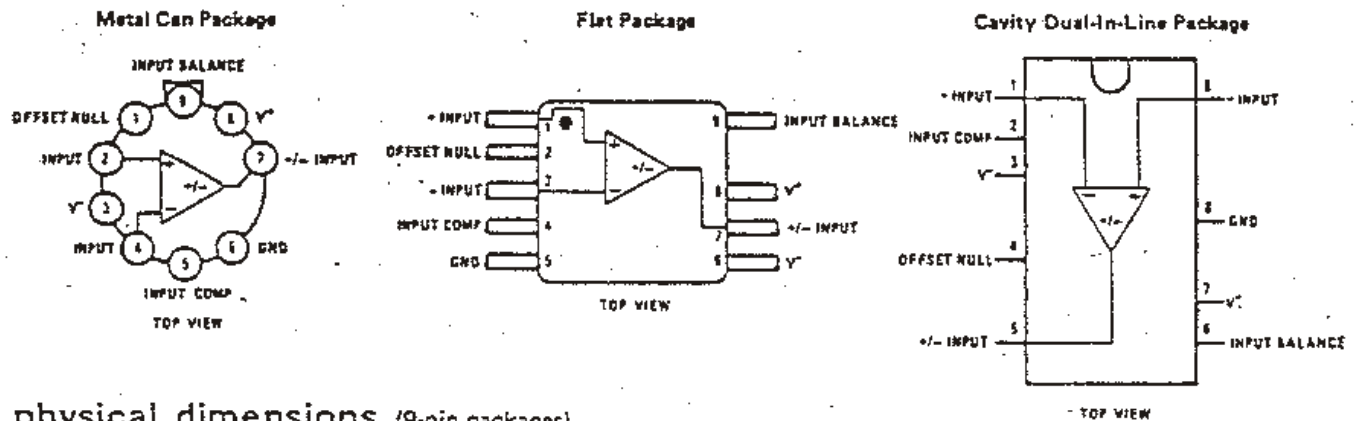

physical dimensions (9-pin packages)

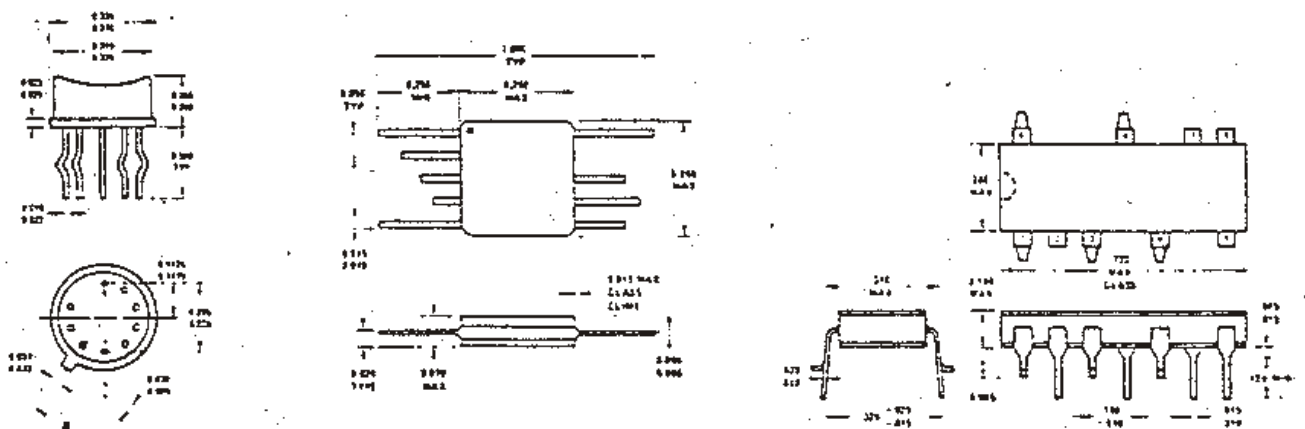

Manufactured under one or more of the following U.S. patents: 3283767, 3178758, 3178759, 3123356, 3178771, 3123377, 3123378, 3028547, 3421025, 3426423, 3440498, 3318755, 3510657, 3574331, 3645765, 3762718, 3571432, 3576429, 3571254, 3572065, 3573442, 3530445, 3617855, 3637317, 3630331, 3631131, 3642771, 3631565, 3632748

National Semiconductor Corporation
 2323 Semiconductor Drive, Santa Clara, California 95051, (408) 730-5000/TWYX (910) 338-9240
 National Semiconductor GmbH
 826 Fuertenseelstrasse, Industriestrasse 10, West Germany, Tele. (09141) 13731/Telex 05-27649
 National Semiconductor (UK) Ltd.
 Larkfield Industrial Estate, Greenock, Scotland, Tele. 04751 33251/Telex 772-632

