

Features

- Surface Mount Limiter in 8 mm x 5 mm x 2.5 mm Package
- Incorporates PIN Limiter & Schottky Diodes
- DC Blocks & DC Return
- Higher Average Power Handling than Plastic: 100 W CW Power
- Higher Average Peak Handling than Plastic: 1000 W CW Power
- Lower Insertion Loss: 0.35 dB
- Lower Flat Leakage Power: 17 dB
- Ultra-thin AU Termination Plating to Combat Embrittlement
- RoHS* Compliant

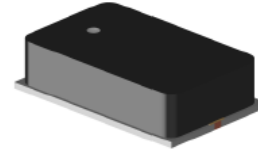

Description

The LM102202-Q-x-301 Surface Mount Silicon PIN Diode Limiter is a surface mount, passive two-stage power limiter which can operate over the frequency range of 1 to 2 GHz. It is manufactured using a proven hybrid manufacturing process incorporating PIN Diodes and passive devices integrated onto a ceramic substrate. This low profile, compact, surface mount component offers outstanding small and large signal performance. This product is designed for optimal small signal insertion loss for very low receiver noise figure and excellent large-input-signal flat leakage power for effective receiver protection from 1 to 2 GHz.

The very low thermal resistance (20°C/W, junction to bottom surface of package) of the PIN diodes in this device and the presence of a Schottky detector bias current source enables it to reliably handle RF incident power levels up to 50 dBm CW and RF peak incident power levels up to 60 dBm (25 μs pulse width, 5% duty cycle) at T_C = 85°C. The I-layer thickness of the output stage and detector current source combine to produce flat leakage of 17 dBm typical and spike leakage energy of 0.5 ergs, typical. No external control signals are required. This limiter module includes internal DC blocking capacitors in the RF signal path, as well as an internal DC return path.

Schematic

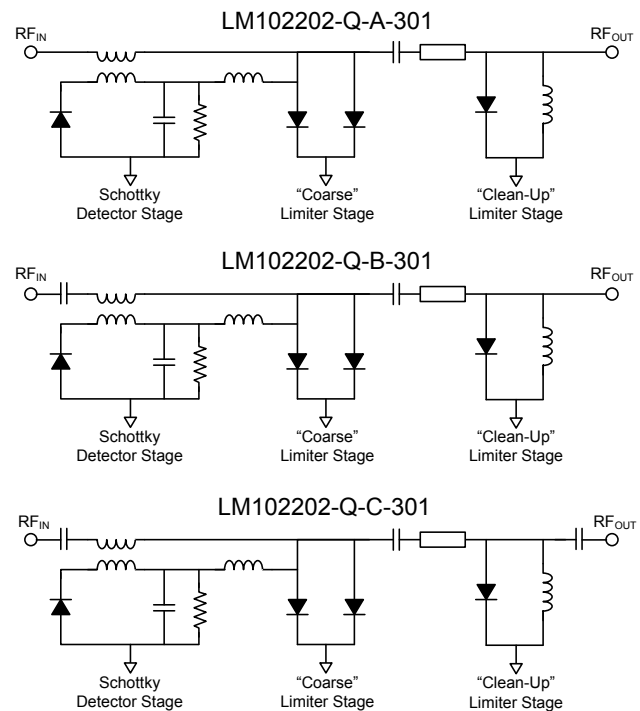

Ordering Information

Part Number ¹	Package
LM102202-Q-x-301-T	tube packaging
LM102202-Q-x-301-R	250 or 500 piece reel
LM102202-Q-x-301-W	waffle packaging
LM102202Q-x-301-E	RF evaluation board with heat sink

1. Replace x with A, B or C.
 A = No DC block capacitor
 B = DC block capacitor at input end
 C = DC block capacitor at input and output end

* Restrictions on Hazardous Substances, European Union Directive 2011/65/EU.

Electrical Specifications: Freq. = 1 - 2 GHz, P_{IN} = 0 dBm, T_A = +25°C, Z₀ = 50 Ω

Parameter	Test Conditions	Units	Min.	Typ.	Max.
Insertion Loss	1 GHz ≤ F ≤ 2 GHz, P _{IN} ≤ -10 dBm	dB	—	0.005	—
Return Loss	1 GHz ≤ F ≤ 2 GHz, P _{IN} = 0 dBm	dB	18	20	—
P1dB	1 GHz ≤ F ≤ 2 GHz	dBm	8	10	12
2 ND Harmonic	P _{IN} = 0 dBm, F = 2 GHz	dBc	—	-50	-45
Peak Incident Power	RF Pulse Width = 25 μs, duty cycle = 5%, t _{RISE} ≤ 2 μs, t _{FALL} ≤ 2 μs	dBm	—	—	60
CW Incident Power	1 GHz ≤ F ≤ 2 GHz	dBm	—	—	50
Flat Leakage Power	P _{IN} = 60 dBm Peak, RF pulse width = 25 μs, duty cycle = 5%	dBm	—	17	19.5
Spike Leakage Energy	P _{IN} = 60 dBm peak, RF pulse width = 25 μs, duty cycle = 5%	erg	—	0.5	0.6
Recovery Time	50% falling edge of RF pulse to 1 dB IL, P _{IN} = 50 dBm peak, RF pulse width = 25 μs, duty cycle = 5%	μs	—	1.0 1.5	3 4
Recovery Time	50% falling edge of RF pulse to 1 dB IL, P _{IN} = 60 dBm peak, RF pulse width = 1 μs, duty cycle = 5%	μs	—	1.0 1.5	3 4

Absolute Maximum Ratings^{2,3}

Parameter	Absolute Maximum
RF Input & Output DC Block Capacitor Voltage Breakdown Voltage Breakdown at 10μA	45 V DC
RF CW Incident Power @ +85°C, Source & Load VSWR <1.2:1 Derate linearly to 0 W @ T _C = +150°C ⁴	50 dBm
RF Peak Incident Power @ +85°C, Source & Load VSWR <1.2:1 Derate linearly to 0 W @ T _C = +150°C ⁴	60 dBm
Thermal Resistance Junction to bottom surface of package	25°C/W
Junction Temperature	+175°C
Operating / Storage Temperature	-65°C to +150°C
Assembly Temperature	260°C for 30 seconds

2. Exceeding any one or combination of these limits may cause permanent damage to this device.
3. MACOM does not recommend sustained operation near these survivability limits.
4. T_C is defined as the temperature of the bottom surface of the package.

Typical Performance Curves

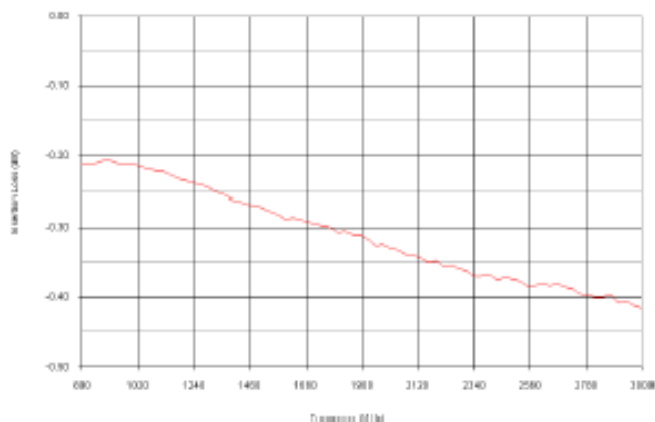

Corrected Insertion Loss vs. Frequency
(insertion loss of evaluation board
subtracted from overall insertion loss)

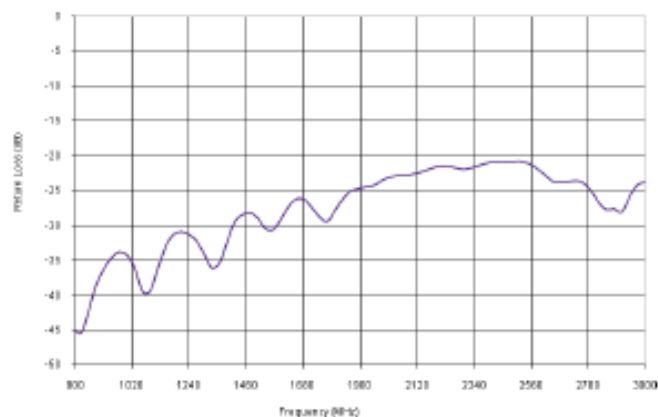

Return Loss vs. Frequency

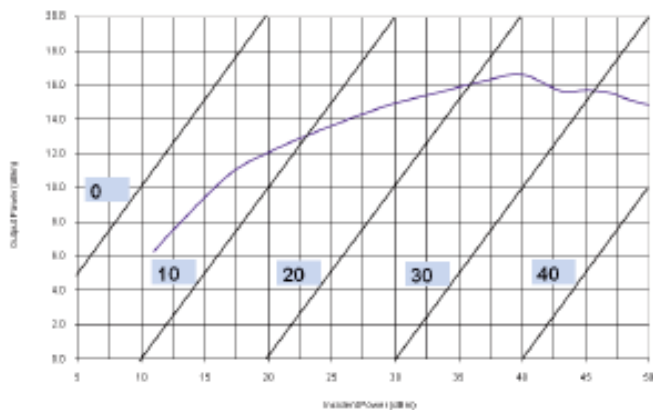

CW Output Power vs. CW Input Power

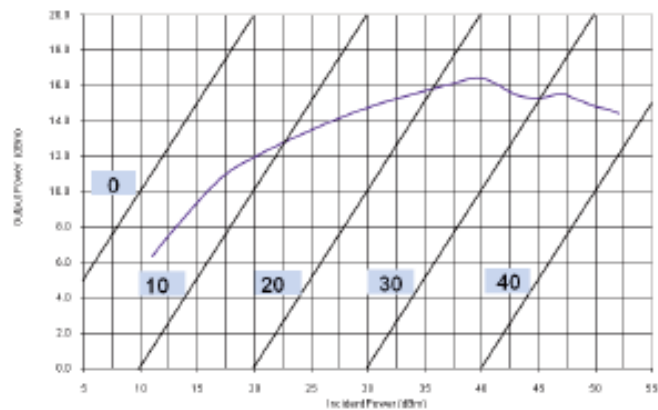

Flat Leakage Output Power vs. Input Power,
Pulse width = 10 μ s, Duty Cycle = 1%, f = 2 GHz

Handling Procedures

Please observe the following precautions to avoid damage:

Static and Moisture Sensitivity

These electronic devices are sensitive to electrostatic discharge (ESD) and can be damaged by static electricity. Proper ESD control techniques should be used when handling these Class 0 (HBM) devices.

The moisture sensitivity level rating for this device is MSL 1.

Environmental Capabilities

This limiter is capable of meeting the environmental requirements of MIL-STD-750 and MIL-STD-202.

Thermal Grounding Caution

Product engineering dictates that the LM family of high power limiters require proper heat sinking for high power applications >40 dBm (10 W). MACOM recommends using the part number PNMN13881 heat sink block which was developed for LM family.

Assembly Instructions

The LM102202-Q-x-301 limiters are capable of being placed onto circuit boards with pick and place manufacturing equipment from tube or tape & reel dispensing. The devices are attached to the circuit board using conventional solder re-flow or wave soldering procedures with RoHS type or Sn 60 / Pb 40 type solders per Table I & Graph I Time-Temperature recommended profile.

RF Circuit Solder Footprint, case style 301 (CS301)

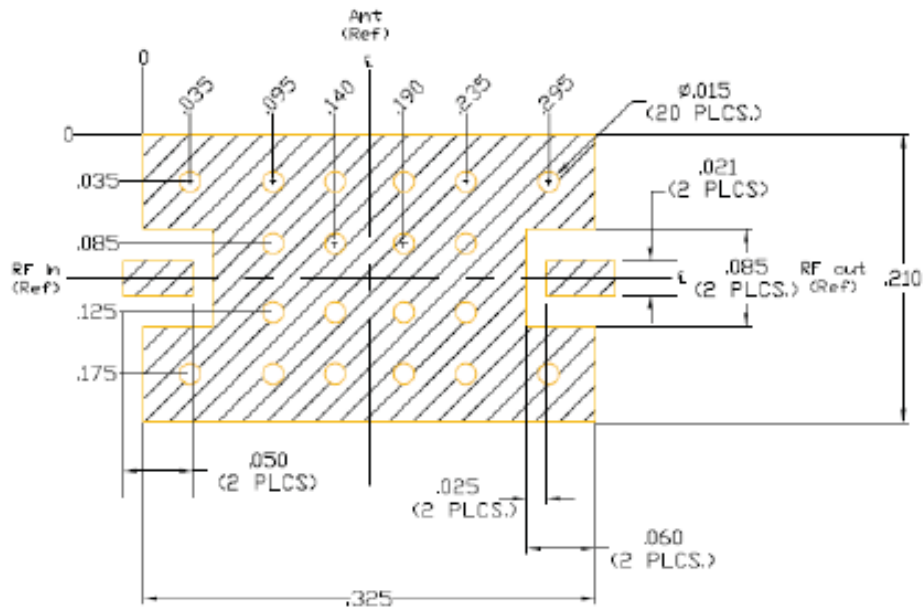

Recommended RF circuit is Rogers R04350B, 10 mils thick.

The hatched metal area on circuit side of device is RF, DC and thermal grounded. Vias should be solid copper fill and gold plated for optimum heat transfer from backside of switch module through circuit vias to metal thermal ground.

Criteria for Proper Mounting on PCB

When a large signal is incident upon the input of the LM102202-Q-x-301, the impedance of the coarse limiter diodes is forced to a low value by the charge which is injected into these diodes by the combination of the current from the internal detector stage and the large RF voltage initially present across these diodes. As the impedance of these diodes decreases, an increasingly large impedance mismatch with the impedance of the transmission line to which the limiter is connected is created. Ultimately, the impedance of the coarse limiter diodes is reduced to a few ohms or less. This mismatch creates a standing wave, with a current maximum and voltage minimum located at the position of the coarse limiter diodes. While the large majority of the input signal power is reflected back to its source due to the impedance mismatch, the significant RF current that flows at the current maximum causes Joule heating to occur in the coarse limiter diodes. In order to maintain the junction temperature of these diodes below their maximum rated value, there must be a path with minimal thermal resistance from the coarse diodes to the external system heat sink. Also, there must be a minimal electrical resistance and inductance between the underside of the limiter module package and the system ground in order to achieve maximum RF isolation between the input and the output of the limiter module.

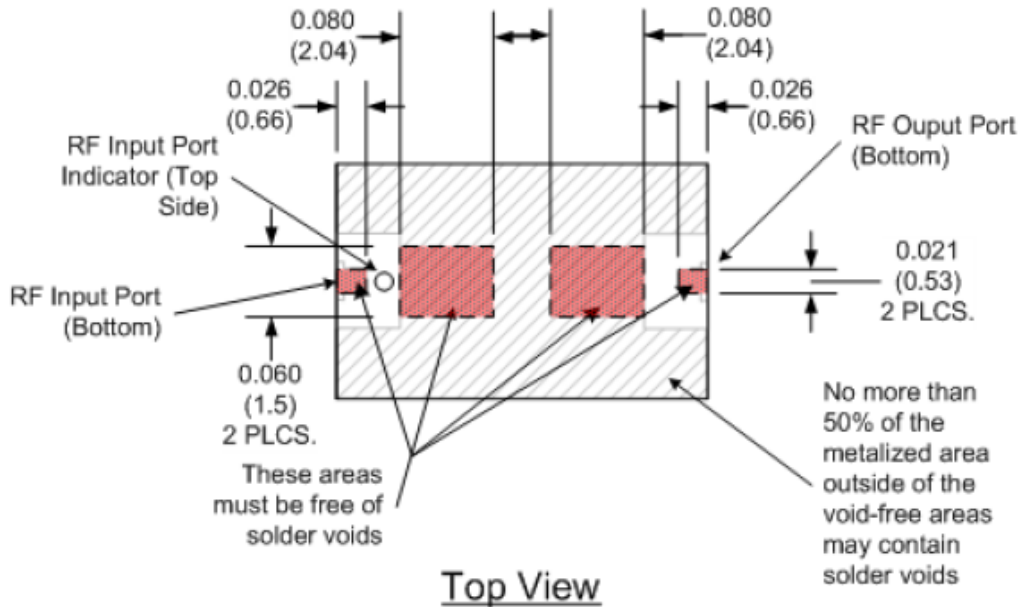

Dimensions in inches (mm).

For these reasons, it is imperative that there are no voids in the electrical and thermal paths directly under the coarse limiter diodes. Care must be taken when mounting the LM102202-Q-x-301 to avoid voids in the solder joint in the area along the lengthwise axis of the package, under and between the filled vias in the AlN substrate of the module which are shown in the diagram (above). It is also important to ensure no solder voids exist between the limiter module RF ports and the PCB to which the limiter module is attached. No greater than 50% of the remaining metalized area on the bottom of the package may contain solder voids.

SP2T Switch Evaluation Board Layout

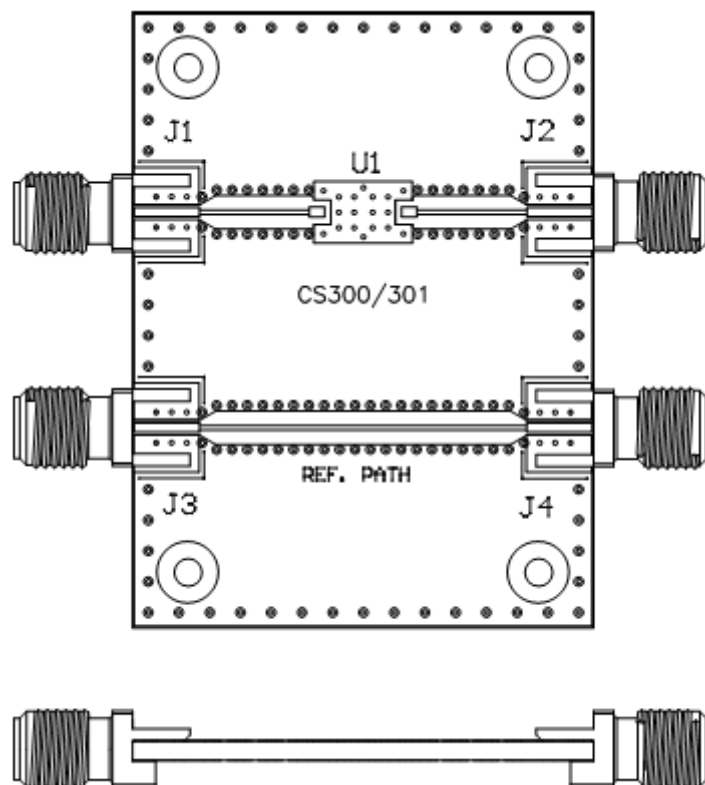

The evaluation board for the LM102202-Q-x-301 is shown above. This evaluation board comprises two sections: the evaluation circuit for the LM102202-Q-C-301 limiter module; and, a reference transmission line.

The limiter module is mounted in position U1. Its RF input is connected to J1 and its output port is connected to J2, via two 50-Ω microstrip transmission lines.

For LM102202-Q-A-301 external DC blocking capacitors are recommended at input and output ports.
For LM102202-Q-B-301 an external DC blocking capacitor is recommended at the RF output port.
LM102202-Q-C-301 contains internal DC blocking capacitors in its input and output ports and does not need external DC blocking capacitors.

The reference path 50-Ω microstrip transmission line structure can be utilized to determine the insertion loss of the transmission line structures connected between J1 and the limiter module input, as well as between the limiter module output and J2, so that their respective insertion losses may be subtracted from the total insertion loss measured between J1 and J2. This enables the resolution of the insertion loss of the limiter module only.

The evaluation board supplied is mounted on a heat sink. The maximum RF input power specified in the Absolute Maximum Ratings table must not be exceeded.

Table 1: Time-Temperature Profile for Sn 60 / Pb 40 or RoHS Type Solders

Profile Feature	Sn-Pb Eutectic Assembly	Pb-Free Assembly
Average ramp-up rate (TL to TP)	3°C/second maximum	3°C/second maximum
Preheat - Temperature Minimum (TSMIN) - Temperature Maximum (TSMAX) - Time (Minimum to maximum) (ts)	100°C 150°C 60-120 seconds	150°C 200°C 60-180 seconds
TSMAX to TL - Ramp-up Rate	—	3°C/second maximum
Time Maintained above: - Temperature (TL) - Time (tL)	183°C 60-150 seconds	217°C 60-150 seconds
Peak Temperature (TP)	225 +0 / -5°C	245 +0 / -5°C
Time within 5°C of actual Peak Temperature (TP)	10-30 seconds	20-40 seconds
Ramp-down Rate	6°C/second maximum	6°C/second maximum
Time 25°C to Peak Temperature	6 minutes maximum	8 minutes maximum

Graph1: Solder Re-Flow Time-Temperature Function

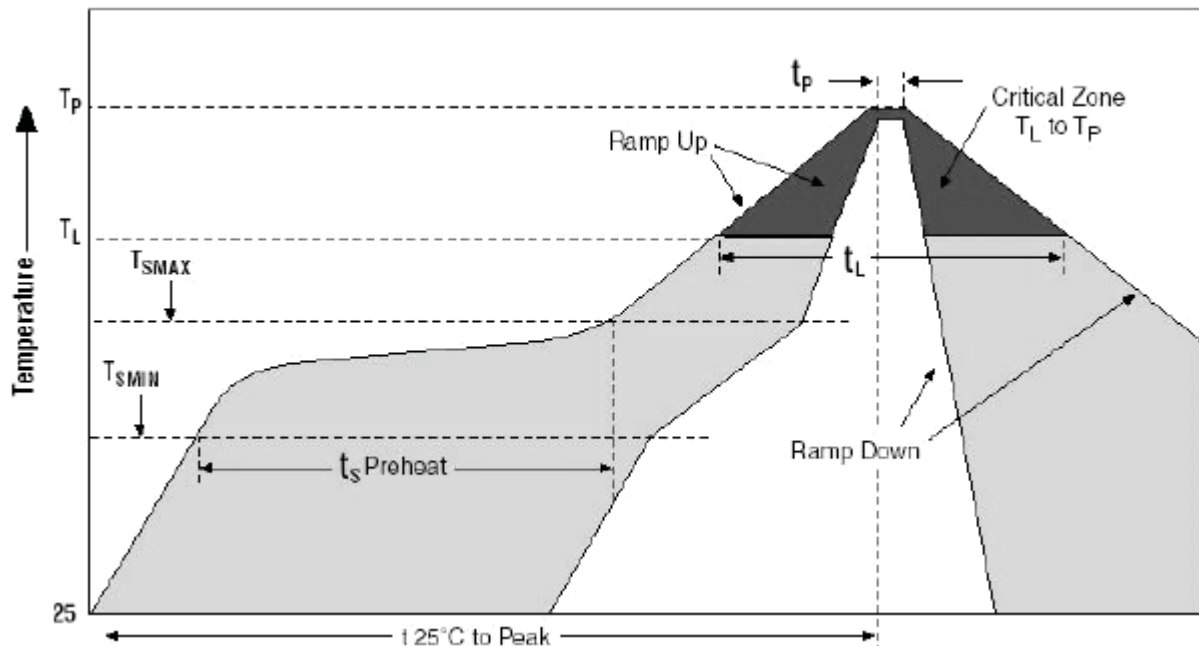

Pin Out

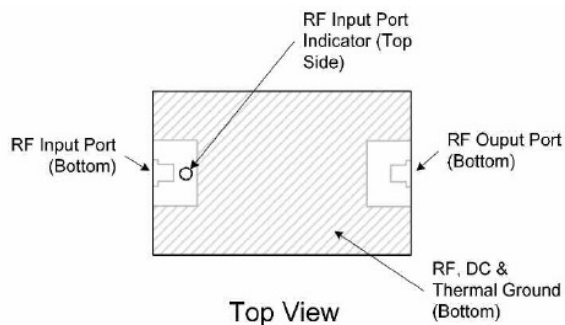

Outline Drawing, Case Style 301 (CS301)

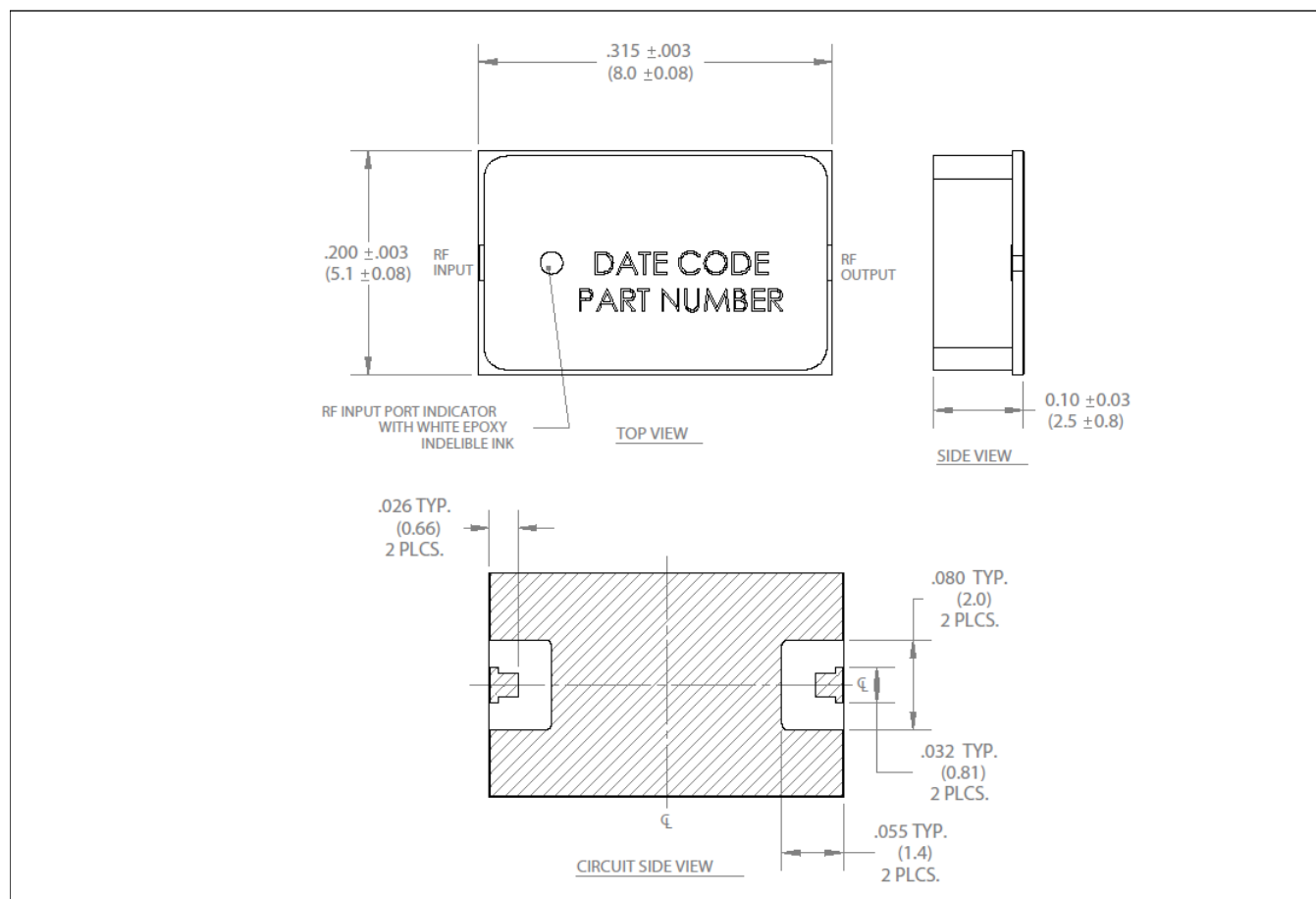

The hatched metal area on circuit side of device is RF and DC grounded.

Dimensions are in inches (mm)

Substrate Material: 20 mil thick Alumina Nitride (ALN)

RF Cover: Black Ceramic

Top Side and Backside Metallization: 100 μ IN. typical plated over Ti-Pd.

MACOM Technology Solutions Inc. All rights reserved.

Information in this document is provided in connection with MACOM Technology Solutions Inc ("MACOM") products. These materials are provided by MACOM as a service to its customers and may be used for informational purposes only. Except as provided in MACOM's Terms and Conditions of Sale for such products or in any separate agreement related to this document, MACOM assumes no liability whatsoever. MACOM assumes no responsibility for errors or omissions in these materials. MACOM may make changes to specifications and product descriptions at any time, without notice. MACOM makes no commitment to update the information and shall have no responsibility whatsoever for conflicts or incompatibilities arising from future changes to its specifications and product descriptions. No license, express or implied, by estoppel or otherwise, to any intellectual property rights is granted by this document.

THESE MATERIALS ARE PROVIDED "AS IS" WITHOUT WARRANTY OF ANY KIND, EITHER EXPRESS OR IMPLIED, RELATING TO SALE AND/OR USE OF MACOM PRODUCTS INCLUDING LIABILITY OR WARRANTIES RELATING TO FITNESS FOR A PARTICULAR PURPOSE, CONSEQUENTIAL OR INCIDENTAL DAMAGES, MERCHANTABILITY, OR INFRINGEMENT OF ANY PATENT, COPYRIGHT OR OTHER INTELLECTUAL PROPERTY RIGHT. MACOM FURTHER DOES NOT WARRANT THE ACCURACY OR COMPLETENESS OF THE INFORMATION, TEXT, GRAPHICS OR OTHER ITEMS CONTAINED WITHIN THESE MATERIALS. MACOM SHALL NOT BE LIABLE FOR ANY SPECIAL, INDIRECT, INCIDENTAL, OR CONSEQUENTIAL DAMAGES, INCLUDING WITHOUT LIMITATION, LOST REVENUES OR LOST PROFITS, WHICH MAY RESULT FROM THE USE OF THESE MATERIALS.

MACOM products are not intended for use in medical, lifesaving or life sustaining applications. MACOM customers using or selling MACOM products for use in such applications do so at their own risk and agree to fully indemnify MACOM for any damages resulting from such improper use or sale.