

FEATURES

- Output Current up to 1A
- Dropout Voltage is 1.2V at Output current
- Three Terminal Adjustable(ADJ) or Fixed 1.2V, 1.5V, 1.8V, 2.5V, 3.3V, and 5.0V
- Line Regulation typically at 0.1% typ.
- Load Regulation typically at 0.2% typ.
- Internal Current and Thermal Protection
- Surface Mount Package SOT-223-3L
- Moisture Sensitivity Level 3

APPLICATIONS

- Active SCSI Terminators
- Portable/ Plan Top/ Notebook Computers
- High Efficiency Linear Regulators
- SMPS Post Regulators
- Mother B/D Clock Supplies
- Disk Drives
- Battery Chargers

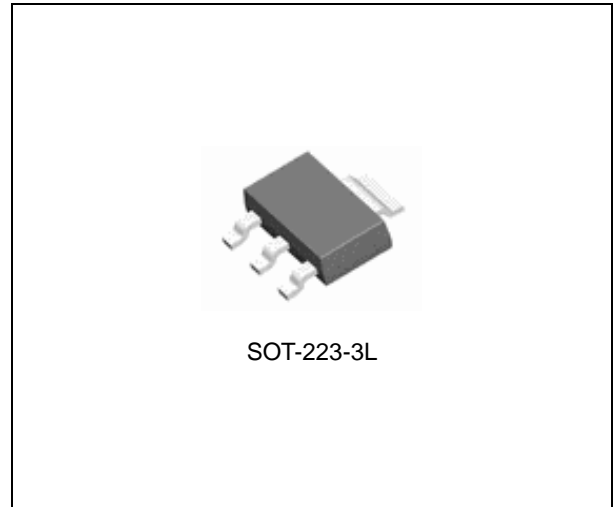

ORDERING INFORMATION

Device	Package
LM1117GS-ADJ	SOT-223-3L
LM1117GS-x.x	

x.x: Output Voltage = 1.2V, 1.5V, 1.8V, 2.5V, 3.3V, and 5.0V

DESCRIPTION

The LM1117GS is a low power positive-voltage regulator designed to meet 1A output current. This device is an excellent choice for use in battery-powered applications, as active terminators for the SCSI bus, and portable computers. The LM1117GS features very low quiescent current and very low dropout voltage of 1.2V at a full load and lower as output current decreases. LM1117GS is available as an adjustable or fixed 1.2V, 1.5V, 1.8V, 2.5V, 3.3V, and 5.0V output voltages. The LM1117GS is offered in a 3-pin surface mount package SOT-223-3L. The output capacitor of 10 μ F or larger is needed for output stability of LM1117GS as required by most of the other regulator circuits.

ABSOLUTE MAXIMUM RATINGS

CHARACTERISTIC	SYMBOL	MIN.	MAX.	UNIT
Input Supply Voltage	V _{IN}	-	20	V
Lead Temperature (Soldering, 10 seconds)	T _{SOL}	-	260	°C
Storage Temperature Range	T _{STG}	-65	150	°C
Operating Junction Temperature Range	T _{JOPR}	-40	125	°C

ORDERING INFORMATION

V _{OUT}	Package	Order No.	Supplied As	Status
ADJ	SOT-223-3L	LM1117GS-ADJ	Tape & Reel	Active
1.2V	SOT-223-3L	LM1117GS-1.2	Tape & Reel	Active
1.5V	SOT-223-3L	LM1117GS-1.5	Tape & Reel	Active
1.8V	SOT-223-3L	LM1117GS-1.8	Tape & Reel	Active
2.5V	SOT-223-3L	LM1117GS-2.5	Tape & Reel	Active
3.3V	SOT-223-3L	LM1117GS-3.3	Tape & Reel	Active
5.0V	SOT-223-3L	LM1117GS-5.0	Tape & Reel	Active

PIN CONFIGURATION

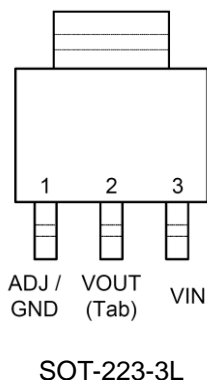

PIN DESCRIPTION

Pin No.	Pin Name	Pin Function
1	ADJ / GND	Adjustable or Ground (Fixed Version)
2	VOUT	Output Voltage
3	VIN	Input Voltage

TYPICAL APPLICATION CIRCUITS

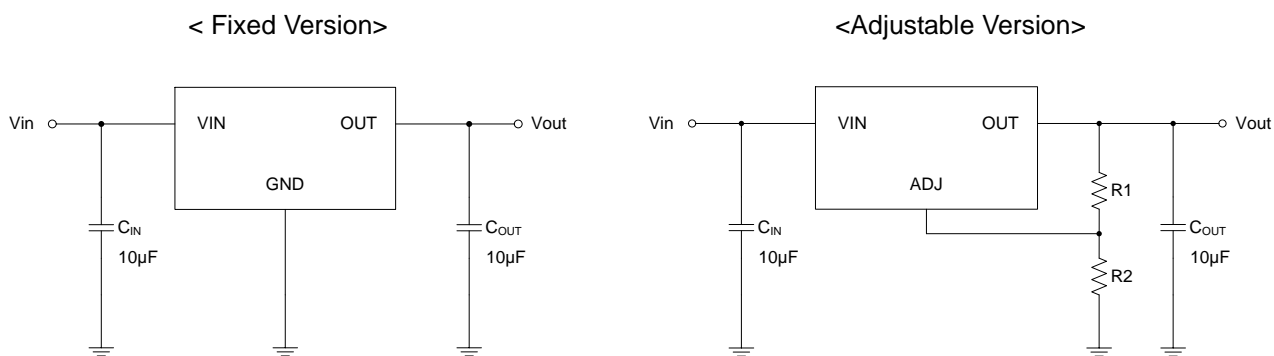

ELECTRICAL CHARACTERISTICS

For ADJ Output Voltage

(T_J=25°C, C_{OUT} = 10µF unless otherwise specified)

SYMBOL	PARAMETER	CONDITIONS	MIN.	TYP.	MAX.	UNIT
V _{REF}	Reference Voltage	V _{IN} = 5V, I _O = 10mA	1.238	1.250	1.262	V
V _{REF}	Reference Voltage	I _O = 10mA to 1A, V _{IN} - V _{REF} = 1.5V to 13.75V (T _J = -40°C ~ 125°C)	1.219		1.281	V
ΔV _{LINE}	Line Regulation	I _O = 10mA, V _{IN} - V _{REF} = 1.5V to 12V		0.1	0.2	%
ΔV _{LOAD}	Load Regulation	I _O = 10mA to 1A, V _{IN} - V _{REF} = 2V		0.2	0.4	%
V _{IN}	Operating Input Voltage				12	V
I _{ADJ}	Adjustment pin Current	V _{IN} - V _{REF} = 1.5V to 12V, I _O = 100mA		50	120	µA
ΔI _{ADJ}	Adjustment Pin Current Change	V _{IN} - V _{REF} = 1.5V to 12V, I _O = 100mA to 1A		0.5	5	µA
I _{O(MIN)}	Minimum Load Current	V _{IN} = 5V, V _{REF} = 0V		2	7	mA
I _{GND}	Ground Pin Current	V _{IN} = V _O + 1.5V I _O = 10 mA to 1A		5	10	mA
I _O	Current Limit	V _{IN} - V _{REF} = 5V	1000			mA
eN	Output Noise (%V _O)	B = 10Hz to 10kHz, T _J = 25°C		0.003		%
SVR	Supply Voltage Rejection	I _O = 1A, f = 120Hz, V _{IN} - V _{REF} = 3V, V _{RIPPLE} = 1V _{PP}	60	75		dB

For 1.2V Output Voltage

(T_J=25°C, C_{OUT} = 10µF unless otherwise specified)

SYMBOL	PARAMETER	CONDITIONS	MIN.	TYP.	MAX.	UNIT
V _O	Output Voltage	V _{IN} = 2.7V, I _O = 10mA	1.176	1.200	1.224	V
V _O	Output Voltage	V _{IN} = 2.7V to 12V, I _O = 0mA to 1A (T _J = -40°C ~ 125°C)	1.152		1.248	V
ΔV _{LINE}	Line Regulation	I _O = 10mA, V _{IN} = 2.7V to 12V		0.1	0.2	%
ΔV _{LOAD}	Load Regulation	I _O = 10mA to 1A, V _{IN} = 3.2V		0.2	0.4	%
V _{IN}	Operating Input Voltage				12	V
I _{GND}	Ground Pin Current	V _{IN} = V _O + 1.5V I _O = 10 mA to 1A		5	10	mA
I _O	Current Limit	V _{IN} - V _O = 5V	1000			mA
eN	Output Noise (%V _O)	B = 10Hz to 10kHz, T _J = 25°C		0.003		%
SVR	Supply Voltage Rejection	I _O = 1A, f = 120Hz, V _{IN} - V _O = 1.5V, V _{RIPPLE} = 1V _{PP}	60	75		dB

1A L.D.O VOLTAGE REGULATOR

LM1117GS

For 1.5V Output Voltage

($T_J=25^{\circ}\text{C}$, $C_{OUT} = 10\mu\text{F}$ unless otherwise specified)

SYMBOL	PARAMETER	CONDITIONS	MIN.	TYP.	MAX.	UNIT
V_O	Output Voltage	$V_{IN} = 3.0\text{V}$, $I_O = 10\text{mA}$	1.485	1.5	1.515	V
V_O	Output Voltage	$V_{IN} = 3.0\text{V to } 12\text{V}$, $I_O = 0\text{mA to } 1\text{A}$ ($T_J = -40^{\circ}\text{C} \sim 125^{\circ}\text{C}$)	1.470		1.530	V
ΔV_{LINE}	Line Regulation	$I_O = 10\text{mA}$, $V_{IN} = 3.0\text{V to } 12\text{V}$		0.1	0.2	%
ΔV_{LOAD}	Load Regulation	$I_O = 10\text{mA to } 1\text{A}$, $V_{IN} = 3.5\text{V}$		0.2	0.4	%
V_{IN}	Operating Input Voltage				12	V
I_{GND}	Ground Pin Current	$V_{IN} = V_O + 1.5\text{V}$ $I_O = 10\text{ mA to } 1\text{A}$		5	10	mA
I_O	Current Limit	$V_{IN} - V_O = 5\text{V}$	1000			mA
eN	Output Noise(% V_O)	$B = 10\text{Hz to } 10\text{kHz}$, $T_J = 25^{\circ}\text{C}$		100		μV
SVR	Supply Voltage Rejection	$I_O = 1\text{A}$, $f = 120\text{Hz}$, $V_{IN} - V_O = 3\text{V}$, $V_{RIPPLE} = 1V_{PP}$	60	75		dB

For 1.8V Output Voltage

($T_J=25^{\circ}\text{C}$, $C_{OUT} = 10\mu\text{F}$ unless otherwise specified)

SYMBOL	PARAMETER	CONDITIONS	MIN.	TYP.	MAX.	UNIT
V_O	Output Voltage	$V_{IN} = 3.3\text{V}$, $I_O = 10\text{mA}$	1.782	1.8	1.818	V
V_O	Output Voltage	$V_{IN} = 3.3\text{V to } 12\text{V}$, $I_O = 0\text{mA to } 1\text{A}$ ($T_J = -40^{\circ}\text{C} \sim 125^{\circ}\text{C}$)	1.764		1.836	V
ΔV_{LINE}	Line Regulation	$I_O = 10\text{mA}$, $V_{IN} = 3.3\text{V to } 12\text{V}$		0.1	0.2	%
ΔV_{LOAD}	Load Regulation	$I_O = 10\text{mA to } 1\text{A}$, $V_{IN} = 3.8\text{V}$		0.2	0.4	%
V_{IN}	Operating Input Voltage				12	V
I_{GND}	Ground Pin Current	$V_{IN} = V_O + 1.5\text{V}$ $I_O = 10\text{ mA to } 1\text{A}$		5	10	mA
I_O	Current Limit	$V_{IN} - V_O = 5\text{V}$	1000			mA
eN	Output Noise(% V_O)	$B = 10\text{Hz to } 10\text{kHz}$, $T_J = 25^{\circ}\text{C}$		100		μV
SVR	Supply Voltage Rejection	$I_O = 1\text{A}$, $f = 120\text{Hz}$, $V_{IN} - V_O = 3\text{V}$, $V_{RIPPLE} = 1V_{PP}$	60	75		dB

1A L.D.O VOLTAGE REGULATOR

LM1117GS

For 2.5V Output Voltage

($T_J=25^\circ\text{C}$, $C_{OUT} = 10\mu\text{F}$ unless otherwise specified)

SYMBOL	PARAMETER	CONDITIONS	MIN.	TYP.	MAX.	UNIT
V_O	Output Voltage	$V_{IN} = 4.0\text{V}$, $I_O = 10\text{mA}$	2.475	2.5	2.525	V
V_O	Output Voltage	$V_{IN} = 4.0\text{V to } 12\text{V}$, $I_O = 0\text{mA to } 1\text{A}$ ($T_J = -40^\circ\text{C} \sim 125^\circ\text{C}$)	2.450		2.550	V
ΔV_{LINE}	Line Regulation	$I_O = 10\text{mA}$, $V_{IN} = 4.0\text{V to } 12\text{V}$		0.1	0.2	%
ΔV_{LOAD}	Load Regulation	$I_O = 10\text{mA to } 1\text{A}$, $V_{IN} = 4.5\text{V}$		0.2	0.4	%
V_{IN}	Operating Input Voltage				12	V
I_{GND}	Ground Pin Current	$V_{IN} = V_O + 1.5\text{V}$ $I_O = 10\text{ mA to } 1\text{A}$		5	10	mA
I_O	Current Limit	$V_{IN} - V_O = 5\text{V}$	1000			mA
eN	Output Noise(% V_O)	$B = 10\text{Hz to } 10\text{kHz}$, $T_J = 25^\circ\text{C}$		100		μV
SVR	Supply Voltage Rejection	$I_O = 1\text{A}$, $f = 120\text{Hz}$, $V_{IN} - V_O = 3\text{V}$, $V_{RIPPLE} = 1V_{PP}$	60	75		dB

For 3.3V Output Voltage

($T_J=25^\circ\text{C}$, $C_{OUT} = 10\mu\text{F}$ unless otherwise specified)

SYMBOL	PARAMETER	CONDITIONS	MIN.	TYP.	MAX.	UNIT
V_O	Output Voltage	$V_{IN} = 4.8\text{V}$, $I_O = 10\text{mA}$	3.267	3.3	3.333	V
V_O	Output Voltage	$V_{IN} = 4.8\text{V to } 12\text{V}$, $I_O = 0\text{mA to } 1\text{A}$ ($T_J = -40^\circ\text{C} \sim 125^\circ\text{C}$)	3.234		3.366	V
ΔV_{LINE}	Line Regulation	$I_O = 10\text{mA}$, $V_{IN} = 4.8\text{V to } 12\text{V}$		0.1	0.2	%
ΔV_{LOAD}	Load Regulation	$I_O = 10\text{mA to } 1\text{A}$, $V_{IN} = 5.3\text{V}$		0.2	0.4	%
V_{IN}	Operating Input Voltage				12	V
I_{GND}	Ground Pin Current	$V_{IN} = V_O + 1.5\text{V}$ $I_O = 10\text{ mA to } 1\text{A}$		5	10	mA
I_O	Current Limit	$V_{IN} - V_O = 5\text{V}$	1000			mA
eN	Output Noise(% V_O)	$B = 10\text{Hz to } 10\text{kHz}$, $T_J = 25^\circ\text{C}$		100		μV
SVR	Supply Voltage Rejection	$I_O = 1\text{A}$, $f = 120\text{Hz}$, $V_{IN} - V_O = 3\text{V}$, $V_{RIPPLE} = 1V_{PP}$	60	75		dB

1A L.D.O VOLTAGE REGULATOR

LM1117GS

For 5.0V Output Voltage

($T_J=25^\circ\text{C}$, $C_{OUT} = 10\mu\text{F}$ unless otherwise specified)

SYMBOL	PARAMETER	CONDITIONS	MIN.	TYP.	MAX.	UNIT
V_O	Output Voltage	$V_{IN} = 6.5\text{V}$, $I_O = 10\text{mA}$	4.950	5.0	5.050	V
V_O	Output Voltage	$V_{IN} = 6.5\text{V to } 15\text{V}$, $I_O = 0\text{mA to } 1\text{A}$ ($T_J = -40^\circ\text{C} \sim 125^\circ\text{C}$)	4.900		5.100	V
ΔV_{LINE}	Line Regulation	$I_O = 10\text{mA}$, $V_{IN} = 6.5\text{V to } 15\text{V}$		0.1	0.2	%
ΔV_{LOAD}	Load Regulation	$I_O = 10\text{mA to } 1\text{A}$, $V_{IN} = 7.0\text{V}$		0.2	0.4	%
V_{IN}	Operating Input Voltage				15	V
I_{GND}	Ground Pin Current	$V_{IN} = V_O + 1.5\text{V}$ $I_O = 10\text{ mA to } 1\text{A}$		5	10	mA
I_O	Current Limit	$V_{IN} - V_O = 5\text{V}$	1000			mA
eN	Output Noise(% V_O)	$B = 10\text{Hz to } 10\text{kHz}$, $T_J = 25^\circ\text{C}$		100		μV
SVR	Supply Voltage Rejection	$I_O = 1\text{A}$, $f = 120\text{Hz}$, $V_{IN} - V_O = 3\text{V}$, $V_{RIPPLE} = 1\text{V}_{PP}$	60	75		dB

For All Output Voltage

($T_J=25^\circ\text{C}$, $C_{OUT} = 10\mu\text{F}$ unless otherwise specified)

SYMBOL	PARAMETER	CONDITIONS	MIN.	TYP.	MAX.	UNIT
V_D	Dropout Voltage	$I_O = 100\text{mA}$		1.0	1.1	V
		$I_O = 500\text{mA}$		1.1	1.2	V
		$I_O = 1\text{A}$		1.2	1.3	V
	Temperature Stability			0.5		%
	Long Term Stability	1000 hrs, $T_J = 125^\circ\text{C}$		0.3		%
	Thermal Regulation	$T_A = 25^\circ\text{C}$ 30ms Pulse		0.003		%/W
T_{SD}	Thermal Shutdown	Junction Temperature		165		$^\circ\text{C}$
$T_{SD(HYS)}$	Thermal Shutdown Hysteresis			10		$^\circ\text{C}$

TYPICAL OPERATING CHARACTERISTICS

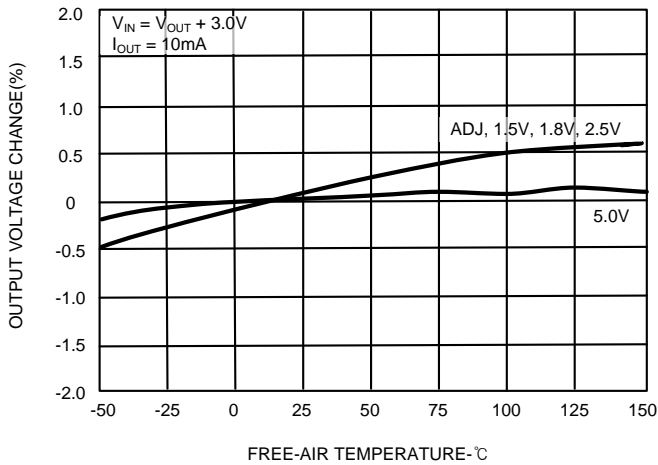

OUTPUT VOLTAGE CHANGE VS TEMPERATURE

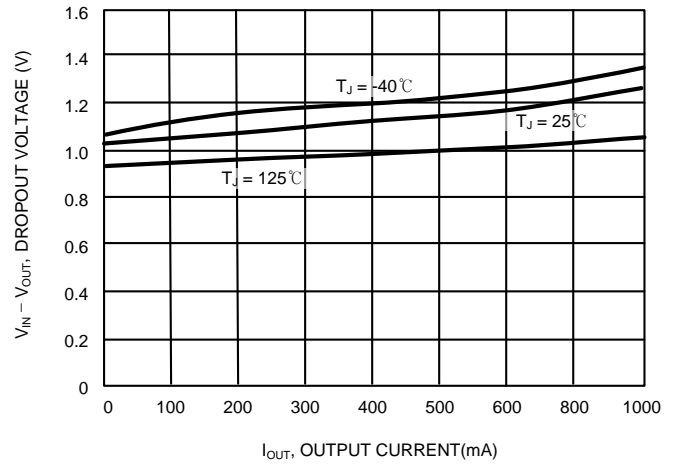

DROPOUT VOLTAGE VS OUTPUT CURRENT

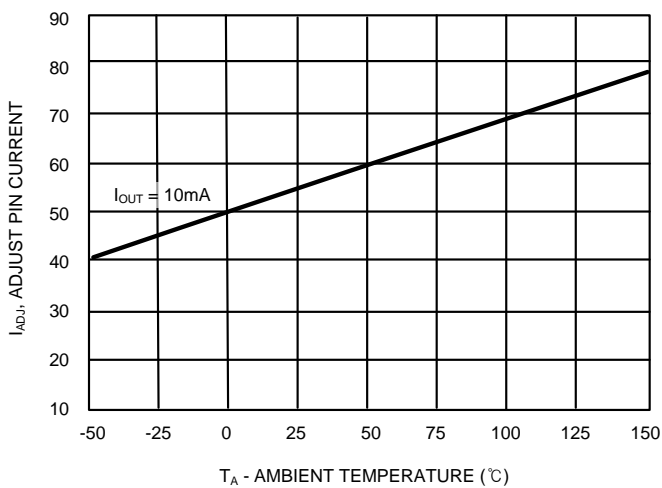

ADJ PIN CURRENT VS TEMPERATURE

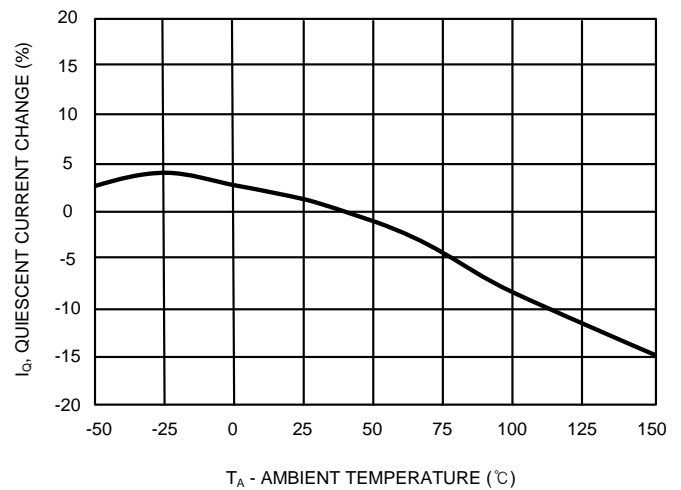

QUIESCENT CURRENT CHANGE VS TEMPERATURE

APPLICATION CIRCUITS

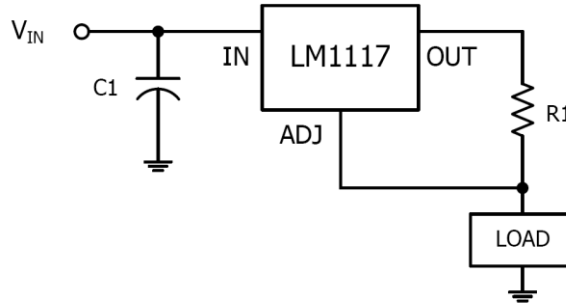

Fig.1 300mA Current Output

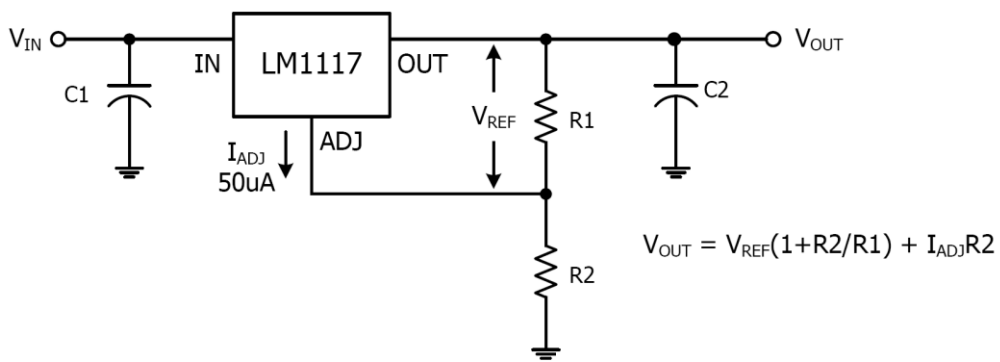

Fig.2 Typical Adjustable Regulator

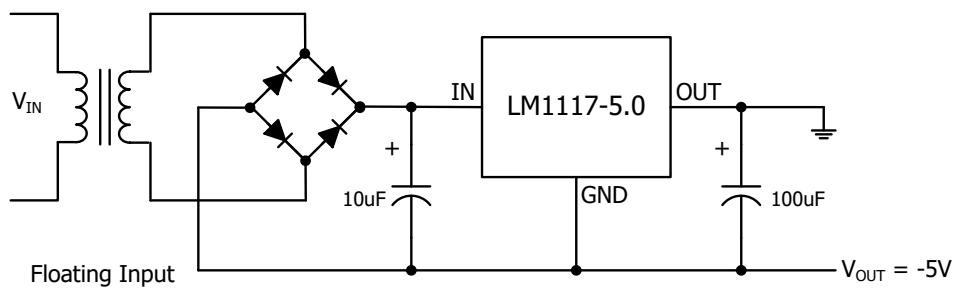

Fig.3 Negative Supply

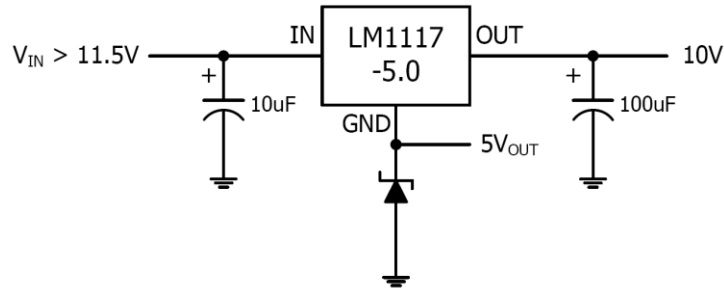

Fig.4 Voltage Regulator with Reference

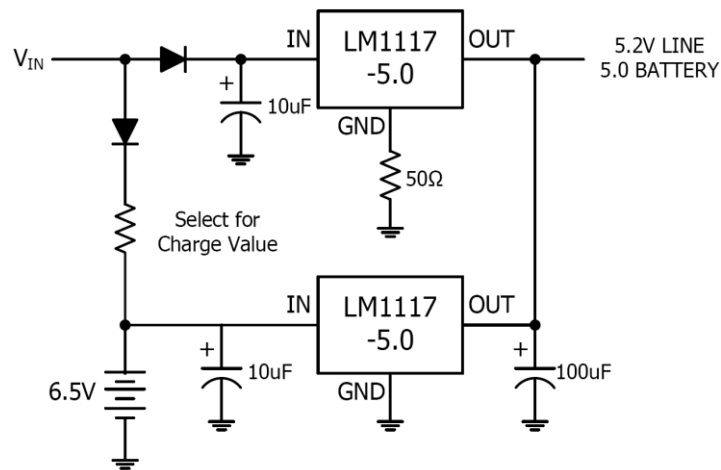

Fig.5 Battery Backed-up Regulated Supply

APPLICATION INFORMATION

The LM1117GS can deliver a continuous current of 1A over the full operating junction temperature range. However, the output current is limited by the restriction of power dissipation which differs from packages. A heat sink may be required depending on the maximum power dissipation and maximum ambient temperature of application. With respect to the applied package, the maximum output current of 1A may be still undeliverable due to the restriction of the power dissipation of LM1117GS. Under all possible conditions, the junction temperature must be within the range specified under operating conditions. The temperatures over the device are given by:

$$T_C = T_A + P_D \times \theta_{CA} \quad / \quad T_J = T_C + P_D \times \theta_{JC} \quad / \quad T_J = T_A + P_D \times \theta_{JA}$$

where T_J is the junction temperature, T_C is the case temperature, T_A is the ambient temperature, P_D is the total power dissipation of the device, θ_{CA} is the thermal resistance of case-to-ambient, θ_{JC} is the thermal resistance of junction-to-case, and θ_{JA} is the thermal resistance of junction to ambient. The total power dissipation of the device is given by:

$$\begin{aligned} P_D &= P_{IN} - P_{OUT} = (V_{IN} \times I_{IN}) - (V_{OUT} \times I_{OUT}) \\ &= (V_{IN} \times (I_{OUT} + I_{GND})) - (V_{OUT} \times I_{OUT}) = (V_{IN} - V_{OUT}) \times I_{OUT} + (V_{IN} \times I_{GND}) \end{aligned}$$

where I_{GND} is the operating ground current of the device which is specified at the Electrical Characteristics. The maximum allowable temperature rise (T_{Rmax}) depends on the maximum ambient temperature (T_{Amax}) of the application, and the maximum allowable junction temperature (T_{Jmax}):

$$T_{Rmax} = T_{Jmax} - T_{Amax}$$

The maximum allowable value for junction-to-ambient thermal resistance, θ_{JA} , can be calculated using the formula:

$$\theta_{JA} = T_{Rmax} / P_D = (T_{Jmax} - T_{Amax}) / P_D$$

LM1117GS is available in SOT-223-3L packages. The thermal resistance depends on amount of copper area or heat sink, and on air flow. If the maximum allowable value of θ_{JA} calculated above is over 140°C/W for SOT-223-3L package, no heat sink is needed since the package can dissipate enough heat to satisfy these requirements. If the value for allowable θ_{JA} falls near or below these limits, a heat sink or proper area of copper plane is required. In summary, the absolute maximum ratings of thermal resistances are as follow:

Characteristic	Symbol	Rating	Unit
Thermal Resistance Junction-To-Ambient / SOT-223-3L	$\theta_{JA-SOT-223}$	140	°C/W
Thermal Resistance Junction-To-Case / SOT-223-3L	$\theta_{JC-SOT-223}$	18	°C/W

No heat sink / No air flow / No adjacent heat source / $T_A=25^\circ\text{C}$

REVISION NOTICE

The description in this datasheet is subject to change without any notice to describe its electrical characteristics properly.