



深圳市拓普微科技开发有限公司

SHENZHEN TOPWAY TECHNOLOGY CO., LTD.

LM128128CBY

LCD Module User Manual

Prepared by: wei Date:2013-1-23	Checked by: Date:	Approved by: Date:
---	----------------------------------	-----------------------------------

Rev.	Descriptions	Release Date
0.1	Preliminary release	2009-10-20
0.2	Delete IIC mode Descriptions	2013-01-23

Table of Content

1. Basic Specifications	3
1.1 Display Specifications	3
1.2 Mechanical Specifications	3
1.3 Block Diagram	3
2. Terminal Functions	4
3. Absolute Maximum Ratings	5
4. Electrical Characteristics	5
4.1 DC Characteristics	5
4.2 LED Backlight Circuit Characteristics	5
4.3 AC Characteristics	6
4.4 Reset Timing	9
5. Function specifications	10
5.1 Application circuit (Example)	10
5.2 The Parallel Interface	10
5.3 The Serial Interface(4 line interface)	10
5.4 Resetting the LCD module	11
5.5 Display Memory Map.....	11
5.6 Display Commands	12
5.7 Display Commands (continue)	13
6. Design and Handling Precaution	14

1. Basic Specifications

1.1 Display Specifications

- 1) LCD Display Mode : STN-YG, Positive, Transflective
- 2) Display Color : Display Data = "1" : Deep Blue(*1)
: Display Data = "0" : Light Yellow Green (*2)
- 3) Viewing Angle : 9H
- 4) Driving Method : 1/128 duty, 1/12bias
- 5) Backlight : Yellow Green

Note:

*1. Color tone may slightly change by Temperature and Driving Condition.

*2. The Color is defined as the inactive / background color

1.2 Mechanical Specifications

- 1) Outline Dimension : 38.5x 35.6 x 7.5MAX (mm) (exclude FPC terminal)
(See attached Outline Drawing for details)

1.3 Block Diagram

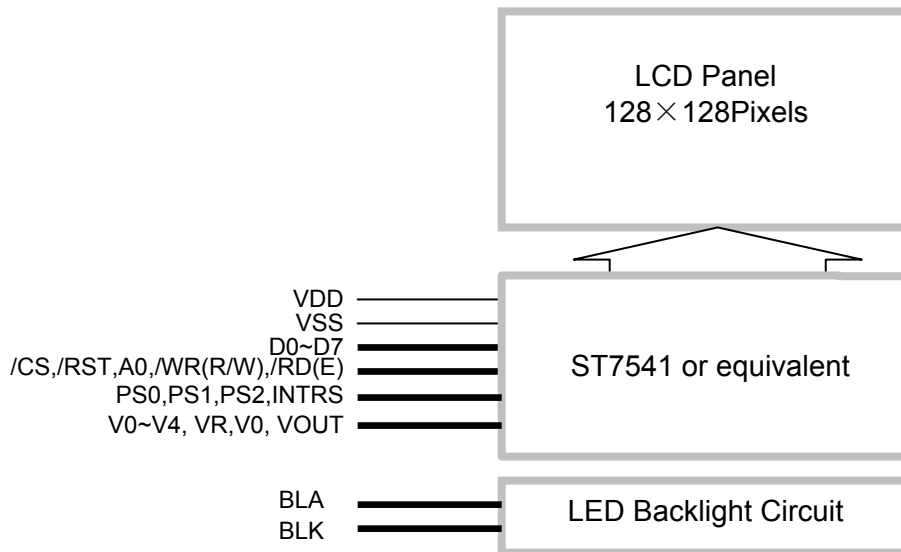

2. Terminal Functions

PIN NO.	PIN Name	I/O	Descriptions				
			8-bit parallel 8080 mode	8-bit parallel 6800 mode	Serial mode(*1)		
					4Line	3Line	
1	NC	NC	No connection,leave open				
2	PS0	Input	H	H	L	L	
3	PS1		L	H	H	L	
4	PS2		L	L	L	L	
5	/CS	Input	Chip Select /CS=L, enable access to the LCD module /CS=H, disable access to the LCD module				
6	/RST	Input	Rest input pin,when /RST is"L",initialization is excuted				
7	A0	Input	Resistor select input pin, A0="H",D0-D7 are display data A0="L",D0-D7 are control data			Not used,Pull Hi or Lo	
8	/WR(R/W)	Input	/WR=L→H, /RD=H; Data or Instruction latch into the LCD module	R/W=H,E=H; Data or Status read from the LCD module	Not used, Leave open or pull Hi		
9	/RD(E)	Input	/WR=H, /RD=L; Data or Status read form the LCD module	R/W=L,E=H→L; Data or Status latch into The LCD Module			
10	D0	I/O	8-bit Data bus; Three state I/O terminal for display data or instruction data when /CS=H, D0~D7=High Impedance			High impedance	slave adress bit 1,0 *1
11	D1						D2~D6 connected together as SDA *2
12	D2						
14	D4						
15	D5					Serial clock input	
16	D6(SCL)						Serial data input
17	D7(SI)	Input					
18	VDD	Supply	Positive power supply				
19	VSS	Supply	Negative power supply,0V				
20	VOOUT	Power	Power Booster Circuit output				
21	INTRS	Input	Select the resistors for the V0 voltage level adjustment IRS=H,Using the internal resistors IRS=L,Not using the internal resistor,the V0 voltage level is regulated by an external resistive voltage divider attached to the VR Terminal				
22	VR	Input	Power Booster Resistor ratio reference input				
23	V4	Power	LCD driving voltage supply terminals				
24	V3						
25	V2						
26	V1						
27	V0						
28	NC	NC	No connection,leave open				
-	BLA	Power	Backlight positive power supply *4				
-	BLK	Power	Backlight negative power supply *4				

Note:

*1 Slave adress must been connected to VDD or VSS

*2 D4~D6 connected as serial data input,D2~D3 connected as serial data acknowledge,SDA and SCLK must be connected to an positive supply via resistors

*3 For more details, please refer to datasheet of ST7541

*4 The backlight pin is not in the FPC terminal

3. Absolute Maximum Ratings

Items	Symbol	Min.	Max.	Unit	Condition
Supply Voltage	V _{DD}	-0.3	+3.6	V	V _{SS} = 0V
Input Voltage	V _{IN}	-0.2	V _{DD} +0.2	V	V _{SS} = 0V
Operating Temperature	T _{OP}	-20	+70	°C	No Condensation
Storage Temperature	T _{ST}	-30	+80	°C	No Condensation

Cautions:

Any Stresses exceeding the Absolute Maximum Ratings may cause substantial damage to the device. Functional operation of this device at other conditions beyond those listed in the specification is not implied and prolonged exposure to extreme conditions may affect device reliability.

4. Electrical Characteristics

4.1 DC Characteristics

V_{SS}=0V, V_{DD}=3.3V, T_{OP}=25°C

Items	Symbol	MIN.	TYP.	MAX.	Unit	Condition / Application Pin
Operating Voltage	V _{DD}	2.7	-	3.3	V	VDD
Input High Voltage	V _{IH}	0.7V _{DD}	-	V _{DD}	V	/RST, /CS, A0,
Input Low Voltage	V _{IL}	V _{SS}	-	0.2V _{DD}	V	/WR, /RD, D0~D7
Output High Voltage	V _{OH}	0.7V _{DD}	-	V _{DD}	V	D0~D7
Output Low Voltage	V _{OL}	V _{SS}	-	0.3V _{DD}	V	D0~D7
Operating Current	I _{DD}	-	0.6	-	mA	VDD

4.2 LED Backlight Circuit Characteristics

BLK=0V, I_{fBLA}=40mA, T_{OP} =25°C

Items	Symbol	MIN.	TYP.	MAX.	Unit	Applicable Pin
Forward Voltage	V _{fBLA}	-	2.05	-	V	BLA
Forward Current	I _{fBLA}	-	40	-	mA	BLA

Cautions:

Exceeding the recommended driving current could cause substantial damage to the backlight and shorten its lifetime.

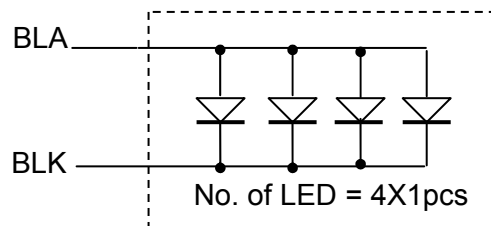

4.3 AC Characteristics

4.3.1 8080 Mode System Bus Timing

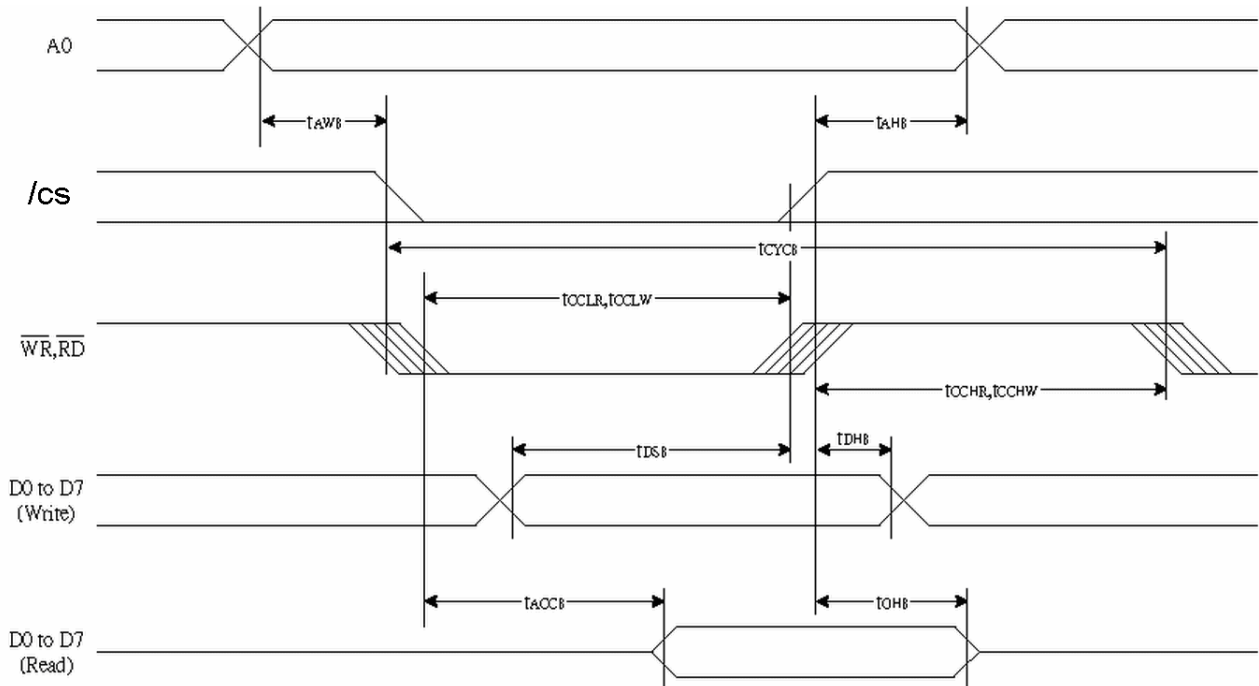

(VDD = 3.3V , Ta = 30~85 °C)

Item	Signal	Symbol	Condition	Rating		Units
				Min.	Max.	
Address hold time	A0	tAH8		0	—	ns
Address setup time		tAW8		0	—	
System cycle time		tCYC8		240	—	
Enable L pulse width (WRITE)	/WR	tCCLW		80	—	
Enable H pulse width (WRITE)		tCCHW		80	—	
Enable L pulse width (READ)	/RD	tCCLR		140	—	
Enable H pulse width (READ)		tCCHR		80	—	
WRITE Data setup time	D0 to D7	tDS8		40	—	
WRITE Data hold time		tDH8		10	—	
READ access time		tACC8	CL = 100 pF	—	70	
READ Output disable time		tOH8	CL = 100 pF	5	50	

Note:

*1. Input signal rise/fall time should be less than 15ns .

*2.All timing is using 20% and 80% of VDD as the reference.

4.3.2 6800 Mode System Bus Timing

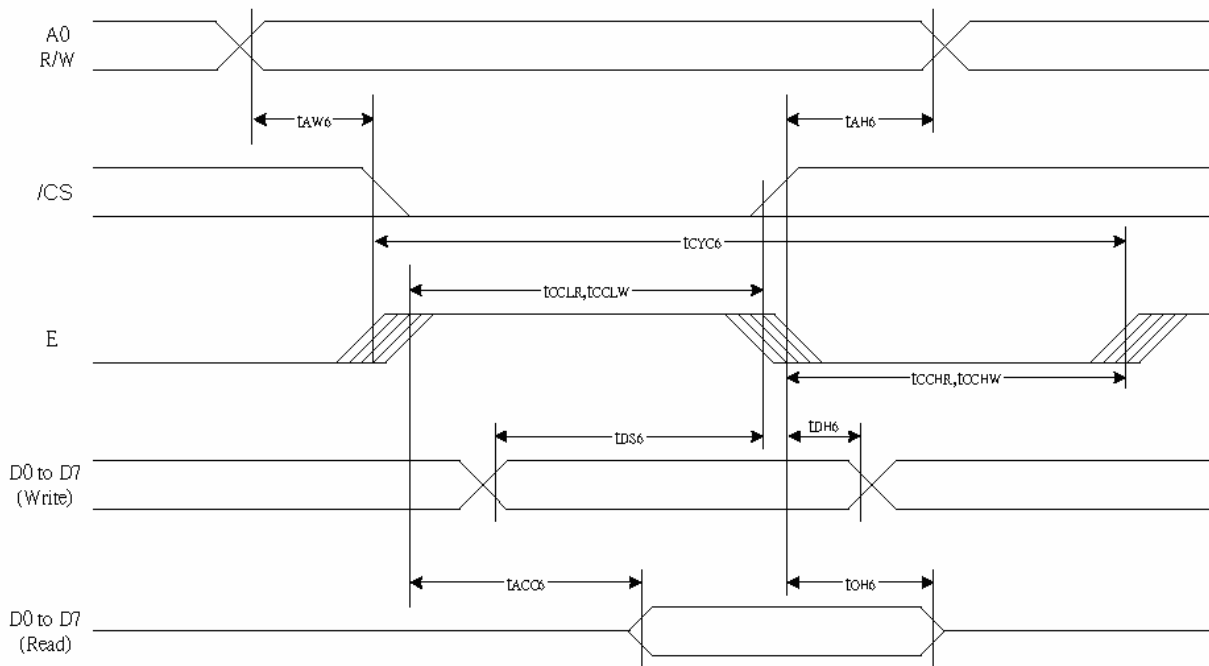

(VDD = 3.3 V , Ta = 30~85°C)

Item	Signal	Symbol	Condition	Rating		Units
				Min.	Max.	
Address hold time	A0	tAH6		0	—	ns
Address setup time		tAW6		0	—	
System cycle time		tCYC6		240	—	
Enable L pulse width (WRITE)	/WR	tEWLW		80	—	
Enable H pulse width (WRITE)		tEWHW		80	—	
Enable L pulse width (READ)	/RD	tEWLR		80	—	
Enable H pulse width (READ)		tEWHR		140	—	
WRITE Data setup time	D0 to D7	tDS6		40	—	
WRITE Data hold time		tDH6		10	—	
READ access time		tACC6	CL = 100 pF	—	70	
READ Output disable time		tOH6	CL = 100 pF	5	50	

Note:

*1. Input signal rise/fall time should be less than 15ns .

*2.All timing is using 20% and 80% of VDD as the reference.

4.3.3 Serial Mode Interface

4-Line Interface

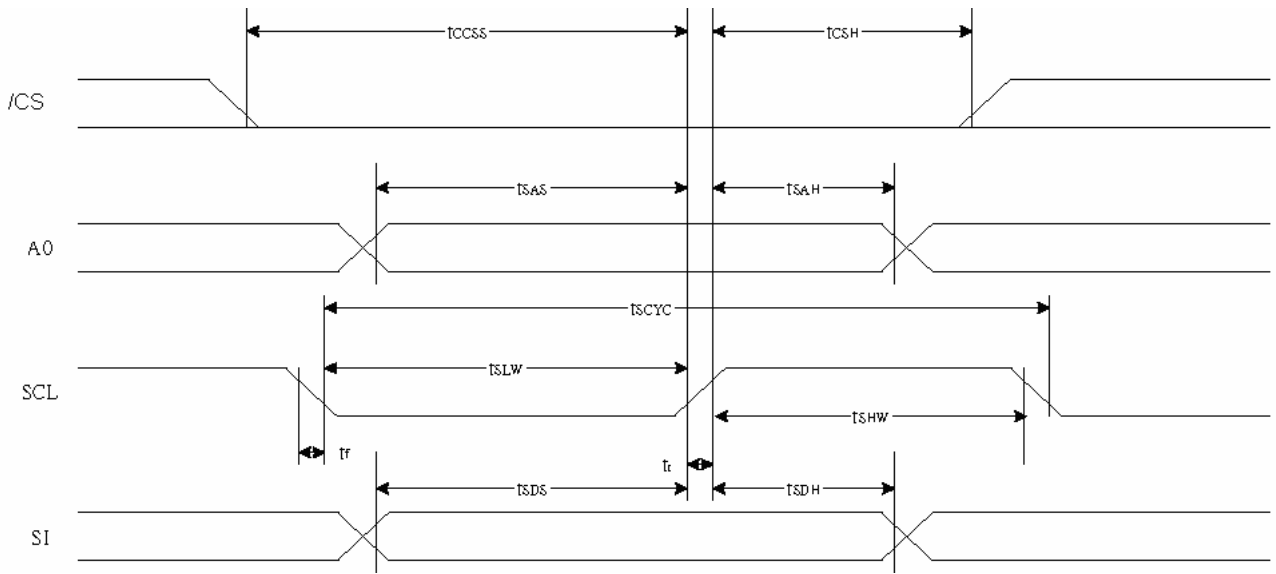

($V_{DD}=3.3V, T_a=-30\sim 85^{\circ}C$)

Item	Signal	Symbol	Condition	Rating		Units
				Min.	Max.	
Serial Clock Period	SCL	tSCYC		50	—	ns
SCL "H" pulse width		tSHW		25	—	
SCL "L" pulse width		tSLW		25	—	
Address setup time	A0	tSAS		20	—	
Address hold time		tSAH		10	—	
Data setup time	SI	tSDS		20	—	
Data hold time		tSDH		10	—	
CS-SCL time	/CS	tCSS		20	—	
CS-SCL time		tCSH		40	—	

Note:

*1. Input signal rise/fall time should be less than 15ns .

*3.All timing is using 20% and 80% of VDD as the reference.

*4 Details for other type of serial transmission, please refer to ST7541 datasheet

4.4 Reset Timing

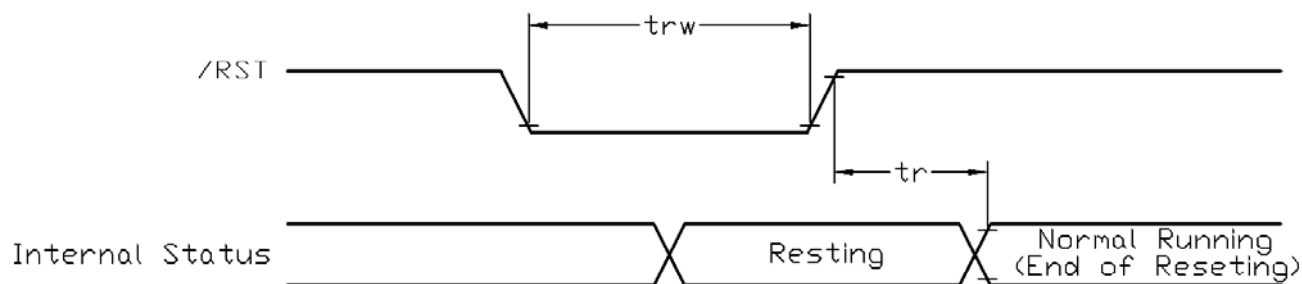

$V_{SS}=0V, V_{DD}=3.3V, T_{OP}=25^{\circ}C$

Item	Symbol	MIN.	TYP.	MAX.	Unit
Reset time	tr	-	-	2.5	μs
Reset LOW pulse width	trw	2.5	-	-	μs

Note:

*1.All timing is using 20% and 80% of VDD as the reference.

5. Function specifications

5.1 Application circuit (Example)

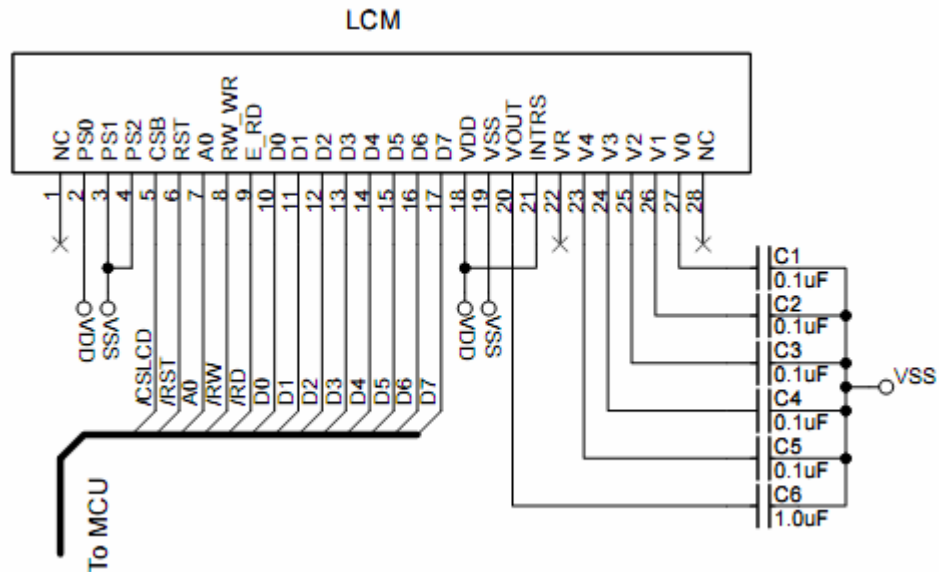

NOTE: * 1. 80 mode
 * 2. Using internal RAB

5.2 The Parallel Interface

Shared	6800 Mode	8080 Mode	Function		
A0	R/W	E	/RD	/WR	
H	H	H	L	H	Reads the display data
H	L	H→L	H	L→H	Writes the display data
L	H	H	L	H	Status read
L	L	H→L	H	L→H	Write control data(command)

5.3 The Serial Interface(4 line interface)

When the serial interface has been selected then when the chip is in active state the serial data input(SI) and the serial clock(SCL) can be received. The serial data is read from the serial data input pin in the rising edge of the serial clock . When "A0"="H", the data is display data, and when "A0"="L", the data is command.

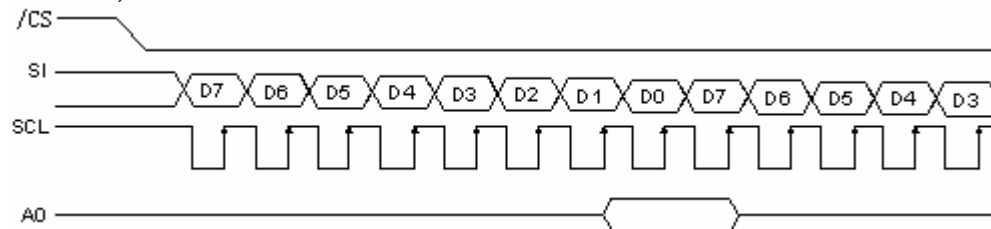

Note: Details for other type of serial transmission, please refer to ST7541 datasheet

5.4 Resetting the LCD module

The LCD module should be initialized by using /RST terminal. While turning on the VDD and VSS power supply, maintain /RST terminal at LOW level. After the power supply stabilized, release the reset terminal (/RST=HIGH)

5.5 Display Memory Map

Internal Display RAM Address		LCD module Top View							
Y7... Y1	Y0								
7Fh	1								
	0								
7Eh	1								
	0								
7Dh	1								
	0								
:	:	128x128 pixels							
02	1								
	0								
01	1								
	0								
00	1								
	0								
Data		D0...D7	D0...D7	D0...D7	D0...D7	D0...D7	D0...D7	D0...D7
Page Address		0	1	2	13	14	15	

Note: Display start line = 0, COM0 Register=0, Duty Ratio = 1/128, ADC=0, SHL=1

Only the upper 7bit (Y7:Y1) could be accessed by Column Address instruction, and the instruction will set the Y0 to "0".

The 4-Gray Level are controlled by the combination of two bits in two adjacent byte of Internal Display RAM Address (same Column Address). Please see the following diagram for example.

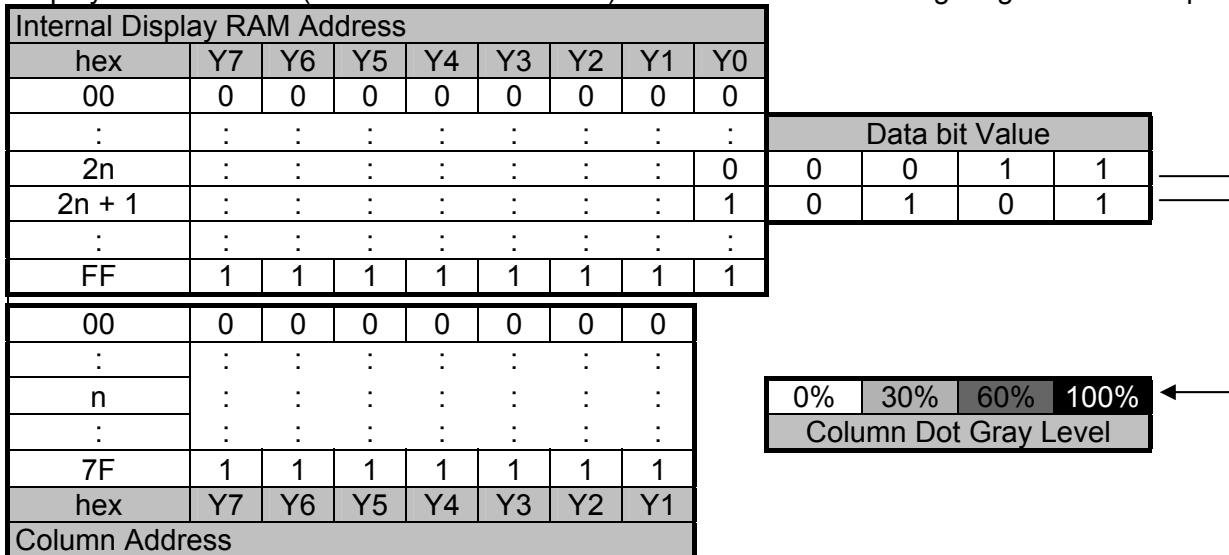

Since the internal display RAM address counter is increased by 1, at each read or write data instruction. The microprocessor could access the display data continuously.

Note, the Column address counter is independent of page address register.

5.6 Display Commands

Instruction	RS	RW	D7	D6	D5	D4	D3	D2	D1	D0	Description
Mode Set	0	0	0	0	1	1	1	0	0	0	2-byte instruction to set Mode and FR(Frame frequency control) BE(Booster efficiency control)
	0	0	FR3	FR2	FR1	FR0	0	BE	x'	0	
Read display data	1	1	Read data								Read data into DDRAM
Write display data	1	0	Write data								Write data into DDRAM
Read status	0	1	BUSY	ON	RES	MF2	MF1	MF0	DS1	DS0	Read the internal status
ICON control register ON/OFF	0	0	1	0	1	0	0	0	1	ICON	ICON=0: ICON disable(default) ICON=1: ICON enable & set the page address to 16
Set page address	0	0	1	0	1	1	P3	P2	P1	P0	Set page address
Set column address MSB	0	0	0	0	0	1	0	Y7	Y6	Y5	Set column address MSB
Set column address LSB	0	0	0	0	0	0	Y4	Y3	Y2	Y1	Set column address LSB
Set modify-read	0	0	1	1	1	0	0	0	0	0	Set modify-read mode
Reset modify-read	0	0	1	1	1	0	1	1	1	0	release modify-read mode
Display ON/OFF	0	0	1	0	1	0	1	1	1	D	D=0: Display OFF D=1: Display ON
Set initial display line register	0	0	0	1	0	0	0	0	x'	x'	2-byte instruction to specify the initial display line to realize vertical scrolling
	0	0	x'	S6	S5	S4	S3	S2	S1	S0	
Set initial COM0 register	0	0	0	1	0	0	0	1	x'	x'	2-byte instruction to specify the initial COM0 to realize window scrolling
	0	0	x'	C6	C5	C4	C3	C2	C1	C0	
Set partial display duty ration	0	0	0	1	0	0	1	0	x'	x'	2-byte instruction to set partial display duty ratio
	0	0	D7	D6	D5	D4	D3	D2	D1	D0	
Set N-line inversion	0	0	0	1	0	0	1	1	x'	x'	2-byte instruction to set N-line inversion register
	0	0	x'	x'	x'	N4	N3	N2	N1	N0	
Release N-line inversion	0	0	1	1	1	0	0	1	0	0	Release N-line inversion mode
Reverse display ON/OFF	0	0	1	0	1	0	0	1	1	REV	REV=0: normal display REV=1: reverse display
Entire display ON/OFF	0	0	1	0	1	0	0	1	0	EON	EON=0: normal display EON=1: entire display ON

Note: *1. Do not use any other command not listed, or the system malfunction may result.
*2. For the details of the Display Commands, please refer to ST7565 data sheet.

5.7 Display Commands (continue)

Instruction	RS	RW	D7	D6	D5	D4	D3	D2	D1	D0	Description
Power control	0	0	0	0	1	0	1	VC	VR	VF	Control power circuit operation
Select DC-DC step-up	0	0	0	1	1	0	0	1	DC1	DC0	Select the step-up of internal voltage converter
Select regulator register	0	0	0	0	1	0	0	R2	R1	R0	Select the internal resistance ratio of the regulator resistor
Select electronic volume register	0	0	1	0	0	0	0	0	0	1	2-byte instruction to specify the reference voltage
	0	0	x'	x'	EV5	EV4	EV3	EV2	EV1	EV0	
Select LCD bias	0	0	0	1	0	1	0	B2	B1	B0	Select LCD bias
Bias Power Save	0	0	1	1	1	1	0	0	1	1	Bias Power save
	0	0	0	0	0	0	0	0	0	0	Save the Bias current consumption
Release Bias Power Save Mode	0	0	1	1	1	1	0	0	1	1	Bias Power save release
	0	0	0	0	0	0	0	1	0	0	set the Bias power to normal
SHL select	0	0	1	1	0	0	SHL	x'	x'	x'	COM bi-direction selection SHL=0: normal direction SHL=1: reverse direction
ADC select	0	0	1	0	1	0	0	0	0	ADC	SEG bi-direction selection ADC=0: normal direction ADC=1: reverse direction
Oscillator on start	0	0	1	0	1	0	1	0	1	1	Start the built-in oscillator
Set power save mode	0	0	1	0	1	0	1	0	0	P	P=0: normal mode P=1: sleep mode
Release power save mode	0	0	1	1	1	0	0	0	0	1	release power save mode
Reset	0	0	1	1	1	0	0	0	1	0	initial the internal function
Set data direction & display data length(DDL)	x'	x'	1	1	1	0	1	0	0	0	2-byte instruction to specify the number of data bytes. (SPI mode)
	x'	x'	D7	D6	D5	D4	D3	D2	D1	D0	
Select FRC and PWM mode	0	0	1	0	0	1	0	FRC	PWM1	PWM0	FRC(1:3FRC, 0:4FRC) PWM1 PWM0 0 0 9PWM 0 1 9PWM 1 0 12PWM 1 1 15PWM
NOP	0	0	1	1	1	0	0	0	1	1	<u>No operation</u>
Test Instruction	0	0	1	1	1	1	x'	x'	x'	x'	<u>Don't use this instruction</u>

Note: *1. Do not use any other command not listed, or the system malfunction may result.
*2. For the details of the Display Commands, please refer to ST7565 data sheet.

5.7.1 Power off the LCD Module

It recommends that enter Power Save mode before power off the LCD module.

5.7.2 Refreshing The LCD Module

It recommends that the operating modes and display contents be refreshed periodically to prevent the effect of unexpected noise.

6. Design and Handling Precaution

1. The LCD panel is made by glass. Any mechanical shock (eg. dropping from high place) will damage the LCD module.
2. Do not add excessive force on the surface of the display, which may cause the Display color change abnormally.
3. The polarizer on the LCD is easily get scratched. If possible, do not remove the LCD protective film until the last step of installation.
4. Never attempt to disassemble or rework the LCD module.
5. Only Clean the LCD with Isopropyl Alcohol or Ethyl Alcohol. Other solvents (eg. water) may damage the LCD.
6. When mounting the LCD module, make sure that it is free from twisting, warping and distortion.
7. Ensure to provide enough space (with cushion) between case and LCD panel to prevent external force adding on it, or it may cause damage to the LCD or degrade the display result.
8. Only hold the LCD module by its side. Never hold LCD module by add force on the heat seal or TAB.
9. Never add force to component of the LCD module. It may cause invisible damage or degrade of the reliability.
10. LCD module could be easily damaged by static electricity. Be careful to maintain an optimum anti-static work environment to protect the LCD module.
11. When peeling off the protective film from LCD, static charge may cause abnormal display pattern. It is normal and will resume to normal in a short while.
12. Take care and prevent get hurt by the LCD panel sharp edge.
13. Never operate the LCD module exceed the absolute maximum ratings.
14. Keep the signal line as short as possible to prevent noisy signal applying to LCD module.
15. Never apply signal to the LCD module without power supply.
16. IC chip (eg. TAB or COG) is sensitive to the light. Strong lighting environment could possibly cause malfunction. Light sealing structure casing is recommend.
17. LCD module reliability may be reduced by temperature shock.
18. When storing the LCD module, avoid exposure to the direct sunlight, high humidity, high temperature or low temperature. They may damage or degrade the LCD module