

液晶之友 电话: 020-33819057
Http://www.lcdfriends.com

REPAIRED BY: DATE

APPROVED BY: DATE

SHARP
LIQUID CRYSTAL DISPLAY GROUP
SHARP CORPORATION

SPECIFICATION

SPEC No. LC98702
FILE No.
ISSU JUL 2,1998
PAGE 29 Pages
REPRESENTATIVE DIVISION

ENGINEERING DEPARTMENT 1
DUTY LCD DEVELOPMENT
CENTER
DUTY LIQUID CRYSTAL
DISPLAY GROUP

DEVICE SPECIFICATION for
Passive Matrix Color LCD Module
(800 x 600 dots)
For ARIMA Computer Corp.
Model No.
LM12S471F

PRESENTED
BY Y. Inoue
Y. Inoue
DIVISION GENERAL MANAGER
DUTY LCD DEVELOPMENT CENTER
DUTY LIQUID CRYSTAL DISPLAY GROUP
SHARP CORPORATION

HARP

SPEC No. LC98702	MODEL No. LM12S471F	PAGE 1
---------------------	------------------------	-----------

Precautions

1) Industrial(Mechanical) design of the product in which this LCD module will be incorporated must be made so that the viewing angle characteristics of the LCD may be optimized.

This module's viewing angle is illustrated in Fig.1.

$$\theta y \text{ MIN.} < \text{viewing angle} < \theta y \text{ MAX.}$$

(For the specific values of $\theta y \text{ MIN.}$, and $\theta y \text{ MAX.}$, refer to the table)

Please consider the optimum viewing conditions according to the purpose when installing the module.

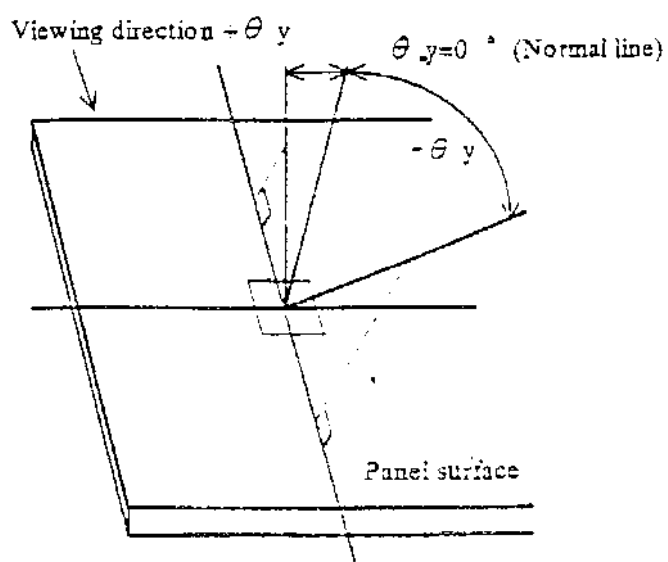

Fig.1 Definition of viewing angle

2) This module should be installed using mounting holes of metal bezel.

When installing the module, pay attention and handle carefully not to allow any undue stress such as twist or bend.

3) Since the front polarizer is easily damaged. Please pay attention not to scratch on its face.

It is recommended to use a transparent acrylic resin board or other type of protective panel on the surface of the LCD module to protect the polarizer, LCD panel, etc..

4) If the surface of the LCD panel is required to be cleaned, wipe it swiftly with cotton or other soft cloth. If it is not still clear completely, blow on and wipe it.

5) Water droplets, etc. must be wiped off immediately since they may cause color changes, staining, etc.. if it remained for a long time.

6) Since LCD is made of glass substrate, dropping the module or banging it against hard objects may cause cracking or fragmentation.

5/33

HARP

SPEC No. LC98702	MODEL No. LM12S471F	PAGE 2
---------------------	------------------------	-----------

Since CMOS LSIs are equipped in this module, following countermeasures must be taken to avoid electrostatics charge.

1. Operator

Electrostatic shielding clothes shall be had because it is feared that the static electricity is electrified to human body in case that operator have a insulating garment.

2. Equipment

There is a possibility that the static electricity is charged to equipment which have a function of peeling or mechanism of friction(EX: Conveyer, soldering iron, working table), so the countermeasure(electrostatic earth: $1 \times 10^8 \Omega$) should be made.

3. Floor

Floor is a important part to leak static electricity which is generated from human body or equipment. There is a possibility that the static electricity is charged to them without leakage in case of insulating floor, so the countermeasure(electrostatic earth: $1 \times 10^8 \Omega$) should be made.

4. Humidity

Humidity of working room may lower electrostatics generating material's resistance and have something to prevent electrifying. So, humidity should be kept over 50% because humidity less than 50 % may increase material's electrostatic earth resistance and it become easy to electrify.

5. Transportation/storage

The measure should be made for storage materials because there is a possibility that the static electricity, which electrify to human body or storage materials like container by friction or peeling, cause the dielectric charge.

6. Others

he laminator is attached on the surface of LCD module to prevent from scratches, fouling and dust. It should be peeled off unhurriedly with using static eliminator.

And also, static eliminator should be installed to prevent LCD module from electrifying at assembling line.

- 8) Don't use any materials which emit gas from epoxy resin(amines' hardener) and silicon adhesive agent(dealcohol or deoxym) to prevent change polarizer color owing to gas.
- 9) Since leakage current, which may be caused by routing of CCFT cables, etc., may affect the brightness of display, the inverter has to be designed taking the leakage current into consideration. Thorough evaluation of the LCD module/inverter built into its host equipment shall be conducted, therefore, to ensure the specified brightness.
- 10) Avoid to expose the module to the direct sun-light, strong ultraviolet light, etc. for a long time.
- 11) If stored at temperatures under specified storage temperature, the LC may freeze and be deteriorated. If storage temperature exceed the specified rating, the molecular orientation of the LC may change to that of a liquid, and they may not revert to their original state. Therefore, the module should be always stored at normal room temperature.
- 12) Disassembling the LCD module can cause permanent damage and should be strictly avoided.

SHARP

SPEC No. LC98702	MODEL No. LM12S471F	PAGE 3
---------------------	------------------------	-----------

13) Procedure insert mating connector

When the mating connector is inserted, it should be parallel to the used connector of LCD module and it should be inserted on horizontal firm base.

When the mating connector is attempted to be fixed to LCD connector, it should be inserted properly in order not to create a gap as shown "A".

Please insert the connector as both edge is placed to the connect position of LCD connector.

1) Method of correct insert

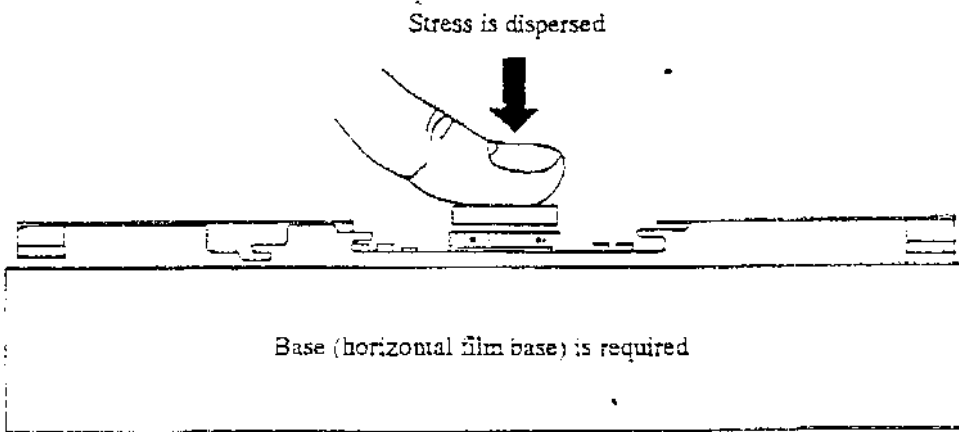

2) Method of wrong insert

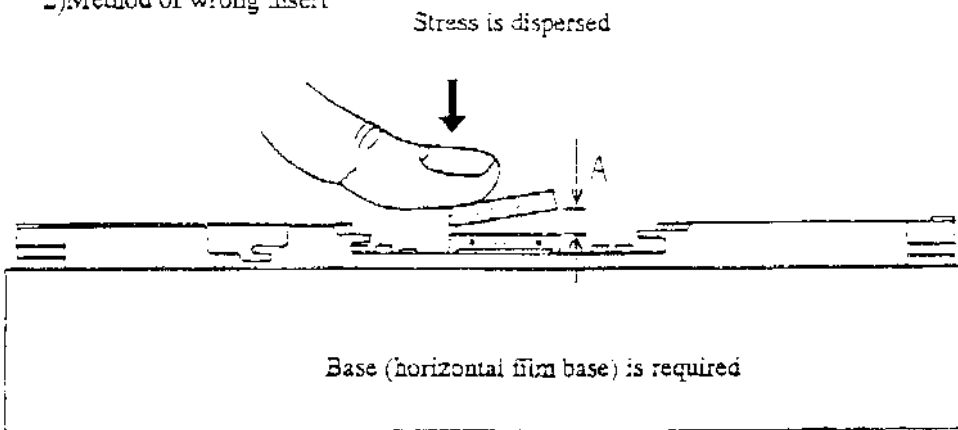

HARP

SPEC No.	MODEL No.	PAGE
LC98702	LM12S471F	4

- 13) This specification describes display quality in case of no gray scale. Since display quality can be affected by gray scale methods, display quality shall be carefully evaluated for the usability of LCD module in case gray scale is displayed on the LCD module.
- 15) The module should be driven according to the specified ratings to avoid permanent damage.
DC voltage drive leads to rapid deterioration of LC, so ensure that the drive is alternating waveform by continuous application of the signal M. Especially the power ON/OFF sequence shown on Page 29 should be kept to avoid latch-up of drive LSI and application of DC voltage to LCD panel
- 16) It is a characteristic of LCD to maintain the displaying pattern when the pattern is applied for a long time. (Image retention)
To prevent image retention, please do not apply the fixed pattern for along time by pre-installing such programs at your side.
- 17) This phenomena (image retention) is not deterioration of LCD. If it happens, you can remove it by applying different patterns.
- 18) CCFT backlight should be kept OFF during VDD is "L" level.

WARNING

Don't use any materials which emit following gas from epoxy resin (amines hardener) and silicone adhesive agent (deanol or deoxym) to prevent change polarizer color owing to gas.

8/33

HARP

SPEC No. LC98702	MODEL No. LM12S471F	PAGE 5
---------------------	------------------------	-----------

Contents	Page
1.Application	6
2.Construction and Outline	
3.Mechanical Specifications	7
4.Absolute Maximum Ratings	
4-1.Electrical absolute maximum ratings	
4-2.Environment Conditions	8
5.Electrical Specifications	9
5-1. Electrical characteristics	
5-2.Interface signals	12
6.Module Driving Method	18
6-1.Circuit configuration	
6-2.Display face configuration	
6-3.Input data and control signal	
7.Optical Characteristics	20
8.Characteristics of Backlight	25
9.Supply voltage sequence condition	27
10.Applicable Inspection Standard	28

9/33

HARP

SPEC No. LC98702	MODEL No. LM12S471F	PAGE 6
---------------------	------------------------	-----------

Application

This data sheet is to introduce the specification of LM12S471F, passive Matrix type Color LCD module.

Construction and Outline

Construction: 800 × 600 dots color display module consisting of an LCD panel, PWB(printed wiring board) with electric components mounted onto, TCP(tape carrier package) to connect the LCD panel and PWB electrically, and plastic chassis with CCFT back light and bezel to fix them mechanically.

Signal ground(Vss) is connected with the metal bezel.

DC/DC converter is built in.

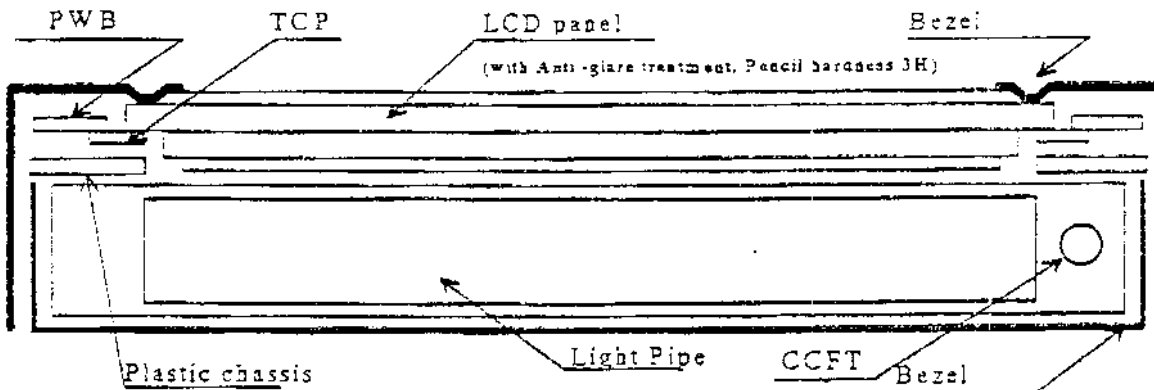

- Outline :See Fig. 13
- Connection :See Fig. 13 and Table 6

10/33

HARP

SPEC No. LC98702	MODEL No. LM12S471F	PAGE 7
---------------------	------------------------	-----------

Mechanical Specification

Table1

Parameter	Specifications	Unit
Outline dimensions	275 ± 0.5(W) × 202.5 ± 0.5(H) × 8.3MAX(D)	mm
Active area	245.98(W) × 184.48(H)	mm
Display format	800(W) × 600(H)	mm
Dot size	0.0825 × RGB(W) × 0.2875(H)	-
Dot spacing	0.02	mm
*1 Base color	Normally black *2	-
Weight	Aporox. 500	g

- *1 Due to the characteristics of the LC material, the colors vary with environmental temperature.
- *2 Negative-type display
 - Display data "H": ON → transmission
 - Display data "L": OFF → light isolation

Absolute Maximum Ratings

-1. Electrical absolute maximum ratings

Table 2

Parameter	Symbol	MIN.	MAX.	Unit	Remark
Supply voltage (Logic)	V _{DD} -V _{SS}	0	6.0	V	Ta=25 °C
Input voltage	V _{IN}	-0.3	V _{DD} +0.3	V	Ta=25 °C
Vcon voltage	Vcon	0	V _{DD}	V	Ta=25 °C

11/33

HARP

SPEC No. LC98702	MODEL No. LM12S471F	PAGE 8
---------------------	------------------------	-----------

Environment Conditions

Table 3

Item	Tstg		Topr		Remark
	MIN.	MAX.	MIN.	MAX.	
Ambient temperature	-25 °C	+60 °C	0 °C	+40°C	Note 4)
Humidity	Note 1)		Note 1)		No condensation
Vibration	Note 2)		Note 2)		3 directions(X/Y/Z)
Shock	Note 3)		Note 3)		6 directions(=X= Y= Z)

Note 1) Ta ≤ 40 °C.....95 % RH Max.
 Ta > 40 °C.....Absolute humidity shall be less than Ta=40 °C/95 % RH.

Note 2)

Table 4

Vibration Level	34.3 m/s ²
Waveform	Random
Bandwidth	10 to 500 Hz
Duration	One hour each axis

Note 3) Shock Level : 2156 m/s²
 Waveform : 1/2 Sinewave,2 ms
 No. of shocks : 6 Total(One time each face)

Note 4) Care should be taken so that the LCD module may not be subjected to the temperature out of this specification.

12/33

IARP

SPEC No. LC98702	MODEL No. LM12S471F	PAGE 9
---------------------	------------------------	-----------

Electrical Specifications
Electrical characteristics

Table 5-1 Ta=25 °C VDD= 3.3 V±10% 1/tFRM=150 Hz (Note 4)

Parameter	Symbol	Conditions	Min.	Typ.	Max.	Unit	
Supply voltage (Logic)	V _{DD} -V _{SS}	Ta = 0~40 °C (Note 1)	3.0	3.3	3.6	V	
Contrast adjust voltage (Note 4)	V _{con} -V _{SS}	Ta = 0 °C	1.0			V	
		Ta = 25 °C	1.7	1.9	2.1	V	
		Ta = 40 °C			2.5	V	
Input signal voltage	V _{IN}	"H" level	Ta = 0~40 °C	0.7V _{DD}	-	V _{DD}	V
		"L" level		0	-	0.3V _{DD}	V
Supply current	I _{DD1} (TYP.)	Ta = 25 °C (Note 1.2)	-	170	240	mA	
	I _{DD2} (MAX.)	Ta = 25 °C (Note 1.3)	-	340	480	mA	
Rush current (Logic)	I _{rush}	Ta = 25 °C (Note 1)	2 A(pk) × 50 ms				
Ripple current (Logic)	I _{rip}	Ta = 25 °C (Note 1)	1 A(pk) × 100 μs				
Power consumption	Pd1(TYP)	Note 2)	-	570	800	mW	
	Pd2(MAX)	Note 3)	-	1130	1590	mW	

Note 1) Under the following conditions:

- ① Immediately after the rise of V_{DD} : 2 A(pk) × 50 ms
- ② Under the situation that DISP signal is on and kept steady : 1 A(pk) × 100 μs

Note 2) Frame Frequency = 150 Hz, V_{con} - V_{SS} = 1.9 V

Display pattern = all digits ON (DU0-7, DL0-7 = "H")



Note 3) Frame Frequency = 150 Hz, V_{con} - V_{SS} = 1.9 V

Display pattern = black/white stripe pattern

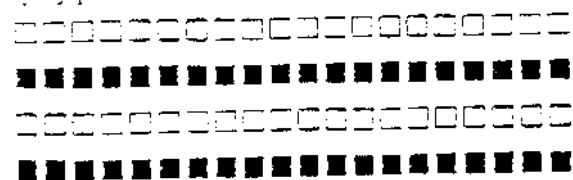

Note 4) The shadowing is adjusted on this module to the following conditions. When LCD module is operated in the other conditions, that should be informed in advance because display quality may be deteriorated in this case.

Frame frequency : 150 Hz

13/33

HARP

SPEC No. LC98702	MODEL No. LM12S471F	PAGE 10
----------------------------	-------------------------------	-------------------

Table 5-2 Ta=25 °C VDD= 5.0 V=10 % 1/FRM=150 Hz (Note 4)

Parameter	Symbol	Conditions	Min.	Typ.	Max.	Unit	
Supply voltage (Logic)	$V_{DD}-V_{SS}$	Ta = 0~40 °C (Note 1)	4.5	5.0	5.5	V	
Contrast adjust voltage (Note 5)	$V_{CON}-V_{SS}$	Ta = 0 °C	1.0			V	
		Ta = 25 °C	1.7	1.9	2.1	V	
		Ta = 40 °C			2.5	V	
Input signal voltage	V_{IN}	"H" level	Ta = 0~40 °C	0.7V _{DD}	-	V _{DD}	V
		"L" level		0	-	0.3V _{DD}	V
Supply current	I _{DD1} (TYP.)	Ta = 25 °C(Note 1,2)	-	180	250	mA	
	I _{DD2} (MAX.)	Ta = 25 °C(Note 1,3)	-	270	390	mA	
Rush current (Logic)	I _{rush}	Ta = 25 °C (Note 1)	2 A(pk) × 50 ms				
Ripple current (Logic)	I _{rip}	Ta = 25 °C (Note 1)	1 A(pk) × 100 μs				
Power consumption	Pd1(TYP)	Note 2)	-	900	1 250	mW	
	Pd2(MAX)	Note 3)	-	1 350	1 950	mW	

Note 1) Under the following conditions.:

- ① Immediately after the rise of V_{DD}. : 2 A(pk) × 50 ms
- ② Under the situation that DISP signal is on and kept steady : 1 A(pk) × 100 μs

Note 2) Frame Frequency = 150 Hz , V_{con} - V_{ss} = 1.9 V

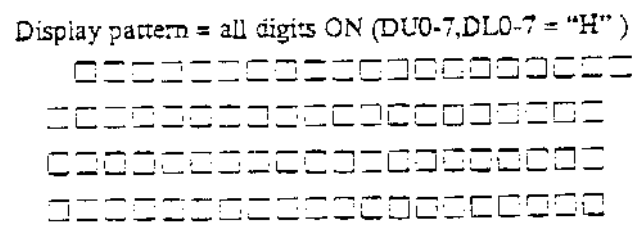

Note 3) Frame Frequency = 150 Hz , V_{con} - V_{ss} = 1.9 V

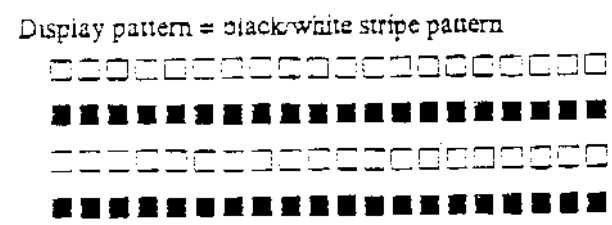

Note 4) The shadowing is adjusted on this module to the following conditions. When LCD module is operated in the other conditions, that should be informed in advance because display quality may be deteriorated in this case.

Frame frequency : 150 Hz

14/35

SHARP

SPEC No. LC98702	MODEL No. LM12S471F	PAGE 11
---------------------	------------------------	------------

Note 5) Contrast adjust voltage "Vcon-Vss" is transformed into the LCD driving voltage "V_{LCD}" by following circuit built in the LCD module.

LCD driving voltage "V_{LCD}" is adjusted automatically according to the change of ambient temperature range by the temperature compensation circuit.

Temperature compensation circuit built in LCD module have been set obtain the optimum contrast under following driving conditions.;

Take care that voltage for optimum contrast is changed under the different condition.

Frame frequency : 150 Hz, Duty ratio : 1/300 (an odd number frame), Ta = 25 °C
1/328 (an even number frame)

※The above is the condition of the module setting, not the electrical characteristics.

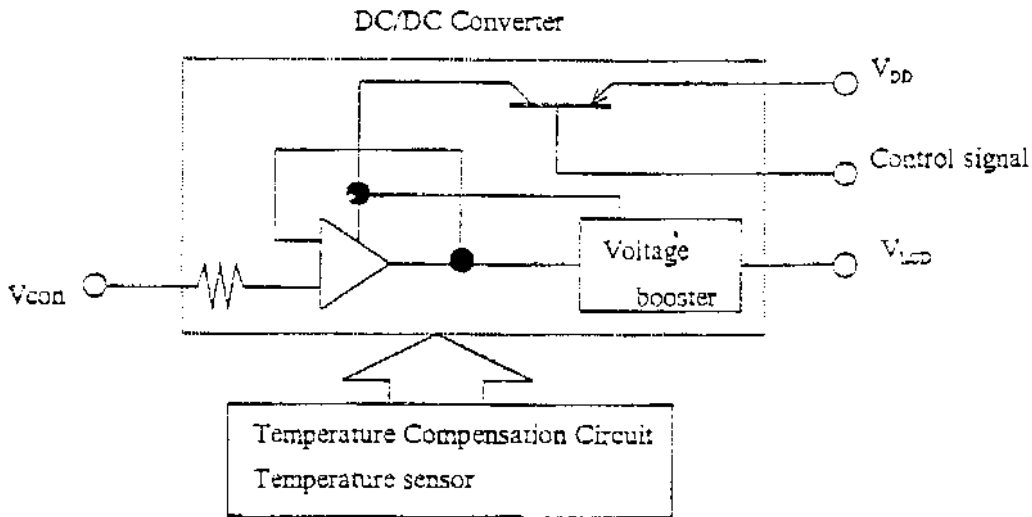

15/33

HARP

SPEC No. LC98702	MODEL No. LM12S471F	PAGE 12
---------------------	------------------------	------------

2. Interface signals

OLCD

Table 5

Pin No.	Symbol	Description	Level
1	VSS	Ground potential	-
2	XCK	Data input clock signal	"H" - "L"
3	VSS	Ground potential	-
4	VSS	Ground potential	-
5	LP	Input data latch signal	"H" - "L"
6	YD	Scan start-up signal	"H"
7	VSS	Ground potential	-
8	VSS	Ground potential	-
9	VDD	Power supply for logic and LCD	-
10	DISP	Display control signal	H(ON), L(OFF)
11	VSS	Ground potential	-
12	VSS	Ground potential	-
13	VSS	Ground potential	-
14	DL7	Display data signal (Lower)	H(ON), L(OFF)
15	DL6	Display data signal (Lower)	H(ON), L(OFF)
16	DL5	Display data signal (Lower)	H(ON), L(OFF)
17	DL4	Display data signal (Lower)	H(ON), L(OFF)
18	DL3	Display data signal (Lower)	H(ON), L(OFF)
19	DL2	Display data signal (Lower)	H(ON), L(OFF)
20	DL1	Display data signal (Lower)	H(ON), L(OFF)
21	DL0	Display data signal (Lower)	H(ON), L(OFF)
22	VSS	Ground potential	-
23	VSS	Ground potential	-
24	VSS	Ground potential	-
25	DU0	Display data signal (Upper)	H(ON), L(OFF)
26	DU1	Display data signal (Upper)	H(ON), L(OFF)
27	DU2	Display data signal (Upper)	H(ON), L(OFF)
28	DU3	Display data signal (Upper)	H(ON), L(OFF)
29	DU4	Display data signal (Upper)	H(ON), L(OFF)
30	DU5	Display data signal (Upper)	H(ON), L(OFF)
31	DU6	Display data signal (Upper)	H(ON), L(OFF)
32	DU7	Display data signal (Upper)	H(ON), L(OFF)
33	VSS	Ground potential	-
34	VSS	Ground potential	-
35	VSS	Ground potential	-
36	VDD	Power supply for logic and LCD	-
37	VDD	Power supply for logic and LCD	-
38	Vcon	Contrast adjust voltage	-
39	NC	NC	-
40	VSS	Ground potential	-
41	VSS	Ground potential	-

16/53



SPEC No. LC98702	MODEL No. LM12S471F	PAGE 13
---------------------	------------------------	------------

○CCFT

Pin No	Symbol	Description	Level
1	HV	High voltage line (from Inverter)	-
2	NC	NC	-
3	GND	Ground line (from Inverter)	-

○LCD

Used connector : DF9B-41P-1V(HIROSE)
 Correspondable connector : DF9B-41S-1V(HIROSE)

○CCFT

Used connector : BHR-03VS-1 (JST)
 Correspondable connector : SM02(8.0)B-BHS(JST)

Except above connector shall be out of guaranty.

18/33

SHARP

SPEC No. LC98702	MODEL No. LM12S471F	PAGE 15
---------------------	------------------------	------------

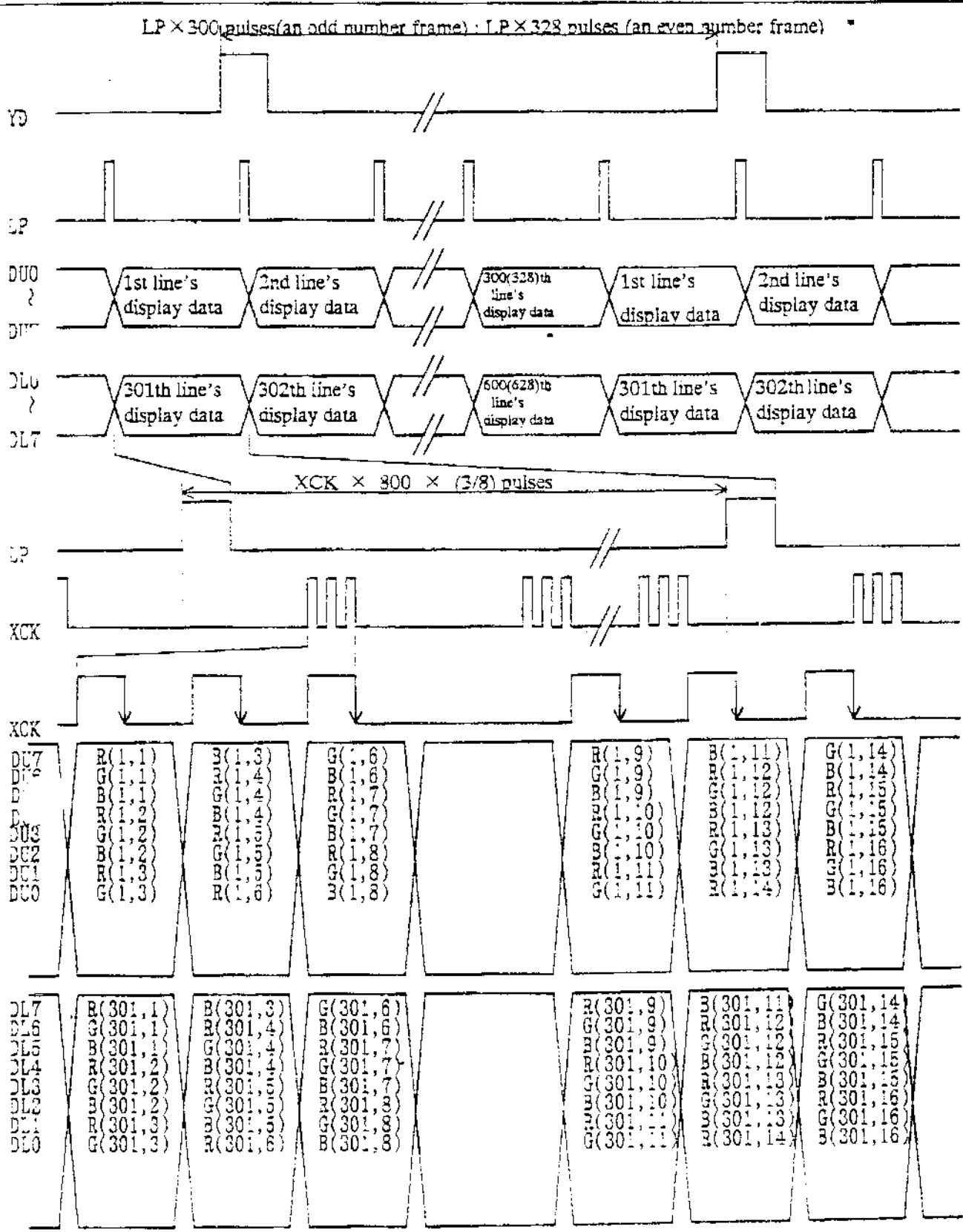

*Electrical and optical characteristics are specified by above condition.

Fig. 3 Data input timing chart

HARP

SPEC No. LC98702	MODEL No. LM12S471F	PAGE 17
---------------------	------------------------	------------

Table 7 Interface timing ratings

Ta=25 °C, VDD=3.0 ~ 5.5 V

Item	Symbol	Rating			Unit
		MIN.	TYP.	MAX.	
Frame cycle *2	t _{FRM}	6.66		16.94	ms
XCK signal clock cycle	t _{CK}	50			ns
"H" level clock width	t _{wCKH}	16			ns
"L" level clock width	t _{wCKL}	15			ns
LP signal "H" level pulse width	t _{wLPH}	200			ns
Data set up time	t _{DS}	~ 14			ns
hold time	t _{DH}	20			ns
YD signal "H" level set up time	t _{YDS}	100			ns
"H" level hold time	t _{YDH}	100			ns
"L" level set up time	t _{YDS}	100			ns
"L" level hold time	t _{YDL}	40			ns
LP ~ allowance time from XCK ↓	t _{LS}	200			ns
XCK ~ allowance time from LP ↓	t _{CS}	200			ns
Input signal rise/fall time *1	t _{RI}			13	ns

- *1 When LCD module is operated by high speed of XCK(Shift clock), (t_{CK} - t_{wCKH} - t_{wCKL})/2 is maximum.
- *2 As for the specification of frame cycle, it is required to keep the conditions of the other Interface timing ratings.

The shadowing is adjusted on this module to the following conditions. When LCD module is operated in the other conditions, that should be informed in advance because display quality may be deteriorated in this case.

Frame frequency : 150 Hz(Frame cycle : 6.66 ms)

Owing to the characteristics of LCD module, "shadowing" will become more eminent as frame frequency goes up, while flicker will be reduced.

since judgment of display quality is subjective and display quality such as "shadowing" is pattern dependent, it is recommended that decision of frame frequency, to which power consumption of the LCD module is proportional, be made based on your own through testing on the LCD module with every possible patterns displayed on it

- ※ The intervals of one LP fall and next must be always the same, and LPs must be input continuously.
The intervals must be 70 μs Max.

21/33

SHARP

SPEC No. LC98702	MODEL No. LM12S471F	PAGE 18
---------------------	------------------------	------------

5. Module Driving Method

6-1. Circuit configuration

Fig.10 shows the block diagram of the module's circuitry.

6-2. Display face configuration

The display consists of $800 \times 3(R,G,B) \times 600$ dots as shown in Fig. 2.

The interface is single panel with double drive to be driven at 1/300(1/328) duty ratio.

(1/300:an odd number frame. 1/328:an even number frame)

6 Input data and control signal

The LCD driver is 240 bits LSI, consisting of shift registers, latch circuits and LCD driver circuits. Input data for each row ($800 \times 3 R,G,B$) will be sequentially transferred in the form of 8 bit parallel data through shift registers from top left of the display together with clock signal (XCK).

When input of one row ($800 \times 3 R,G,B$) is completed, the data will be latched in the form of parallel data corresponding to the signal electrodes by the falling edge of latch signal (LP) then, the corresponding drive signals will be transmitted to the 800×3 lines of column electrodes of the LCD panel by the LCD drive circuits.

At this time, scan start-up signal (YD) has been transferred from the scan signal driver to the 1st row of scan electrodes, and the contents of the data signals are displayed on the 1st row of the display face according to the combinations of voltages applied to the scan and signal electrodes of the LCD. While the data of 1st row are being displayed, the data of 2nd row are entered. When data for 800×3 dots have been transferred, they will be latched by the falling edge of LP, switching the display to the 2nd row.

Such data input will be repeated up to the 300(328)th row of each display segment, from upper row to lower rows, to complete one frame of display by time sharing method.

Simultaneously the same scanning sequence occur at the lower panel.

Then data input proceeds to the next display frame.

YD generates scan signal to drive horizontal electrodes.

Since DC voltage, if applied to LCD panel, causes chemical reaction in LC materials, causing deterioration of the materials, drive wave-form shall be inverted at every display frame to prevent the generation of such DC voltage. Control signal M plays such a role.

22/33



SPEC No. LC98702	MODEL No. LM12S471F	PAGE 19
---------------------	------------------------	------------

Because of the characteristics of the CMOS driver LSI, the power consumption of the display module goes up with the clock frequency of XCK.

To minimize data transfer speed of XCK clock the LSI has the system of transferring 8 bit parallel data through the 8 lines of shift registers.

Thanks to this system the power consumption of the display module is minimized.

In this circuit configuration, 8 bit display data shall input to data input pins of DU0-7 and DL0-7.

Furthermore, the display module has bus line system for data input to minimize the power consumption with data input terminals of each driver LSI being activated only when relevant data input is fed.

Data input for column electrodes and chip select of driver LSI are made as follows:

The driver LSI at the left end of the display face is first selected, and the adjacent driver LSI right next side is selected when data of 240 dot (30XCK) is fed. This process is sequentially continued until data is fed to the driver LSI at the right end of the display face. This process is followed simultaneously both at the top and bottom column drivers LSI's.

Thus data input will be made through 8 bit bus line sequentially from the left end of the display face.

Since this display module contains no refresh RAM, it requires the above data and timing pulse inputs even for static display.

The timing chart of input signals are shown in fig. 4 and Table 3.

23/33

SHARP

SPEC No. LC98702	MODEL No. LM12S471F	PAGE 20
---------------------	------------------------	------------

Optical Characteristics

Following spec are based upon the electrical measuring conditions, on which the contrast of perpendicular direction ($\theta_x = \theta_y = 0^\circ$) will be MAX.

Table 8 $T_a = 25^\circ\text{C}$, $V_{DD} = 3.3\text{V}$, $V_{CON} - V_{SS} = V_{MAX}$

Parameter	Symbol	Condition	MIN.	TYP.	MAX.	Unit	Remark	
Viewing angle range	θ_x	$C_o > 5.0$	$\theta_y = 0^\circ$	-30	-	30	Note 1)	
	θ_y		$\theta_x = 0^\circ$	-15	-	25		
Contrast ratio	C_o	$\theta_x = \theta_y = 0^\circ$	-	40	-	-	Note 2)	
Response	Rise	τ_r	$\theta_x = \theta_y = 0^\circ$	-	120	180	ms	Note 3)
	Decay	τ_d	$\theta_x = \theta_y = 0^\circ$	-	30	50	ms	
Module Chromaticity	White	x	$\theta_x = \theta_y = 0^\circ$	-	0.280	-	-	
		y	$\theta_x = \theta_y = 0^\circ$	-	0.330	-	-	

Note 1) The viewing angle range is defined as shown Fig.5.

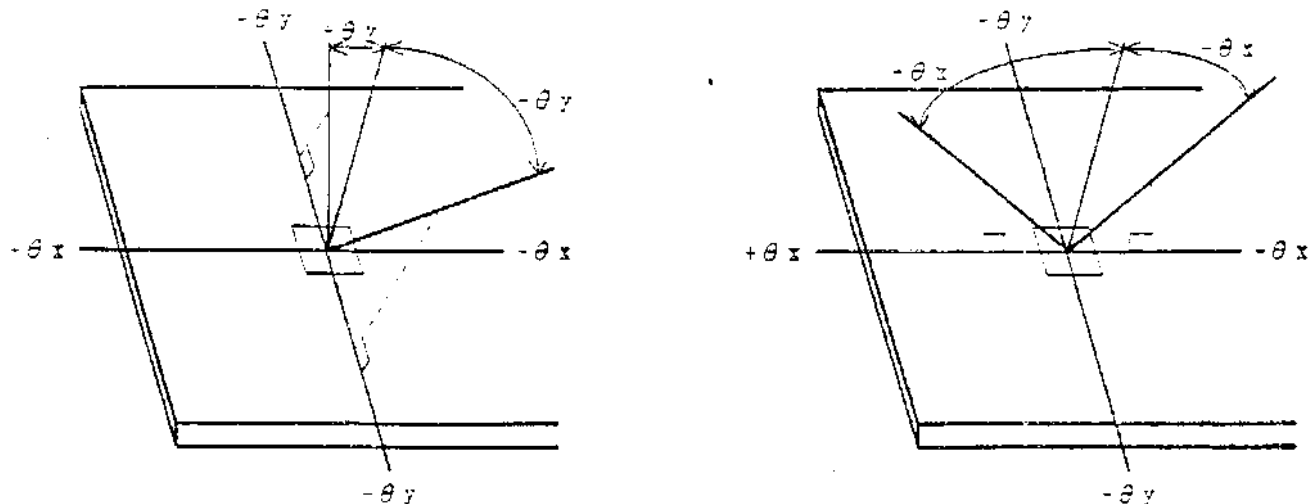

Fig.5 Definition of Viewing Angle

Note 2) Contrast ratio is defined as follows:

$$C_o = \frac{\text{Luminance(brightness) all pixels "White" at } V_{MAX}}{\text{Luminance(brightness) all pixels "dark " at } V_{MAX}}$$

V_{MAX} is defined in Fig.7.

Note 3) The response characteristics of photo-detector output are measured as shown in Fig.8, assuming that input signals are applied so as to select and deselect the dot to be measured, in the optical characteristics test method shown in Fig.9.

24/33

SHARP

SPEC No. LC98702	MODEL No. LM12S471F	PAGE 21
---------------------	------------------------	------------

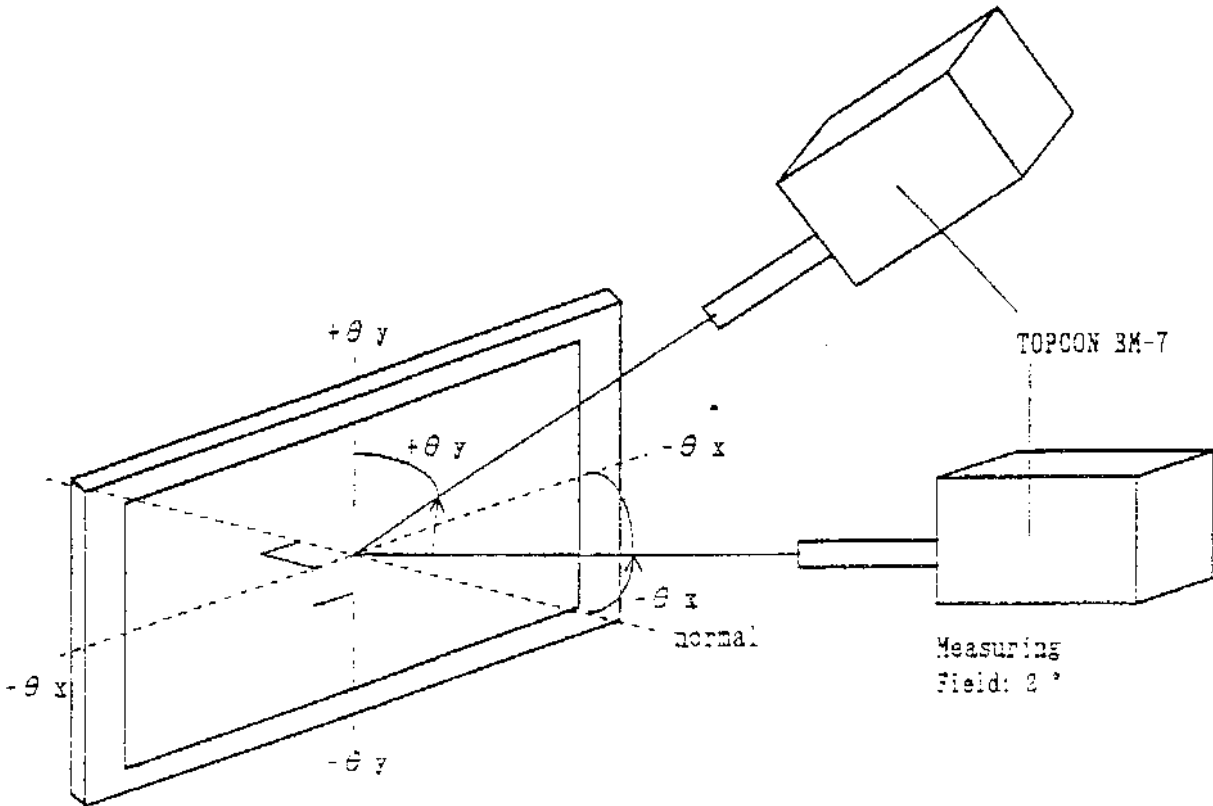

Measuring Spot Size : $\phi 10$ mm

θ_x : Angle from "normal" to viewing surface rotated about the horizontal axis.

θ_y : Angle from "normal" to viewing surface rotated about the vertical axis.

Fig.5 Optical Characteristics Test Method I

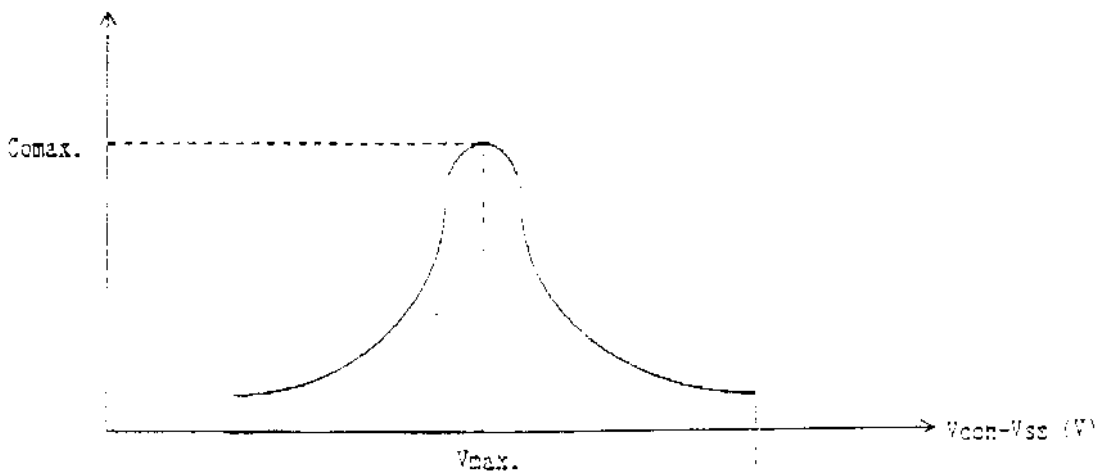

Fig.7 Definition of V_{max}

26/33

SHARP

SPEC No. LC98702	MODEL No. LM12S471F	PAGE 23
---------------------	------------------------	------------

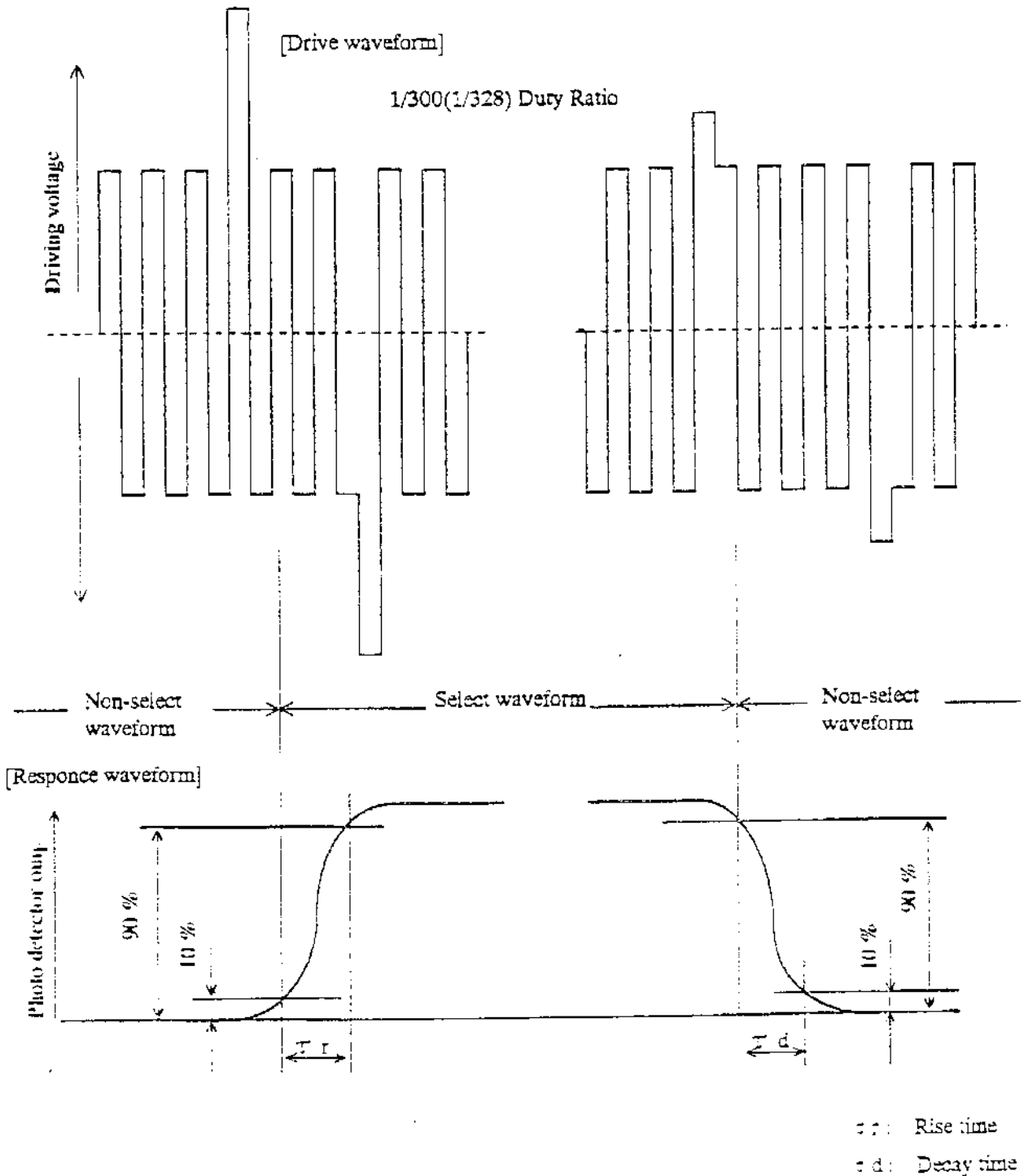

Fig.9 Definition of Response time

27/33

SHARP

SPSC No. LC98702	MODEL No. LM12S471F	PAGE 24
---------------------	------------------------	------------

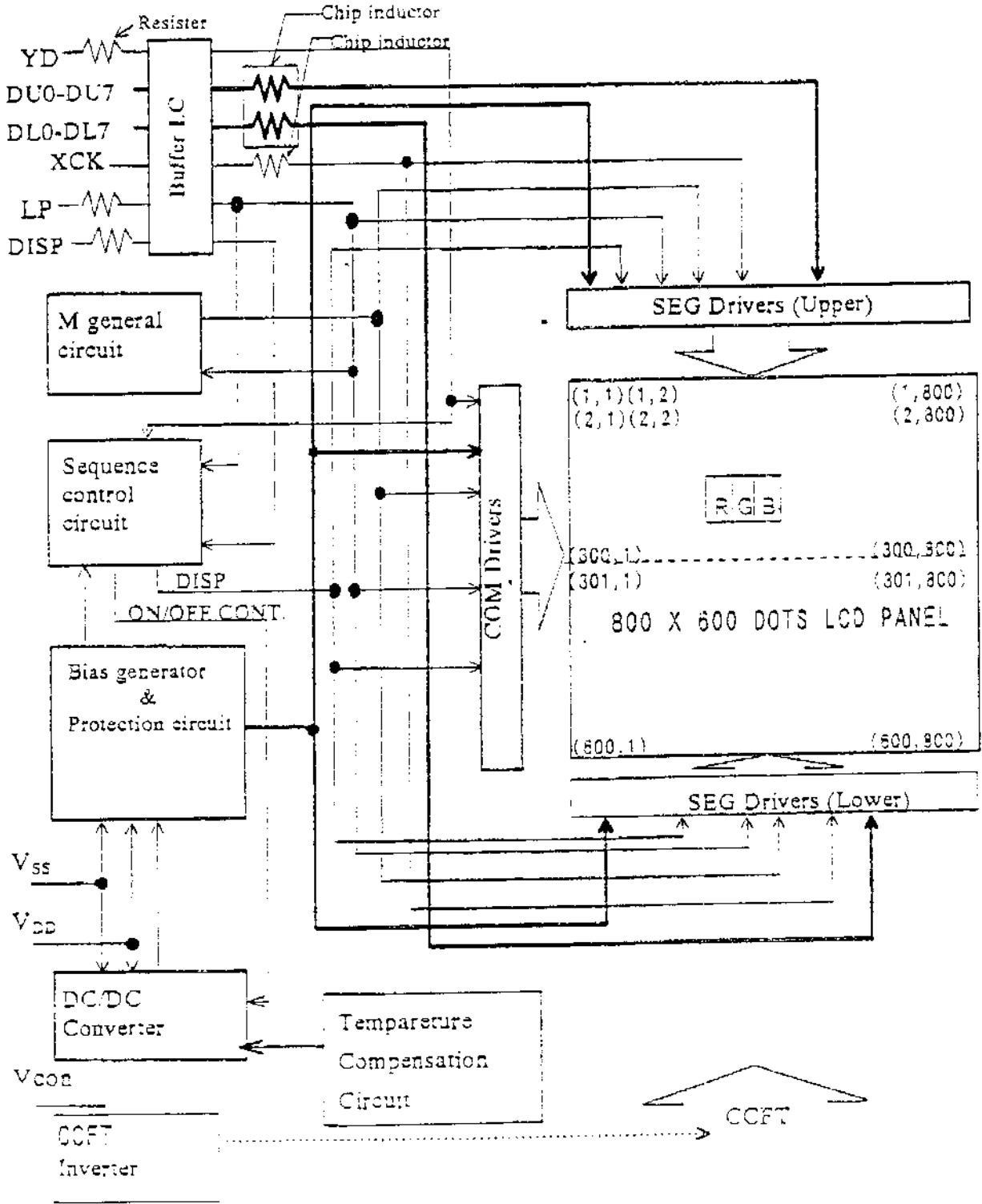

Fig. 10. Circuit block diagram

28/33

HARP

SPEC No. LC98702	MODEL No. LM12S471F	PAGE 25
---------------------	------------------------	------------

Characteristics of Backlight

The ratings are given on condition that the following conditions are satisfied.

1) Rating(Note)

Parameter	MIN.	TYP.	MAX.	Unit
Brightness	80	100	-	cd/m ²

2) Measurement circuit : CXA-L0612-VJL(TDK) (at IL = 5.0 mArms)

3) Measurement equipment : BM-7 (TOPCON Corporation)

4) Measurement conditions

Measurement circuit voltage : DC = (12.0) V, at primary side

4-2. LCD: All digits WHITE, VDD= 3.3 V, Vcon-VSS = Vmax, DU0-7="H"(White),DL0-7="H"(White)

Frame Frequency 150 Hz

4-3. Ambient temperature : 25 °C

Measurement shall be executed 30 minutes after turning on.

5) Used lamp : KON6260HS223121 (SANKEN ELECTRIC CO.LTD.)

Used cable : UL3579, AWG26

(NISSEI ELECTRIC CO.,LTD or SUMITOMO ELECTRIC INDUSTRIES LTD.)

5-1. Rating (1pc)

Parameter	Symbol	MIN.	TYP.	MAX.	Unit	Remark
Lamp voltage	V _L	-	600	-	Vrms	-
Lamp current	I _L	3.0	5.0	6.0	mArms	*1
Lamp power consumption	P _L	-	3.00	-	W	*2
Lamp frequency	F _L	50	-	80	kHz	-
Kick-off voltage	V _s	-	-	1 230	Vrms	Ta=25 °C
		-	-	1 400	Vrms	Ta= 0 °C
Lamp life time	L _L	15 000	25 000	-	h	-

Within no conductor closed. (CCFT only)

- *1 It is recommended that IL be not more than 5 mArms so that heat radiation of CCFT backlight may least affect the display quality.
- *2 Power consumption excluded inverter loss.
- *3 The circuit voltage(VS) of the inverter should be designed to have some margin, because VS may be increased due to the leak current in case of the LCD module.
- *4 Average life time of CCFT will be decreased when LCD is operating at lower temperature.

29/33

SHARP

SPEC No. LC98702	MODEL No. LM12S471F	PAGE 26
---------------------	------------------------	------------

5-2. Operating life

The operating life time is 15 000 hours or more at 5.0 mA , at 25°C. (Operating life with CXA-L0612-VJL or equivalent.)

The inverter should meet the following conditions to keep the specified life time of used lamp;

- Since, symmetric waveform without spike in positive and negative
- Output frequency range: 50 kHz-80 kHz

Make sure the operating conditions by executing the burn-in enough time.

The operating life time is defined as having ended when any of the following conditions occur; 25 ± 1 °C

- When the voltage required for initial discharge has reached 110 % of the initials value.
- When the illuminance quantity of light has decreased to 50 % of the initials value.

(NOTE) Rating are defined as the average brightness inside the viewing area specified in Fig.11.

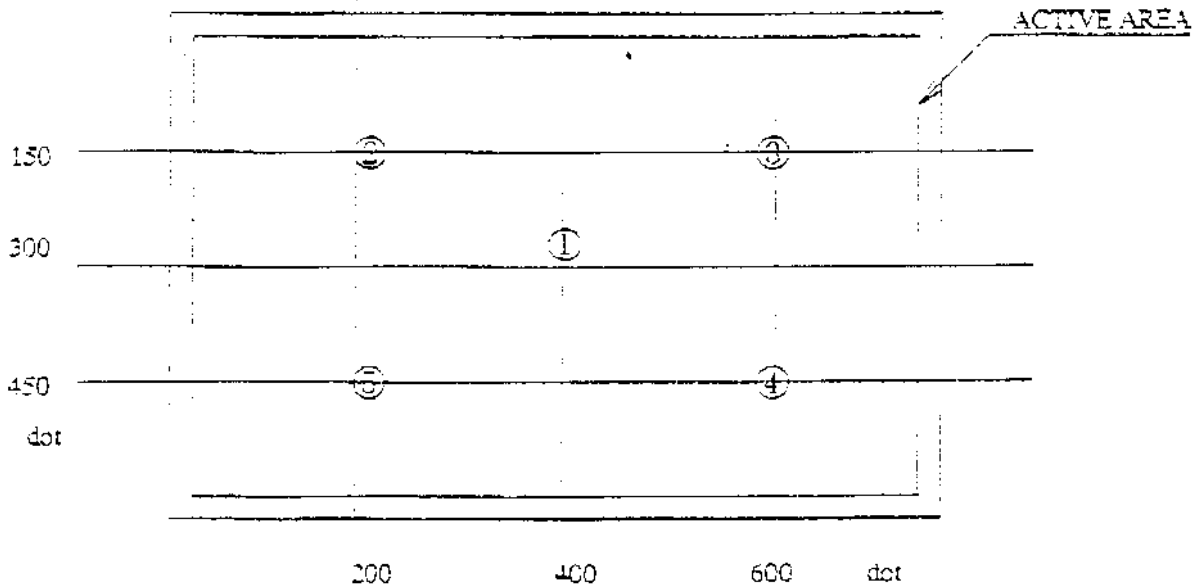

Fig.11 Measuring points (1-5)

30/33

SHARP

SPEC No. LC98702	MODEL No. LM12S471F	PAGE 27
---------------------	------------------------	------------

Supply voltage sequence condition

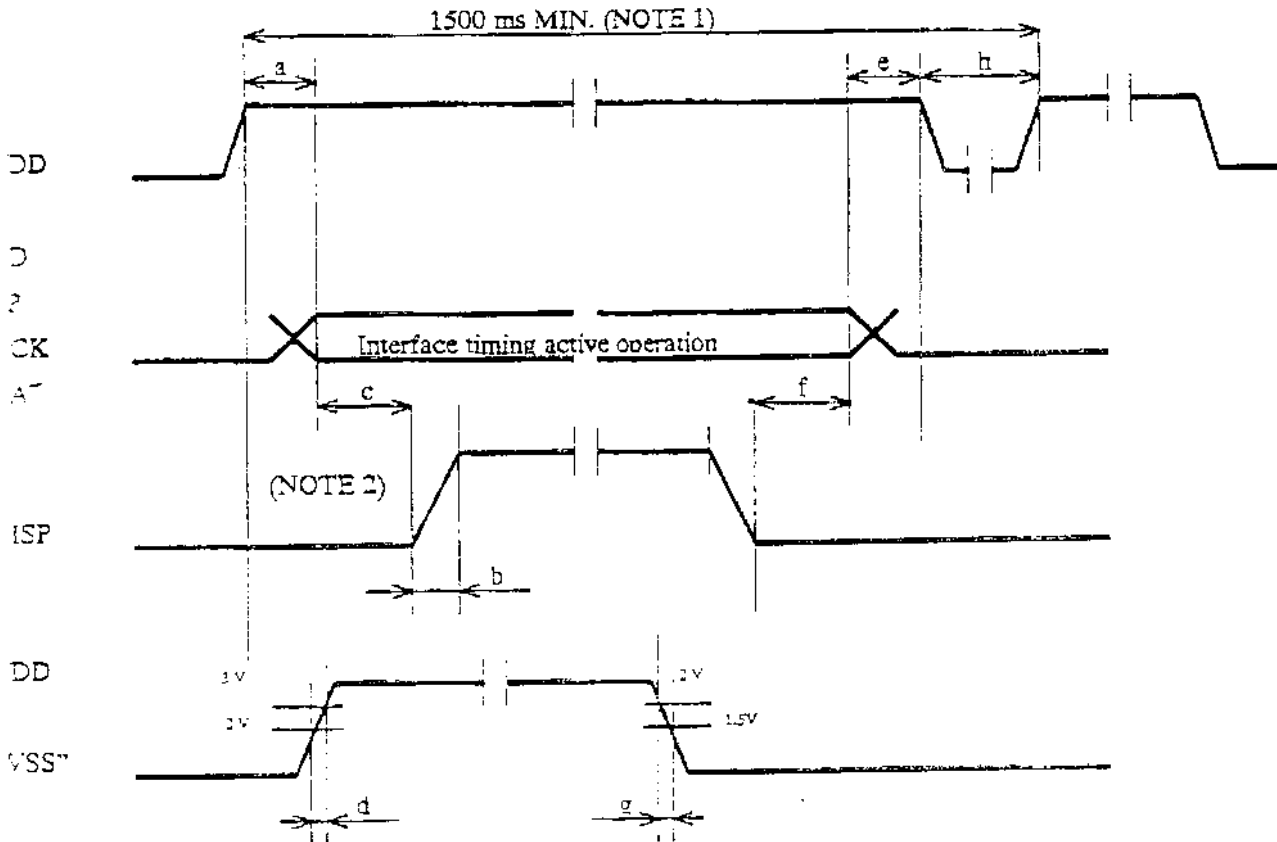

Fig.12 Supply voltage sequence condition

POWER ON		
Symbol	Allowable value	
a	0 ms MIN.	1 s MAX.
b	—	100 ns MAX.
c	50 ms MIN.	—
d	—	10 ms MAX.

POWER OFF		
Symbol	Allowable value	
e	0 ms MIN.	1 s MAX.
f	0 ms MIN.	—
g	10 ms MIN.	—
h	1 s MIN.	—

(NOTE 1) Power ON/OFF cycle time. All signals and power line shall be in accordance with above sequence in case of power ON/OFF.

(NOTE 2) Before DISP rise up, the signals of YD, LP, XCK, DATA must be input, and the above condition of "a" must be satisfied. The signals which comply with the interface timing in Fig.3, Fig.4, and table 6, must be input.

31/33

SHARP

SPEC No. LC98702	MODEL No. LM12S471F	PAGE 28
---------------------	------------------------	------------

10. Applicable inspection standard

The LCD module shall meet the following inspection standard: S-U-035-06

SPEC No. LC98702 MODEL No. LM12S471F

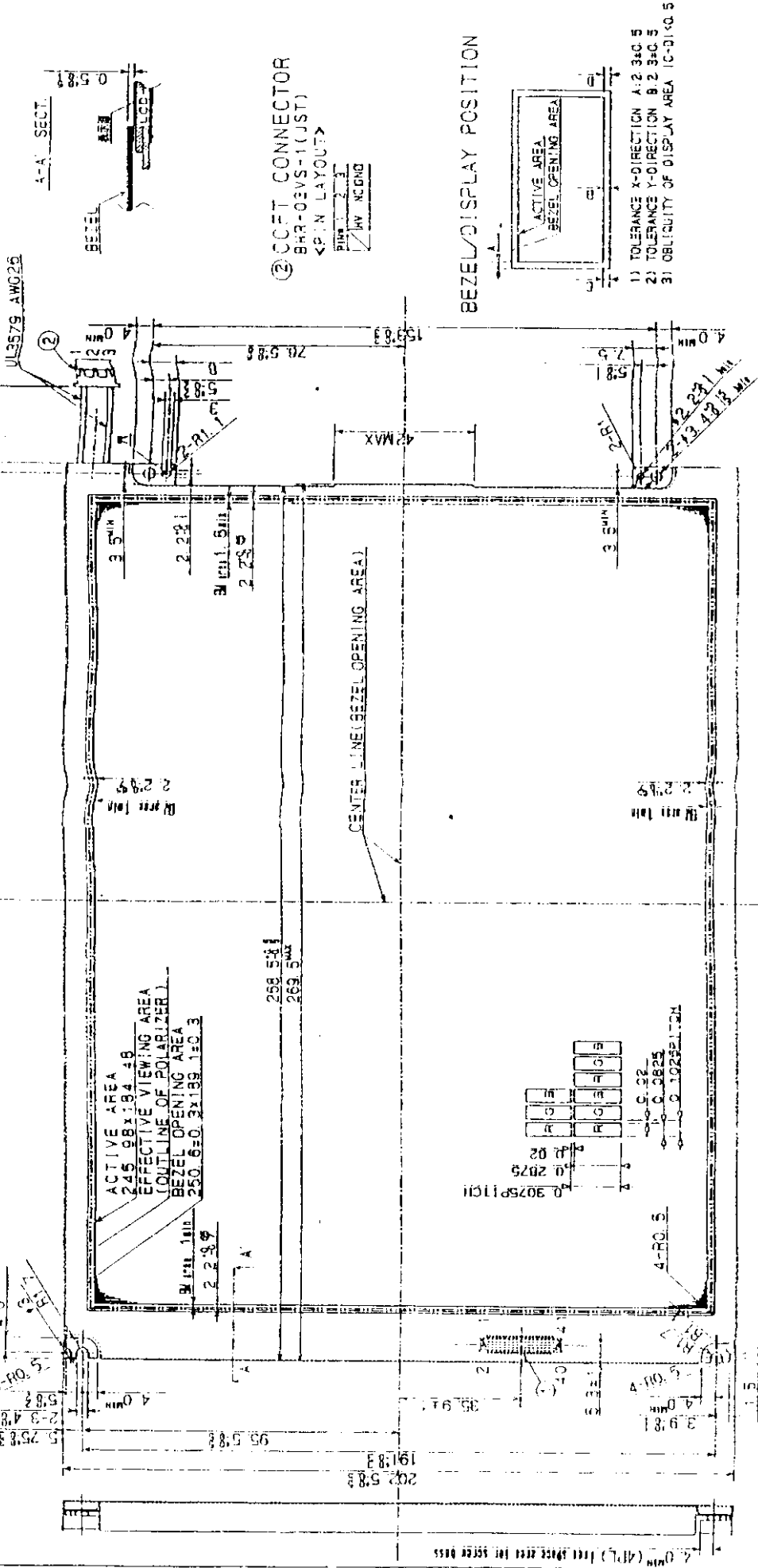

② CCFT CONNECTOR
BRR-03VS-1(JST)
← P.I.N. LAYOUT →
PIN 1 2 3
HV NC GND

BEZEL DISPLAY POSITION

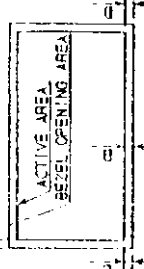

- 1) TOLERANCE X-DIRECTION ± 0.340 5
- 2) TOLERANCE Y-DIRECTION ± 0.340 5
- 3) OBLIQUITY OF DISPLAY AREA 10-D1<0.5

M12S471		LCD MODULE OUTLINE DIMENSIONS	
NO.	NAME	UNIT	VALUE
1	MODULE WIDTH	mm	131.5
2	MODULE HEIGHT	mm	270.5
3	MODULE WEIGHT	g	500 ± 30
4	MODULE PART NO.		LM12S471F
5	MODULE MANUFACTURER		SHARP CORPORATION
6	MODULE DATE		98.12.25

M12S471		INTERFACE CONNECTOR	
NO.	NAME	UNIT	VALUE
1	CONNECTOR TYPE		DF98-41P-1V(HIROSE)
2	CONNECTOR P.I.N. LAYOUT		← P.I.N. LAYOUT →
3	CONNECTOR PART NO.		DF98-41P-1V(HIROSE)
4	CONNECTOR MANUFACTURER		HIROSE ELECTRIC CO., LTD.
5	CONNECTOR DATE		98.12.25

THIS VALUE SHOWS THE THICKNESS AFTER MOUNTING.
P.P.C. ASKING TO CUSTOMER'S SECTION.