



LM1304/LM1305/LM1307/LM1307E FM multiplex stereo demodulator

general description

The LM1304, LM1305, LM1307 and LM1307E are designed to derive the left and right channel audio information from the detected composite stereo signal. The LM1304 eliminates the need for an external stereo-channel separation control. The LM1305 is similar to the LM1304 but permits the use of an external stereo-channel separation control for maximum separation. The LM1307 is also similar to the LM1304 but does not have the audio mute control, or the stereo/mono switch. The LM1307E is similar to the LM1307 but has the

option of emitter-follower output drivers for buffers or high current applications.

features

- Operation over a wide power supply range
- Built in stereo-indicator lamp driver — 100 mA typical
- Automatic switching between stereo and monaural
- Audio mute control

circuit schematics

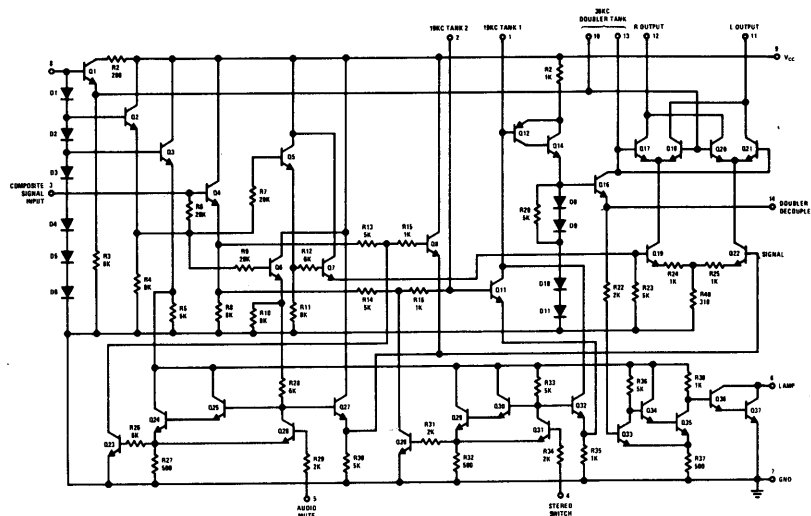

LM1304

Order Number LM1304N
or LM1305N or LM1307N
or LM1307EN
See Package 22

Order Number LM1304N-01
or LM1305N-01 or LM1307N-01
or LM1307EN-01
See Package 24

absolute maximum ratings

| | |
|--|---|
| Power Supply Voltage | +22V |
| Lamp Driver Current | 120 mA |
| Power Dissipation | 625 mW |
| Derate Above $T_A = +25^\circ\text{C}$ | 5.0 mW/ $^\circ\text{C}$ |
| Operating Temperature Range (Ambient) | 0°C to $+75^\circ\text{C}$ |
| Storage Temperature Range | -65°C to $+150^\circ\text{C}$ |
| Output Current (LM1307E) | 25 mA |
| Lead Temperature (Soldering, 10 sec) | 300°C |

electrical characteristics ($V_{CC} = 12\text{V}$, $T_A = 25^\circ\text{C}$, $75\ \mu\text{s}$ de-emphasis unless otherwise noted)

| PARAMETER | CONDITIONS | MIN | TYP | MAX | UNITS |
|---|-------------------------------------|-----|-----|-----|------------------|
| Input Impedance | $f = 1\ \text{kHz}$ | 12 | 20 | | $\text{k}\Omega$ |
| Stereo Channel Separation (Note 1) (Note 3) | $f = 100\ \text{Hz}$ | | 35 | | dB |
| | $f = 1\ \text{kHz}$ | 30 | 45 | | dB |
| | $f = 10\ \text{kHz}$ | | 30 | | dB |
| Channel Balance | Monaural Input = 200 mV | | 0.2 | 1.0 | dB |
| Total Harmonic Distortion (Note 1) | $f_{\text{MOD}} = 1\ \text{kc}$ | | 0.5 | 1.0 | % |
| Ultrasonic Frequency Rejection (Note 2) | 19 kHz | | 30 | | dB |
| | 38 kHz | 20 | 25 | | dB |
| Inherent SCA Rejection (Without De-Emphasis) | 60 kHz, 67 kHz, 74 kHz | | 50 | | dB |
| Lamp Indicator | $R_A = 180\Omega$ | | | | |
| | Min 19 kHz Input Level for Lamp On | | 16 | 25 | mVrms |
| | Max 19 kHz Input Level for Lamp Off | 5.0 | 14 | | mVrms |
| Power Dissipation | Without Lamp | | 150 | 300 | mW |
| Audio Muting (LM1304/5 Only) | Mute On (Pin 5 Voltage) | 0.6 | .8 | 1.0 | V |
| | Mute Off (Pin 5 Voltage) | 1.3 | 1.6 | 2.0 | V |
| | Attenuation in Mute Mode | | 55 | | dB |
| Stereo-Monaural Switching (LM1304/5 Only) | Stereo (Pin 4 Voltage) | 1.3 | 1.6 | 2.0 | V |
| | Monaural (Pin 5 Voltage) | 0.6 | .8 | 1.0 | V |

Note 1: Measurement made with standard multiplex composite signal. L = 1, R = 0 or L = 0, R = 1; composite signal defined as 564 mV peak to peak (100 mVrms as read on Ballantine 310-A voltmeter) with a 20 mVrms 19 kHz pilot carrier.

Note 2: Referenced to 1 kHz output signal with signal per Note 1.

Note 3: Stereo channel separation is adjusted for maximum separation in the LM1305 with a resistor from Pin 9 to GND.

($R_A = 180\Omega$, All voltages measured with respect to GND)

($V_{CC} = 12\text{V}$, 2.7 $\text{k}\Omega$ in series w/Pin 8)

| Pins | 1 | 2 | 3 | 4 | 5 | 6 | 7 | 8 | 9 | 10 | 11 | 12 | 13 | 14 |
|---------|----|-----|-----|-----|-----|-----|---|-----|------|-----|-----|-----|-----|-----|
| LM1304 | 12 | 2.3 | 3.0 | 1.9 | 1.9 | 0.8 | 0 | 4.6 | 12 | 3.9 | 9.7 | 9.7 | 3.9 | 1.9 |
| LM1305 | 12 | 2.3 | 3.0 | 1.9 | 1.9 | 0.8 | 0 | 12 | 0.36 | 3.9 | 9.7 | 9.7 | 3.9 | 1.9 |
| LM1307 | 12 | 2.3 | 3.0 | — | — | 0.8 | 0 | — | 12 | 3.9 | 9.7 | 9.7 | 3.9 | 1.9 |
| LM1307E | 12 | 2.3 | 3.0 | — | .8 | 12 | 0 | 9.7 | 9.0 | 9.0 | 9.7 | 3.9 | 3.9 | 1.9 |

circuit schematics (con't)

LM1304/LM1305/LM1307/LM1307E

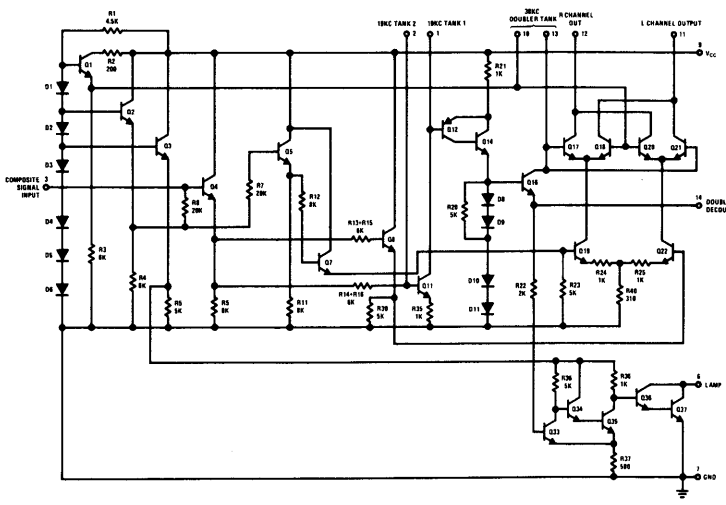
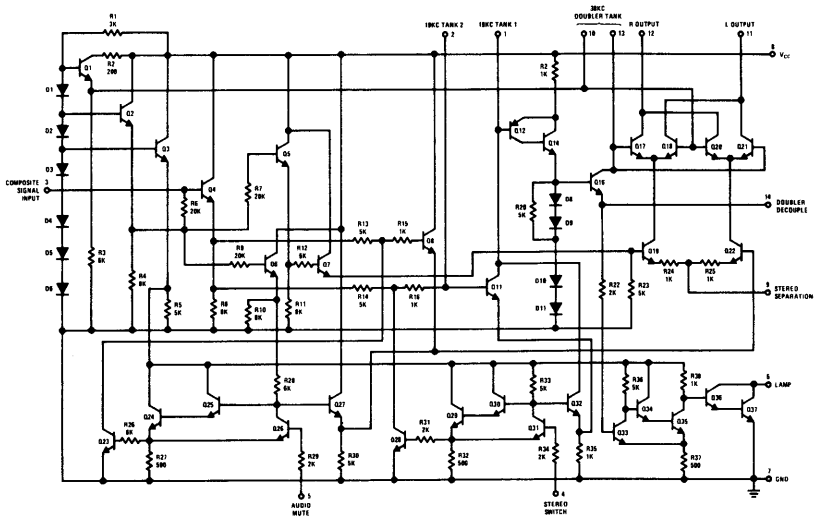

circuit schematics (con't)

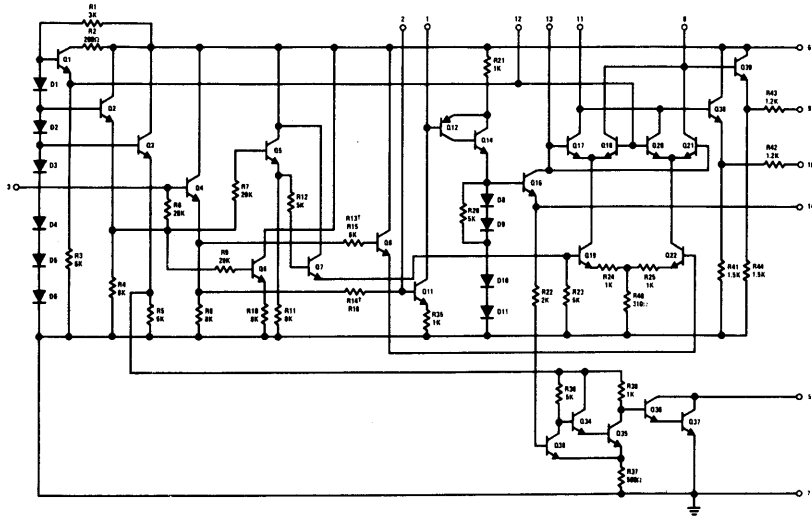

LM1307E

typical performance characteristics

Channel Separation vs V_{CC}

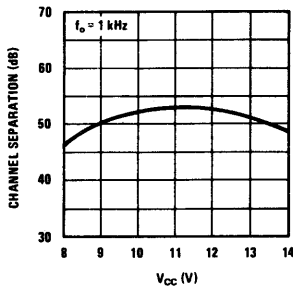

Channel Separation vs Composite Input Level

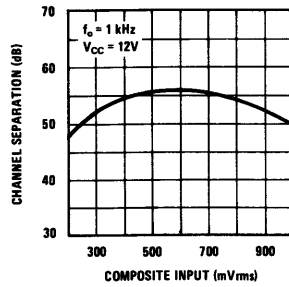

Total Harmonic Distortion vs Composite Input Level

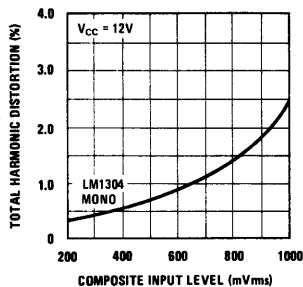

Multiplex Sensitivity vs 19 kHz Gain Adjustment

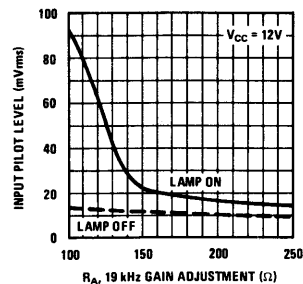

circuit configurations

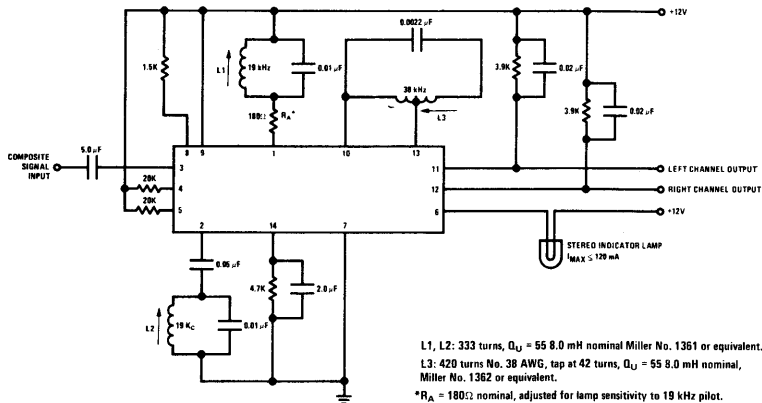

LM1304 Typical Circuit Configuration

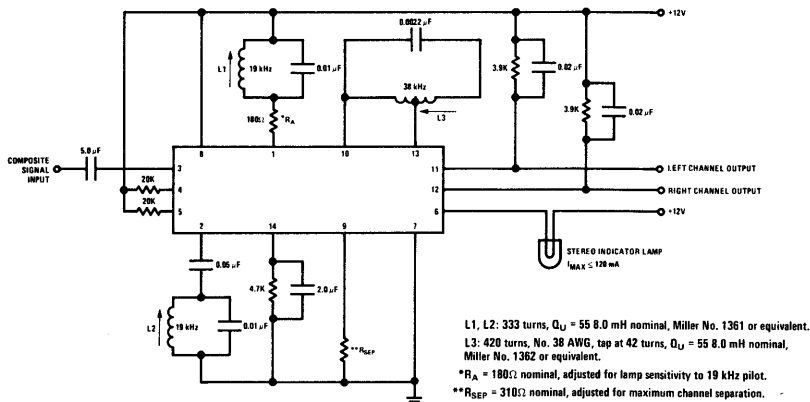

LM1305 Typical Circuit Configuration

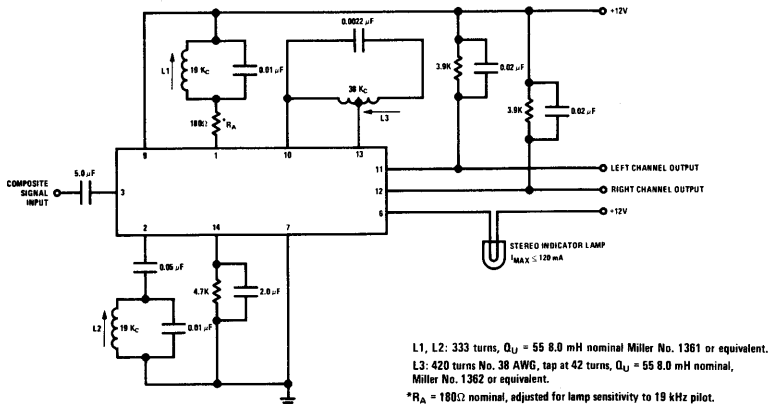

LM1307 Typical Circuit Configuration

circuit configurations (con't)

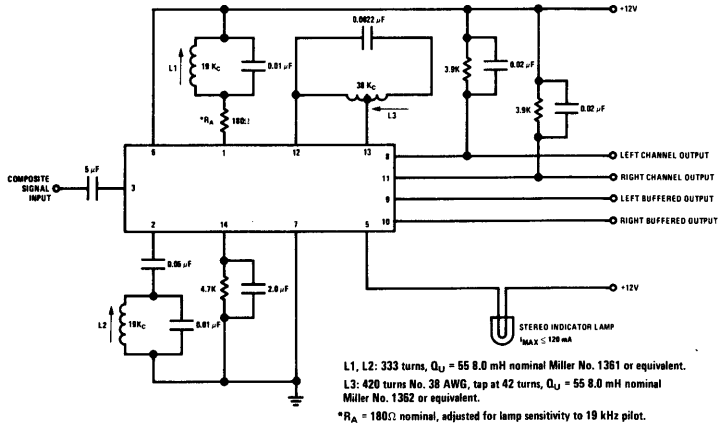

LM1307E Typical Circuit Configuration