

Pin 1 – ADJ.
 Pin 2 – V_{OUT}
 Case – V_{IN}

K Package – TO-3

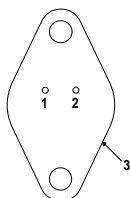

Pin 1 – ADJ.
 Pin 2 – V_{OUT}
 Case – V_{IN}

R Package – TO-66

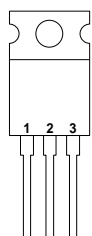

Pin 1 – ADJ.
 Pin 2 – V_{IN}
 Pin 3 – V_{OUT}
 Case – V_{IN}

T Package – TO-220

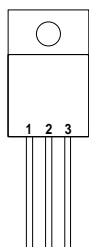

Pin 1 – ADJ.
 Pin 2 – V_{IN}
 Pin 3 – V_{OUT}
 Case – V_{IN}

G Package – TO-257

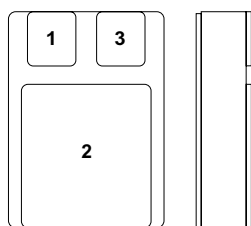

Pin 1 – ADJ.
 Pin 2 – V_{IN}
 Pin 3 – V_{OUT}

**SG Package – SMD1
CERAMIC SURFACE
MOUNT**

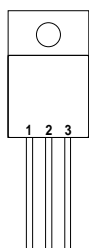

Pin 1 – ADJ.
 Pin 2 – V_{IN}
 Pin 3 – V_{OUT}

**IG Package – TO-257
(Isolated)**

1.5 AMP NEGATIVE ADJUSTABLE VOLTAGE REGULATOR

FEATURES

- **OUTPUT VOLTAGE RANGE OF:**
1.25 TO 40V FOR STANDARD VERSION
1.25 TO 50V FOR –HV VERSION
- **1% OUTPUT VOLTAGE TOLERANCE**
- **0.3% LOAD REGULATION**
- **0.01%/V LINE REGULATION**
- **COMPLETE SERIES OF PROTECTIONS:**
 - **CURRENT LIMITING**
 - **THERMAL SHUTDOWN**
 - **SOA CONTROL**

ABSOLUTE MAXIMUM RATINGS ($T_{case} = 25^{\circ}C$ unless otherwise stated)

V_{I-O}	Input - Output Differential Voltage	– Standard	40V
		– HV Series	50V
I_O	Output Current		Internally limited
P_D	Power Dissipation		Internally limited
T_j	Operating Junction Temperature Range		See Order Information Table
T_{stg}	Storage Temperature		-65 to 150°C

Parameter	Test Conditions	IP137A , IP137AHV LM137A , LM137AHV			IP137 , IP137HV LM137 , LM137HV			Units	
		Min.	Typ.	Max.	Min.	Typ.	Max.		
V _{REF} Reference Voltage	I _{OUT} = 10mA	-1.238	-1.25	-1.262	-1.225	-1.25	-1.275	V	
	I _{OUT} = 10mA to I _{MAX} V _{IN} - V _{OUT} = 3V to V _{MAX} P ≤ P _{MAX} T _J = -55 to 150°C	-1.220	-1.25	-1.280	-1.200	-1.250	-1.300	V	
$\frac{\Delta V_{OUT}}{\Delta I_{OUT}}$ Line Regulation 1	V _{IN} - V _{OUT} = 3V to V _{MAX} T _J = -55 to 150°C	0.005	0.010		0.010	0.020	%V		
			0.010	0.030		0.020		0.050	
$\frac{\Delta V_{OUT}}{\Delta I_{OUT}}$ Load Regulation 1	I _{OUT} = 10mA to I _{MAX}	V _{OUT} ≤ 5V	5	25	15	25	mV		
		V _{OUT} ≥ 5V	0.1	0.5	0.3	0.5	%		
	I _{OUT} = 10mA to I _{MAX} T _J = -55 to 150°C	V _{OUT} ≤ 5V	10	50	20	50	mV		
		V _{OUT} ≥ 5V	0.2	1	0.3	1	%		
Thermal Regulation	t _p = 10ms T _A = 25°C		0.002	0.020		0.002	0.02	%/W	
Ripple Rejection	V _{OUT} = -10V f = 120Hz	C _{ADJ} = 0	60	66		60		dB	
		C _{ADJ} = 10μF T _J = -55 to 150°C	70	80		66	77		dB
I _{ADJ} Adjust Pin Current	T _J = -55 to 150°C		65	100		65	100	μA	
ΔI_{ADJ} Adjust Pin Current Change	T _J = -55 to 150°C	I _{OUT} = 10mA to I _{MAX}		0.2	2		0.5	5	μA
		V _{IN} - V _{OUT} = 3V to 40V		1.0	5		2	5	
		V _{IN} - V _{OUT} = 3V to 50V (HV SERIES)		2.0	6		3	6	
I _{MIN} Minimum Load Current	T _J = -55 to 150°C	V _{IN} - V _{OUT} ≤ 40V		2.5	5		2.5	5	mA
		V _{IN} - V _{OUT} ≤ 10V		1.2	3		1.2	3	
I _{CL} Current Limit	T _J = -55 to 150°C	V _{IN} - V _{OUT} ≤ 15V	1.5	2.2	3.2	1.5	2.2	3.2	A
		V _{IN} - V _{OUT} = 40V	0.24	0.4	1	0.24	0.4		
		V _{IN} - V _{OUT} = 50V (HV SERIES)	0.2	0.4	0.8	0.2	0.4	0.8	
$\frac{\Delta V_{OUT}}{\Delta TEMP}$ Temperature Stability	T _J = -55 to 150°C		0.6	1.5		0.6		%	
$\frac{\Delta V_{OUT}}{\Delta TIME}$ Long Term Stability	T _A = +125°C t = 1000 Hrs		0.3	1		0.3	1	%	
e _n RMS Output Noise (% of V _{OUT})	f = 10 Hz to 10 kHz T _A = 25°C		0.003			0.003		%	
R _{θJC} Thermal Resistance Junction to Case	K Package		2.3	3		2.3	3	°C/W	
	R Package		5	7		5	7		
	G Package		3	5		3	5		

1) Regulation is measured at constant junction temperature, using pulse testing at a low duty cycle. Changes in output voltage due to heating effects are covered under thermal regulation specifications. Load regulation is measured at a point 1/8" from the bottom of the package for the TO-3 and TO-66 packages, at the junction of the wide and narrow portion of the output lead for the SMD1 package, and 1/8" below the base of the package on the output pin of the TO-257 package.

2) Test Conditions unless otherwise stated: V_{IN} - V_{OUT} = 5V , I_{OUT} = 0.5A , P_{MAX} = 20W , I_{MAX} = 1.5A
V_{MAX} = 40V for standard series , 50V for HV series.

Parameter	Test Conditions	IP337AHV			IP337HV LM337HV			Units	
		Min.	Typ.	Max.	Min.	Typ.	Max.		
V _{REF} Reference Voltage	I _{OUT} = 10mA	-1.238	-1.25	-1.262	-1.213	-1.25	-1.287	V	
	I _{OUT} = 10mA to I _{MAX} V _{IN} - V _{OUT} = 3V to V _{MAX} P ≤ P _{MAX} T _J = 0 to 125°C	-1.220	-1.25	-1.280	-1.200	-1.250	-1.300	V	
$\frac{\Delta V_{OUT}}{\Delta I_{OUT}}$ Line Regulation 1	V _{IN} - V _{OUT} = 3V to V _{MAX} T _J = 0 to 125°C	0.005	0.010		0.010	0.040	%V		
		0.010	0.030		0.020	0.070			
$\frac{\Delta V_{OUT}}{\Delta I_{OUT}}$ Load Regulation 1	I _{OUT} = 10mA to I _{MAX}	V _{OUT} ≤ 5V	5	25	15	50	mV		
		V _{OUT} ≥ 5V	0.1	0.5	0.3	1	%		
	I _{OUT} = 10mA to I _{MAX} T _J = 0 to 125°C	V _{OUT} ≤ 5V	10	50	20	70	mV		
		V _{OUT} ≥ 5V	0.2	1	0.3	1.5	%		
Thermal Regulation	t _p = 10ms T _A = 25°C	0.002	0.020		0.003	0.04	%/W		
Ripple Rejection	V _{OUT} = 10V f = 120Hz	C _{ADJ} = 0	60	66	60		dB		
		C _{ADJ} = 10μF T _J = 0 to 125°C	70	80	66	77	dB		
I _{ADJ} Adjust Pin Current	T _J = 0 to 125°C	65	100		65	100	μA		
ΔI_{ADJ} Adjust Pin Current Change	T _J = 0 to 125°C	I _{OUT} = 10mA to I _{MAX}	0.2	2	0.5	5	μA		
		V _{IN} - V _{OUT} = 3V to 40V	1.0	5	2	5			
		V _{IN} - V _{OUT} = 3V to 50V (HV SERIES)	2.0	6	3	6			
I _{MIN} Minimum Load Current	T _J = 0 to 125°C	V _{IN} - V _{OUT} ≤ 40V	2.5	5	2.5	10	mA		
		V _{IN} - V _{OUT} ≤ 10V	1.2	3	1	6			
I _{CL} Current Limit	T _J = 0 to 125°C	V _{IN} - V _{OUT} ≤ 15V	1.5	2.2	3.5	1.5	2.2	A	
		V _{IN} - V _{OUT} = 40V	0.24	0.4	1	0.15	0.4		
		V _{IN} - V _{OUT} = 50V (HV SERIES)	0.2	0.4	0.8	0.1	0.4		0.8
$\frac{\Delta V_{OUT}}{\Delta TEMP}$ Temperature Stability	T _J = 0 to 125°C	0.6	1.5		0.6		%		
$\frac{\Delta V_{OUT}}{\Delta TIME}$ Long Term Stability	t = 1000 Hrs	0.3	1		0.3	1	%		
e _n RMS Output Noise (% of V _{OUT})	f = 10 Hz to 10 kHz T _A = 25°C	0.003			0.003		%		
R _{θJC} Thermal Resistance Junction to Case	K Package	2.3	3		2.3	3	°C/W		
	T Package	4	5		4				

1) Regulation is measured at constant junction temperature, using pulse testing at a low duty cycle. Changes in output voltage due to heating effects are covered under thermal regulation specifications. Load regulation is measured at a point 1/8" from the bottom of the package for the TO-3 and TO-66 packages, at the junction of the wide and narrow portion of the output lead for the SMD1 package, and 1/8" below the base of the package on the output pin of the TO-257 package.

2) Test Conditions unless otherwise stated: V_{IN} - V_{OUT} = 5V, I_{OUT} = 0.5A, P_{MAX} = 20W, I_{MAX} = 1.5A
V_{MAX} = 40V for standard series, 50V for HV series.

APPLICATIONS INFORMATION

High Stability Regulator

The output stability, load regulation, line regulation, thermal regulation, temperature drift, long term drift, and noise, can be improved by a factor of 6.6 over the standard regulator configuration. This assumes a zener has 20PPM/°C maximum drift and about 10 times lower noise than the regulator.

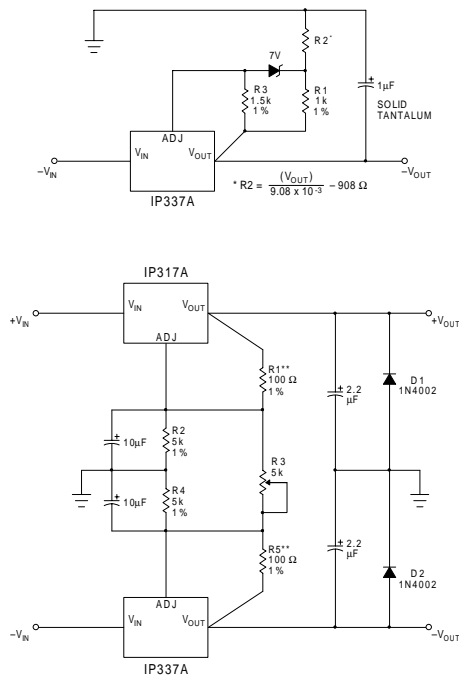

* Solid Tantalum
** R1 or R5 may be trimmed slightly to improve tracking.

Dual Tracking Supply

Multiple Tracking Regulators

In the application shown below, regulator #2 to "N" will track regulator #1 to within $\pm 24\text{mV}$ initially, and to $\pm 60\text{mV}$ over all load, line, and temperature conditions.

If any regulator output is shorted to ground, all other outputs will drop to -2V . Load regulation of regulators 2 to "N" will be improved by $V_{\text{OUT}} / 1.25\text{V}$ compared to a standard regulator, so regulator #1 should be the one which has the lowest load current.

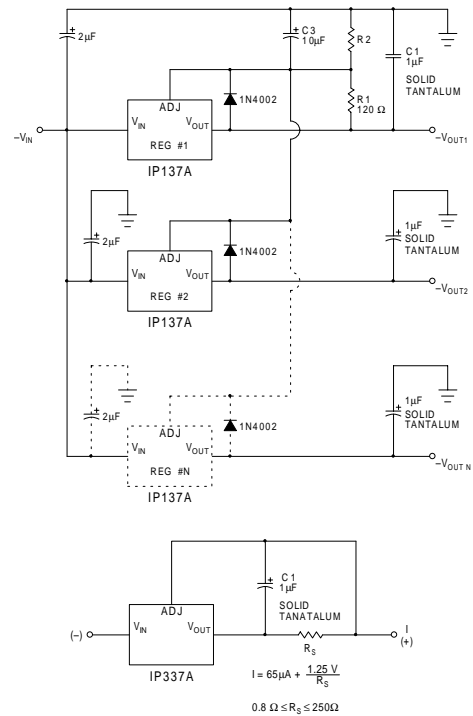

$$I = 65\mu\text{A} + \frac{1.25\text{V}}{R_5}$$

$$0.8\Omega \leq R_5 \leq 250\Omega$$

Current Regulator

Order Information

Part Number	K-Pack (TO-3)	R-Pack (TO-66)	IG-Pack G-Pack (TO-257)	T-Pack (TO-220)	SG-Pack SMD1	Temp. Range
LM137	✓	✓	✓		✓	-55 to +150°C
LM137HV	✓	✓	✓		✓	"
LM137A	✓	✓	✓		✓	"
LM137AHV	✓	✓	✓		✓	"
IP137	✓	✓	✓		✓	-55 to +150°C
IP137HV	✓	✓	✓		✓	"
IP137A	✓	✓	✓		✓	"
IP137AHV	✓	✓	✓		✓	"
LM337	✓			✓		0 to 125°C
LM337HV	✓			✓		0 to 125°C
IP337	✓			✓		0 to 125°C
IP337HV	✓			✓		"
IP337A	✓			✓		0 to 125°C
IP337AHV	✓			✓		"