

Product Specification

SPECIFICATION FOR APPROVAL

- () Preliminary Specification
- () Final Specification

Title	15.1" XGA TFT LCD
-------	-------------------

BUYER	
MODEL	

SUPPLIER	LG.Philips LCD CO., Ltd.
*MODEL	LM151X05
SUFFIX	A3C1

*When you obtain standard approval, please use the above model name without suffix

SIGNATURE	DATE
/	
/	
/	

Please return 1 copy for your confirmation with your signature and comments.

APPROVED BY	DATE
S. W. LEE / G.Manager	
REVIEWED BY	
S. G. Hong / Manager	
PREPARED BY	
S. S. Kim / Engineer	

**Product Engineering Dept.
LG. Philips LCD Co., Ltd**

Product Specification

NO.	ITEM	Page
-	COVER	1
-	CONTENTS	2
-	RECORD OF REVISIONS	3
1	GENERAL DESCRIPTION	4
2	ABSOLUTE MAXIMUM RATINGS	5
3	ELECTRICAL SPECIFICATIONS	6
3-1	ELECTRICAL CHARACTERISTICS	7
3-2	INTERFACE CONNECTIONS	8
3-3	SIGNAL TIMING SPECIFICATIONS	9
3-4	SIGNAL TIMING WAVEFORMS	10
3-5	COLOR INPUT DATA REFERENCE	11
3-6	POWER SEQUENCE	12
4	OPTICAL SPECIFICATIONS	14
5	MECHANICAL CHARACTERISTICS	17
6	RELIABILITY	21
7	INTERNATIONAL STANDARDS	22
7-1	SAFETY	22
7-2	EMC	22
8	PACKING	23
8-1	DESIGNATION OF LOT MARK	23
8-2	PACKING FORM	23
9	PRECAUTIONS	24

Product Specification

RECORDS OF REVISIONS

Revision No	Revision No	Page	DESCRIPTION
Ver 0.0	Mar. 02, 2001	-	First Draft, Preliminary Specification

Product Specification

1. General Description

The LM151X05 is a Color Active Matrix Liquid Crystal Display with an integral Cold Cathode Fluorescent Lamp(CCFL) backlight system. The matrix employs a-Si Thin Film Transistor as the active element. It is a transmissive type display operating in the normally white mode. This TFT-LCD has 15.1 inches diagonally measured active display area with XGA resolution(768 vertical by 1024 horizontal pixel array) Each pixel is divided into Red, Green and Blue sub-pixels or dots which are arranged in vertical stripes. Gray scale or the brightness of the sub-pixel color is determined with a 6-bit gray scale signal for each dot, thus, presenting a palette of more than 262,144 colors.

The LM151X05 has been designed to apply the TTL interface method.

The LM151X05 LCD is intended to support applications where high response time, wide viewing angle, high color saturation, and high color depth are very important.

In combination with the vertical arrangement of the sub-pixels, theLM151X05 characteristics provide an excellent flat panel display for office automation products such as monitors.

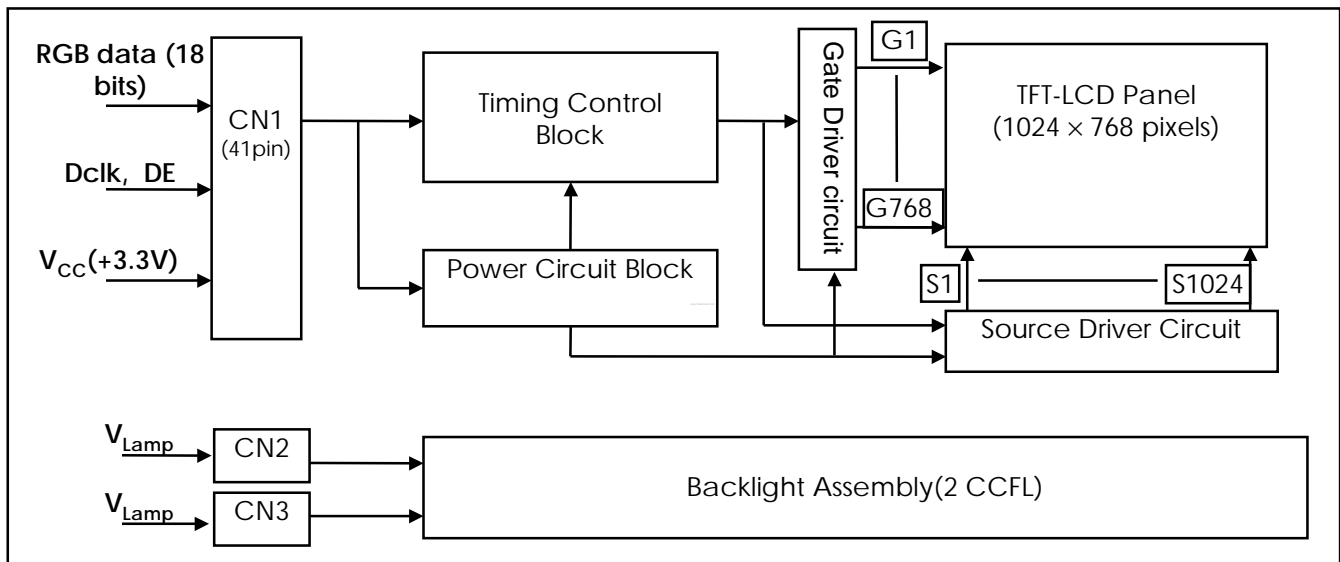

General Features

Active screen size	15.1 inches(307.2 x 230.4mm) diagonal
Outline Dimension	352.0(H) x 263.5(V) x 14.0(D) mm(Typ.) without user connector
Pixel Pitch	0.300 mm x 0.300mm
Pixel format	1024 horiz. By 768 vert. Pixels RGB stripes arrangement
Color depth	6-bit, 262,144 colors
Luminance, white	200 cd/m ² (Typ.)
Power Consumption	1.6 Watts Logic / 8.6 Watts CCFL (Typ. With chess 8x6 pattern)
Weight	1150g(Typ.)
Display operating mode	Transmissive mode, normally white
Surface treatments	Hard coating(3H) Anti-glare treatment of the front polarizer

Product Specification

2. Absolute Maximum Ratings

The following are maximum values which, if exceeded, may cause operation or damage to the unit.

Table 1. ABSOLUTE MAXIMUM RATINGS

Parameter	symbol	Values		Units	Notes
		Min.	Max.		
Power Input Voltage	V_{CC}	-0.3	4.0	Vdc	At $25 \pm 5^\circ\text{C}$
Input Signal Voltage	V_i	-0.3	$V_{CC}+0.3$	Vdc	
Operating Temperature	T_{OP}	0	50	$^\circ\text{C}$	1
Storage Temperature	T_{ST}	-20	60	$^\circ\text{C}$	1
Operating Ambient Humidity	H_{OP}	10	90	%RH	1
Storage Humidity	H_{ST}	10	90	%RH	1

Note : 1. Temperature and relative humidity range are shown in the figure below.
Wet bulb temperature should be 39°C Max, and no condensation of water.

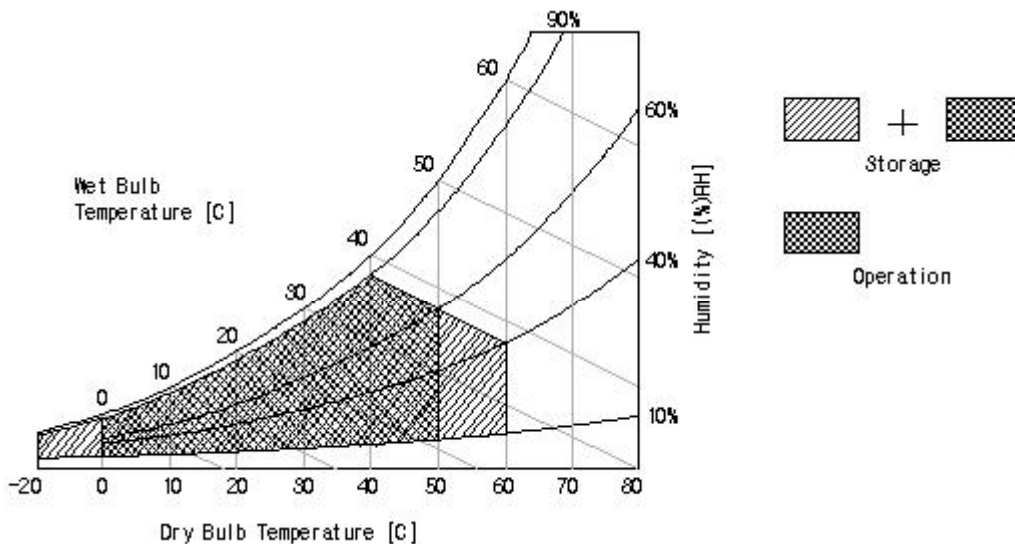

Product Specification

3. Electrical Specifications

3-1. Electrical Characteristics

The LM151X05 requires two power inputs. One is employed to power the LCD electronics and to drive the TFT array and liquid crystal. The second input which powers the CCFL, is typically generated by an inverter. The inverter is an external unit to the LCD.

Table 2. ELECTRICAL CHARACTERISTICS

Parameter	Symbol	Values			Units	Notes
		Min.	Typ.	Max.		
MODULE :						
Power Supply Input Voltage	V_{CC}	3.15	3.3	3.45	Vdc	
Power Supply Input Current	I_{CC}	420	485	550	mA	1
Power Consumption	P_C	1.2	1.6	2.0	Watts	1
Rush Current	I_{RUSH}		-	2.5	A	2
LAMP :						
Operating Voltage	V_{BL}	520(9mA)	540(8mA)	660(3mA)	V_{RMS}	3
Operating Current	I_{BL}	3.0	8.0	9.0	mA	
Established Starting Voltage	V_S					4
at 25 °C		-	-	850	V_{RMS}	
at 0 °C		-	-	1100	V_{RMS}	
Operating Frequency	f_{BL}	45	60	80	kHz	5
Discharge Stabilization Time	T_S			3	Minutes	6
Power Consumption	P_{BL}	-	8.6	9.5	Watts	7
Life Time		30,000	-	-	Hrs	8

Note. The design of the inverter must have specifications for the lamp in LCD Assembly.

The performance of the Lamp in LCM, for example life time or brightness, is extremely influenced by the characteristics of the DC-AC Inverter. So all the parameters of an inverter should be carefully designed so as not to produce too much leakage current from high-voltage output of the inverter.

When you design or order the inverter, please make sure unwanted lighting caused by the mismatch of the lamp and the inverter(no lighting,flicker,etc) never occurs.When you confirm it,the LCD Assembly should be operated in the same condition as installed in your instrument.

Note. Do not attach a conducting tape to lamp connecting wire.. If the lamp wire attach to conducting tape, TFT-LCD Module have a low luminance and the inverter has abnormal action because leakage current occurs between lamp wire and conducting tape.

1. The specified current and power consumption are under the $V_{CC}=3.3V$, $25^{\circ}C$, $f_v=60Hz$ condition whereas full black pattern is displayed and f_v is the frame frequency.
2. The duration of rush current is about 20ms.
3. The variance of the voltage is $\pm 10\%$.
4. The voltage above V_{BS} should be applied to the lamps for more than 1second for start-up. Otherwise,the lamps may not be turned on.

Product Specification

5. The output of the inverter must have symmetrical(negative and positive) voltage waveform and symmetrical current waveform.(Unsymmetrical ratio is less than 10%) Please do not use the inverter which has unsymmetrical voltage and unsymmetrical current and spike wave.
Lamp frequency may produce interference with horizontal synchronous frequency and as a result this may cause beat on the display. Therefore lamp frequency shall be as away as possible from the horizontal synchronous frequency and from its harmonics in order to prevent interference.
6. Let 's define the brightness of the lamp after being lighted for 5 minutes as 100%.
 T_s is the time required for the brightness of the center of the lamp to be not less than 95%.
The used lamp current is the lamp typical current.
7. The lamp power consumption shown above does not include loss of external inverter.
The used lamp current is the lamp typical current.
8. The life time is determined as the time at which brightness of lamp is 50% compared to that of initial value at the typical lamp current on condition of continuous operating at 25 ± 2 .

Product Specification

3-2. Interface Connections

This LCD employs three interface connections, a 41 pin connector is used for the module electronics and two connectors, s three pin connector, are used for the integral backlight system. The electronics interface connector is a model DF9B-41P-1V manufactured by Hirose and. the pin configuration for the connector is shown in the table below.

(LCD Connector : DF9B-41P-1V or equivalent, Mating Connector : DF9B-41S-1V or equivalent)

Table 3. MODULE CONNECTOR PIN CONFIGURATION

Pin	Symbol	Description	Pin	Symbol	Description
1	GND	System Ground. Note 1	2	DCLK	Data Input Clock
3	GND	System Ground	4	H _{sync}	H _{sync} -(Horizontal Sync.) or Ground
5	V _{sync}	V _{sync} -(Vertical Sync.) or Ground	6	GND	System Ground
7	GND	System Ground	8	GND	System Ground
9	R0	Red data 0 (LSB)	10	R1	Red data 1
11	R2	Red data 2	12	GND	System Ground
13	R3	Red data 3	14	R4	Red data 4
15	R5	Red data 5 (MSB)	16	GND	System Ground
17	GND	System Ground	18	GND	System Ground
19	G0	Green data 0 (LSB)	20	G1	Green data 1
21	G2	Green data 2	22	GND	System Ground
23	G3	Green data 3	24	G4	Green data 4
25	G5	Green data 5 (MSB)	26	GND	System Ground
27	GND	System Ground	28	GND	System Ground
29	B0	Blue data 0 (LSB)	30	B1	Blue data 1
31	B2	Blue data 2	32	GND	System Ground
33	B3	Blue data 3	34	B4	Blue data 4
35	B5	Blue data 5 (MSB)	36	GND	System Ground
37	DE	Data Enable Signal	38	V _{CC}	Power Supply for LCD Module
39	V _{CC}	Power Supply for LCD Module	40	V _{CC}	Power Supply for LCD Module
41	V _{CC}	Power Supply for LCD Module			

- Notes:
1. All GND(ground) pins should be connected together and to V_{SS} which should also be connected to the LCD's metal frame.
 2. All V_{CC}(power input) pins should be connected together.
 3. Because This LCM operates in Data Enable signal only mode, that is no problem whether H_{sync}. And V_{sync}. Signals are applied or connected with Ground.

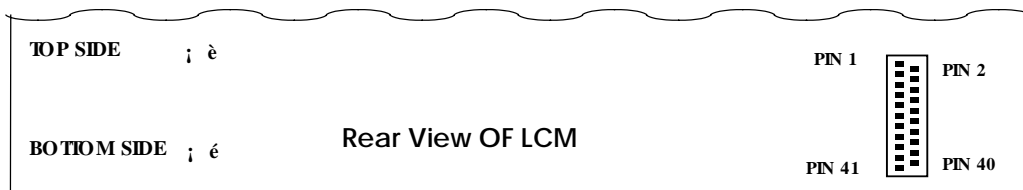

The backlight interface connector is a model BHR-03VS-1, manufactured by JST. The mating connector part number is SM02(8.0)B-BHS-1-TB or equivalent. The pin configuration for the connector is shown in the table below.

Table 4 BACKLIGHT CONNECTOR PIN CONFIGURATION

Pin	Symbol	Description	Notes
1	HV	Lamp power input (High)	1
2	NC	No connect	
3	LV	Lamp power input (Low)	

Notes: 1. The input power terminal (High) is colored pink.

Product Specification

3-3. Signal Timing Specifications

This is the signal timing required at the input of the User connector. All of the interface signal timing should be satisfied with the following specifications for its proper operation.

Table 5. TIMING TABLE

ITEM	SYMBOL		MIN.	TYP.	MAX.	UNIT	NOTE	
Dclk	Frequency	f _{CLK}	50	65	79	§ Ö		
	Width-Low	t _{wCL}	3	-	-	§ Å		
	Width-High	t _{wCH}	3	-	-	§ Å		
	Duty	D	0.4	0.5	0.6		D=t _{CLKH} /t _{CLK}	
Hsync	Period	t _{HP}	1056	1344	1368	t _{CLK}	1	
	Width-Active	t _{WH}	8	136	-			
Vsync	Period	t _{VP}	777	806	-	t _{HP}	1	
	Width active	t _{wV}	2	6	-			
DTMG	Set up Time	t _{SI}	3	-	-	§ Å	for DCLK	
	Hold Time	t _{HI}	3	-	-			
	Horizontal Back Porch	t _{HBP}	8	168	-	t _{CLK}	2	
	Horizontal Front Porch	t _{HFP}	8	24	-			
	Vertical Back Porch	t _{VBP}	5	29	-	t _{HP}		
	Vertical Front Porch	t _{VFP}	2	3	-			
DATA	Set up Time	t _{SD}	2.5	-	-	§ Å		for DCLK
	Hold Time	t _{HD}	1.5	-	-			

Notes

1. Because this LCM operates in Data Enable signal only mode, that is no problem whether Hsync. And Vsync. Signals are inserted or connected with
2. If Data Enable signal is abnormally applied to the user connector of LCM, The displ. LCM is black.

Product Specification

3-4. Signal Timing Waveforms

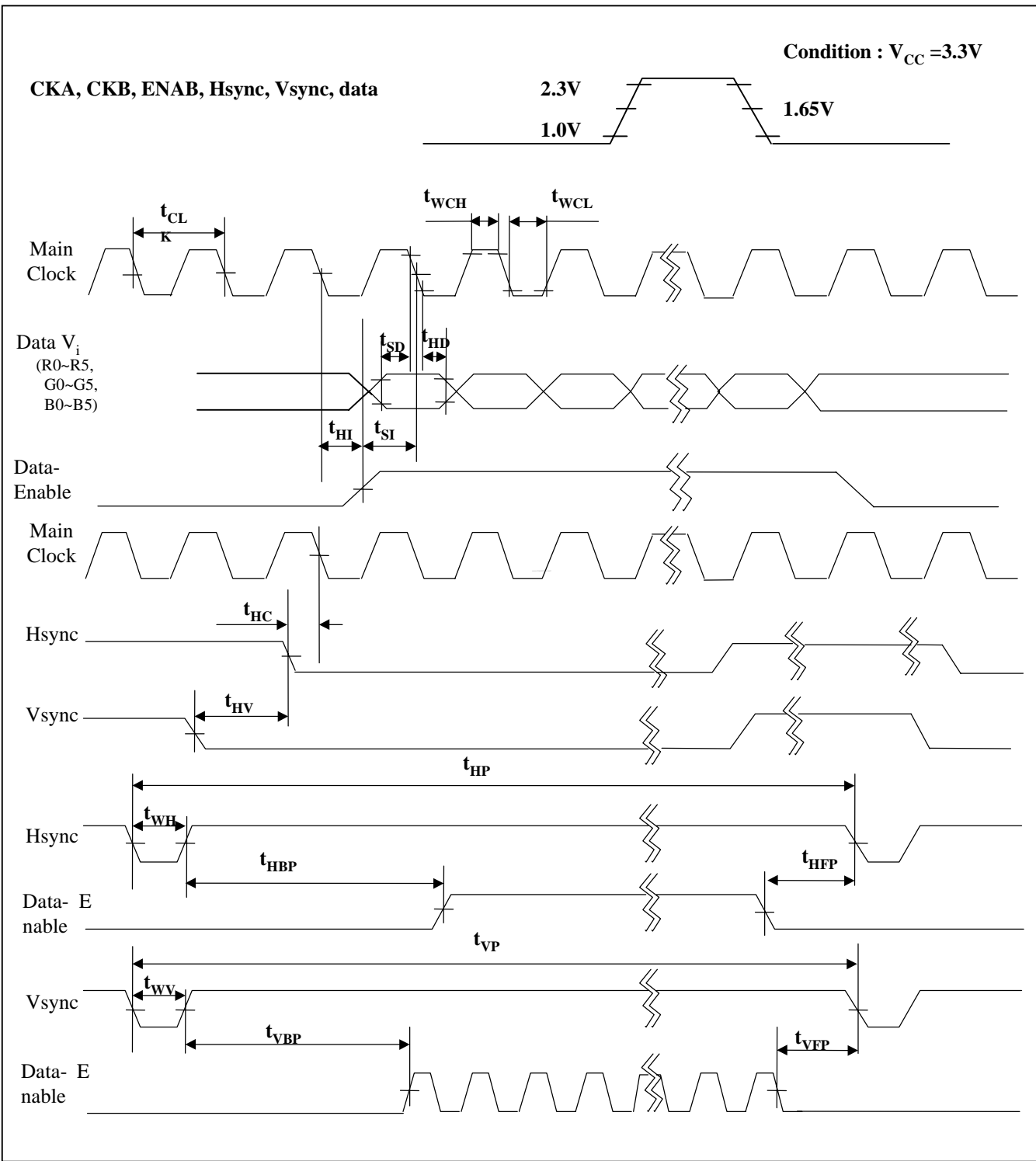

Product Specification

3-5. Color Input Data Reference

The brightness of each primary color(red,green and blue) is based on the 6-bit gray scale data input for the color ; the higher the binary input, the brighter the color. The table below provides a reference for color versus data input.

Table 6. COLOR DATA REFERENCE

Color		Input Color Data																
		Red						Green						Blue				
		MSB			LSB			MSB			LSB			MSB		LSB		
		R5	R4	R3	R2	R1	R0	G5	G4	G3	G2	G1	G0	B5	B4	B3	B2	B1
Basic Colors	Black	0	0	0	0	0	0	0	0	0	0	0	0	0	0	0	0	0
	Red(63)	1	1	1	1	1	1	0	0	0	0	0	0	0	0	0	0	0
	Green(63)	0	0	0	0	0	0	1	1	1	1	1	1	0	0	0	0	0
	Blue(63)	0	0	0	0	0	0	0	0	0	0	0	0	1	1	1	1	1
	Cyan	0	0	0	0	0	0	1	1	1	1	1	1	1	1	1	1	1
	Magenta	1	1	1	1	1	1	0	0	0	0	0	0	1	1	1	1	1
	Yellow	1	1	1	1	1	1	1	1	1	1	1	1	0	0	0	0	0
	White	1	1	1	1	1	1	1	1	1	1	1	1	1	1	1	1	1
Red	Red(00) Dark	0	0	0	0	0	0	0	0	0	0	0	0	0	0	0	0	0
	Red(01)	0	0	0	0	0	1	0	0	0	0	0	0	0	0	0	0	0
	Red(02)	0	0	0	0	1	0	0	0	0	0	0	0	0	0	0	0	0
	:	:	:	:	:	:	:	:	:	:	:	:	:	:	:	:	:	:
	Red(61)	1	1	1	1	0	1	0	0	0	0	0	0	0	0	0	0	0
	Red(62)	1	1	1	1	1	0	0	0	0	0	0	0	0	0	0	0	0
	Red(63) Bright	1	1	1	1	1	1	0	0	0	0	0	0	0	0	0	0	0
Green	Green(00)Dark	0	0	0	0	0	0	0	0	0	0	0	0	0	0	0	0	0
	Green(01)	0	0	0	0	0	0	0	0	0	0	0	1	0	0	0	0	0
	Green(02)	0	0	0	0	0	0	0	0	0	0	1	0	0	0	0	0	0
	:	:	:	:	:	:	:	:	:	:	:	:	:	:	:	:	:	:
	Green(61)	0	0	0	0	0	0	1	1	1	1	0	1	0	0	0	0	0
	Green(62)	0	0	0	0	0	0	1	1	1	1	1	0	0	0	0	0	0
	Green(63)Bright	0	0	0	0	0	0	1	1	1	1	1	1	0	0	0	0	0
Blue	Blue(00) Dark	0	0	0	0	0	0	0	0	0	0	0	0	0	0	0	0	0
	Blue(01)	0	0	0	0	0	0	0	0	0	0	0	0	0	0	0	0	1
	Blue(02)	0	0	0	0	0	0	0	0	0	0	0	0	0	0	0	1	0
	:	:	:	:	:	:	:	:	:	:	:	:	:	:	:	:	:	:
	Blue(61)	0	0	0	0	0	0	0	0	0	0	0	0	1	1	1	1	0
	Blue(62)	0	0	0	0	0	0	0	0	0	0	0	0	1	1	1	1	1
	Blue(63) Bright	0	0	0	0	0	0	0	0	0	0	0	0	1	1	1	1	1

Product Specification

3-6. Power Sequence

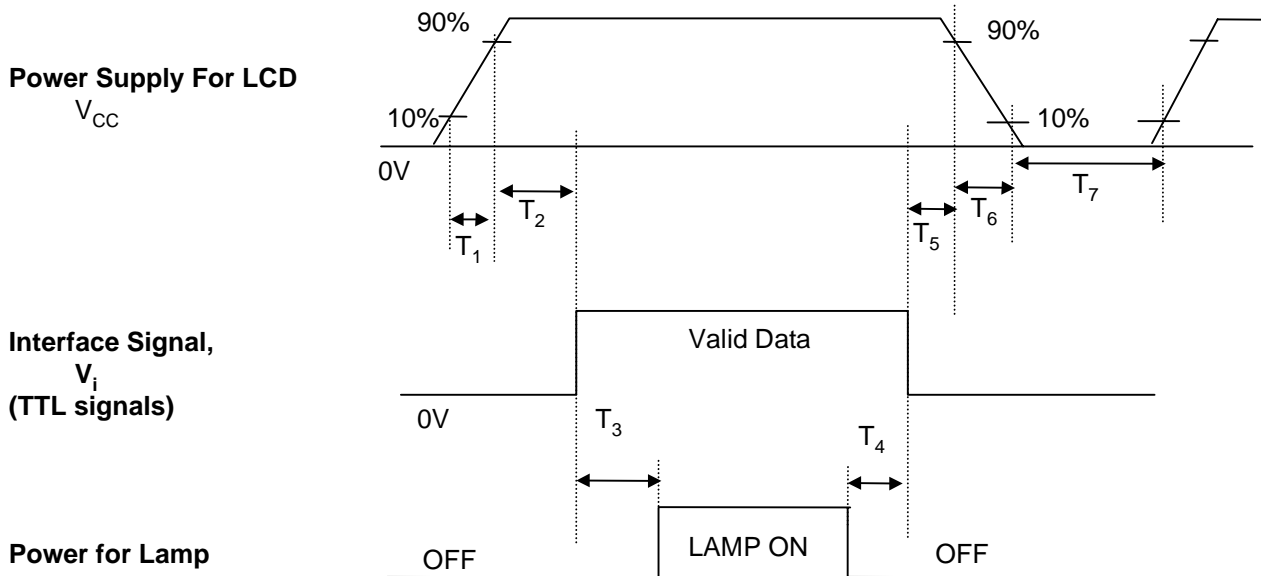

Parameter	Values			Units
	Min.	Typ.	Max.	
T_1	-	-	20	ms
T_2	0	-	50	ms
T_3	300	-	-	ms
T_4	300	-	-	ms
T_5	0	-	50	ms
T_6	-	-	20	ms
T_7	500	-	-	ms

- Notes :
1. Please avoid floating state of interface signal at invalid period.
 2. When the interface signal is invalid, be sure to pull down the power supply for LCD V_{CC} to 0V.
 3. Lamp power must be turn on after power supply for LCD and interface signal are valid.

Product Specification

4. Optical Specification

Optical characteristics are determined after the unit has been 'ON' and stable for approximately 30 minutes in a dark environment at 25 °C. The values specified are at an approximate distance 50cm from the LCD surface at a viewing angle of Φ and θ equal to 0 °.

FIG. 1 presents additional information concerning the measurement equipment and method.

FIG. 1 Optical Characteristic Measurement Equipment and Method

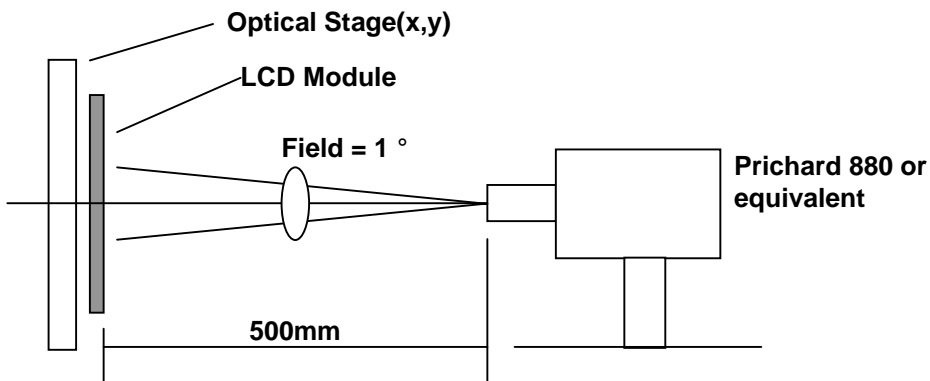

(Ta=25 °C, V_{CC}=3.3V, f_V=60Hz
Dclk=65MHz, I_{BL}=8mA)

Table 7. OPTICAL CHARACTERISTICS

Parameter	Symbol	Values			Units	Notes
		Min.	Typ.	Max.		
Contrast Ratio	CR	200	300	-		1
Surface Luminance, white	L _{WH}	160	200	-	cd/m ²	2
Luminance Variation	δ_{WHITE}	-	-	1.7		3
Luminance Uniformity-Angular Dependent (TCO99)	L _R	-	-	1.7		4
Response Time	Tr				ms	5
Rise Time	Tr _R	-	7	15		
Decay Time	Tr _D	-	18	30		
CIE Color Coordinates						
Red	XR	0.593	0.623	0.653		
	YR	0.307	0.337	0.367		
Green	XG	0.272	0.302	0.332		
	YG	0.555	0.585	0.615		
Blue	XB	0.116	0.146	0.176		
	YB	0.078	0.108	0.138		
White	XW	0.283	0.313	0.343		
	YW	0.299	0.329	0.359		
Viewing Angle					degree	
x axis, right($\phi=0^\circ$)	θ_r	70	75	-		6
x axis, left ($\phi=180^\circ$)	θ_l	70	75	-		
y axis, up ($\phi=90^\circ$)	θ_u	50	55	-		
y axis, down ($\phi=270^\circ$)	θ_d	55	60	-		
Gray Sclae	-	-	-	-		7

Product Specification
Notes :

1. Contrast Ratio(CR) is defined mathematically as :

$$\text{Contrast Ratio} = \frac{\text{Surface Luminance with all white pixels}}{\text{Surface Luminance with all black pixels}}$$

2. Surface luminance is the center point across the LCD surface 50cm from the surface with all pixels displaying full white. For more information see FIG 2.
 When $I_{BL}=8\text{mA}$, $L_{WH}=160\text{cd/m}^2(\text{Min.})$ $200\text{cd/m}^2(\text{Typ.})$

3. The variation in surface luminance, δ WHITE is determined by measuring L_{ON} at each test position 1 through 13, and then dividing the maximum L_{ON} of 13 points luminance by minimum L_{ON} of 13 points luminance. For more information see FIG 2.

$$\delta \text{ WHITE} = \text{Maximum}(L_{ON1}, L_{ON2}, \dots, L_{ON13}) \div \text{Minimum}(L_{ON1}, L_{ON2}, \dots, L_{ON13})$$

- 4 Luminance Uniformity-Angular Dependent (L_R) : TCO '99.
 TCO '99 Certification Requirements and test methods for environmental labeling of Display [Flat]report No.2 (X1.5.2 Luminance Uniformity)
 - Measure Pattern : 80% White Pattern (50Gray Level Pattern(L50))
 - Measure Point : 2Point(Point L & R) -Luminance : 125 cd/m²
 - Measure Distance : 57
 - Measure Method : Measure Luminance at each measure Point 2EA at the angle of +30deg. and -30deg.
 - Calculate the L_R Value :

$$L_R = ((L_{\text{max},+30\text{deg.}} / L_{\text{min},+30\text{deg.}}) + (L_{\text{max},-30\text{deg.}} / L_{\text{min},-30\text{deg.}})) / 2$$

5. Response time is the time required for the display to transition from to black(Rise Time, Tr_R) and from black to white(Decay Time, Tr_D). For additional information see FIG 4.

6. Viewing angle is the angle at which the contrast ratio is greater than 5.
 The angles are determined for the horizontal or x axis and the vertical or y axis with respect to the z axis which is normal to the LCD surface. For more information see FIG 5.

7. Gray scale specification

Gray Level	Luminance(%) (Typ.)
L0	0.30
L7	0.80
L15	3.99
L23	10.78
L31	21.0
L39	34.9
L47	53.5
L55	75.5
L63	100

Product Specification

FIG. 2 Luminance

<measuring point for luminance variation>

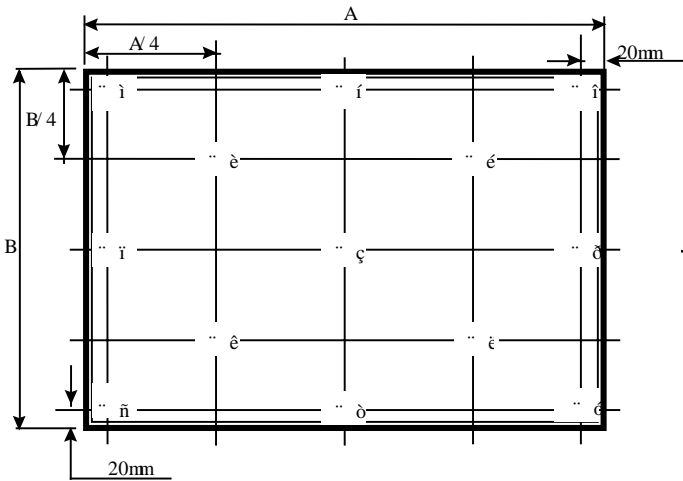

<measuring point for surface luminance>

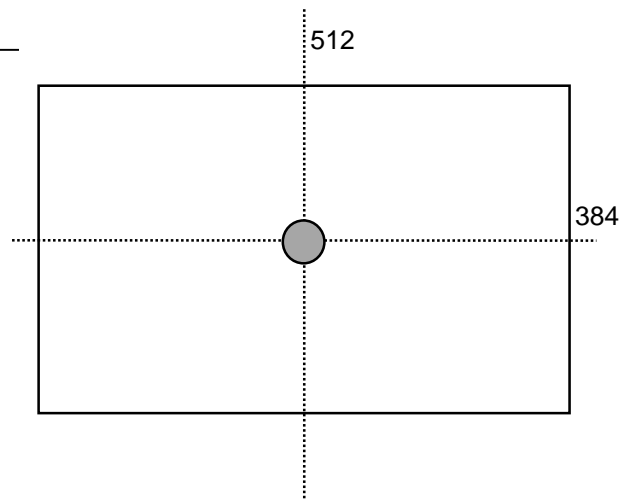
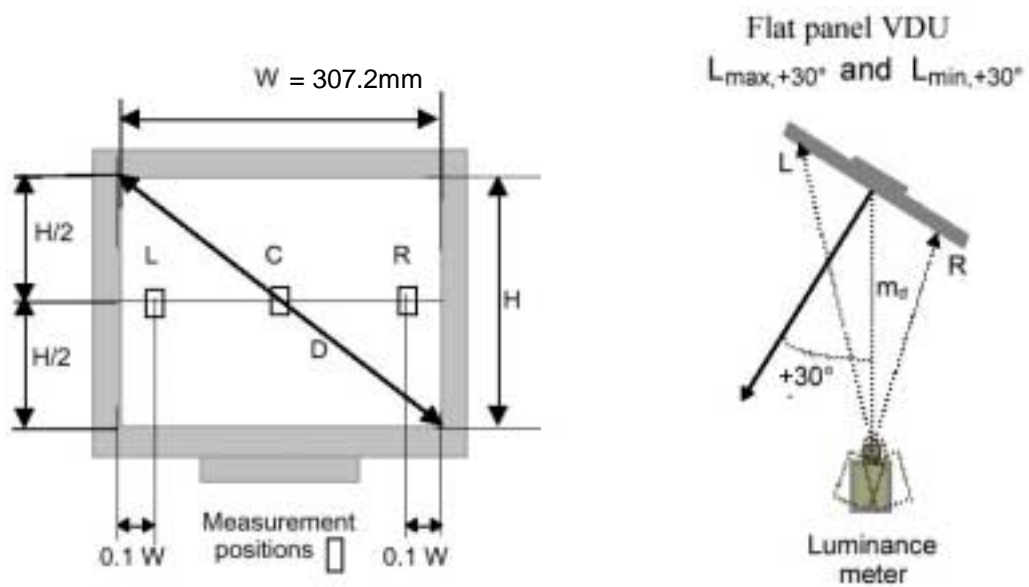

FIG. 3 Luminance Uniformity-Angular Dependent(TCO 99)



Product Specification

FIG. 4 Response Time

The response time is defined as the following figure and shall be measured by switching the input signal for "black" and "white".

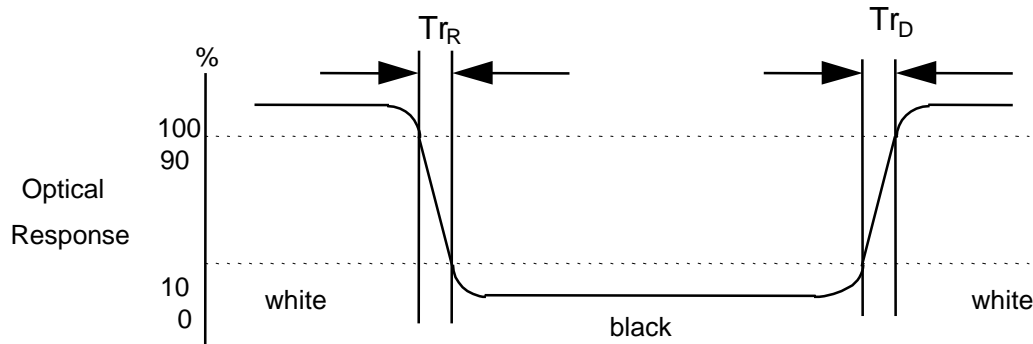
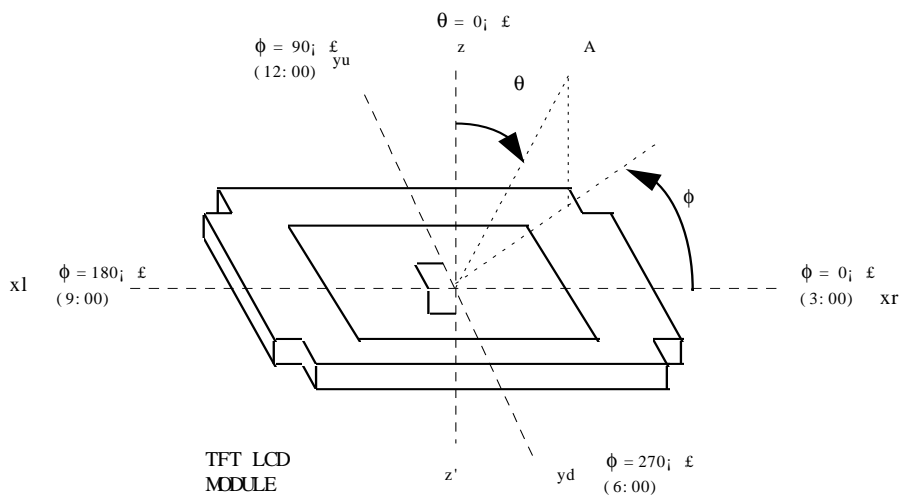

FIG. 5 Viewing angle



<dimension of viewing angle range>

Product Specification

5. Mechanical Characteristics

The contents provide general mechanical characteristics for the model LM151X05. In addition the figures in the next page are detailed mechanical drawing of the LCD.

Outside dimensions	Horizontal	352.0 ± 0.5mm
	Vertical	263.5 ± 0.5mm
	Depth	14.0 ± 0.5mm
Bezel area	Horizontal	311.2 ± 0.5mm
	Vertical	234.4 ± 0.5mm
Active display area	Horizontal	307.2mm
	Vertical	230.4mm
Weight(approximate)	1,150g(Typ.), 1,210g(Max.)	
Surface Treatment	Hard coating(3H) Anti-glare treatment of the front polarizer Haze(13%)	

Product Specification

<FRONT VIEW>

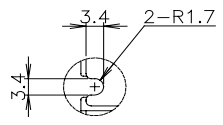
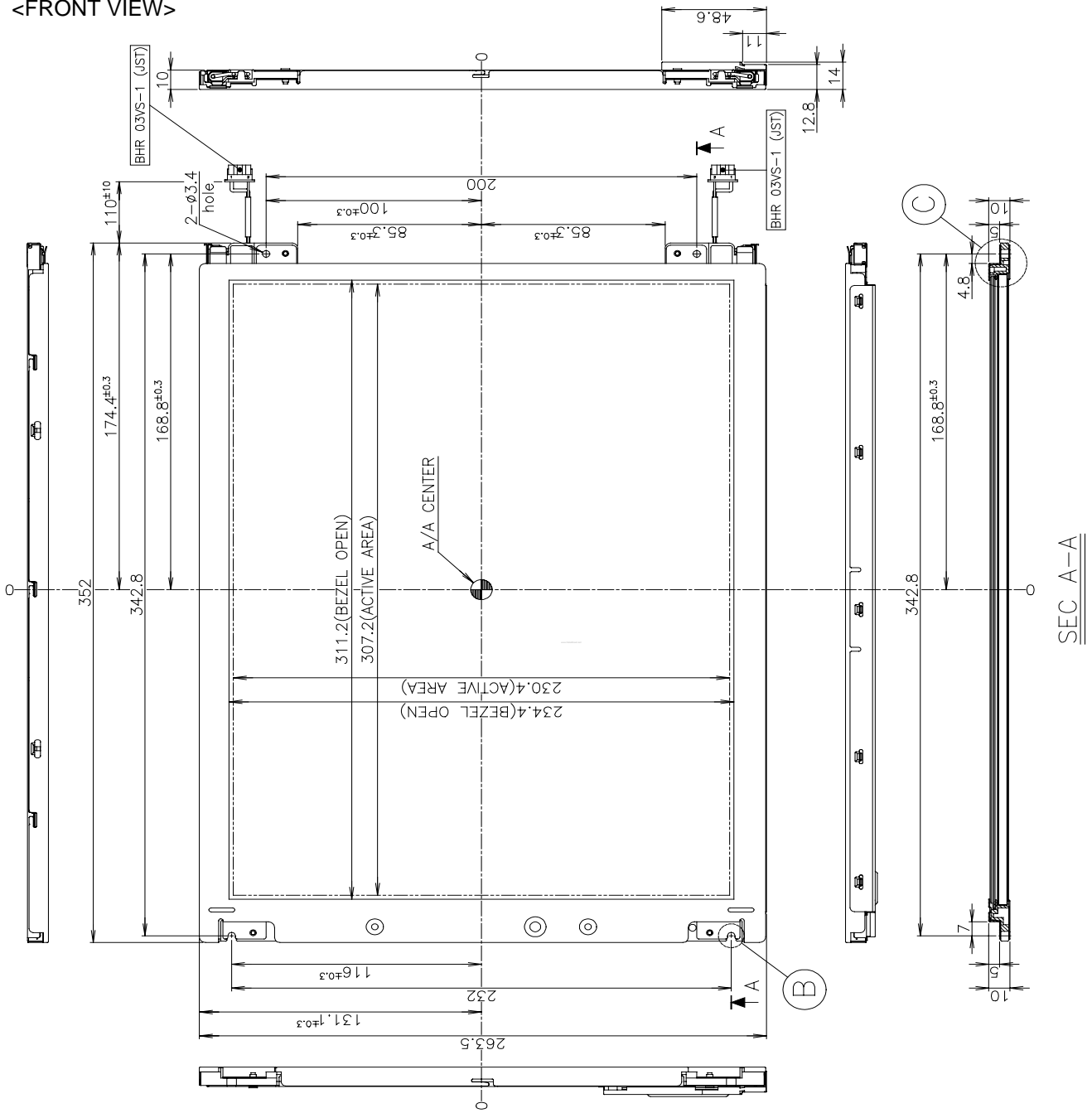

DETAIL "B"
TWO PIECES

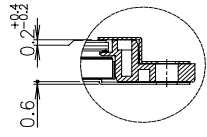

DETAIL "C"

Product Specification

<REAR VIEW>

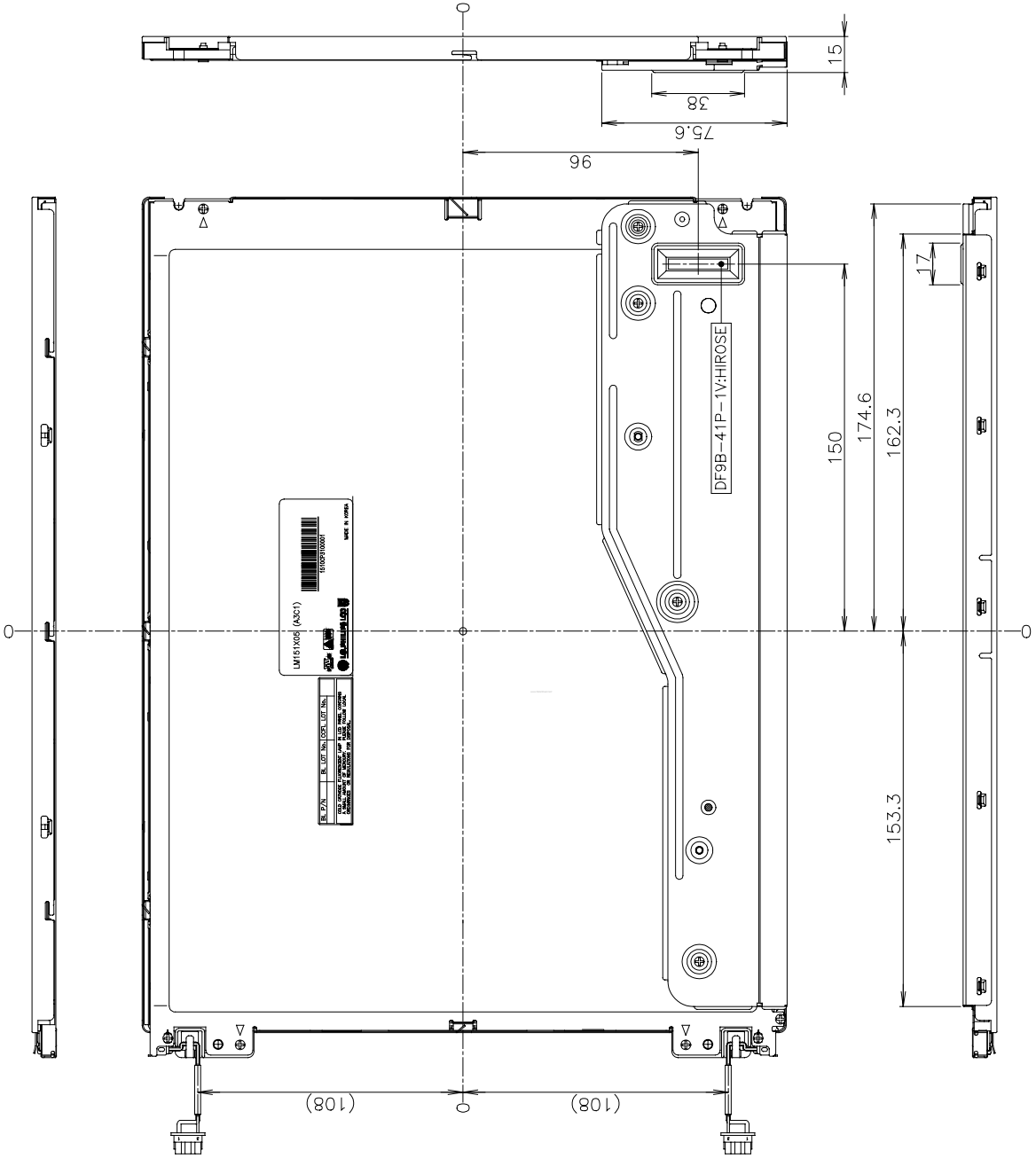

- NOTES
1. UNSPECIFIED TOLERANCE IS ± 0.5 .
 2. GAP BETWEEN TOP CASE AND GLASS IS $0.2^{+0.4}_{-0.2}$.
 3. TILT AND A PARTIAL DISPOSITION TOLERANCE OF DISPLAY AREA ARE AS FOLLOWS.
 - 1) X-DIRECTION : $|A-B| \leq 1.0\text{mm}$.
 - 2) Y-DIRECTION : $|C-D| \leq 1.0\text{mm}$.
 4. THE SAME SHAPE HAS THE SAME DIMENSION.

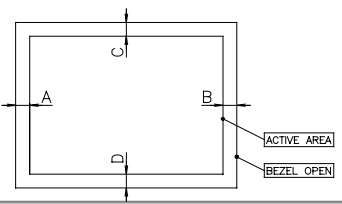

Product Specification

6. Reliability

Environment test condition

No.	Test Item	Conditions
1	High temperature storage test	Ta= 60°C 240h
2	Low temperature storage test	Ta= -20°C 240h
3	High temperature operation test	Ta= 50°C 50%RH 240h
4	Low temperature operation test	Ta= 0°C 240h
5	Vibration test (non-operating)	Waveform : Random Vibration : 1.0G RMS Bandwidth : 10 ~ 500Hz Direction : X, Y, Z Duration : 20min one time each direction.
6	Shock test (non-operating)	Waveform : Half sine wave,2ms Shock level : 120G Direction : ±X, ±Y, ±Z one time each direction.
7	Altitude operating storage / shipment	0 - 10,000 feet(3048m) 0 - 40,000 feet(12,192m)

{ Result Evaluation Criteria }

There should be no change which might affect the practical display function when the display quality test is conducted under normal operating condition.

Product Specification

7. International Standards

7-1. Safety

- a) UL 1950 Third Edition, Underwriters Laboratories, Inc. Jan. 28, 1995.
Standard for Safety of Information Technology Equipment Including Electrical Business Equipment.
- b) CAN/CSA C22.2 No. 950-95 Third Edition, Canadian Standards Association, Jan. 28, 1995.
Standard for Safety of Information Technology Equipment Including Electrical Business Equipment.
- c) EN 60950 : 1992+A1: 1993+A2: 1993+A3: 1995+A4: 1997+A11: 1997
IEC 950 : 1991+A1: 1992+A2: 1993+A3: 1995+A4: 1996
European Committee for Electrotechnical Standardization(CENELEC)
EUROPEAN STANDARD for Safety of Information Technology Equipment Including Electrical
Business Equipment.

7-2. EMC

- a) ANSI C63.4 'Methods of Measurement of Radio-Noise Emissions from Low-Voltage Electrical and Electrical Equipment in the Range of 9kHz to 40GHz. "American National Standards Institute(ANSI), 1992
- b) C.I.S.P.R 'Limits and Methods of Measurement of Radio Interface Characteristics of Information Technology Equipment." International Special Committee on Radio Interference
- c) EN 55022 'Limits and Methods of Measurement of Radio Interface Characteristics of Information Technology Equipment." European Committee for Electrotechnical Standardization (CENELEC), 1998

Product Specification

8. Packing

8-1. Designation of Lot Mark

a) Lot Mark

A	B	C	D	E	F	G	H	I	J	K	L	M
---	---	---	---	---	---	---	---	---	---	---	---	---

A,B,C : SIZE
 D : YEAR
 E : MONTH
 F,G : PANEL CODE
 H : ASSEMBLY CODE
 I,J,K,L,M : SERIAL NO.

Note:

1. YEAR

YEAR	97	98	99	2000	2001	2002	2003	2004	2005	2006	2007
Mark	7	8	9	0	1	2	3	4	5	6	7

2. MONTH

MONTH	Jan.	Feb.	Mar.	Apr.	May.	Jun.	Jul.	Aug.	Sep.	Oct.	Nov.	Dec.
Mark	1	2	3	4	5	6	7	8	9	10	11	12

3. Serial No.

Serial No.	1 ~ 99999	100000 ~
Mark	00001 ~ 99999	A0001 ~ A9999,....., Z9999

b) Location of Lot Mark

Serial NO. is printed on the label. The label is attached to the backside of the LCD module.
 This is subject to change without prior notice.

8-2. Packing Form

- a) Package quantity in one box : 8 pcs
- b) Box Size : 365mm×345mm×449mm

Product Specification

9. PRECAUTIONS

Please pay attention to the following when you use this TFT LCD module.

9-1. MOUNTING PRECAUTIONS

- (1) You must mount a module using holes arranged in four corners or four sides.
- (2) You should consider the mounting structure so that uneven force(ex. Twisted stress) is not applied to the module.
And the case on which a module is mounted should have sufficient strength so that external force is not transmitted directly to the module.
- (3) Please attach a transparent protective plate to the surface in order to protect the polarizer.
Transparent protective plate should have sufficient strength in order to the resist external force.
- (4) You should adopt radiation structure to satisfy the temperature specification.
- (5) Acetic acid type and chlorine type materials for the cover case are not describe because the former generates corrosive gas of attacking the polarizer at high temperature and the latter causes circuit break by electro-chemical reaction.
- (6) Do not touch, push or rub the exposed polarizers with glass, tweezers or anything harder than HB pencil lead. And please do not rub with dust clothes with chemical treatment.
Do not touch the surface of polarizer for bare hand or greasy cloth.(Some cosmetics are determined to the polarizer.)
- (7) When the surface becomes dusty, please wipe gently with absorbent cotton or other soft materials like chamois soaks with petroleum benzene. Normal-hexane is recommended for cleaning the adhesives used to attach front / rear polarizers. Do not use acetone, toluene and alcohol because they cause chemical damage to the polarizer.
- (8) Wipe off saliva or water drops as soon as possible. Their long time contact with polarizer causes deformations and color fading.
- (9) Do not open the case because inside circuits do not have sufficient strength.

9-2. OPERATING PRECAUTIONS

- (1) The spike noise causes the mis-operation of circuits. It should be lower than following voltage :
 $V=\pm 200\text{mV}$ (Over and under shoot voltage)
- (2) Response time depends on the temperature.(In lower temperature, it becomes longer.)
- (3) Brightness depends on the temperature. (In lower temperature, it becomes lower.)
And in lower temperature, response time(required time that brightness is stable after turned on) becomes longer.
- (4) Be careful for condensation at sudden temperature change. Condensation makes damage to polarizer or electrical contacted parts. And after fading condensation, smear or spot will occur.
- (5) When fixed patterns are displayed for a long time, remnant image is likely to occur.
- (6) Module has high frequency circuits. Sufficient suppression to the electromagnetic interference shall be done by system manufacturers. Grounding and shielding methods may be important to minimized the interference.

Product Specification

9-3. ELECTROSTATIC DISCHARGE CONTROL

Since a module is composed of electronic circuits, it is not strong to electrostatic discharge. Make certain that treatment persons are connected to ground through wrist band etc. And don't touch interface pin directly.

9-4. PRECAUTIONS FOR STRONG LIGHT EXPOSURE

Strong light exposure causes degradation of polarizer and color filter.

9-5. STORAGE

When storing modules as spares for a long time, the following precautions are necessary.

- (1) Store them in a dark place. Do not expose the module to sunlight or fluorescent light. Keep the temperature between 5°C and 35°C at normal humidity.
- (2) The polarizer surface should not come in contact with any other object.
It is recommended that they be stored in the container in which they were shipped.

9-6. HANDLING PRECAUTIONS FOR PROTECTION FILM

- (1) When the protection film is peeled off, static electricity is generated between the film and polarizer. This should be peeled off slowly and carefully by people who are electrically grounded and with well ion-blown equipment or in such a condition, etc.
- (2) The protection film is attached to the polarizer with a small amount of glue. If some stress is applied to rub the protection film against the polarizer during the time you peel off the film, the glue is apt to remain on the polarizer.
Please carefully peel off the protection film without rubbing it against the polarizer.
- (3) When the module with protection film attached is stored for a long time, sometimes there remains a very small amount of glue still on the polarizer after the protection film is peeled off.
- (4) You can remove the glue easily. When the glue remains on the polarizer surface or its vestige is recognized, please wipe them off with absorbent cotton waste or other soft material like chamois soaked with normal-hexane.