



深圳市拓普微科技开发有限公司

SHENZHEN TOPWAY TECHNOLOGY CO., LTD.

# LM160160PCW

## LCD Module User Manual

Prepared by:  <b>Chen Rili</b>  Date: 2018-03-15	Checked by:    Date:	Approved by:    Date:
--	----------------------------------	-----------------------------------

Rev.	Descriptions	Release Date
0.1	Preliminary release	2018-03-15

---

**Table of Content**

<b>1. Basic Specifications</b> .....	<b>3</b>
<b>1.1 Display Specifications</b> .....	<b>3</b>
<b>1.2 Mechanical Specifications</b> .....	<b>3</b>
<b>1.3 Block Diagram</b> .....	<b>3</b>
<b>1.4 Terminal Functions</b> .....	<b>4</b>
<b>2. Absolute Maximum Ratings</b> .....	<b>5</b>
<b>3. Electrical Characteristics</b> .....	<b>5</b>
<b>3.1 DC Characteristics</b> .....	<b>5</b>
<b>3.2 LED Backlight Circuit Characteristics</b> .....	<b>5</b>
<b>3.3 AC Characteristics</b> .....	<b>6</b>
<b>4. Function specifications</b> .....	<b>7</b>
<b>4.1 Adjusting the Display Contrast</b> .....	<b>7</b>
<b>4.2 Resetting the LCD module</b> .....	<b>7</b>
<b>4.3 Display Commands</b> .....	<b>8</b>
<b>5. Design and Handling Precaution</b> .....	<b>10</b>

## 1. Basic Specifications

### 1.1 Display Specifications

- 1) LCD Display Mode : FSTN, Positive, Transflective
- 2) Display Color : Display Data = "1" : Dark Gray(\*1)  
: Display Data = "0" : Light Gray (\*2)
- 3) Viewing Angle : 6H
- 4) Driving Method : 1/160 duty, 1/12 bias
- 5) Backlight : White LED backlight

Note:

\*1. Color tone may slightly change by Temperature and Driving Condition.

\*2. The Color is defined as the inactive / background color

\*3. Fine Contrast adjustment function is necessary in the application design for optimal display result

### 1.2 Mechanical Specifications

- 1) Outline Dimension : 83.8 x 76.5 x 9.6MAX (exclude FFC terminal)  
(See attached Outline Drawing for details)

### 1.3 Block Diagram

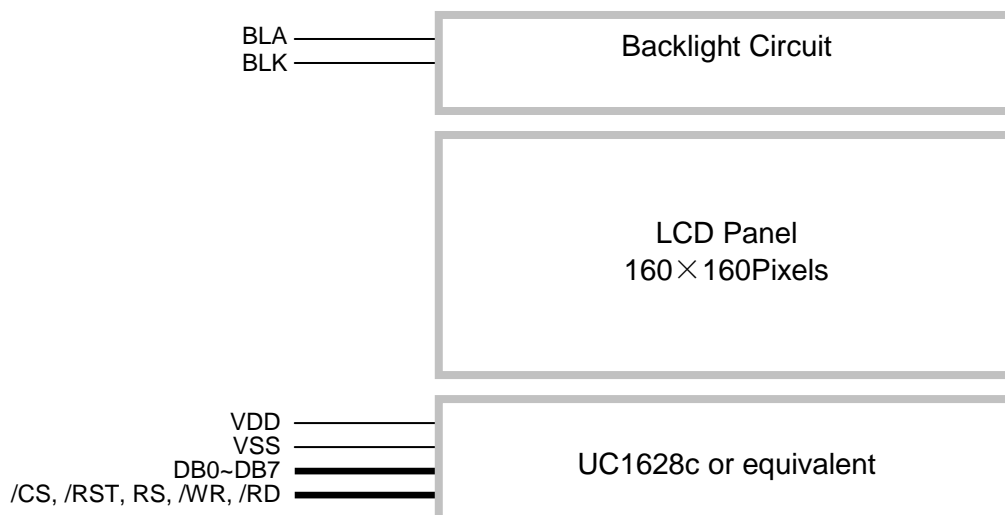

## 1.4 Terminal Functions

Pin No.	PIN Name	I/O	Descriptions
1	VSS	P	Negative power supply,0V
2	RS	I	Register Select RS = H, Transferring the Display Data RS = L, Transferring the Control Data
3	/WR	I	/WR=L→H, /RD=H; Data or Instruction latch into the LCD module
4	/RD	I	/WR=H, /RD=L; Data or Status read form the LCD module
5	/CS	I	Chip Select /CS=L, enable access to the LCD module /CS=H, disable access to the LCD module
6	/RST	I	Reset signal /RST = L, Initialization is executed /RST = H, Normal running.
7	VDD	P	Positive power supply
8	DB0	I/O	8-bit Data bus; Three state I/O terminal for display data or instruction data when /CS=H, DB0~DB7=High Impedance
:	:		
15	DB7		
16	BLK	P	Negative power for LED backlight
17	NC	-	No connection
18	BLA	P	Positive power for LED backlight

## 2. Absolute Maximum Ratings

Items	Symbol	Min.	Max.	Unit	Condition
Supply Voltage	$V_{DD}$	-0.3	+4.0	V	$V_{SS} = 0V$
Input Voltage	$V_{IN}$	-0.3	+4.0	V	$V_{SS} = 0V$
Operating Temperature	$T_{OP}$	-40	+70	°C	No Condensation
Storage Temperature	$T_{ST}$	-40	+80	°C	No Condensation

Cautions:

Any Stresses exceeding the Absolute Maximum Ratings may cause substantial damage to the device. Functional operation of this device at other conditions beyond those listed in the specification is not implied and prolonged exposure to extreme conditions may affect device reliability.

## 3. Electrical Characteristics

### 3.1 DC Characteristics

$V_{DD}=3.3V, V_{SS}=0V, T_{OP}=25^{\circ}C$

Items	Symbol	MIN.	TYP.	MAX.	Unit	Condition / Application Pin
Operating Voltage	$V_{DD}$	2.7	3.3	3.6	V	VDD
Input High Voltage	$V_{IH}$	$0.8 \times V_{DD}$	-	$V_{DD}$	V	/RST, /CS, RS,
Input Low Voltage	$V_{IL}$	$V_{SS}$	-	$0.2 \times V_{DD}$	V	DB0~DB7, /RD, /WR
Operating Current	$I_{DD}$	-	1.06	5.6	mA	VDD

### 3.2 LED Backlight Circuit Characteristics

$BLA=3.3V, BLK=0V, T_{OP}=25^{\circ}C$

Items	Symbol	MIN.	TYP.	MAX.	Unit	Applicable Pin
Forward Voltage	BLA	-	3.3	-	V	BLA
Forward Current	$I_{BLA}$	-	68	80	mA	BLA

Cautions:

Exceeding the recommended driving current could cause substantial damage to the backlight and shorten its lifetime.

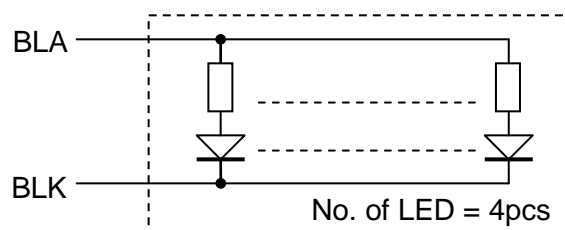

### 3.3 AC Characteristics

#### 3.3.1 8080 Mode System Bus Timing

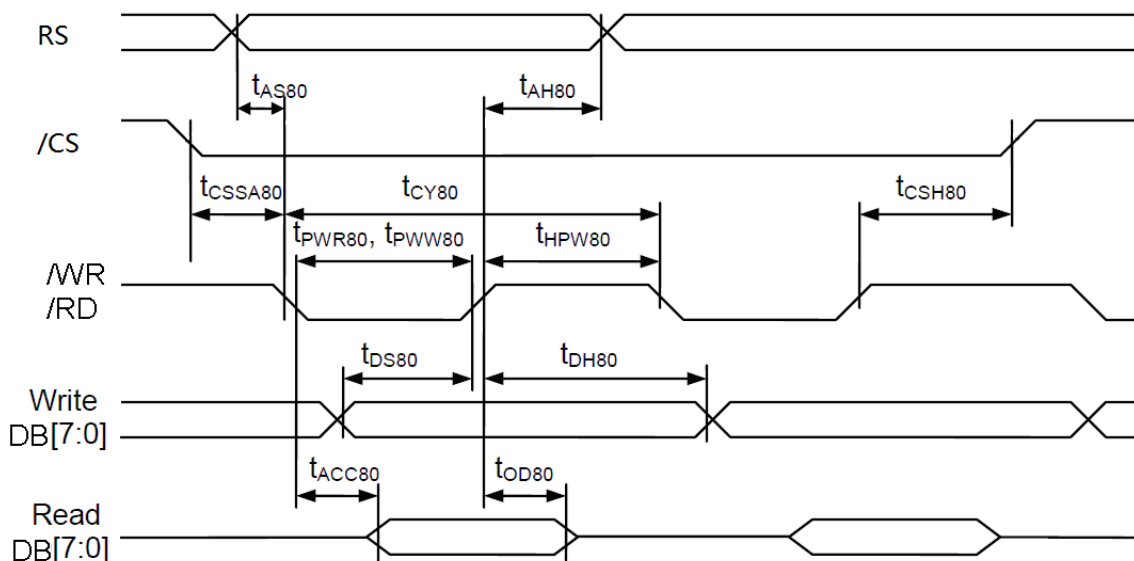

$V_{DD}=3.3V$ ,  $V_{SS}=0V$ ,  $T_{OP}=25^{\circ}C$

Item	Symbol	MIN.	MAX.	Unit
Address setup time (RS)	tas80	20	-	ns
Address hold time (RS)	tah80	26	-	ns
System cycle time (8bit)	tcy80	560	-	ns
Read pulse width	tpwr80	260	-	ns
Write pulse width	tpww80	163	-	ns
High pulse width (read)	thpw80	260	-	ns
High pulse width (write)	thpw80	163	-	ns
Data setup time	tds80	59	-	ns
Data hold time	tdh80	13	-	ns
Data access time	tacc80	-	260	ns
Data output disable time	tod80	70	-	ns
Chip select setup time	tcssa80	7	-	ns
Chip select hold time	tcs80	7	-	ns

Note:

- \*1. Input signal rise/fall time should be less than 15ns .
- \*2. CL=100pF
- \*3.All timing is using 20% and 80% of VDD as the reference.

#### 3.3.2 Reset Timing

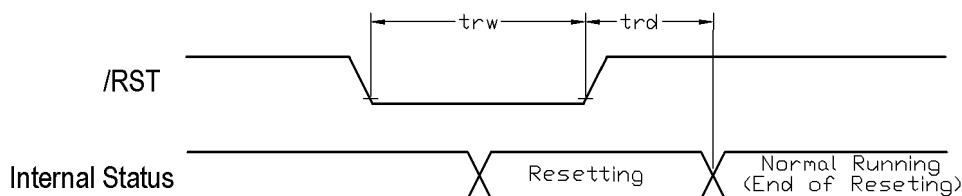

$V_{DD}=3.3V$ ,  $V_{SS}=0V$ ,  $T_{OP}=25^{\circ}C$

Item	Symbol	MIN.	TYP.	MAX.	Unit
Reset LOW pulse width	trw	4	-	-	us
Internal Resetting time	trd	150	-	-	ms

Note:

- \*1.All timing is using 20% and 80% of VDD as the reference.

## 4. Function specifications

### 4.1 Adjusting the Display Contrast

This LCD module equipped with latest digital contrast adjustment function. Its display contrast could be adjusted by MCU command.

(Please see the command tables for details)

It is recommended to provide a contrast adjustment interface for end-user, where the best display result could meet the individual preference in mass production.

### 4.2 Resetting the LCD module

The LCD module should be initialized by using /RST terminal.

While turning on the VDD and VSS power supply, maintain /RST terminal at LOW level. After the power supply stabilized, release the reset terminal (/RST=HIGH)\

### 4.3 Display Commands

The LCD module contains register, which control the operation. These register can be modified by commands. The following table is a summary of the control registers, their meaning and their default value.

#### 4.3.1 Command Table

The following is the list of host command supported.

**C/D**: 0: Control, 1: Data    **W/R**: 0: Write Cycle, 1: Read Cycle    **D7-D0**: #: Useful Data bits --: Don't Care

#	Command	C/D	W/R	D7	D6	D5	D4	D3	D2	D1	D0	Action	Default
1.	Write Data Byte (double-byte command)	0	0	0	0	0	0	0	0	0	1	Write 1 byte	N/A
		1	0	#	#	#	#	#	#	#	#		
2.	Read Data Byte (double-byte command)	0	0	0	0	0	0	0	0	1	0	Read 1 byte	N/A
		1	1	#	#	#	#	#	#	#	#		
3.	Get Status (triple-byte command)	0	0	0	0	0	0	0	0	1	1	Get Status	N/A
		1	1	POR	MX	MY	PID	DE	OD	OE	OP		
		1	1	Ver[1:0]		PMO[5:0]							
4.	Set Column Address (double-byte command)	0	0	0	0	0	0	0	1	0	0	Set CA[7:0]	00H
		1	0	#	#	#	#	#	#	#	#		
5.	Set Temp. vs. Vop Control	0	0	0	0	0	1	0	0	0	#	Set TC[3]	0b
6.	Set Temp. vs. FR Control	0	0	0	0	0	1	0	0	1	#	Set TC[4]	0b
7.	Set Temp. Sensor Control	0	0	0	0	0	1	0	1	0	#	Set TC[5]	0b
8.	Set FR at Different temperature (triple-byte command)	0	0	0	0	0	1	0	1	1	0	Set TP[3:0] Set FR[4:0]	N/A
		1	0	0	0	0	0	#	#	#	#		
		1	0	0	0	0	#	#	#	#	#		
9.	Set FR (triple-byte command)	0	0	0	0	0	1	0	1	1	0	Set FR[4:0]	01101b
		1	0	0	0	0	0	0	0	0	0		
		1	0	0	0	0	#	#	#	#	#		
10.	Set Temperature Point (triple-byte command)	0	0	0	0	0	1	0	1	1	1	Set TP[3:0] Set ST[7:0]	N/A
		1	0	0	0	0	0	#	#	#	#		
		1	0	#	#	#	#	#	#	#	#		
11.	Set Temp. Compensagion	0	0	0	0	1	0	0	#	#	#	Set TC[2:0]	100b
12.	Set Pump Control	0	0	0	0	1	0	1	1	0	#	Set PC	1b
13.	Set Adv. Program Control (double-byte command)	0	0	0	0	1	1	0	0	R	R	R = 0, 1, 2 or 3	N/A
		1	0	#	#	#	#	#	#	#	#	Set APC[R][7:0]	
14.	Set Scroll Line	0	0	0	1	0	0	0	0	0	0	Set SL[7:0]	00H
		1	0	#	#	#	#	#	#	#	#		
15.	Set Page Address	0	0	0	1	1	0	0	0	0	0	Set PA[4:0]	00H
		1	0	0	0	0	#	#	#	#	#		
16.	Set PM at Different temperature (triple-byte command)	0	0	1	0	0	0	0	0	0	1	Set TP[3:0] Set PM[7:0]	N/A
		1	0	0	0	0	0	#	#	#	#		
		1	0	#	#	#	#	#	#	#	#		
17.	Set PM (triple-byte command)	0	0	1	0	0	0	0	0	0	1	Set PM[7:0]	54H
		1	0	0	0	0	0	0	0	0	0		
		1	0	#	#	#	#	#	#	#	#		



#	Command	C/D	W/R	D7	D6	D5	D4	D3	D2	D1	D0	Action	Default
18.	Set Partial Display Control	0	0	1	0	0	0	0	1	0	#	Set LC[3]	0b: Disable
19.	Set COM Scan Function	0	0	1	0	0	0	0	1	1	#	Set CSF	0b: Interface
20.	Set RAM Address Control	0	0	1	0	0	0	1	#	#	#	Set AC[2:0]	001b
21.	Set All-Pixel-ON	0	0	1	0	1	0	0	1	0	#	Set DC[1]	0b
22.	Set Inverse Display	0	0	1	0	1	0	0	1	1	#	Set DC[0]	0b
23.	Set LCD Mapping Control	0	0	1	1	0	0	0	#	#	#	Set LC[2:0]	001b
24.	Set N-Line Inversion (double-byte command)	0	0	1	1	0	0	1	0	0	0	Set NV[6:0]	00H
		1	0	0	#	#	#	#	#	#	#		
25.	Set Display Enable unlock Set Display Enable	0	0	1	1	0	0	1	0	0	1	Set DC[2]	0b
		1	0	1	0	1	0	1	1	0	#		
26.	NOP	0	0	1	1	1	0	0	0	1	1	No operation	N/A
27.	Set Test Control (double-byte command)	0	0	1	1	1	0	0	1	TT		For testing only.	N/A
		1	0	#	#	#	#	#	#	#	#	Do not use.	
28.	Set LCD Bias Ratio	0	0	1	1	1	0	1	#	#	#	Set BR[2:0]	011b
29.	Reset Cursor update mode	0	0	1	1	1	1	0	1	1	0	AC[3]=0, CA=CR	N/A
30.	Set Cursor update mode	0	0	1	1	1	1	0	1	1	1	AC[3]=1, CR=CA	N/A
31.	Set COM End (double-byte command)	0	0	1	1	1	1	0	0	0	1	Set CEN[7:0]	161
		1	0	#	#	#	#	#	#	#	#		
32.	Set Partial Display Start (double-byte command)	0	0	1	1	1	1	0	0	1	0	Set DST[7:0]	0
		1	0	#	#	#	#	#	#	#	#		
33.	Set Partial Display End (double-byte command)	0	0	1	1	1	1	0	0	1	1	Set DEN[7:0]	161
		1	0	#	#	#	#	#	#	#	#		
34.	Set OTP Operation Control (double-byte command)	0	0	1	0	1	1	1	0	0	0	Set OTPC[4:0]	00H
		1	0	0	0	0	#	#	#	#	#		
35.	Set OTP Write Address (double-byte command)	0	0	1	0	1	1	1	0	0	1	Set OTPA[5:0]	00H
		1	0	0	0	#	#	#	#	#	#		

**Warning:** Any bit patterns other than the commands listed above may result in undefined behavior.

Note:

Please refer to UC1628c data sheet for details

R/W=0 means it is a write function, R/W=1 means it is a read function

RS=0 means it is a control data, RS=1 means it is a display data

## 5. Design and Handling Precaution

1. The LCD panel is made by glass. Any mechanical shock (eg. dropping from high place) will damage the LCD module.
2. Do not add excessive force on the surface of the display, which may cause the Display color change abnormally.
3. The polarizer on the LCD is easily get scratched. If possible, do not remove the LCD protective film until the last step of installation.
4. Never attempt to disassemble or rework the LCD module.
5. Only Clean the LCD with Isopropyl Alcohol or Ethyl Alcohol. Other solvents (eg. water) may damage the LCD.
6. When mounting the LCD module, make sure that it is free from twisting, warping and distortion.
7. Ensure to provide enough space (with cushion) between case and LCD panel to prevent external force adding on it, or it may cause damage to the LCD or degrade the display result.
8. Only hold the LCD module by its side. Never hold LCD module by add force on the heat seal or TAB.
9. Never add force to component of the LCD module. It may cause invisible damage or degrade of the reliability.
10. LCD module could be easily damaged by static electricity. Be careful to maintain an optimum anti-static work environment to protect the LCD module.
11. When peeling off the protective film from LCD, static charge may cause abnormal display pattern. It is normal and will resume to normal in a short while.
12. Take care and prevent get hurt by the LCD panel sharp edge.
13. Never operate the LCD module exceed the absolute maximum ratings.
14. Keep the signal line as short as possible to prevent noisy signal applying to LCD module.
15. Never apply signal to the LCD module without power supply.
16. IC chip (eg. TAB or COG) is sensitive to the light. Strong lighting environment could possibly cause malfunction. Light sealing structure casing is recommend.
17. LCD module reliability may be reduced by temperature shock.
18. When storing the LCD module, avoid exposure to the direct sunlight, high humidity, high temperature or low temperature. They may damage or degrade the LCD module