

Product Specification

# SPECIFICATION FOR APPROVAL

- ( ) Preliminary Specification
- (●) Final Specification

|       |                    |
|-------|--------------------|
| Title | 17.1" WXGA TFT LCD |
|-------|--------------------|



|       |      |
|-------|------|
| BUYER | DELL |
| MODEL | -    |

|          |                          |
|----------|--------------------------|
| SUPPLIER | LG.Philips LCD Co., Ltd. |
| *MODEL   | LM171WX3                 |
| SUFFIX   | TLB1                     |

\*When you obtain standard approval, please use the above model name without suffix

| APPROVED BY | SIGNATURE<br>DATE |
|-------------|-------------------|
| /           | _____             |
| /           | _____             |
| /           | _____             |

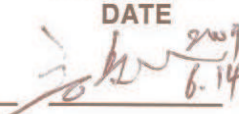
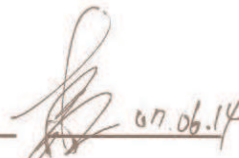
Please return 1 copy for your confirmation with your signature and comments.

|                      |                                                                                                   |
|----------------------|---------------------------------------------------------------------------------------------------|
| APPROVED BY          | SIGNATURE<br>DATE                                                                                 |
| S.G.Hong / G.Manager | <br>6.14     |
| REVIEWED BY          |                                                                                                   |
| D.I.Chung / Manager  | <br>07.06.14 |
| PREPARED BY          |                                                                                                   |
| K.H.Lee / Engineer   | <br>07.06.14 |

**MNT Products Engineering Dept.**  
**LG. Philips LCD Co., Ltd**

Product Specification

Contents

| No  | ITEM                                 | Page |
|-----|--------------------------------------|------|
|     | COVER                                | 1    |
|     | CONTENTS                             | 2    |
|     | RECORD OF REVISIONS                  | 3    |
| 1   | GENERAL DESCRIPTION                  | 4    |
| 2   | ABSOLUTE MAXIMUM RATINGS             | 5    |
| 3   | ELECTRICAL SPECIFICATIONS            | 6    |
| 3-1 | ELECTRICAL CHARACTREISTICS           | 6    |
| 3-2 | INTERFACE CONNECTIONS                | 9    |
| 3-3 | SIGNAL TIMING SPECIFICATIONS         | 11   |
| 3-4 | SIGNAL TIMING WAVEFORMS              | 12   |
| 3-5 | COLOR INPUT DATA REFERNECE           | 13   |
| 3-6 | POWER SEQUENCE                       | 14   |
| 3-7 | V <sub>LCD</sub> POWER DIP CONDITION | 15   |
| 4   | OPTICAL SFECIFICATIONS               | 16   |
| 5   | MECHANICAL CHARACTERISTICS           | 20   |
| 6   | RELIABILITY                          | 23   |
| 7   | INTERNATIONAL STANDARDS              | 24   |
| 7-1 | SAFETY                               | 24   |
| 7-2 | EMC                                  | 24   |
| 8   | PACKING                              | 25   |
| 8-1 | DESIGNATION OF LOT MARK              | 25   |
| 8-2 | PACKING FORM                         | 25   |
| 9   | PRECAUTIONS                          | 26   |



Product Specification

### 1. General Description

LM171WX3-TLB1 is a Color Active Matrix Liquid Crystal Display with an integral Cold Cathode Fluorescent Lamp(CCFL) backlight system. The matrix employs a-Si Thin Film Transistor as the active element. It is a transmissive type display operating in the normally white mode. It has a 17.1 inch diagonally measured active display area with WXGA+ resolution (1440 vertical by 900 horizontal pixel array) Each pixel is divided into Red, Green and Blue sub-pixels or dots which are arranged in vertical stripes. Gray scale or the brightness of the sub-pixel color is determined with a 8-bit gray scale signal for each dot, thus, presenting a palette of more than 16,7M colors with Advanced-FRC(Frame Rate Control). It has been designed to apply the interface method that enables low power, high speed, low EMI. FPD Link or compatible must be used as a LVDS(Low Voltage Differential Signaling) chip. It is intended to support applications where thin thickness, wide viewing angle, low power are critical factors and graphic displays are important. In combination with the vertical arrangement of the sub-pixels, the LM171WX3-TLB1 characteristics provide an excellent flat panel display for office automation products such as monitors.

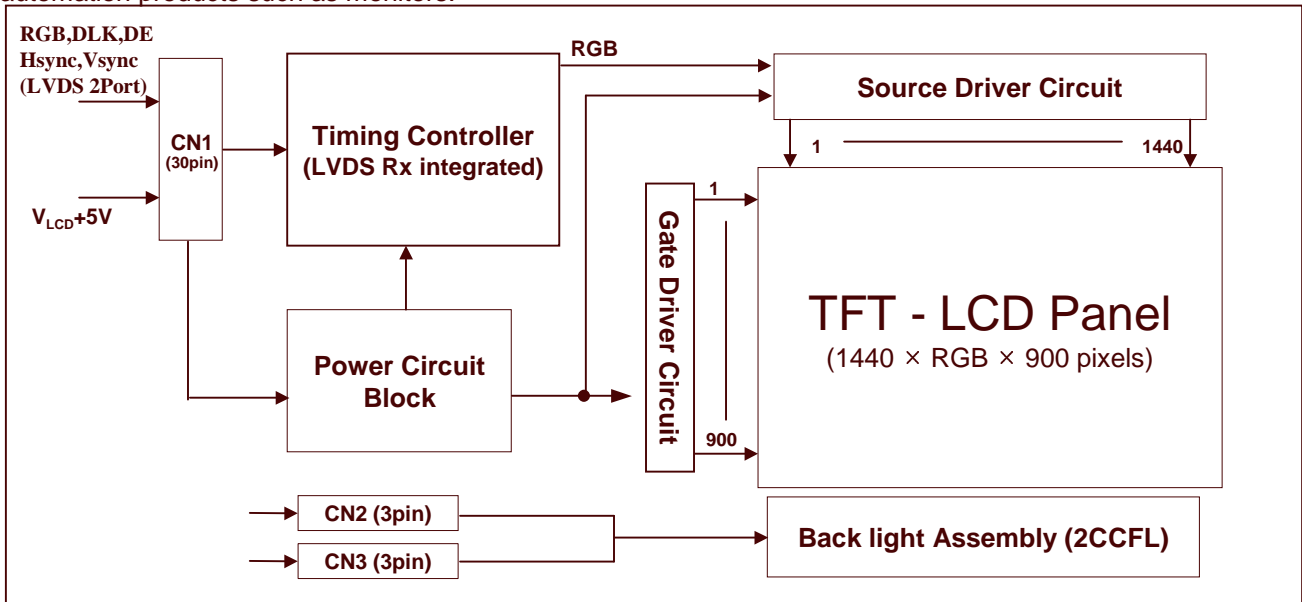

### General Features

|                        |                                                                                  |
|------------------------|----------------------------------------------------------------------------------|
| Active Screen Size     | 17.1 inches(43.3019cm) diagonal (Aspect ratio 16:10)                             |
| Outline Dimension      | 389.2(H)x254.5(V)x11.5(D) mm (Typ.)                                              |
| Pixel Pitch            | 0.255mm x 0.255mm                                                                |
| Pixel Format           | 1440 horiz. By 900 vert. Pixels RGB strip arrangement                            |
| Color Depth            | 16.7M colors                                                                     |
| Luminance, White       | 250 cd/m <sup>2</sup> (Center 1 points Typ.)                                     |
| Viewing Angle (CR>10)  | R/L 160(Typ.), U/D 160(Typ)                                                      |
| Power Consumption      | Total 12.92 Watt(Typ.) (2.6 Watt@V <sub>LCD</sub> , 10.32 Watt@250cd/[Lamp=8mA]) |
| Weight                 | 1360 g (Typ.)                                                                    |
| Display Operating Mode | Transmissive mode, normally white                                                |
| Surface Treatment      | Glare treatment of the front polarizer                                           |

Product Specification

## 2. Absolute Maximum Ratings

The following are maximum values which, if exceeded, may cause faulty operation or damage to the unit.

**Table 1. ABSOLUTE MAXIMUM RATINGS**

| Parameter                  | Symbol | Values |      | Units | Notes        |
|----------------------------|--------|--------|------|-------|--------------|
|                            |        | Min    | Max  |       |              |
| Power Input Voltage        | VLCD   | -0.3   | +4.0 | Vdc   | at 25 ± 2 °C |
| Operating Temperature      | TOP    | 0      | 50   | °C    | 1            |
| Storage Temperature        | TST    | -20    | 60   | °C    | 1            |
| Operating Ambient Humidity | HOP    | 10     | 90   | %RH   | 1            |
| Storage Humidity           | HST    | 10     | 90   | %RH   | 1            |

Note : 1. Temperature and relative humidity range are shown in the figure below.  
Wet bulb temperature should be 39 °C Max, and no condensation of water.

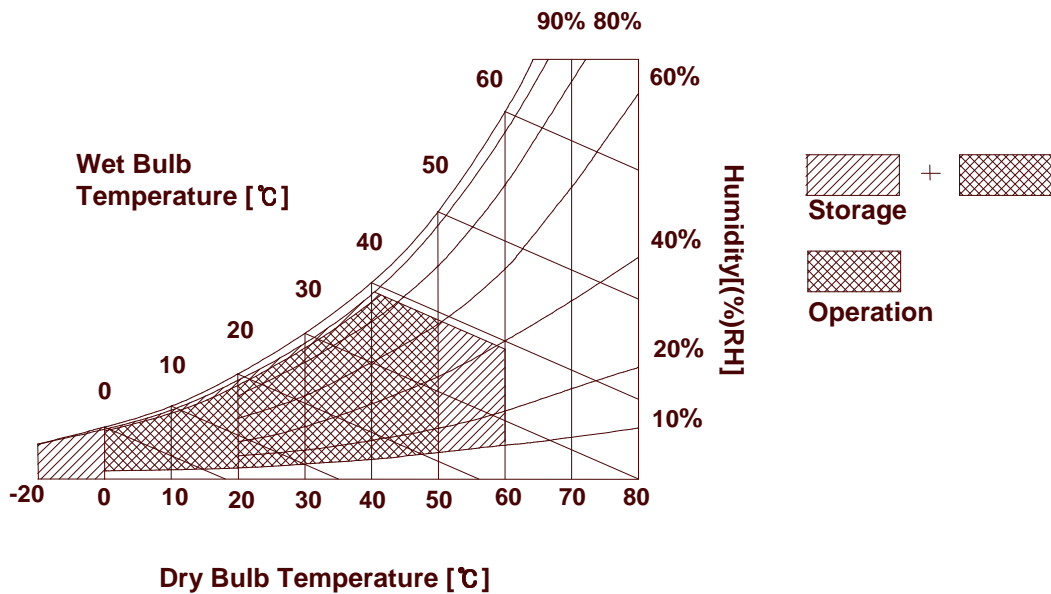

Product Specification

### 3. Electrical Specifications

#### 3-1. Electrical Characteristics

It requires two power inputs. One is employed to power the LCD electronics and to drive the TFT array and liquid crystal. The second input power for the CCFL, is typically generated by an inverter. The inverter is an external unit to the LCDs.

**Table 2\_1. ELECTRICAL CHARACTERISTICS**

| Parameter                  | Symbol            | Values |     |     | Unit | Notes |
|----------------------------|-------------------|--------|-----|-----|------|-------|
|                            |                   | Min    | Typ | Max |      |       |
| MODULE :                   |                   |        |     |     |      |       |
| Power Supply Input Voltage | V <sub>LCD</sub>  | 4.5    | 5.0 | 5.5 | Vdc  |       |
| Power Supply Input Current | I <sub>LCD</sub>  | -      | 520 | 600 | mA   | 1     |
|                            |                   | -      | 590 | 680 | mA   | 2     |
| Power Consumption          | P <sub>LCD</sub>  | -      | 2.6 | 3.3 | Watt | 1     |
| Inrush current             | I <sub>RUSH</sub> | -      | -   | 3   | A    | 3     |

Note :

1. The specified current and power consumption are under the V<sub>LCD</sub>=5V, 25 ± 2°C, f<sub>v</sub>=60Hz condition whereas mosaic pattern(8 x 6) is displayed and f<sub>v</sub> is the frame frequency.
2. The current is specified at the maximum current pattern.
3. The duration of rush current is about 2ms and rising time of power Input is 500us ± 20%.

White : 63Gray  
Black : 0Gray

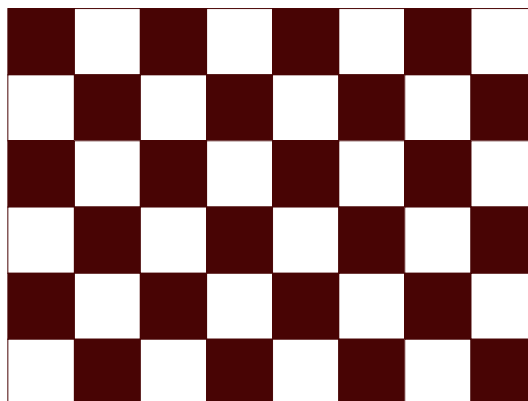

Mosaic Pattern(8 x 6)

Product Specification

**Table 2\_2. ELECTRICAL CHARACTERISTICS**

| Parameter                    | Symbol          | Values     |          |            | Unit              | Notes |
|------------------------------|-----------------|------------|----------|------------|-------------------|-------|
|                              |                 | Min        | Typ      | Max        |                   |       |
| LAMP :                       |                 |            |          |            |                   |       |
| Operating Voltage            | V <sub>BL</sub> | 615(9.0mA) | 645(8mA) | 815(2.5mA) | V <sub>RMS</sub>  | 1, 2  |
| Operating Current            | I <sub>BL</sub> | 2.5        | 8.0      | 9.0        | mA <sub>RMS</sub> | 1     |
| Established Starting Voltage | V <sub>S</sub>  |            |          |            |                   | 1, 3  |
|                              | at 25 °C        |            |          | 1000       | V <sub>RMS</sub>  |       |
|                              | at 0 °C         |            |          | 1250       | V <sub>RMS</sub>  |       |
| Operating Frequency          | f <sub>BL</sub> | 40         | 60       | 80         | kHz               | 4     |
| Discharge Stabilization Time | T <sub>S</sub>  |            |          | 3          | Min               | 1, 5  |
| Power Consumption            | P <sub>BL</sub> |            | 10.32    | 11.35      | Watt              | 6     |
| Life Time                    |                 | 40,000     |          |            | Hrs               | 1, 7  |

Note : The design of the inverter must have specifications for the lamp in LCD Assembly.

The performance of the Lamp in LCM, for example life time or brightness, is extremely influenced by the characteristics of the DC-AC inverter. So all the parameters of an inverter should be carefully designed so as not to produce too much leakage current from high-voltage output of the inverter.

When you design or order the inverter, please make sure unwanted lighting caused by the mismatch of the lamp and the inverter (no lighting, flicker, etc) never occurs. When you confirm it, the LCD-Assembly should be operated in the same condition as installed in you instrument.

※ Do not attach a conducting tape to lamp connecting wire.

If the lamp wire attach to a conducting tape, TFT-LCD Module has a low luminance and the inverter has abnormal action. Because leakage current is occurred between lamp wire and conducting tape.

1. Specified values are for a single lamp.
2. Operating voltage is measured at 25 ± 2°C. The variance of the voltage is ± 10%.
3. The voltage above V<sub>S</sub> should be applied to the lamps for more than 1 second for start-up.  
(Inverter open voltage must be more than lamp starting voltage.)  
Otherwise, the lamps may not be turned on. The used lamp current is the lamp typical current.
4. Lamp frequency may produce interface with horizontal synchronous frequency and as a result this may cause beat on the display. Therefore lamp frequency shall be as away possible from the horizontal synchronous frequency and from its harmonics in order to prevent interference.
5. Let's define the brightness of the lamp after being lighted for 5 minutes as 100%.  
T<sub>S</sub> is the time required for the brightness of the center of the lamp to be not less than 95%.
6. The lamp power consumption shown above does not include loss of external inverter.  
The used lamp current is the lamp typical current. (P<sub>BL</sub> = V<sub>BL</sub> × I<sub>BL</sub> × )
7. The life is determined as the time at which brightness of the lamp is 50% compared to that of initial value at the typical lamp current on condition of continuous operating at 25 ± 2°C.

Product Specification

8. The output of the inverter must have symmetrical(negative and positive) voltage waveform and symmetrical current waveform (Unsymmetrical ratio is less than 10%). Please do not use the inverter which has unsymmetrical voltage and unsymmetrical current and spike wave.

Requirements for a system inverter design, which is intended to have a better display performance, a better power efficiency and a more reliable lamp, are following.

It shall help increase the lamp lifetime and reduce leakage current.

a. The asymmetry rate of the inverter waveform should be less than 10%.

b. The distortion rate of the waveform should be within  $\sqrt{2} \pm 10\%$ .

\* Inverter output waveform had better be more similar to ideal sine wave.

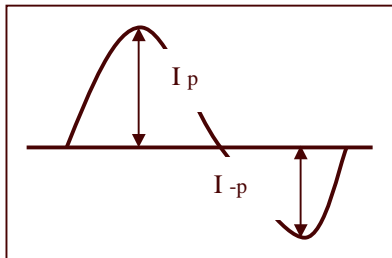

\* Asymmetry rate:

$$\frac{|I_p - I_{-p}|}{I_{rms}} \times 100\%$$

\* Distortion rate

$$I_p \text{ (or } I_{-p}) / I_{rms}$$

9. The inverter which is combined with this LCM, is highly recommended to connect coupling(ballast) condenser at the high voltage output side. When you use the inverter which has not coupling(ballast) condenser, it may cause abnormal lamp lighting because of biased mercury as time goes.

10. In case of edgy type back light with over 4 parallel lamps, input current and voltage wave form should be synchronized



Product Specification

### 3-2. Interface Connections

- LCD Connector(CN1) : AL230F-ALG1D-P (P-Two) and IS100-L30R-C23(UJU)
- Mating Connector : FI-X30H and FI-X30HL (Manufactured by JAE) or Equivalent

**Table 3. MODULE CONNECTOR(CN1) PIN CONFIGURATION**

| Pin No | Symbol           | Description                               |
|--------|------------------|-------------------------------------------|
| 1      | RXO0-            | Minus signal of 1st channel 0 (LVDS)      |
| 2      | RXO0+            | Plus signal of 1st channel 0 (LVDS)       |
| 3      | RXO1-            | Minus signal of 1'st channel 1 (LVDS)     |
| 4      | RXO1+            | Plus signal of 1'st channel 1 (LVDS)      |
| 5      | RXO2-            | Minus signal of 1'st channel 2 (LVDS)     |
| 6      | RXO2+            | Plus signal of 1'st channel 2 (LVDS)      |
| 7      | GND              | Ground                                    |
| 8      | RXOC-            | Minus signal of 1'st clock channel (LVDS) |
| 9      | RXOC+            | Plus signal of 1'st clock channel (LVDS)  |
| 10     | RXO3-            | Minus signal of 1'st channel 3 (LVDS)     |
| 11     | RXO3+            | Plus signal of 1'st channel 3 (LVDS)      |
| 12     | RXE0-            | Minus signal of 2'nd channel 0 (LVDS)     |
| 13     | RXE0+            | Plus signal of 2'nd channel 0 (LVDS)      |
| 14     | GND              | Ground                                    |
| 15     | RXE1-            | Minus signal of 2'nd channel 1 (LVDS)     |
| 16     | RXE1+            | Plus signal of 2'nd channel 1 (LVDS)      |
| 17     | GND              | Ground                                    |
| 18     | RXE2-            | Minus signal of 2'nd channel 2 (LVDS)     |
| 19     | RXE2+            | Plus signal of 2'nd channel 2 (LVDS)      |
| 20     | RXEC-            | Minus signal of 2'nd clock channel (LVDS) |
| 21     | RXEC+            | Plus signal of 2'nd clock channel (LVDS)  |
| 22     | RXE3-            | Minus signal of 2'nd channel 3 (LVDS)     |
| 23     | RXE3+            | Plus signal of 2'nd channel 3 (LVDS)      |
| 24     | GND              | Ground                                    |
| 25     | NC               | No Connection                             |
| 26     | NC               | No Connection                             |
| 27     | PWM_out          | Reference signal for inverter control     |
| 28     | V <sub>LCD</sub> | Power Supply +5.0V                        |
| 29     | V <sub>LCD</sub> | Power Supply +5.0V                        |
| 30     | V <sub>LCD</sub> | Power Supply +5.0V                        |

- Note:
1. All GND(ground) pins should be connected together and to Vss which should also be connected to the LCD's metal frame.
  2. All V<sub>LCD</sub> (power input) pins should be connected together.
  3. All NC pins should be separated from other signal or power.

Product Specification

User Connector Diagram

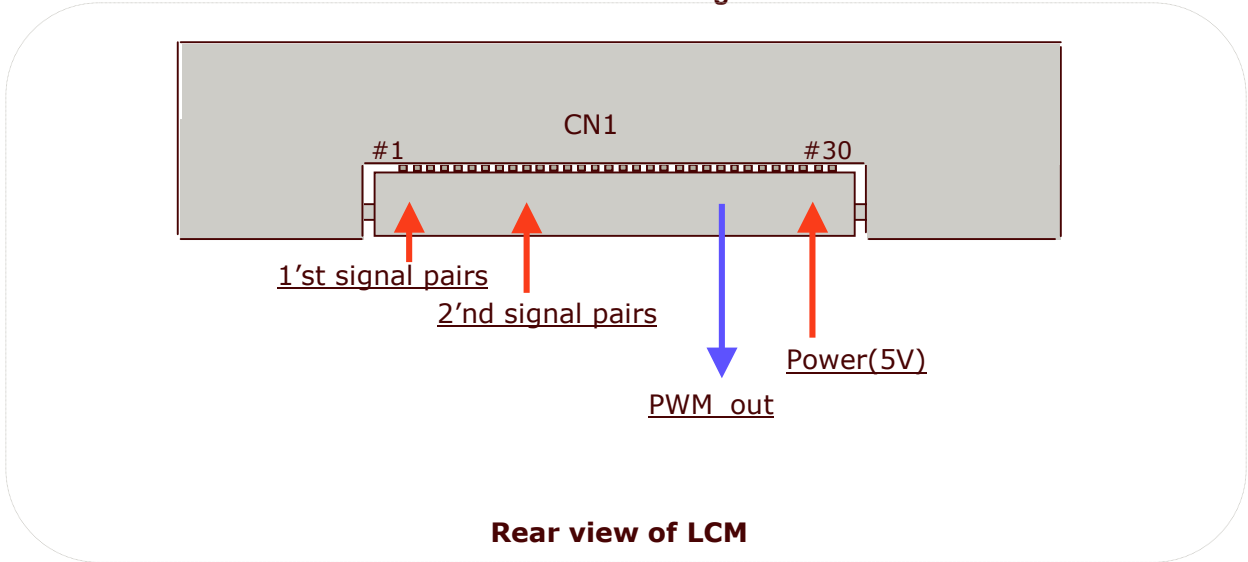
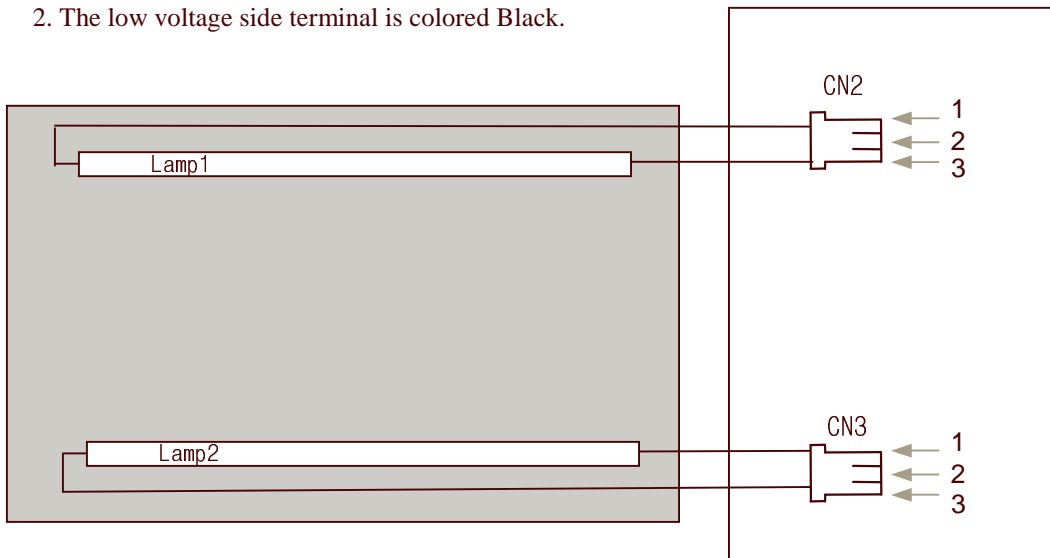

Table 4. BACKLIGHT CONNECTOR PIN CONFIGURATION (CN2,CN3)

| Pin | Symbol | Description                  | Notes                            |
|-----|--------|------------------------------|----------------------------------|
| 1   | HV     | Power supply for lamp (high) | LCD : 20015HS-03LB(GRY) (YEONHO) |
| 2   | NC     | No connect                   |                                  |
| 3   | LV     | Power supply for lamp (Low)  |                                  |

Notes : 1. The high voltage side terminal is colored Gray.  
2. The low voltage side terminal is colored Black.



Product Specification

### 3-3. Signal Timing Specifications

This is the signal timing required at the input of the LVDS Transmitter. All of the interface signal timing should be satisfied with the following specifications for its proper operation.

**Table 5. Timing Table**

| ITEM                | Symbol                 |                | Min    | Typ   | Max    | Unit | Note |
|---------------------|------------------------|----------------|--------|-------|--------|------|------|
| DCLK                | Period                 | tCLK           | 22.53  | 18.78 | 14.63  | ns   |      |
|                     | Frequency              | fCLK           | 43.375 | 53.25 | 68.375 | MHz  |      |
| Hsync               | Period                 | tHP            | 936    | 952   | 968    | tCLK |      |
|                     | Width                  | tWH            | 72     | 76    | 76     | tCLK |      |
| Vsync               | Period                 | tVP            | 929    | 934   | 942    | tHP  |      |
|                     | Frequency              | f <sub>v</sub> | 50     | 60    | 75     | Hz   |      |
|                     | Width                  | tWV            | 6      | 6     | 6      | tHP  |      |
| DE<br>(Data Enable) | Horizontal Valid       | tHV            | 720    | 720   | 720    | tCLK |      |
|                     | Horizontal Back Porch  | tHBP           | 108    | 116   | 124    |      |      |
|                     | Horizontal Front Porch | tHFP           | 36     | 40    | 48     |      |      |
|                     | -                      | -              | -      | -     | -      |      |      |
|                     | Vertical Valid         | tVV            | 900    | 900   | 900    | tHP  |      |
|                     | Vertical Back Porch    | tVBP           | 20     | 25    | 33     |      |      |
|                     | Vertical Front Porch   | tVFP           | 3      | 3     | 3      |      |      |
|                     | -                      | -              | -      | -     | -      |      |      |

**Note:** Hsync period and Hsync width-active should be even number times of tCLK. If the value is odd number times of tCLK, display control signal can be asynchronous. In order to operate this LCM a Hsync, Vsync, and DE(data enable) signals should be used.

1. The performance of the electro-optical characteristics may be influenced by variance of the vertical refresh rates.
2. Vsync and Hsync should keep the above specification.
3. Hsync Period, Hsync Width, and Horizontal Back Porch should be any times of of character number(8).
4. The polarity of Hsync is not restricted.

Product Specification

### 3-4. Signal Timing Waveforms

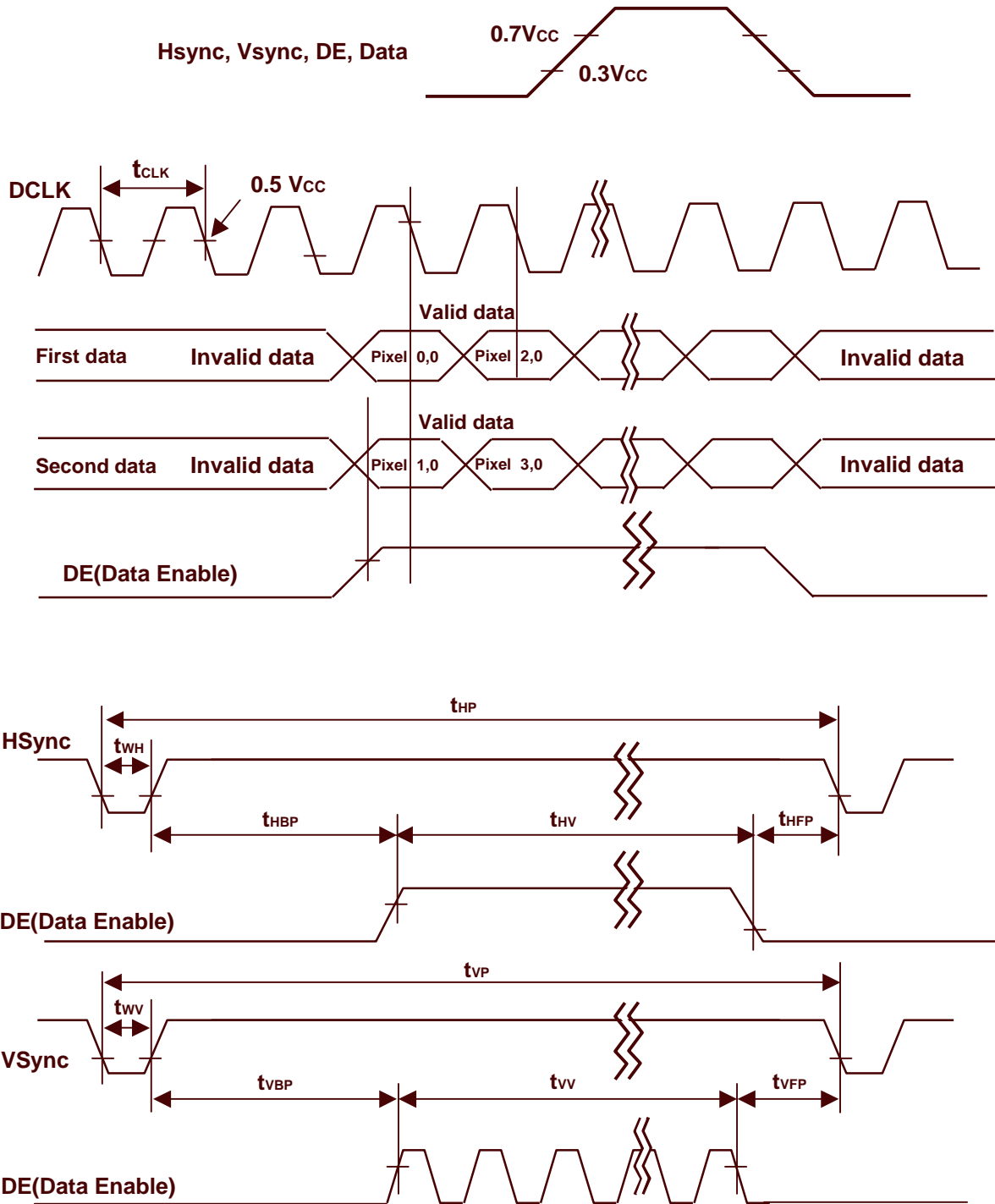

Product Specification

### 3-5. Color Data Reference

The brightness of each primary color (red, green and blue) is based on the 8-bit gray scale data input for the color ; the higher the binary input, the brighter the color. The table below provides a reference for color versus data input.

**Table 6. COLOR DATA REFERENCE**

| Color       |                   | Input Color Data |    |    |    |     |    |    |    |       |    |    |    |     |    |    |    |      |    |    |    |     |    |    |    |
|-------------|-------------------|------------------|----|----|----|-----|----|----|----|-------|----|----|----|-----|----|----|----|------|----|----|----|-----|----|----|----|
|             |                   | Red              |    |    |    |     |    |    |    | Green |    |    |    |     |    |    |    | Blue |    |    |    |     |    |    |    |
|             |                   | MSB              |    |    |    | LSB |    |    |    | MSB   |    |    |    | LSB |    |    |    | MSB  |    |    |    | LSB |    |    |    |
|             |                   | R7               | R6 | R5 | R4 | R3  | R2 | R1 | R0 | G7    | G6 | G5 | G4 | G3  | G2 | G1 | G0 | B7   | B6 | B5 | B4 | B3  | B2 | B1 | B0 |
| Basic Color | Black             | 0                | 0  | 0  | 0  | 0   | 0  | 0  | 0  | 0     | 0  | 0  | 0  | 0   | 0  | 0  | 0  | 0    | 0  | 0  | 0  | 0   | 0  | 0  | 0  |
|             | Red (255)         | 1                | 1  | 1  | 1  | 1   | 1  | 1  | 1  | 0     | 0  | 0  | 0  | 0   | 0  | 0  | 0  | 0    | 0  | 0  | 0  | 0   | 0  | 0  | 0  |
|             | Green (255)       | 0                | 0  | 0  | 0  | 0   | 0  | 0  | 0  | 1     | 1  | 1  | 1  | 1   | 1  | 1  | 1  | 0    | 0  | 0  | 0  | 0   | 0  | 0  | 0  |
|             | Blue (255)        | 0                | 0  | 0  | 0  | 0   | 0  | 0  | 0  | 0     | 0  | 0  | 0  | 0   | 0  | 0  | 0  | 1    | 1  | 1  | 1  | 1   | 1  | 1  | 1  |
|             | Cyan              | 0                | 0  | 0  | 0  | 0   | 0  | 0  | 0  | 1     | 1  | 1  | 1  | 1   | 1  | 1  | 1  | 1    | 1  | 1  | 1  | 1   | 1  | 1  | 1  |
|             | Magenta           | 1                | 1  | 1  | 1  | 1   | 1  | 1  | 1  | 0     | 0  | 0  | 0  | 0   | 0  | 0  | 0  | 1    | 1  | 1  | 1  | 1   | 1  | 1  | 1  |
|             | Yellow            | 1                | 1  | 1  | 1  | 1   | 1  | 1  | 1  | 1     | 1  | 1  | 1  | 1   | 1  | 1  | 1  | 0    | 0  | 0  | 0  | 0   | 0  | 0  | 0  |
|             | White             | 1                | 1  | 1  | 1  | 1   | 1  | 1  | 1  | 1     | 1  | 1  | 1  | 1   | 1  | 1  | 1  | 1    | 1  | 1  | 1  | 1   | 1  | 1  | 1  |
| Red         | Red(000) Dark     | 0                | 0  | 0  | 0  | 0   | 0  | 0  | 0  | 0     | 0  | 0  | 0  | 0   | 0  | 0  | 0  | 0    | 0  | 0  | 0  | 0   | 0  | 0  | 0  |
|             | Red(001)          | 0                | 0  | 0  | 0  | 0   | 0  | 0  | 1  | 0     | 0  | 0  | 0  | 0   | 0  | 0  | 0  | 0    | 0  | 0  | 0  | 0   | 0  | 0  | 0  |
|             | Red(002)          | 0                | 0  | 0  | 0  | 0   | 0  | 1  | 0  | 0     | 0  | 0  | 0  | 0   | 0  | 0  | 0  | 0    | 0  | 0  | 0  | 0   | 0  | 0  | 0  |
|             | -----             | -                | -  | -  | -  | -   | -  | -  | -  | -     | -  | -  | -  | -   | -  | -  | -  | -    | -  | -  | -  | -   | -  | -  | -  |
|             | -----             | -                | -  | -  | -  | -   | -  | -  | -  | -     | -  | -  | -  | -   | -  | -  | -  | -    | -  | -  | -  | -   | -  | -  | -  |
|             | Red(253)          | 1                | 1  | 1  | 1  | 1   | 1  | 0  | 1  | 0     | 0  | 0  | 0  | 0   | 0  | 0  | 0  | 0    | 0  | 0  | 0  | 0   | 0  | 0  | 0  |
|             | Red(254)          | 1                | 1  | 1  | 1  | 1   | 1  | 0  | 0  | 0     | 0  | 0  | 0  | 0   | 0  | 0  | 0  | 0    | 0  | 0  | 0  | 0   | 0  | 0  | 0  |
|             | Red(255) Bright   | 1                | 1  | 1  | 1  | 1   | 1  | 1  | 1  | 0     | 0  | 0  | 0  | 0   | 0  | 0  | 0  | 0    | 0  | 0  | 0  | 0   | 0  | 0  | 0  |
| Green       | Green(000) Dark   | 0                | 0  | 0  | 0  | 0   | 0  | 0  | 0  | 0     | 0  | 0  | 0  | 0   | 0  | 0  | 0  | 0    | 0  | 0  | 0  | 0   | 0  | 0  | 0  |
|             | Green(001)        | 0                | 0  | 0  | 0  | 0   | 0  | 0  | 0  | 0     | 0  | 0  | 0  | 0   | 0  | 1  | 0  | 0    | 0  | 0  | 0  | 0   | 0  | 0  | 0  |
|             | Green(002)        | 0                | 0  | 0  | 0  | 0   | 0  | 0  | 0  | 0     | 0  | 0  | 0  | 0   | 0  | 1  | 0  | 0    | 0  | 0  | 0  | 0   | 0  | 0  | 0  |
|             | -----             | -                | -  | -  | -  | -   | -  | -  | -  | -     | -  | -  | -  | -   | -  | -  | -  | -    | -  | -  | -  | -   | -  | -  | -  |
|             | -----             | -                | -  | -  | -  | -   | -  | -  | -  | -     | -  | -  | -  | -   | -  | -  | -  | -    | -  | -  | -  | -   | -  | -  | -  |
|             | Green(253)        | 0                | 0  | 0  | 0  | 0   | 0  | 0  | 0  | 1     | 1  | 1  | 1  | 1   | 1  | 0  | 1  | 0    | 0  | 0  | 0  | 0   | 0  | 0  | 0  |
|             | Green(254)        | 0                | 0  | 0  | 0  | 0   | 0  | 0  | 0  | 1     | 1  | 1  | 1  | 1   | 1  | 1  | 0  | 0    | 0  | 0  | 0  | 0   | 0  | 0  | 0  |
|             | Green(255) Bright | 0                | 0  | 0  | 0  | 0   | 0  | 0  | 0  | 1     | 1  | 1  | 1  | 1   | 1  | 1  | 1  | 0    | 0  | 0  | 0  | 0   | 0  | 0  | 0  |
| Blue        | Blue(000) Dark    | 0                | 0  | 0  | 0  | 0   | 0  | 0  | 0  | 0     | 0  | 0  | 0  | 0   | 0  | 0  | 0  | 0    | 0  | 0  | 0  | 0   | 0  | 0  | 0  |
|             | Blue(001)         | 0                | 0  | 0  | 0  | 0   | 0  | 0  | 0  | 0     | 0  | 0  | 0  | 0   | 0  | 0  | 0  | 0    | 0  | 0  | 0  | 0   | 0  | 0  | 1  |
|             | Blue(002)         | 0                | 0  | 0  | 0  | 0   | 0  | 0  | 0  | 0     | 0  | 0  | 0  | 0   | 0  | 0  | 0  | 0    | 0  | 0  | 0  | 0   | 0  | 0  | 1  |
|             | -----             | -                | -  | -  | -  | -   | -  | -  | -  | -     | -  | -  | -  | -   | -  | -  | -  | -    | -  | -  | -  | -   | -  | -  | -  |
|             | -----             | -                | -  | -  | -  | -   | -  | -  | -  | -     | -  | -  | -  | -   | -  | -  | -  | -    | -  | -  | -  | -   | -  | -  | -  |
|             | Blue(253)         | 0                | 0  | 0  | 0  | 0   | 0  | 0  | 0  | 0     | 0  | 0  | 0  | 0   | 0  | 0  | 1  | 1    | 1  | 1  | 1  | 1   | 1  | 0  | 1  |
|             | Blue(254)         | 0                | 0  | 0  | 0  | 0   | 0  | 0  | 0  | 0     | 0  | 0  | 0  | 0   | 0  | 0  | 1  | 1    | 1  | 1  | 1  | 1   | 1  | 1  | 0  |
|             | Blue(255) Bright  | 0                | 0  | 0  | 0  | 0   | 0  | 0  | 0  | 0     | 0  | 0  | 0  | 0   | 0  | 0  | 1  | 1    | 1  | 1  | 1  | 1   | 1  | 1  | 1  |

Product Specification

### 3-6. Power Sequence

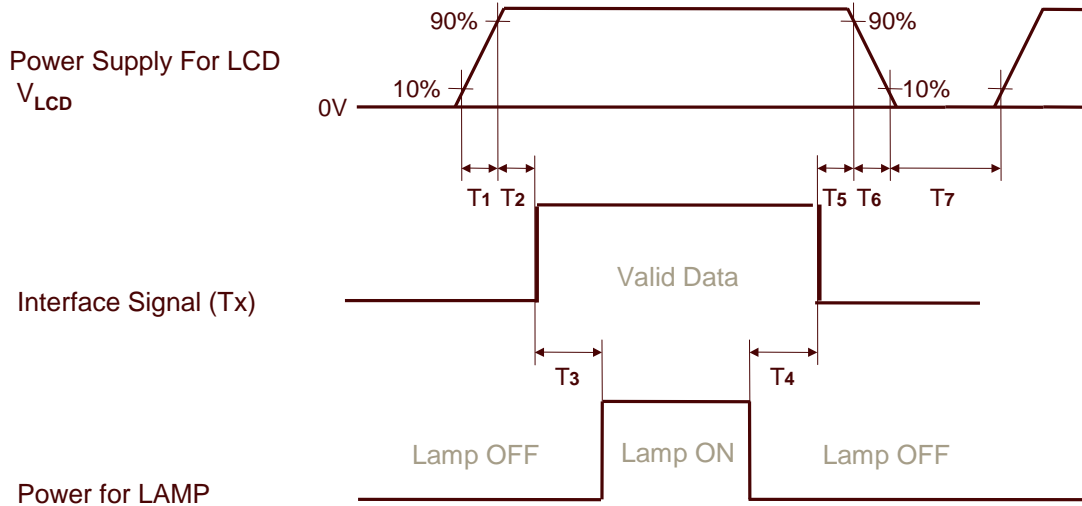

**Table 7. POWER SEQUENCE**

| Parameter | Values |     |     | Units |
|-----------|--------|-----|-----|-------|
|           | Min    | Typ | Max |       |
| T1        | 0.5    | -   | 10  | ms    |
| T2        | 0.0    | -   | 50  | ms    |
| T3        | 500    | -   | -   | ms    |
| T4        | 200    | -   | -   | ms    |
| T5        | 0.0    | -   | 50  | ms    |
| T7        | 1      | -   | -   | ms    |

- Notes :
1. Please avoid floating state of interface signal at invalid period.
  2. When the interface signal is invalid, be sure to pull down the power supply for LCD  $V_{LCD}$  to 0V.
  3. Lamp power must be turn on after power supply for LCD an interface signal are valid.

Product Specification

### 3-7. $V_{LCD}$ Power Dip Condition

The  $V_{LCD}$  dip condition is caused by the PWM IC initialization.

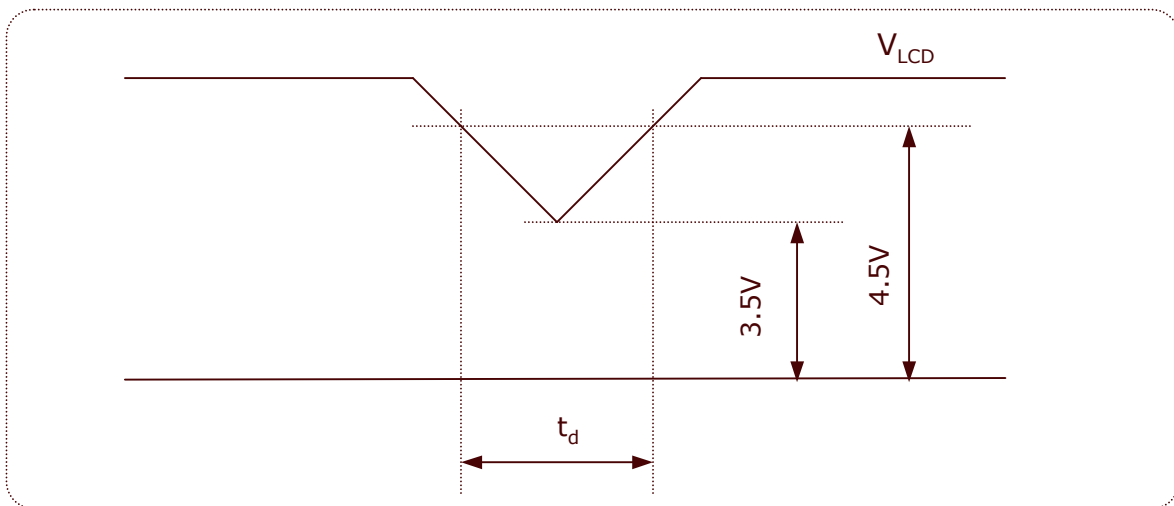

1) Dip condition

$$3.5V \leq V_{LCD} < 4.5V, \quad t_d \leq 20ms$$

2)  $V_{LCD} < 3.5V$

$V_{LCD}$ -dip conditions should also follow the Power On/Off conditions for supply voltage.

Product Specification

### 4. Optical Specification

Optical characteristics are determined after the unit has been 'ON' and stable for approximately 30 minutes in a dark environment at  $25 \pm 2^\circ\text{C}$ . The values specified are at an approximate distance 50cm from the LCD surface at a viewing angle of  $\Phi$  and  $\theta$  equal to  $0^\circ$ .

FIG. 1 presents additional information concerning the measurement equipment and method.

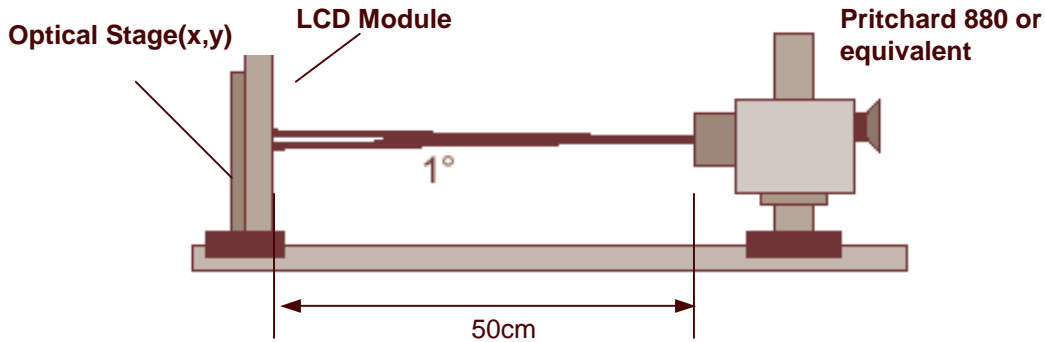

**FIG. 1 Optical Characteristic Measurement Equipment and Method**

**Table 7. OPTICAL CHARACTERISTICS**

$T_a = 25 \pm 2^\circ\text{C}$ ,  $V_{LCD} = 5.0\text{V}$ ,  $f_v = 60\text{Hz}$ ,  $D_{clk} = 106.5\text{MHz}$ ,  $I_{Lamp} = 8\text{mA}$

| Parameter                   | Symbol                            | Values     |              |       | Units             | Notes  |   |
|-----------------------------|-----------------------------------|------------|--------------|-------|-------------------|--------|---|
|                             |                                   | Min        | Typ          | Max   |                   |        |   |
| Contrast Ratio              | CR                                | 500        | 800          | -     |                   | 1      |   |
| Surface Luminance, white    | $L_{WH}$                          | 200        | 250          | -     | cd/m <sup>2</sup> | 2      |   |
| Luminance Variation         | $\delta_{WHITE}$                  | 75         |              |       | %                 | 3      |   |
| Response Time               | Rise Time                         | $Tr_R$     | -            | 2     | 5                 | ms     | 4 |
|                             | Decay Time                        | $Tr_D$     | -            | 6     | 11                | ms     |   |
| Color Coordinates [CIE1931] | RED                               | $R_x$      | Typ<br>-0.03 | 0.609 | Typ<br>+0.03      |        |   |
|                             |                                   | $R_y$      |              | 0.339 |                   |        |   |
|                             | GREEN                             | $G_x$      |              | 0.307 |                   |        |   |
|                             |                                   | $G_y$      |              | 0.592 |                   |        |   |
|                             | BLUE                              | $B_x$      |              | 0.150 |                   |        |   |
|                             |                                   | $B_y$      |              | 0.095 |                   |        |   |
|                             | WHITE                             | $W_x$      |              | 0.313 |                   |        |   |
|                             | $W_y$                             | 0.329      |              |       |                   |        |   |
| Viewing Angle (CR>10)       |                                   |            | 160/160      |       |                   |        |   |
|                             | x axis, right( $\phi=0^\circ$ )   | $\theta_r$ | 70           | 80    | -                 | degree | 5 |
|                             | x axis, left ( $\phi=180^\circ$ ) | $\theta_l$ | 70           | 80    | -                 |        |   |
|                             | y axis, up ( $\phi=90^\circ$ )    | $\theta_u$ | 60           | 75    | -                 |        |   |
|                             | y axis, down ( $\phi=270^\circ$ ) | $\theta_d$ | 70           | 85    | -                 |        |   |
| Gray Scale                  |                                   | 1.9        | 2.2          | 2.5   |                   | 6      |   |
| Cross talk                  |                                   |            |              | 1.5   | %                 | Fig 5  |   |



**Product Specification**

Notes 1. Contrast Ratio(CR) is defined mathematically as :

$$\text{Contrast Ratio} = \frac{\text{Surface Luminance with all white pixels}}{\text{Surface Luminance with all black pixels}} \text{ at center point (1)}$$

2. Surface luminance is the luminance value at center 1 point(1) across the LCD surface 50cm from the surface with all pixels displaying white. For more information see FIG 2.

3. The variation in surface luminance ,  $\delta$  WHITE is defined as :

$$\delta_{\text{WHITE}} = \frac{\text{Minimum (P1,P2 .....P9)}}{\text{Maximum (P1,P2 .....P9)}} * 100$$

For more information see FIG 2.

4. Response time is the time required for the display to transition from white to black(Rise Time,  $Tr_R$ ) and from black to white(Decay Time,  $Tr_D$ ). For additional information see FIG 3.

5. Viewing angle is the angle at which the contrast ratio is greater than 10. The angles are determined for the horizontal or x axis and the vertical or y axis with respect to the z axis which is normal to the LCD surface. For more information see FIG 4.

6. Gray scale specification

**Table 8. Gray Scale Specification**

| Gray Level | Luminance [%] (Typ) |
|------------|---------------------|
| L0         | 0.12                |
| L15        | 0.30                |
| L31        | 1.2                 |
| L47        | 2.4                 |
| L63        | 4.57                |
| L79        | 7.52                |
| L95        | 11.3                |
| L111       | 15.9                |
| L127       | 21.4                |
| L143       | 27.8                |
| L159       | 35.2                |
| L175       | 43.5                |
| L191       | 52.8                |
| L207       | 63.1                |
| L223       | 74.4                |
| L239       | 86.7                |
| L255       | 100                 |

Product Specification

Measuring point for surface luminance & measuring point for luminance variation

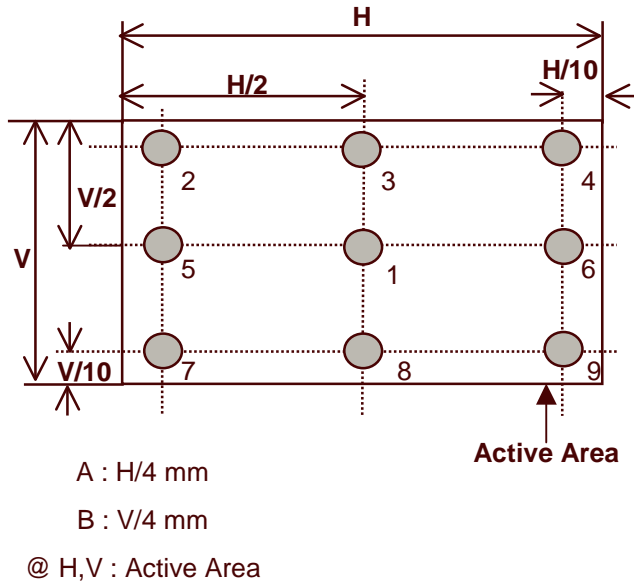

**FIG. 2 Measure Point for Luminance**

The response time is defined as the following figure and shall be measured by switching the input signal for “black” and “white”.

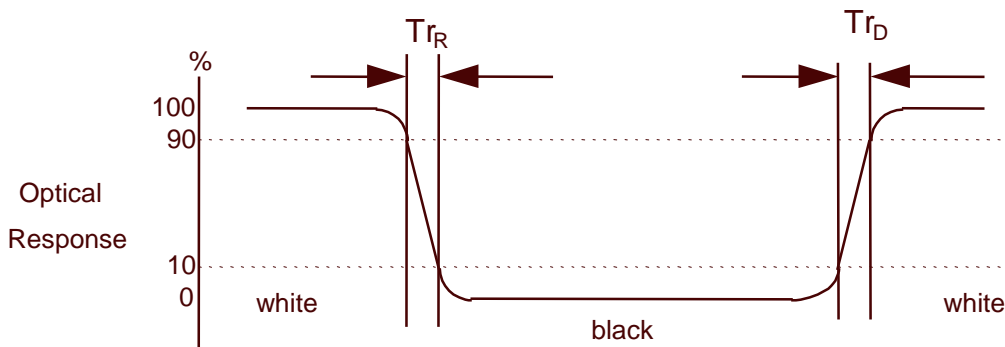

**FIG. 3 Response Time**

Product Specification

Dimension of viewing angle range

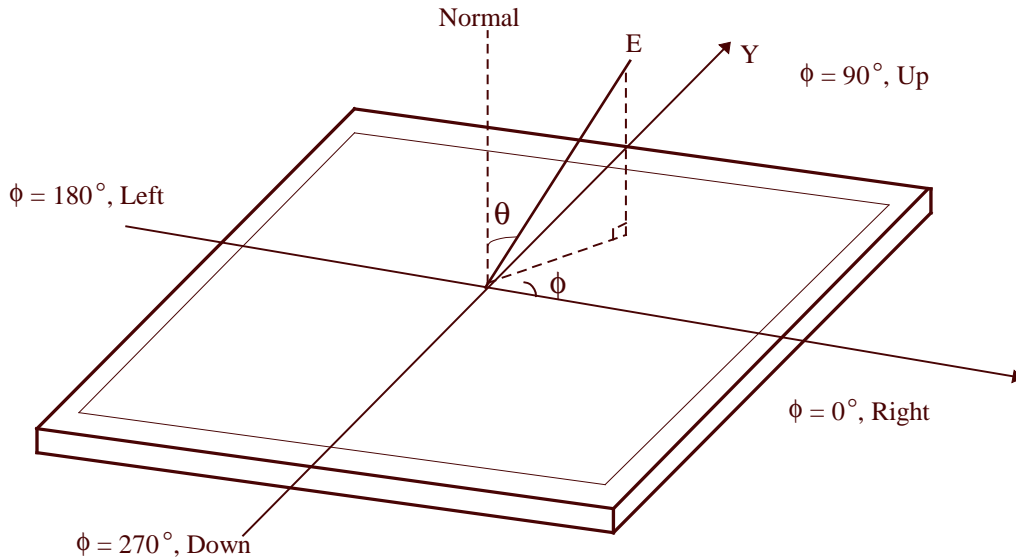

FIG. 4 Viewing angle

The equation of crosstalk :  $(|L_{A[or C]2} - L_{A[or C]1}| / L_{A[or C]1}) \times 100(\%)$  [Vertical],  
 $(|L_{B[or D]2} - L_{B[or D]1}| / L_{B[or D]1}) \times 100(\%)$  [Horizontal]

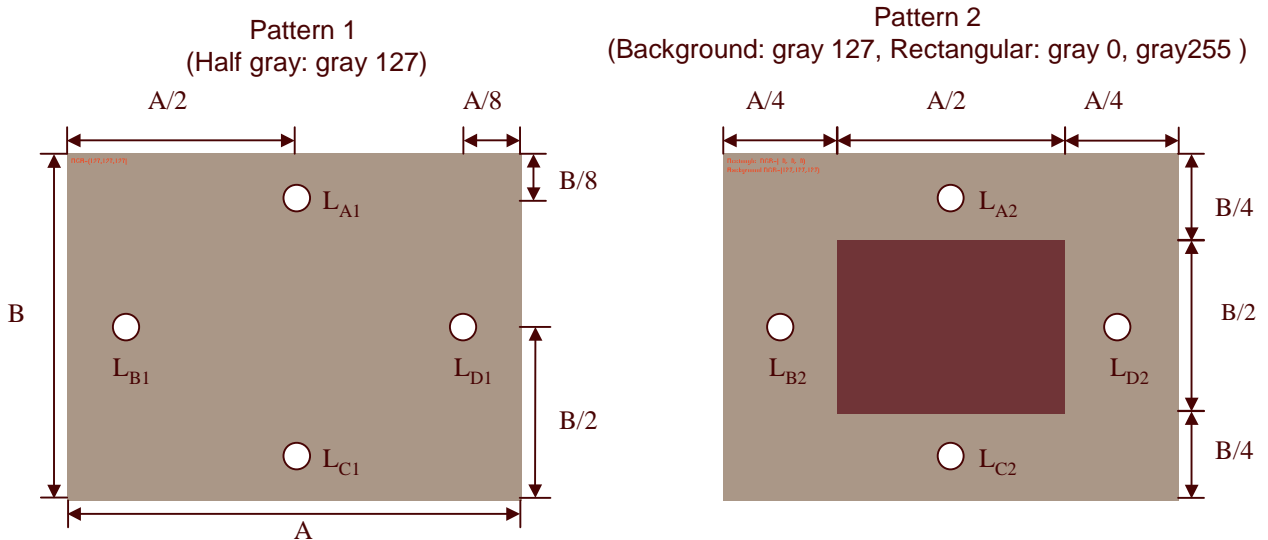

Figure 5. Crosstalk

Product Specification

### 5. Mechanical Characteristics

The contents provide general mechanical characteristics. In addition the figures in the next page are detailed mechanical drawing of the LCD.

|                     |                                        |          |
|---------------------|----------------------------------------|----------|
| Outline Dimension   | Horizontal                             | 389.2mm  |
|                     | Vertical                               | 254.5mm  |
|                     | Depth                                  | 11.5mm   |
| Bezel Area          | Horizontal                             | 370.6 mm |
|                     | Vertical                               | 232.9 mm |
| Active Display Area | Horizontal                             | 367.2mm  |
|                     | Vertical                               | 229.5mm  |
| Weight              | 1360 g(Typ.), 1,430 g(Max.)            |          |
| Surface Treatment   | Glare treatment of the front polarizer |          |

Notes : Please refer to a mechanic drawing in terms of tolerance at the next page.

Product Specification

<FRONT VIEW>

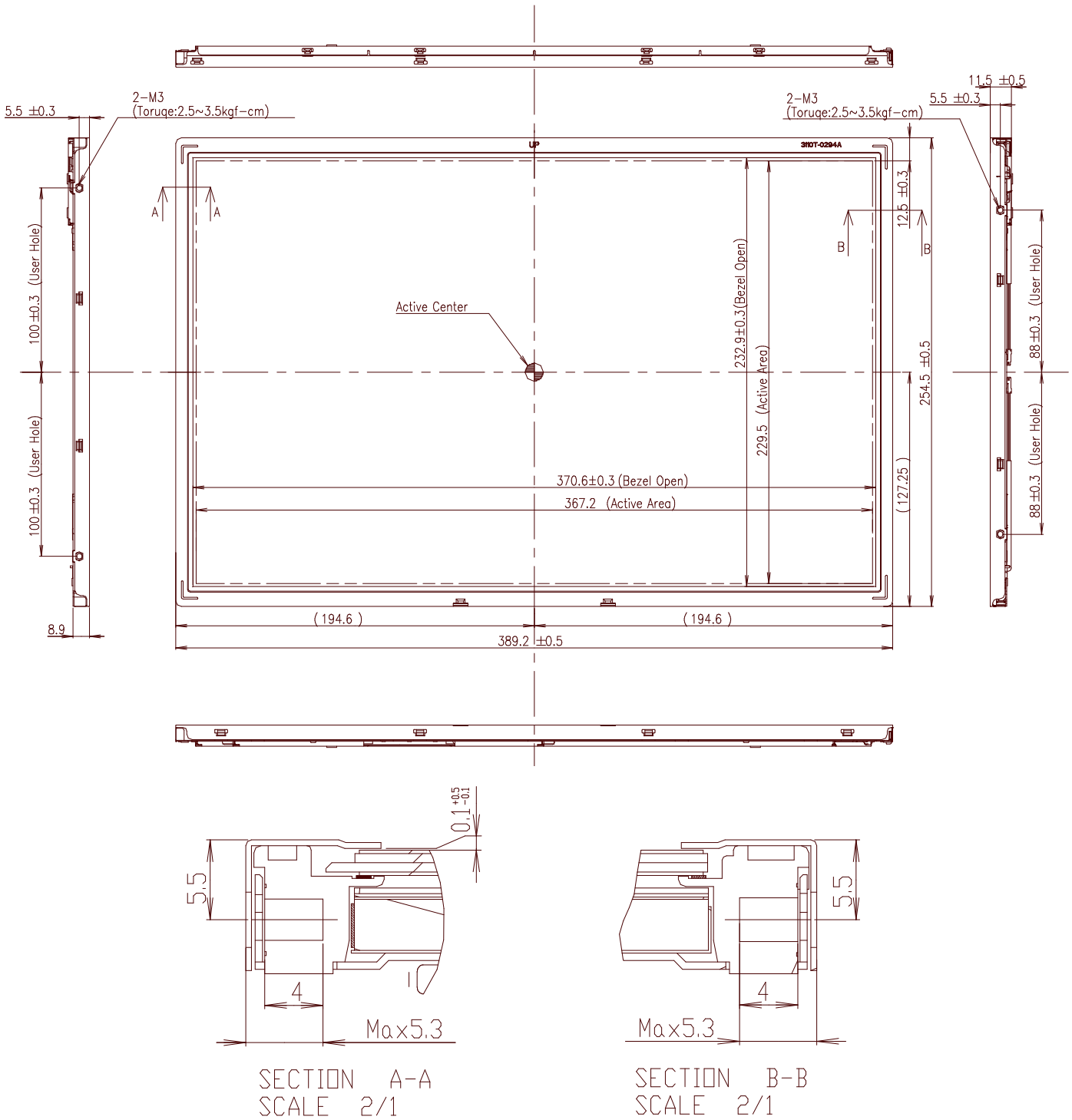

Product Specification

<REAR VIEW>

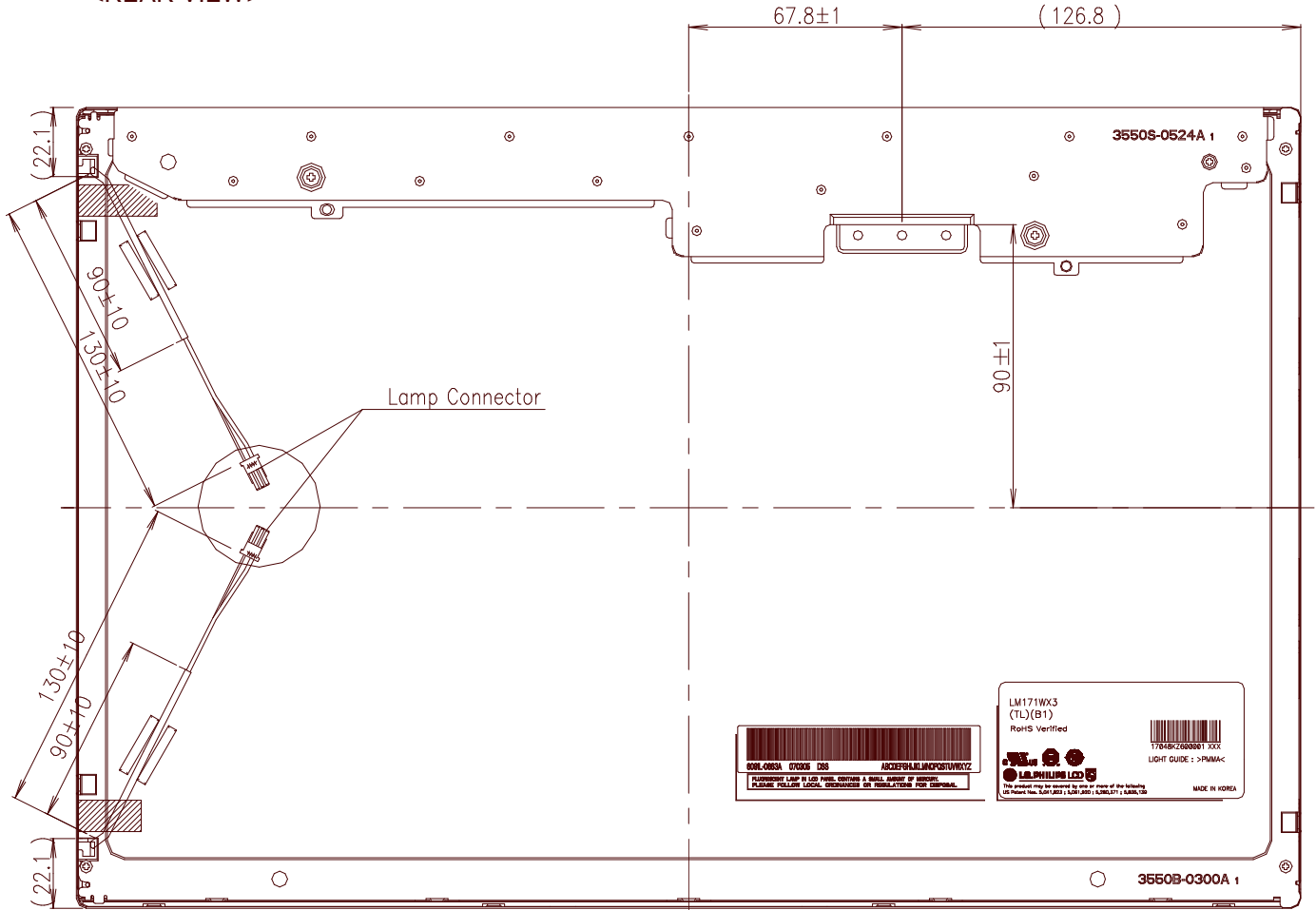

NOTES

1. Unspecified tolerances to be  $\pm 0.5$
2. Backlight wires and contraction tubes are excluded from outline dimensions.
3. Tilt and partial disposition tolerance of display area as following.
  - (1) Y-Direction :  $|A-B| \leq 1.0$
  - (2) X-Direction :  $|C-D| \leq 1.0$

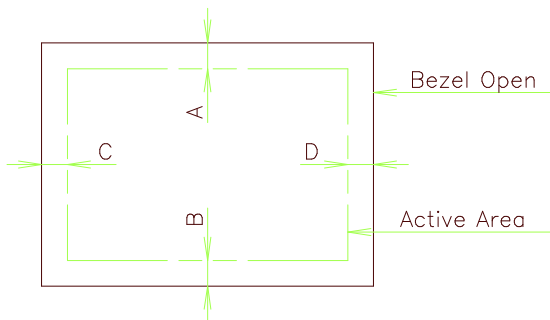

4. Do not wind conductive tape around the backlight wires.
5. Lamp Connector Specification.
  - 20015HS-03LB(GRAY) (YEONHO)

Product Specification

## 6. Reliability

Environment test condition

| No | Test Item                                   | Condition                                                                                                                          |
|----|---------------------------------------------|------------------------------------------------------------------------------------------------------------------------------------|
| 1  | High temperature storage test               | Ta= 60°C 240h                                                                                                                      |
| 2  | Low temperature storage test                | Ta= -20°C 240h                                                                                                                     |
| 3  | High temperature operation test             | Ta= 50°C 50%RH 240h                                                                                                                |
| 4  | Low temperature operation test              | Ta= 0°C 240h                                                                                                                       |
| 5  | Vibration test<br>(non-operating)           | Wave form : random<br>Vibration level : 1.15G RMS<br>Bandwidth : 1-200Hz<br>Duration : ±X,±Y,±Z, 30 min<br>One time each direction |
| 6  | Shock test<br>(non-operating)               | Shock level : 120G<br>Waveform : half sine wave, 2ms<br>Direction : ± X, ± Y, ± Z<br>One time each direction                       |
| 7  | Altitude<br>operating<br>storage / shipment | 0 - 10,000 feet(3048m)<br>0 - 40,000 feet(12,192m)                                                                                 |

## 7. International Standards

### 7-1. Safety

- a) UL 60950-1:2003, First Edition, Underwriters Laboratories, Inc., Standard for Safety of Information Technology Equipment.
- b) CAN/CSA C22.2, No. 60950-1-03 1<sup>st</sup> Ed. April 1, 2003, Canadian Standards Association, Standard for Safety of Information Technology Equipment.
- c) EN 60950-1:2001, First Edition, European Committee for Electrotechnical Standardization(CENELEC) European Standard for Safety of Information Technology Equipment.
- d) RoHS, Directive 2002/95/EC of the European Parliament and of the council of 27 January 2003

### 7-2. EMC

- a) ANSI C63.4 "Methods of Measurement of Radio-Noise Emissions from Low-Voltage Electrical and Electrical Equipment in the Range of 9kHz to 40GHz. "American National Standards Institute(ANSI), 1992
- b) C.I.S.P.R "Limits and Methods of Measurement of Radio Interface Characteristics of Information Technology Equipment." International Special Committee on Radio Interference.
- c) EN 55022 "Limits and Methods of Measurement of Radio Interface Characteristics of Information Technology Equipment." European Committee for Electrotechnical Standardization.(CENELEC), 1998 ( Including A1: 2000 )



Product Specification

## 8. Packing

### 8-1. Designation of Lot Mark

a) Lot Mark

|   |   |   |   |   |   |   |   |   |   |   |   |   |
|---|---|---|---|---|---|---|---|---|---|---|---|---|
| A | B | C | D | E | F | G | H | I | J | K | L | M |
|---|---|---|---|---|---|---|---|---|---|---|---|---|

A,B,C : SIZE(INCH)  
E : MONTH

D : YEAR  
F~M : SERIAL NO.

Note

1. YEAR

|      |      |      |      |      |      |      |      |      |      |      |
|------|------|------|------|------|------|------|------|------|------|------|
| Year | 2001 | 2002 | 2003 | 2004 | 2005 | 2006 | 2007 | 2008 | 2009 | 2010 |
| Mark | 1    | 2    | 3    | 4    | 5    | 6    | 7    | 8    | 9    | 0    |

2. MONTH

|       |     |     |     |     |     |     |     |     |     |     |     |     |
|-------|-----|-----|-----|-----|-----|-----|-----|-----|-----|-----|-----|-----|
| Month | Jan | Feb | Mar | Apr | May | Jun | Jul | Aug | Sep | Oct | Nov | Dec |
| Mark  | 1   | 2   | 3   | 4   | 5   | 6   | 7   | 8   | 9   | A   | B   | C   |

b) Location of Lot Mark

Serial No. is printed on the label. The label is attached to the backside of the LCD module.  
This is subject to change without prior notice.

### 8-2. Packing Form

- a) Package quantity in one box : 12 pcs
- b) Box size : 359mm X 330mm X 458mm.

## Product Specification

## 9. PRECAUTIONS

Please pay attention to the followings when you use this TFT LCD module.

### 9-1. MOUNTING PRECAUTIONS

- (1) You must mount a module using holes arranged in four corners or four sides.
- (2) You should consider the mounting structure so that uneven force (ex. Twisted stress) is not applied to the module. And the case on which a module is mounted should have sufficient strength so that external force is not transmitted directly to the module.
- (3) Please attach the surface transparent protective plate to the surface in order to protect the polarizer. Transparent protective plate should have sufficient strength in order to resist external force.
- (4) You should adopt radiation structure to satisfy the temperature specification.
- (5) Acetic acid type and chlorine type materials for the cover case are not desirable because the former generates corrosive gas of attacking the polarizer at high temperature and the latter causes circuit break by electro-chemical reaction.
- (6) Do not touch, push or rub the exposed polarizers with glass, tweezers or anything harder than HB pencil lead. And please do not rub with dust clothes with chemical treatment. Do not touch the surface of polarizer for bare hand or greasy cloth. (Some cosmetics are detrimental to the polarizer.)
- (7) When the surface becomes dusty, please wipe gently with absorbent cotton or other soft materials like chamois soaks with petroleum benzene. Normal-hexane is recommended for cleaning the adhesives used to attach front / rear polarizers. Do not use acetone, toluene and alcohol because they cause chemical damage to the polarizer.
- (8) Wipe off saliva or water drops as soon as possible. Their long time contact with polarizer causes deformations and color fading.
- (9) Do not open the case because inside circuits do not have sufficient strength.

### 9-2. OPERATING PRECAUTIONS

- (1) The spike noise causes the mis-operation of circuits. It should be lower than following voltage :  
 $V = \pm 200\text{mV}$  (Over and under shoot voltage)
- (2) Response time depends on the temperature. (In lower temperature, it becomes longer.)
- (3) Brightness depends on the temperature. (In lower temperature, it becomes lower.)  
And in lower temperature, response time (required time that brightness is stable after turned on) becomes longer.
- (4) Be careful for condensation at sudden temperature change. Condensation makes damage to polarizer or electrical contacted parts. And after fading condensation, smear or spot will occur.
- (5) When fixed patterns are displayed for a long time, remnant image is likely to occur.
- (6) Module has high frequency circuits. Sufficient suppression to the electromagnetic interference shall be done by system manufacturers. Grounding and shielding methods may be important to minimize the interference.
- (7) Please do not give any mechanical and/or acoustical impact to LCM. Otherwise, LCM can not be operated its full characteristics perfectly.
- (8) A screw which is fastened up the steels should be a machine screw (if not, it causes metallic foreign material and deal LCM a fatal blow)
- (9) Please do not set LCD on its edge.

## Product Specification

**9-3. ELECTROSTATIC DISCHARGE CONTROL**

Since a module is composed of electronic circuits, it is not strong to electrostatic discharge. Make certain that treatment persons are connected to ground through wrist band etc. And don't touch interface pin directly.

**9-4. PRECAUTIONS FOR STRONG LIGHT EXPOSURE**

Strong light exposure causes degradation of polarizer and color filter.

**9-5. STORAGE**

When storing modules as spares for a long time, the following precautions are necessary.

- (1) Store them in a dark place. Do not expose the module to sunlight or fluorescent light. Keep the temperature between 5°C and 35°C at normal humidity.
- (2) The polarizer surface should not come in contact with any other object.  
It is recommended that they be stored in the container in which they were shipped.

**9-6. HANDLING PRECAUTIONS FOR PROTECTION FILM**

- (1) The protection film is attached to the bezel with a small masking tape.  
When the protection film is peeled off, static electricity is generated between the film and polarizer. This should be peeled off slowly and carefully by people who are electrically grounded and with well ion-blown equipment or in such a condition, etc.
- (2) When the module with protection film attached is stored for a long time, sometimes there remains a very small amount of glue still on the bezel after the protection film is peeled off.
- (3) You can remove the glue easily. When the glue remains on the bezel surface or its vestige is recognized, please wipe them off with absorbent cotton waste or other soft material like chamois soaked with normal-hexane.