

SPECIFICATION

For

APPROVAL

- () Preliminary Specification
 () Final Specification

Title	18.1" SXGA TFT LCD
-------	--------------------

BUYER NAME	
MODEL NAME	

SUPPLIER	LG Electronics Inc.
MODEL NAME	LM181E1

SIGNATURE	DATE
_____/_____ 	_____
_____/_____ 	_____
_____/_____ 	_____

APPROVED BY	DATE
_____/G.Manager 	_____
REVIEWED BY	
_____/S.Engineer 	_____
PREPARED BY	
_____/S.Engineer 	_____

Please return 1 copy for our confirmation with your signature and comments.

**Product Engineering Dept.
LCD Division LG Electronics Inc.**

CONTENTS

NO.	ITEM	Page
-	COVER	1
-	CONTENTS	2
1.	GENERAL DESCRIPTION	3
2.	MAXIMUM RATINGS	4
3.	ELECTRICAL SPECIFICATIONS	4
4.	OPTICAL SPECIFICATIONS	5
5.	INTERFACE CONNECTION	6
6.	SIGNAL TIMING SPECIFICATIONS	7
7.	SIGNAL TIMING WAVE FORMS	8
8.	COLOR INPUT DATA REFERENCE	9
9.	POWER SEQUENCE	10
10.	MECHANICAL CHARACTERISTICS	11
11.	RELIABILITY	12
12.	PRECAUTIONS	13
-	APPENDIX	14-15

1. General Description

The LG Electronics model LM181E1 LCD is a Color Active Matrix Liquid Crystal Display with an integral Cold Cathode Fluorescent Tube(CCFT) back light system. The matrix employs a-Si Thin Film Transistor as the active element. It is a transmissive type display operating in the normally white mode. This TFT-LCD has a 18.1 inch diagonally measured active display area with SXGA resolution(1024 vertical by 1280 horizontal pixel array). Each pixel is divided into Red, Green and Blue sub-pixels or dots which are arranged in vertical stripes. Gray scale or the brightness of the sub-pixel color is determined with a 8-bit gray scale signal for each dot, thus, presenting a palette of more than 16,581,375 colors.

LM181E1 has been designed to apply the interface method that enables low power, high speed low EMI. FPD-Link must be used as a LVDS(Low Voltage Differential Signaling) chip.

The LM181E1 LCD is intended to support applications where high brightness, wide viewing angle are critical factors and graphic displays are important. In combination with the vertical arrangement of the sub-pixels, the LM181E1 characteristics provide an excellent flat panel display for office automation products such as monitors.

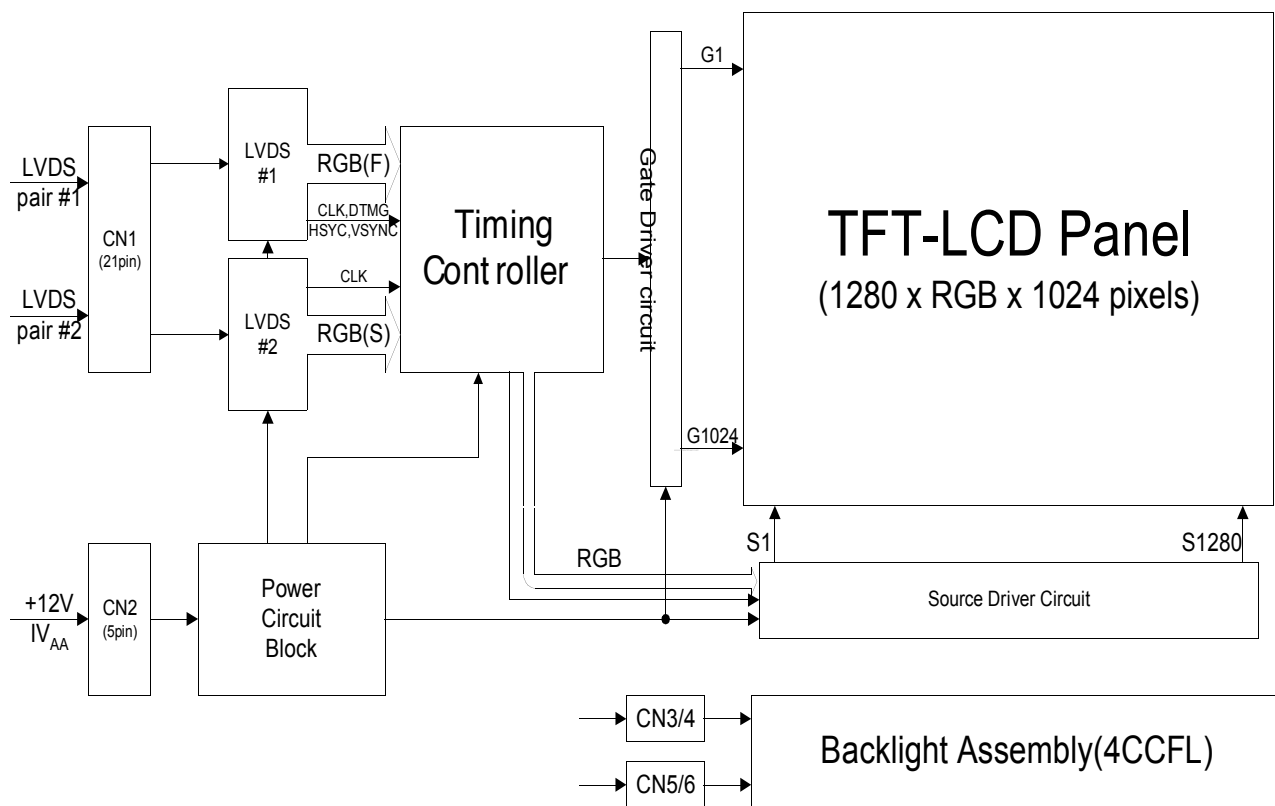

General Display Characteristics

The following are general feature of the model LM181E1 LCD;

Active display area	18.1 inches(45.97cm) diagonal
Outsize dimensions	413.0w * 333.0h * 21.5t(typ)mm(Without Inverter)
Pixel pitch	0.2805 mm 0.2805 mm
Pixel format	1280 horiz. By 1024 vert. pixels
	RGB stripe arrangement
Color depth	8-bit, 16,581,375 colors
Display operating mode	transmissive mode, normally black
Surface treatments	hard coating(3H), anti-glare treatment of the front polarizer

2. Maximum Ratings

The following are maximum values which, if exceeded, may cause faulty operation or damage to the unit.

Product Specification
Table 1 ABSOLUTE MAXIMUM RATINGS

Parameter	symbol	Values		Units	Notes
		Min.	Max.		
Power Input Voltage	$I_{V_{AA}}$	0	+13.2	V_{DC}	at 25 25 1
Operating Temperature	T_{OP}	0	+50		
Storage Temperature	T_{ST}	-20	+60		

Note: 1. The Relative Humidity must not exceed 95% non-condensing at temperatures of 40 or less. At temperatures greater than 40, the wet bulb temperature must not exceed 39.

3. Electrical Specifications

The LM181E1 requires two power inputs. One is employed to power the LCD electronics and to drive the voltages to drive the TFT array and liquid crystal. The second input which powers the backlight CCFL, is typically generated by an inverter. The inverter is an external unit to the LCD.

Table 2 ELECTRICAL CHARACTERISTICS:

Parameter	Symbol	Values			Units	Notes
		Min.	Typ.	Max.		
MODULE:						
Power Supply Input Voltage	$I_{V_{AA}}$	10.8	12.0	13.2	V_{DC}	1
Power Supply Input Current	I_{IVAA}	-	0.65	1.2	A	1
Ripple/Noise		-	60	100	mV_{PP}	
Logic Input Level, High	V_{IH}	2.0	-	VCC	V_{DC}	2
Logic Input Level, Low	V_{IL}	$V_{SS}-0.2$	-	0.8	V_{DC}	2
Power Consumption	P_c	-	7.8	14.4	Watts	1
BACK LIGHT						
Back light Input voltage	V_{BL}	TBD	730	TBD	V_{RMS}	
Backlight Current	I_{BL}	TBD	8.0	TBD	mA	
Lamp Kick-Off Voltage		850	-	-	V_{RMS}	25 2
Operating Frequency	F_{BL}	30	-	60	KHz	
Power Consumption	P_{BL}	-	23.36	tbd	Watts	3

Notes: 1. The current draw and power consumption specified is for 12.0 Vdc at 25 and fv at 60Hz. The LCM is displayed the 8-gray pattern for the typical current. And the maximum current measurement condition is the vertical 2-line white/black pattern.
 2. Logic levels are specified for 3.3Vdc at FPD-Link chips, transmitter & receiver. The values specified apply to all logic inputs to FPD-Link; Hsync, Vsync, clock, data signals, etc.
 3. The backlight current consumption shown above does not include loss of external inverter.

Product Specification
4. Optical Specifications

Optical characteristics are determined after the unit has been 'ON' and stable for approximately 30 minutes in a dark environment at 25°. The values specified are at an approximate distance 50cm from the LCD surface at a viewing angle of Φ and θ equal to 0°. Appendix A presents additional information concerning the specified characteristics.

Table 2 OPTICAL CHARACTERISTICS

Parameter	Symbol	Values			Units	Notes
		Min.	Typ.	Max.		
Contrast Ratio	CR	180	200	-		1
Surface Brightness, white	SB _{WH}		200(TBD)	-	cd/m ²	2
Brightness Variation	SB _V	-	-	30	%	3
Response Time	Tr		50	70	msec	4
Rise Time	Tr _R	-	20	30		
Decay Time	Tr _D	-	30	40		
CIE Color Coordinates						
Red	X _R	0.573	0.603	0.633		
	y _R	0.314	0.344	0.374		
Green	X _G	0.283	0.313	0.343		
	y _G	0.521	0.551	0.581		
Blue	X _B	0.110	0.140	0.170		
	y _B	0.106	0.136	0.166		
White	X _W	0.292	0.322	0.352		
	y _W	0.326	0.356	0.386		
Viewing Angle					degree,	5
x axis, right (=0°)		70	-	-		
x axis, left(=180°)		70	-	-		
y axis, up(=90°)		70	-	-		
y axis, down (=270°)		70	-	-		

Notes 1. Contrast Ratio (CR) is defined mathematically as:

$$\frac{\text{(Surface Brightness with all white pixels)}}{\text{(Surface Brightness with all black pixels)}}$$

2. Surface brightness is the average of 5 measurement across the LCD surface 50cm from the surface with all pixels displaying white.

3. The variation in surface brightness, SB_V is determined by measuring B_{ON} at each test position 0 through 12, and then dividing the maximum B_{ON} - minimum B_{ON} by the average B_{ON}.

$$\frac{\text{Maximum (B}_{ON0}, \text{B}_{ON1}, \dots, \text{B}_{ON12})} - \text{Minimum (B}_{ON0}, \text{B}_{ON1}, \dots, \text{B}_{ON12})}{\text{Average (B}_{ON0}, \text{B}_{ON1}, \dots, \text{B}_{ON12})}$$

4. Response time is the time required for the display to transition from white to black(Rise Time, Tr_R) and from black to white (Decay Time, Tr_D). For additional information see Appendix A.

5. Viewing angle is the angle at which the contrast ratio is greater than 10. The angles are determined for the horizontal or x axis and the vertical or y axis with respect to the z axis which is normal to the LCD surface.

Product Specification

5. Interface Connections

Interface chip must be used LVDS, part No. DS90CF383MTD made by National Semiconductor. Or used the compatible interface chips(TI,Thine).
This LCD employs six interface connections, a 21 pin connector is used for the module electronics, a five pin connector is used for the module power(+12V), and four connector, a two pin connector, is used for the integral backlight system.

The electronics interface connector is a model FI-WE21PB-VF manufactured by JAE. The pin configuration for the connector is shown in the table 3.

Table 3 MODULE CONNECTOR PIN CONFIGURATION(for the LVDS signal)

Pin	Symbol	Description	Notes
1	FR3P	Plus Signal of Odd Channel 3 (LVDS)	O3P
2	FR3M	Minus Signal of Odd Channel 3 (LVDS)	O3M
3	FCLKINP	Plus Signal of Odd Clock Channel (LVDS)	OCKP
4	FCLKINM	Minus Signal of Odd Clock Channel (LVDS)	OCKM
5	FR2P	Plus Signal of Odd Channel 2 (LVDS)	O2P
6	FR2M	Minus Signal of Odd Channel 2 (LVDS)	O2M
7	FR1P	Plus Signal of Odd Channel 1 (LVDS)	O1P
8	FR1M	Minus Signal of Odd Channel 1 (LVDS)	O1M
9	FR0P	Plus Signal of Odd Channel 0 (LVDS)	O0P
10	FR0M	Minus Signal of Odd Channel 0 (LVDS)	O0M
11	SR3P	Plus Signal of Even Channel 3 (LVDS)	E3P
12	SR3M	Minus Signal of Even Channel 3 (LVDS)	E3M
13	SCLKINP	Plus Signal of Even Clock Channel (LVDS)	ECKP
14	SCLKINM	Minus Signal of Even Clock Channel (LVDS)	ECKM
15	SR2P	Plus Signal of Even Channel 2 (LVDS)	E2P
16	SR2M	Minus Signal of Even Channel 2 (LVDS)	E2M
17	SR1P	Plus Signal of Even Channel 1 (LVDS)	E1P
18	SR1M	Minus Signal of Even Channel 1 (LVDS)	E1M
19	SR0P	Plus Signal of Even Channel 0 (LVDS)	E0P
20	SR0M	Minus Signal of Even Channel 0 (LVDS)	E0M
21	NC	Not Connect	NC

The module power connector is a model B5B-ZR-SM3-IF manufactured by JST. The pin configuration for the connector is shown in the table 4.

Table 4 POWER CONNECTOR PIN CONFIGURATION

Pin	Symbol	Description	Notes
1	GND	Ground	1
2	GND	Ground	2
3	NC	Not Connect	
4	IV _{AA}	Supply voltage for LCD module	
5	IV _{AA}	Supply voltage for LCD module	

Notes: 1. All GND(ground) pins should be connected together and to Vss which should also be connected to the LCD's metal frame.
2. All IV_{AA}(power input) pins should be connected together.

The backlight interface connector is a model BHSR-02VS-1, manufactured by JST. The mating connector part number is SM02B-BHsS-1 or equivalent. The pin configuration for the connector is shown in the table 5.

Table 4 BACKLIGHT CONNECTOR PIN CONFIGURATION

Pin	Symbol	Description	Notes
1	HV	Lamp power input	1
2	LV	Ground	2

Notes: 1. The input power terminal is colored pink. Ground pin color is white.
2. The backlight ground should be common with Vss.

6. Signal Timing Specification(Between PanelLink & Timing Controller)

Parameter	Symbol	Value			Units	Notes
		Min.	Typ.	Max.		



Product Specification

Main Clock	Frequency	$f_{CLK}(=1/t_{CLK})$	54	54	54	MHz	Dclk : 108MHz
	High duration	t_{wCH}	$0.4 t_{CLK}$	$0.5 t_{CLK}$	$0.6 t_{CLK}$	ns	
	Low duration	t_{wCL}	$0.4 t_{CLK}$	$0.5 t_{CLK}$	$0.6 t_{CLK}$	ns	
	Rise Time	t_{rCLK}	-	-	2.3	ns	
Data	Fall Time	t_{fCLK}	-	-	1.4	ns	for f_{CLK} for f_{CLK} $C_L = 15pF$ $C_L = 15pF$
	Set-up duration	t_{SD}	5.0	-	-	ns	
	Hold duration	t_{HD}	5.0	-	-	ns	
	Rise Time	t_{Dr}	-	-	4.5	ns	
Hsync	Fall Time	t_{Df}	-	-	2.1	ns	
	Period	t_{HP}	12.6	15.63	-	clock clock ns	
	Pulse Width	t_{WH}	680	844	-		
Rise/Fall Time	t_{Hr}, t_{Hf}	8	56	-	5		
Vsync	Period	t_{VP}	1032	16.661	-	msec	lines lines ns
	Pulse Width	t_{WV}	2	3	-		
	Rise/Fall Time	t_{Vr}, t_{Vf}	-	-	10		
Data Enable	Set-up duration	t_{SI}	5	-	-	ns	for f_{CLK} for f_{CLK}
	Hold duration	t_{HI}	5	-	-	ns	
	Horizontal Back Porch	t_{HBP}	8	124	-	clock	
	Horizontal Active		640	640	-	clock	
	Horizontal Front porch	t_{HFP}	8	24	-	clock	
	Vertical Back Porch	t_{VBP}	1	38	-	lines	
	Vertical Active		1024	1024	-	lines	
	Vertical Front porch	t_{VFP}	1	1	-	lines	
Rise/Fall Time	t_{Ir}, t_{If}	-	-	5	ns		
Hsync- Clock phase difference		t_{HC}	$t_{CLK}-10$	-	t_{wCL}	ns	
Hsync-Vsync phase difference		t_{HV}	-	-	$t_{HP}-t_{WH}$	ns	

Product Specification

7. Signal Timing Wave forms

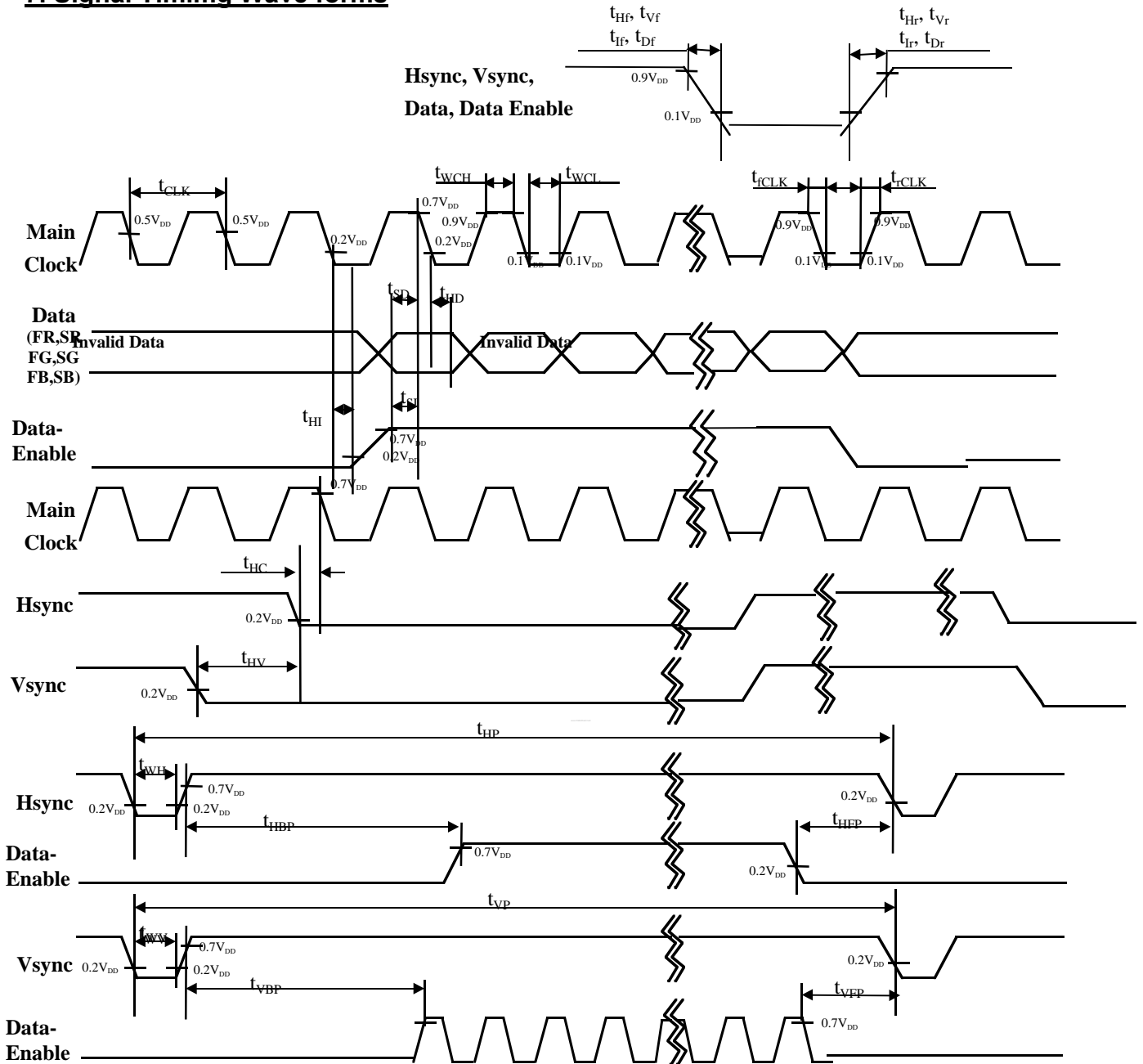

Product Specification
8. Color Input Data Reference

The brightness of each primary color (red, green and blue) is based on the 8-bit gray scale data input for the color; the higher the binary input, the brighter the color. The table below provides a reference for color versus data input.

Table 5 COLOR DATA REFERENCE

Color		Input Color Data																							
		Red								Green								Blue							
		MSB				LSB				MSB				LSB				MSB				LSB			
R	R	R	R	R	R	R	R	G	G	G	G	G	G	G	G	B	B	B	B	B	B	B	B		
7	6	5	4	3	2	1	0	7	6	5	4	3	2	1	0	7	6	5	4	3	2	1	0		
Basic Colors	Black	0	0	0	0	0	0	0	0	0	0	0	0	0	0	0	0	0	0	0	0	0	0	0	
	Red(255)	1	1	1	1	1	1	1	1	0	0	0	0	0	0	0	0	0	0	0	0	0	0	0	
	Green(255)	0	0	0	0	0	0	0	0	1	1	1	1	1	1	1	1	0	0	0	0	0	0	0	
	Blue(255)	0	0	0	0	0	0	0	0	0	0	0	0	0	0	0	0	1	1	1	1	1	1	1	
	Cyan	0	0	0	0	0	0	0	0	1	1	1	1	1	1	1	1	1	1	1	1	1	1	1	
	Magenta	1	1	1	1	1	1	1	1	0	0	0	0	0	0	0	0	1	1	1	1	1	1	1	
	Yellow	1	1	1	1	1	1	1	1	1	1	1	1	1	1	1	1	0	0	0	0	0	0	0	
	White	1	1	1	1	1	1	1	1	1	1	1	1	1	1	1	1	1	1	1	1	1	1	1	
Red	Red(000) Dark	0	0	0	0	0	0	0	0	0	0	0	0	0	0	0	0	0	0	0	0	0	0		
	Red(001)	0	0	0	0	0	0	0	1	0	0	0	0	0	0	0	0	0	0	0	0	0	0		
	Red(002)	0	0	0	0	0	0	1	0	0	0	0	0	0	0	0	0	0	0	0	0	0	0		
	:	:	:	:	:	:	:	:	:	:	:	:	:	:	:	:	:	:	:	:	:	:	:		
	Red(253)	1	1	1	1	1	1	0	1	0	0	0	0	0	0	0	0	0	0	0	0	0	0		
	Red(254)	1	1	1	1	1	1	1	0	0	0	0	0	0	0	0	0	0	0	0	0	0	0		
	Red(255) Bright	1	1	1	1	1	1	1	1	0	0	0	0	0	0	0	0	0	0	0	0	0	0		
Green	Green(000)Dark	0	0	0	0	0	0	0	0	0	0	0	0	0	0	0	0	0	0	0	0	0	0		
	Green(001)	0	0	0	0	0	0	0	0	0	0	0	0	0	0	0	1	0	0	0	0	0	0		
	Green(002)	0	0	0	0	0	0	0	0	0	0	0	0	0	0	1	0	0	0	0	0	0	0		
	:	:	:	:	:	:	:	:	:	:	:	:	:	:	:	:	:	:	:	:	:	:	:		
	Green(253)	0	0	0	0	0	0	0	0	1	1	1	1	1	1	0	1	0	0	0	0	0	0		
	Green(254)	0	0	0	0	0	0	0	0	1	1	1	1	1	1	1	0	0	0	0	0	0	0		
	Green(255)Bright	0	0	0	0	0	0	0	0	1	1	1	1	1	1	1	1	0	0	0	0	0	0		
Blue	Blue(000) Dark	0	0	0	0	0	0	0	0	0	0	0	0	0	0	0	0	0	0	0	0	0	0		
	Blue(001)	0	0	0	0	0	0	0	0	0	0	0	0	0	0	0	0	0	0	0	0	0	1		
	Blue(002)	0	0	0	0	0	0	0	0	0	0	0	0	0	0	0	0	0	0	0	0	0	1		
	:	:	:	:	:	:	:	:	:	:	:	:	:	:	:	:	:	:	:	:	:	:	:		
	Blue(253)	0	0	0	0	0	0	0	0	0	0	0	0	0	0	0	1	1	1	1	1	1	0		
	Blue(254)	0	0	0	0	0	0	0	0	0	0	0	0	0	0	0	1	1	1	1	1	1	0		
	Blue(255) Bright	0	0	0	0	0	0	0	0	0	0	0	0	0	0	0	1	1	1	1	1	1	1		

9. Power Sequence

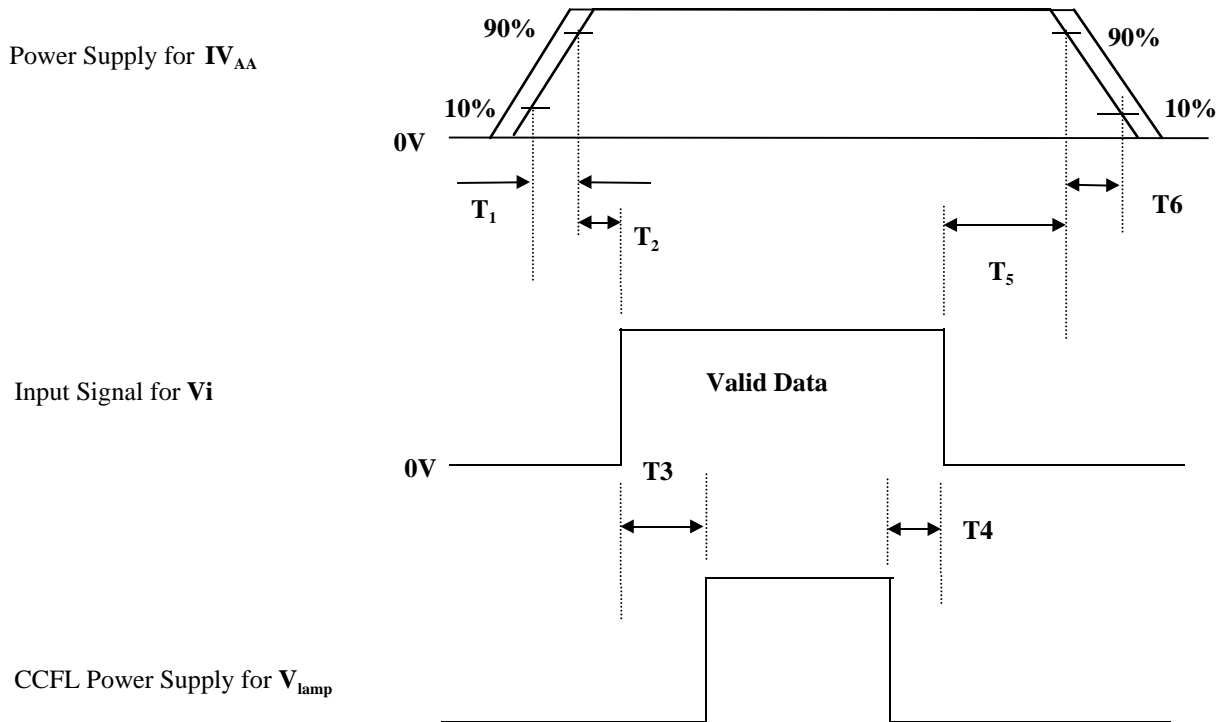

* Set 0 Volt < $V_i(t)$ < $IV_{AA}(t)$

Here $V_i(t)$, $IV_{AA}(t)$ indicate the transitive state of V_i , IV_{AA} when power supply is turned ON or OFF

* T_1, T_2, T_5, T_6 : 10 ns ~ 20 ms.

* T_3, T_4 : 100 ms ~ 200 ms.

Notes: 1. Please avoid floating state of interface signal at invalid period.

2. When the interface signal is invalid, be sure to pull down the power supply for LCD AV_{CC} to 0V.

3. BackLight Inverter power must be turn on after power supply for logic and interface signal are valid.

Product Specification

10. Mechanical Characteristics

The chart below provides general mechanical characteristics for the model LM181E1 LCD. In addition, the figure below is a detailed mechanical drawing of the LCD. Note that dimension are given for reference purposes only.

Outside dimensions:	Width	413.0mm(TYP.)
	Height	333.0mm(TYP.)
	Thickness	21.5mm(TYP.)
Active Display area	Width	359.040mm
	Height	287.232mm
Weight (approximate)		3000 gram (Max.)

Product Specification

11. Reliability

No.	Test ITEM	Conditions
1	High temperature storage test	Ta = 60 240h
2	Low temperature storage test	Ta = -20 240h
3	High temperature operation test	Ta = 50 240h
4	Low temperature operation test	Ta = 0 240h
5	Altitude	Operating : 12,000ft Storage : 40,000ft
6	Drop	tbd. (at Packing)
7	Vibration test (non-operating)	1.5G(10~200Hz) Sine ±X, ±Y, ±Z, 20min one time each direction
8	Shock test (non-operating)	Shock level : 100G Waveform: half sine wave, 2ms Direction : ±X, ±Y, ±Z one time each direction
9	ESD test (non-operating)	Condition : 150 330 Terminal : 200V Chassis : 10

{Result Evaluation Criteria}

There should be no change which might affect the practical display function when the display quality test is conducted under normal operating condition.

12. PRECAUTIONS

Please pay attention to the followings when you use this TFT/LCD module with Back-light unit.

- 1) You must mount Module using mounting holes arranged in 4 corners.
- 2) Be sure to turn off the power when connecting or disconnecting the circuit.
- 3) Note that the polarizers are easily damaged. Pay attention not to scratch or press this surface with any hard object.
- 4) When the LCD surface become dirty, please wipe it off with a soft material.
(ie.cotton ball)
- 5) Protect the module from the ESD as it may damage the electronic circuit (C-MOS).
Make certain that treatment person's body are grounded through wrist bend.
- 6) Do not disassemble the module and be careful not to incur a mechanical shock that might occur during installation. It may cause permanent damage.
- 7) Do not leave the module in high temperatures, Particularly in areas of high humidity for a long time.
- 8) The module not be expose to the direct sunlight.
- 9) Avoid contact with water as it may a short circuit within the module.

Product Specification

A. APPENDIX

A-1 Brightness

<measuring point>

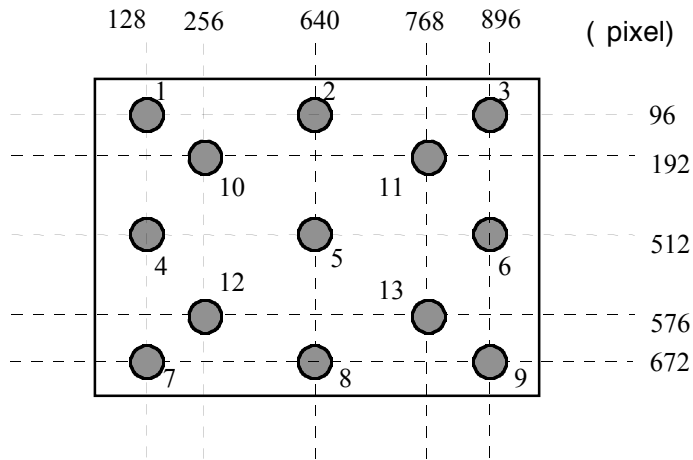

A-2 RESPONSE TIME

The response time is defined as the following figure and shall be measured by switching the input signal for "black" and "white".

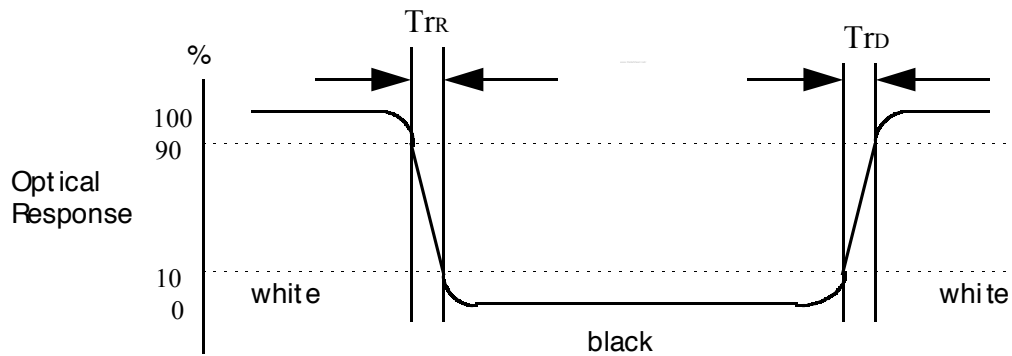

Product Specification

A-3 Viewing angle

<Definition of viewing angle range>

