

Product Specification

SPECIFICATION FOR APPROVAL

- () Preliminary Specification
 (◆) Final Specification

Title	20.0" HD+ TFT LCD
-------	-------------------

BUYER	Fujitsu
MODEL	

SUPPLIER	LG Display Co., Ltd.
*MODEL	LM200WD3
SUFFIX	TLF1

*When you obtain standard approval,
 please use the above model name without suffix

SIGNATURE	DATE
/	_____
/	_____
/	_____

Please return 1 copy for your confirmation
 With your signature and comments.

APPROVED BY	DATE
K.G. Park / G.Manager	_____
REVIEWED BY	
D.G. Kim / Manager [C]	_____
H.D. Joo / Manager [M]	_____
J.C. Lim / Manager [P]	_____
PREPARED BY	
S.J. Yeom / Engineer	_____

**Product Engineering Dept.
 LG Display Co., Ltd**

Product Specification
Contents

No	ITEM	Page
	COVER	1
	CONTENTS	2
	RECORD OF REVISIONS	3
1	GENERAL DESCRIPTION	4
2	ABSOLUTE MAXIMUM RATINGS	5
3	ELECTRICAL SPECIFICATIONS	6
	1) ELECTRICAL CHARACTERISTICS	6
	2) INTERFACE CONNECTIONS	8
	3) LVDS characteristics	11
	4) SIGNAL TIMING SPECIFICATIONS	14
	5) SIGNAL TIMING WAVEFORMS	15
	6) COLOR INPUT DATA REFERNECE	16
	7) POWER SEQUENCE	18
	8) POWER DIP CONDITION	19
4	OPTICAL SFECIFICATIONS	19
5	MECHANICAL CHARACTERISTICS	25
6	RELIABILITY	28
7	INTERNATIONAL STANDARDS	29
	1) SAFETY	29
	2) EMC	29
	3) ENVIRONMENT	29
8	PACKING	30
	1) DESIGNATION OF LOT MARK	30
	2) PACKING FORM	30
9	PRECAUTIONS	31
	1) MOUNTING PRECAUTIONS	31
	2) OPERATING PRECAUTIONS	31
	3) ELECTROSTATIC DISCHARGE CONTROL	32
	4) PRECAUTIONS FOR STRONG LIGHT EXPOSURE	32
	5) STROAGE	32
	6) HANDLING PRECAUTIONS FOR PROTECTION FILM	32

Product Specification
Record of revisions

Revision No	Date	Page	Description
Ver.0.1	Nov.,08,2011		Preliminary Specifications.
Ver.0.2	Jan.,11,2012	6 19	Update Electrical characteristics. Update color coordinates spec
Ver.1.0	Feb.,02,2012		Final Specifications.

Product Specification

1. General description

LM200WD3-TLF1 is a Color Active Matrix Liquid Crystal Display with an integral Light Emitting Diode(LED) backlight system. The matrix employs a-Si Thin Film Transistor as the active element. It is a transmissive type display operating in the normally white mode. It has a 20.0 inch diagonally measured active display area with HD+ resolution (900 vertical by 1600 horizontal pixel array) Each pixel is divided into Red, Green and Blue sub-pixels or dots which are arranged in vertical stripes. Gray scale or the brightness of the sub-pixel color is determined with a 8-bit gray scale signal for each dot, thus, presenting a palette of more than 16.7M colors with Advanced-FRC(Frame Rate Control). It has been designed to apply the interface method that enables low power, high speed, low EMI. FPD Link or compatible must be used as a LVDS(Low Voltage Differential Signaling) chip. It is intended to support applications where thin thickness, wide viewing angle, low power are critical factors and graphic displays are important. In combination with the vertical arrangement of the sub-pixels, the LM200WD3-TLF1 characteristics provide an excellent flat panel display for office automation products such as monitors.

FIG. 1 Block diagram

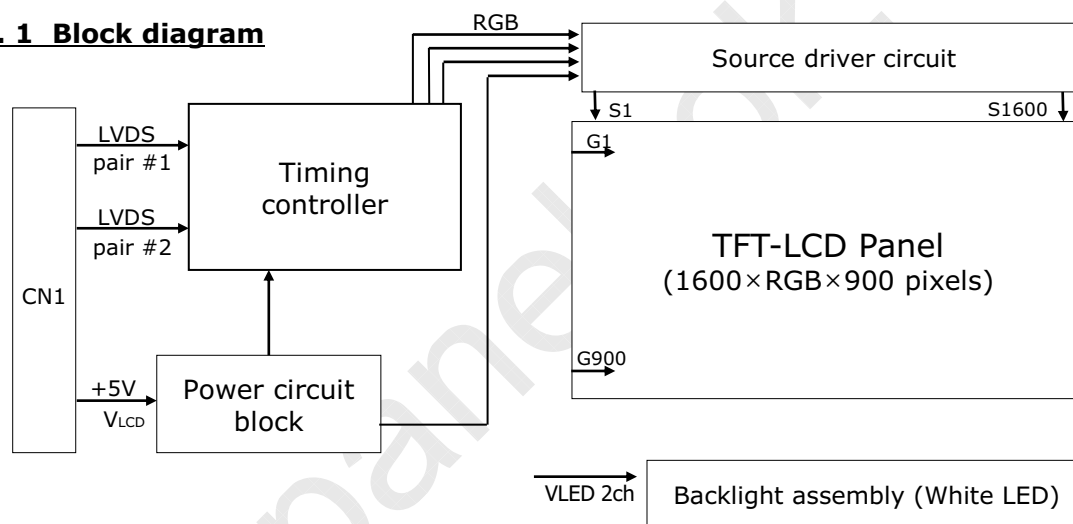

General features

Active screen size	20.0 inches (508.05mm) diagonal
Outline Dimension	462.8(H) x 272.0(V) x 10.2(D) mm(Typ.)
Pixel Pitch	0.09225*RGB(H)mm x 0.27675(V)mm
Pixel Format	1600 horizontal By 900 vertical Pixels. RGB stripe arrangement
Interface	LVDS 2Port
Color depth	16.7M colors
Luminance, white	250 cd/m ² (Center 1Point, typ)
Viewing Angle (CR>10)	R/L 170(Typ.), U/D 160(Typ.)
Power Consumption	Total 12.8 W(Typ.), (3.0 W@V _{LCD} , 9.8 W@I _{BL} = 120 mA)
Weight	1,490 g (Typ.)
Display operating mode	Transmissive mode, normally White
Surface treatments	Hard coating (3H), Anti-glare treatment of the front polarizer

Product Specification

2. Absolute maximum ratings

The following are maximum values which, if exceeded, may cause faulty operation or damage to the unit.

Table 1. Absolute maximum ratings

Parameter	Symbol	Values		Units	Notes
		Min	Max		
Power Supply Input Voltage	V_{LCD}	-0.3	+6.0	Vdc	At 25°C
Operating Temperature	T_{OP}	0	50	°C	1,2,3
Storage Temperature	T_{ST}	-20	60	°C	
Operating Ambient Humidity	H_{OP}	10	90	%RH	
Storage Humidity	H_{ST}	10	90	%RH	
LCM Surface Temperature (Operation)	$T_{Surface}$	0	65	°C	1, 4

Note : 1. Temperature and relative humidity range are shown in the figure below.

Wet bulb temperature should be 39 °C Max, and no condensation of water.

2. Maximum Storage Humidity is up to 40°C, 90% RH only for 4 corner light leakage Mura.

3. Storage condition is guaranteed under packing condition.

4. LCM Surface Temperature should be Min. 0°C and Max. 65°C under the VLCD=5.0V, fV=60Hz, 25°C ambient Temp. no humidity control and LED string current is typical value.

FIG. 2 Temperature and relative humidity

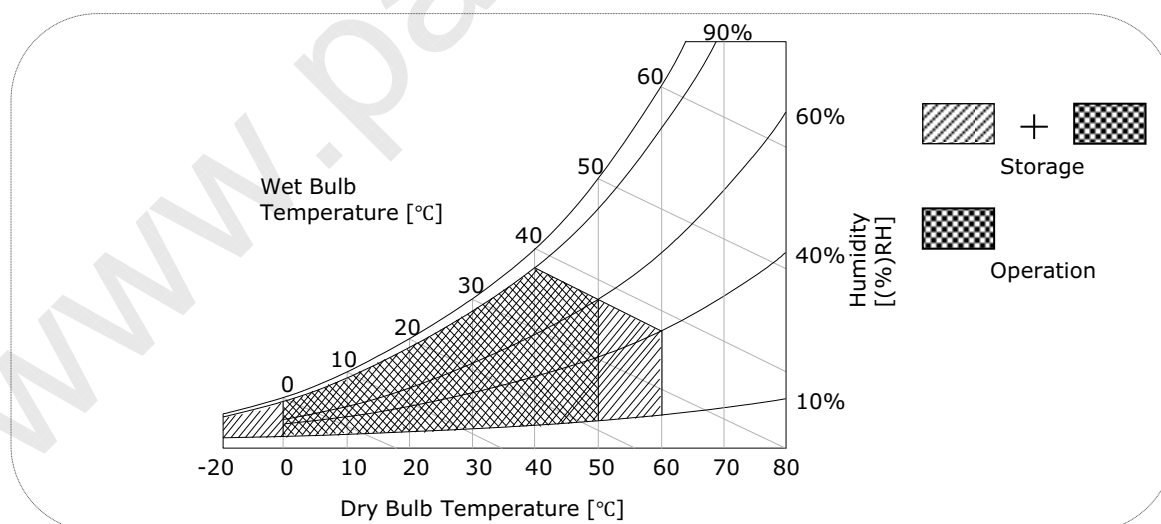

Product Specification
3. Electrical specifications
3-1. Electrical characteristics

It requires two power inputs. One is employed to power the LCD electronics and to drive the TFT array and liquid crystal. The second input power for the LED/Backlight, is typically generated by an LED Driver. The LED driver is an external unit to the LCDs.

Table 2. Electrical characteristics

Parameter	Symbol	Values			Unit	Notes
		Min	Typ	Max		
MODULE :						
Power Supply Input Voltage	V_{LCD}	4.5	5.0	5.5	Vdc	
Permissive Power Input Ripple	V_{LCD}	-	-	0.4	V	2
Power Supply Input Current	$I_{LCD-MOSAIC}$	-	600	750	mA	1,3
	$I_{LCD-BLACK}$	-	700	875	mA	1,4
	$I_{LCD-L80}$	-	570	715	mA	1
Power Consumption	P_{LCD}	-	3.0	3.8	Watt	1,3
Inrush current	I_{RUSH}	-	-	3	A	1,5

Note :

- The specified characteristics perform under the $V_{LCD}=5.0V$, $25 \pm 2^{\circ}C$, $f_v=60Hz$ condition.
 f_v is the frame frequency.
- Permissive Power Ripple should be measured under $V_{LCD}=5.0V$, $25 \pm 2^{\circ}C$,
 $f_v=75Hz$ condition and At that time,
we recommend the bandwidth configuration of oscilloscope is to be under 20MHz. (See FIG.3)
- Mosaic pattern(8 x 6) is displayed.
- Input current is specified at the maximum current pattern.
- The duration of Inrush current is about 5ms and rising time of power Input is $500us \pm 20\%$.

FIG.3 pattern for Electrical characteristics
power consumption
power input ripple
Energy star 5.0

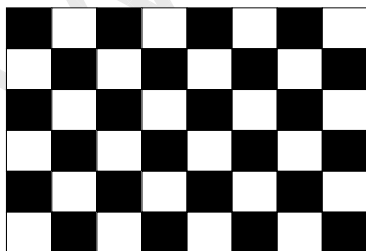
 White : 255Gray
 Black : 0Gray

Mosaic Pattern(8 x 6)

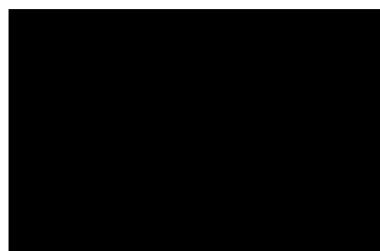

Full Black Pattern

 White : 255Gray (80%)
 Black : 0Gray (20%)

L80 Pattern

Product Specification
Table 3. LED array ELECTRICAL CHARACTERISTICS

Parameter	Symbol	Condition	Values			Unit	Notes
			Min.	Typ.	Max.		
LED String Current	Is		-	120	125	mA	1,2,5
LED String Voltage	Vs		38.4	41.0	43.6	V	1,5
Power Consumption	PBar		-	9.8	10.5	Watt	1,2,4
LED Life Time	LED_LT		30,000	-	-	Hrs	3

Notes) The LED Bar consists of 26 LED packages, 2 strings (parallel) x 13 packages (serial)

LED driver design guide

: The design of the LED driver must have specifications for the LED in LCD Assembly. The performance of the LED in LCM, for example life time or brightness, is extremely influenced by the characteristics of the LED driver.

So all the parameters of an LED driver should be carefully designed and output current should be Constant current control.

Please control feedback current of each string individually to compensate the current variation among the strings of LEDs.

When you design or order the LED driver, please make sure unwanted lighting caused by the mismatch of the LED and the LED driver (no lighting, flicker, etc) never occurs.

When you confirm it, the LCD module should be operated in the same condition as installed in your instrument.

Notes :

1. The specified values are for a single LED bar.
2. The specified current is defined as the input current for a single LED string with 100% duty cycle.
3. The LED life time is defined as the time when brightness of LED packages become 50% or less than the initial value under the conditions at $T_a = 25 \pm 2^\circ\text{C}$ and LED string current is typical value.
4. The power consumption shown above does not include loss of external driver.
 The typical power consumption is calculated as $P_{\text{Bar}} = V_s(\text{Typ.}) \times I_s(\text{Typ.}) \times \text{No. of strings}$.
 The maximum power consumption is calculated as $P_{\text{Bar}} = V_s(\text{Max.}) \times I_s(\text{Typ.}) \times \text{No. of strings}$.
5. LED operating conditions must not exceed Max. ratings.

Product Specification
3-2. Interface connections
3-2-1. LCD Module

LCD connector(CN1) : GT103-30S-HF15-E2500 (LSM) , UJU(IS100-L300-C23)

Mating connector : FI-X30H and FI-X30HL (JAE) or Equivalent

Table 4. Module connector(CN1) pin configuration

Pin No	Symbol	Description
1	RX00-	Minus signal of 1st channel 0 (LVDS)
2	RX00+	Plus signal of 1st channel 0 (LVDS)
3	RX01-	Minus signal of 1st channel 1 (LVDS)
4	RX01+	Plus signal of 1st channel 1 (LVDS)
5	RX02-	Minus signal of 1st channel 2 (LVDS)
6	RX02+	Plus signal of 1st channel 2 (LVDS)
7	GND	Ground(AGP)
8	RXOC-	Minus signal of 1st clock channel (LVDS)
9	RXOC+	Plus signal of 1st clock channel (LVDS)
10	RX03-	Minus signal of 1st channel 3 (LVDS)
11	RX03+	Plus signal of 1st channel 3 (LVDS)
12	RXE0-	Minus signal of 2nd channel 0 (LVDS)
13	RXE0+	Plus signal of 2nd channel 0 (LVDS)
14	GND	Ground
15	RXE1-	Minus signal of 2nd channel 1 (LVDS)
16	RXE1+	Plus signal of 2nd channel 1 (LVDS)
17	GND	Ground
18	RXE2-	Minus signal of 2nd channel 2 (LVDS)
19	RXE2+	Plus signal of 2nd channel 2 (LVDS)
20	RXEC-	Minus signal of 2nd clock channel (LVDS)
21	RXEC+	Plus signal of 2nd clock channel (LVDS)
22	RXE3-	Minus signal of 2nd channel 3 (LVDS)
23	RXE3+	Plus signal of 2nd channel 3 (LVDS)
24	GND	Ground
25	NC	No Connection (For LCD internal use only.)
26	NC	No Connection (For LCD internal use only.)
27	PWM_OUT	Reference signal for inverter control
28	VLCD	Power Supply (5.0V)
29	VLCD	Power Supply (5.0V)
30	VLCD	Power Supply (5.0V)

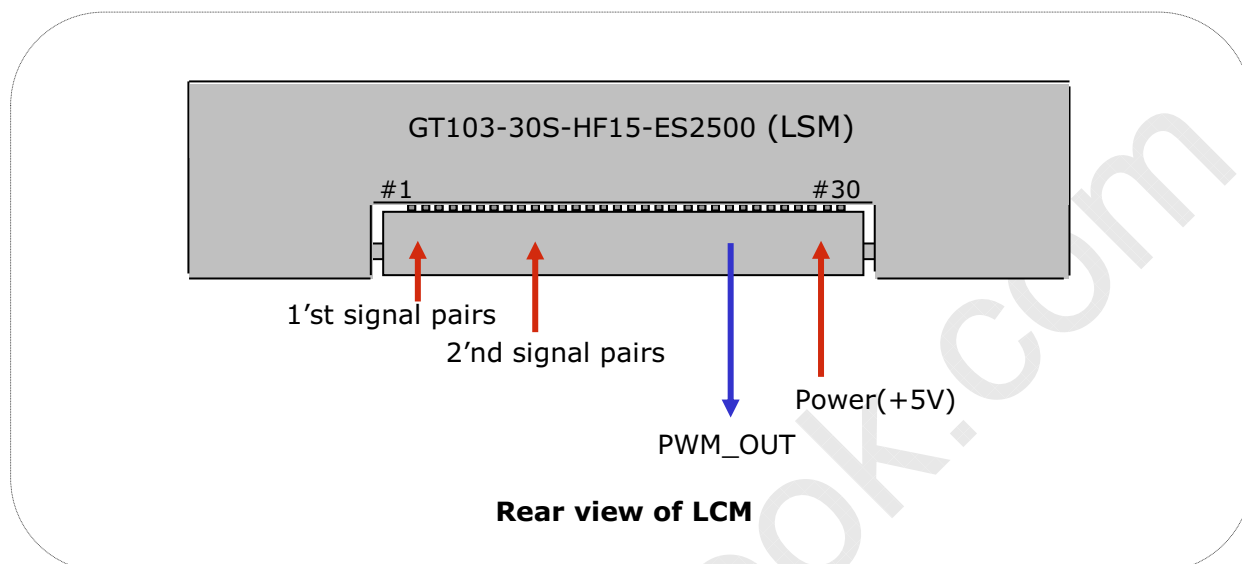
Product Specification
FIG. 4 Connector diagram

Note:

1. NC: No Connection.
2. All GND(ground) pins should be connected together and to Vss which should also be connected to the LCD's metal frame.
3. All V_{LCD} (power input) pins should be connected together.
4. Input Level of LVDS signal is based on the IEA 664 Standard.
5. PWM_OUT is a reference signal for inverter control.
 This PWM signal is synchronized with vertical frequency.
 Its frequency is 3 times of vertical frequency, and its duty ratio is 50%.
 If the system don't use this pin, do not connect.

Product Specification
3-2-2. LED Interface

The LED interface connector is a model SM06B-SHJH(HF) manufactured by JST.
 The mating connector is a SHJP-06V-S(HF) or Equivalent.
 The pin configuration for the connector is shown in the table below.

Table 5. LED connector pin configuration

Pin	Symbol	Description	Notes
1	FB1	Channel1 Current Feedback	
2	NC	No connection	
3	VLED	LED Power Supply	
4	VLED	LED Power Supply	
5	NC	No connection	
6	FB2	Channel2 Current Feedback	

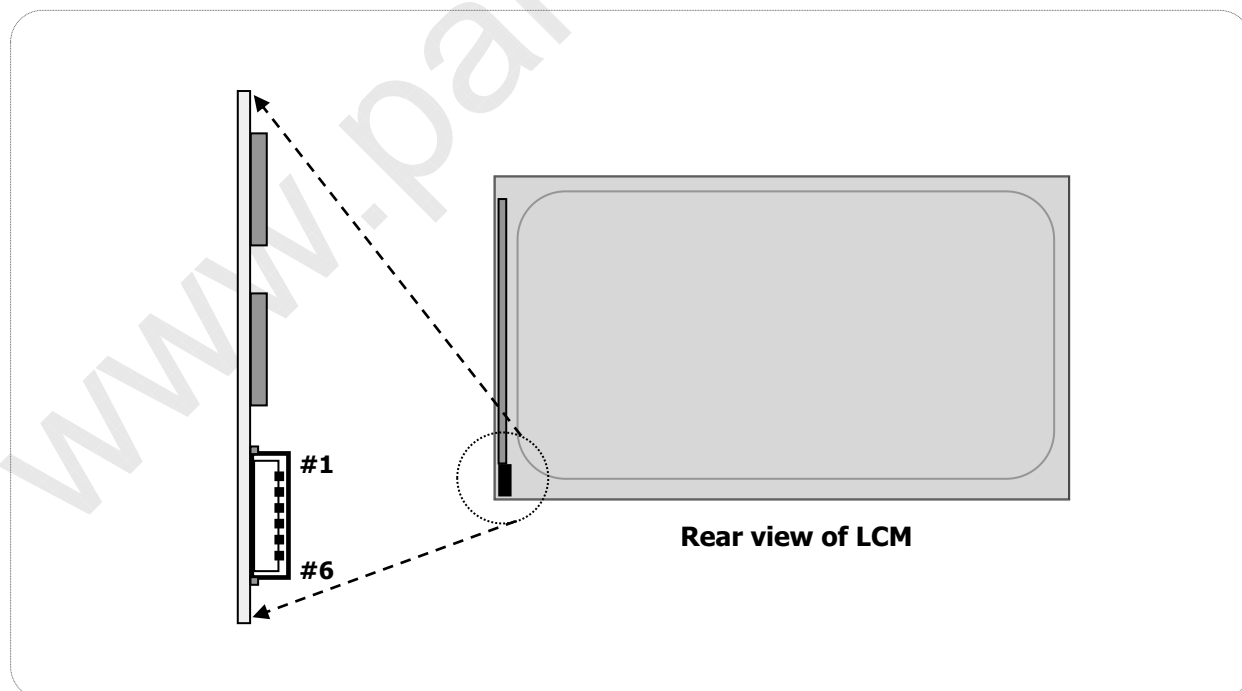
FIG. 5 Backlight connector view

Product Specification

3-3. LVDS characteristics

3-3-1. LVDS Data format

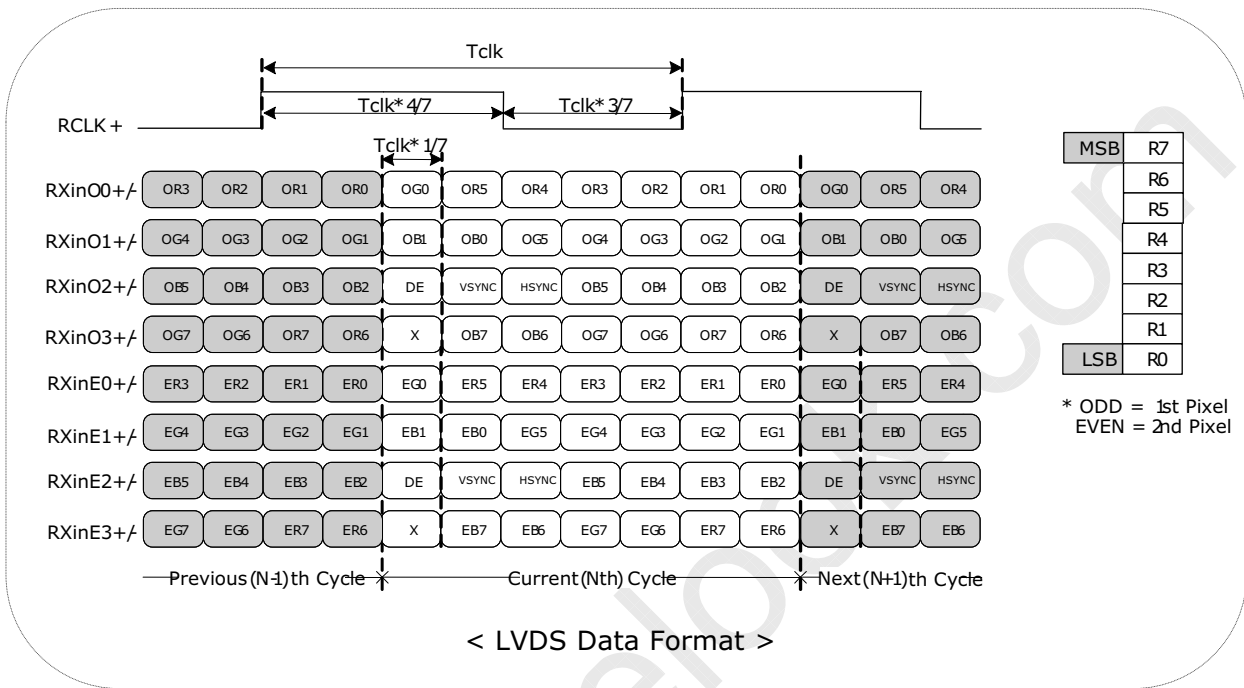

3-3-2. DC Specification

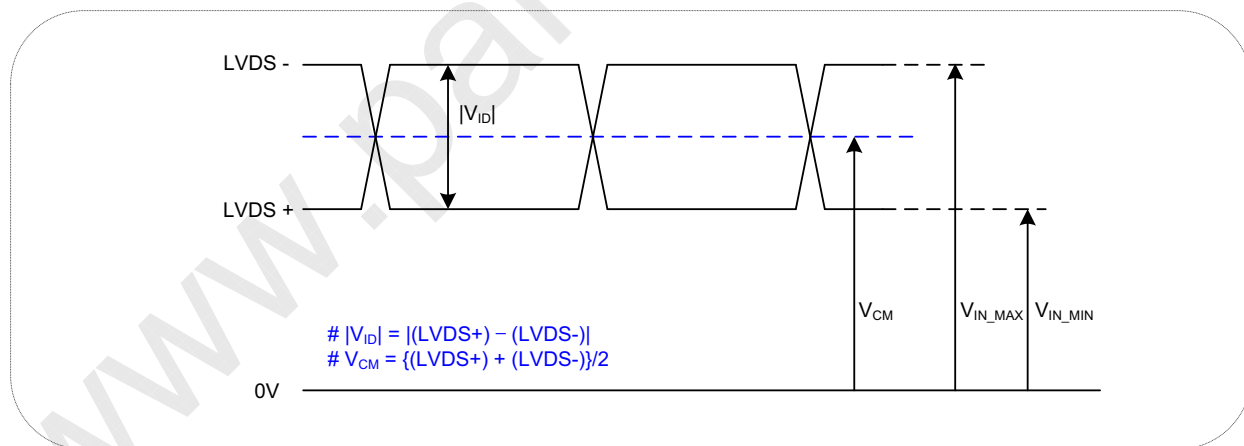

Description	Symbol	Min	Max	Unit	Notes
LVDS Differential Voltage	V _{ID}	200	600	mV	-
LVDS Common mode Voltage	V _{CM}	0.6	1.5	V	-
LVDS Input Voltage Range	V _{IN}	0.3	1.8	V	-

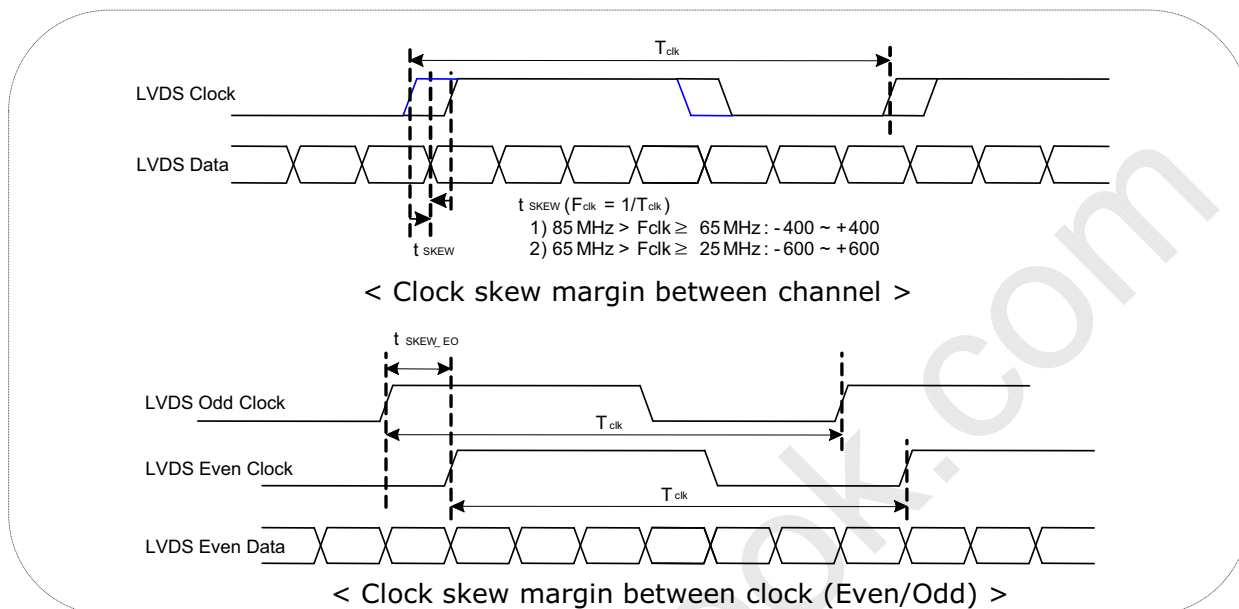
Product Specification
3-3-3. AC Specification

Description	Symbol	Min	Max	Unit	Notes
LVDS Clock to Data Skew Margin	t_{SKEW}	- 400	+ 400	ps	$85\text{MHz} > F_{clk} \geq 65\text{MHz}$
	t_{SKEW}	- 600	+ 600	ps	$65\text{MHz} > F_{clk} \geq 25\text{MHz}$
Maximum deviation of input clock frequency during SSC	F_{DEV}	-	± 3	%	1
LVDS Clock to Clock Skew Margin (Even to Odd)	t_{SKEW_EO}	- 1/7	+ 1/7	T_{clk}	-

Note 1 :

This SSC specifications are just T-CON operation specification. In case of various system condition, the optimum setting value of SSC can be different. LGD recommend the SI should be adjust the SSC deviation and modulation frequency in order not to happen any kinds of defect phenomenon.

Product Specification
Table 6. Required signal assignment for Flat Link(NS:DS90CF383) transmitter

Pin #	Pin Name	Require Signal	Pin #	Pin Name	Require Signal
1	VCC	Power Supply for TTL Input	29	GND	Ground pin for TTL
2	D5	TTL Input (R7)	30	D26	TTL Input (DE)
3	D6	TTL Input (R5)	31	T _x CLKIN	TTL Level clock Input
4	D7	TTL Input (G0)	32	PWR DWN	Power Down Input
5	GND	Ground pin for TTL	33	PLL GND	Ground pin for PLL
6	D8	TTL Input (G1)	34	PLL VCC	Power Supply for PLL
7	D9	TTL Input (G2)	35	PLL GND	Ground pin for PLL
8	D10	TTL Input (G6)	36	LVDS GND	Ground pin for LVDS
9	VCC	Power Supply for TTL Input	37	T _x OUT3 +	Positive LVDS differential data output 3
10	D11	TTL Input (G7)	38	T _x OUT3 -	Negative LVDS differential data output 3
11	D12	TTL Input (G3)	39	T _x CLKOUT +	Positive LVDS differential clock output
12	D13	TTL Input (G4)	40	T _x CLKOUT -	Negative LVDS differential clock output
13	GND	Ground pin for TTL	41	T _x OUT2 +	Positive LVDS differential data output 2
14	D14	TTL Input (G5)	42	T _x OUT2 -	Negative LVDS differential data output 2
15	D15	TTL Input (B0)	43	LVDS GND	Ground pin for LVDS
16	D16	TTL Input (B6)	44	LVDS VCC	Power Supply for LVDS
17	VCC	Power Supply for TTL Input	45	T _x OUT1 +	Positive LVDS differential data output 1
18	D17	TTL Input (B7)	46	T _x OUT1 -	Negative LVDS differential data output 1
19	D18	TTL Input (B1)	47	T _x OUT0 +	Positive LVDS differential data output 0
20	D19	TTL Input (B2)	48	T _x OUT0 -	Negative LVDS differential data output 0
21	GND	Ground pin for TTL Input	49	LVDS GND	Ground pin for LVDS
22	D20	TTL Input (B3)	50	D27	TTL Input (R6)
23	D21	TTL Input (B4)	51	D0	TTL Input (R0)
24	D22	TTL Input (B5)	52	D1	TTL Input (R1)
25	D23	TTL Input (RSVD)	53	GND	Ground pin for TTL
26	VCC	Power Supply for TTL Input	54	D2	TTL Input (R2)
27	D24	TTL Input (HSYNC)	55	D3	TTL Input (R3)
28	D25	TTL Input (VSYNC)	56	D4	TTL Input (R4)

Notes : Refer to LVDS Transmitter Data Sheet for detail descriptions.

Product Specification
3-4. Signal timing specifications

This is the signal timing required at the input of the User connector. All of the interface signal timing should be satisfied with the following specifications for it's proper operation.

Table 7. Timing table

Parameter		Symbol	Min.	Typ.	Max.	Unit	Notes
D _{CLK}	Period	t _{CLK}	14.6	18.5	23.1	ns	Pixel frequency : Typ.108.0MHz
	Frequency	f _{CLK}	43.2	54.0	68.4	MHz	
Horizontal	Horizontal Valid	t _{HV}	800	800	800	t _{CLK}	
	H Period Total	t _{HP}	856	900	1200		
	Hsync Frequency	f _H	48.0	60.0	76.0		
Vertical	Vertical Valid	t _{VV}	900	900	900	t _{HP}	
	V Period Total	t _{VP}	908	1000	1300		
	Vsync Frequency	f _V	48	60	76		

Note:

1. DE Only mode operation. The input of Hsync & Vsync signal does not have an effect on LCD normal operation.
2. The performance of the electro-optical characteristics may be influenced by variance of the vertical refresh rates.
3. Horizontal period should be even.
4. Hsync Period, Hsync Width, and Horizontal Back Porch should be any times of of character number(4).

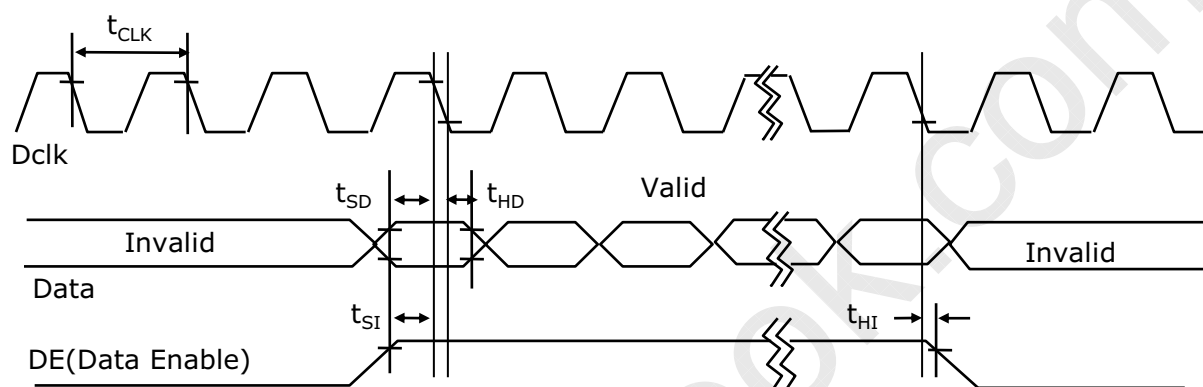
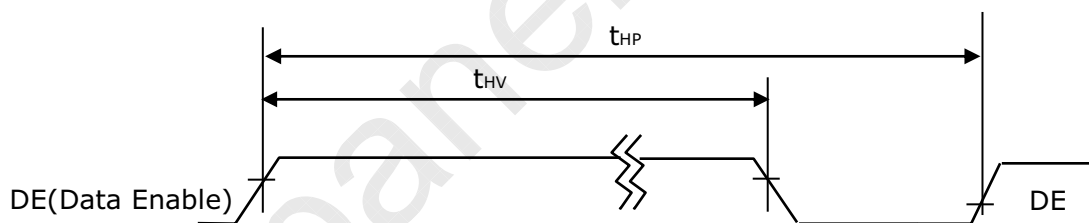
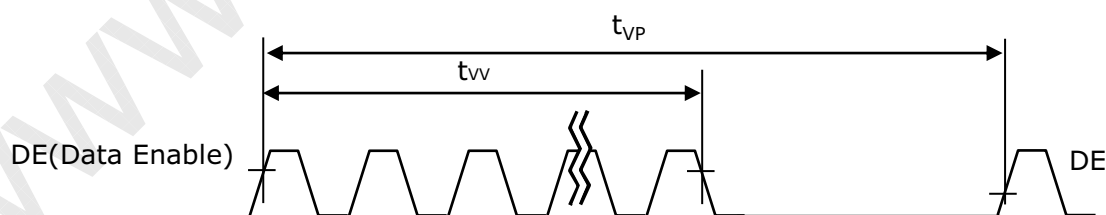
Product Specification
3-5. Signal timing waveforms
1. Dclk, DE, DATA waveforms

2. Horizontal waveform

3. Vertical waveform

Product Specification
3-6. Color input data reference

The brightness of each primary color (red, green and blue) is based on the 8bit gray scale data input for the color, the higher the binary input, the brighter the color. The table below provides a reference for color versus data input.

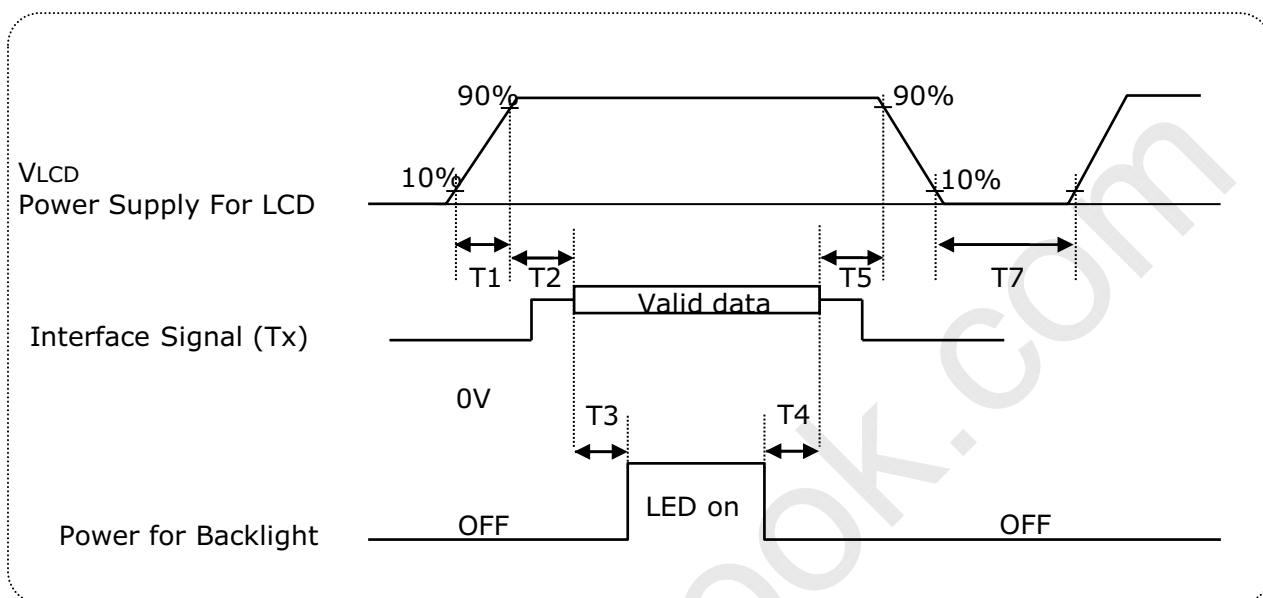
Table 8. Color data reference

Color		Input Color Data																							
		Red								Green								Blue							
		MSB				LSB				MSB				LSB				MSB				LSB			
		R7	R6	R5	R4	R3	R2	R1	R0	G7	G6	G5	G4	G3	G2	G1	G0	B7	B6	B5	B4	B3	B2	B1	B0
Basic Color	Black	0	0	0	0	0	0	0	0	0	0	0	0	0	0	0	0	0	0	0	0	0	0	0	0
	Red (255)	1	1	1	1	1	1	1	1	0	0	0	0	0	0	0	0	0	0	0	0	0	0	0	0
	Green (255)	0	0	0	0	0	0	0	0	1	1	1	1	1	1	1	1	0	0	0	0	0	0	0	0
	Blue (255)	0	0	0	0	0	0	0	0	0	0	0	0	0	0	0	0	1	1	1	1	1	1	1	1
	Cyan	0	0	0	0	0	0	0	0	1	1	1	1	1	1	1	1	1	1	1	1	1	1	1	1
	Magenta	1	1	1	1	1	1	1	1	0	0	0	0	0	0	0	0	1	1	1	1	1	1	1	1
	Yellow	1	1	1	1	1	1	1	1	1	1	1	1	1	1	1	1	0	0	0	0	0	0	0	0
	White	1	1	1	1	1	1	1	1	1	1	1	1	1	1	1	1	1	1	1	1	1	1	1	1
Red	Red(000) Dark	0	0	0	0	0	0	0	0	0	0	0	0	0	0	0	0	0	0	0	0	0	0	0	0
	Red(001)	0	0	0	0	0	0	0	1	0	0	0	0	0	0	0	0	0	0	0	0	0	0	0	0
	Red(002)	0	0	0	0	0	0	1	0	0	0	0	0	0	0	0	0	0	0	0	0	0	0	0	0
	-----	-	-	-	-	-	-	-	-	-	-	-	-	-	-	-	-	-	-	-	-	-	-	-	-
	-----	-	-	-	-	-	-	-	-	-	-	-	-	-	-	-	-	-	-	-	-	-	-	-	-
	Red(253)	1	1	1	1	1	1	0	1	0	0	0	0	0	0	0	0	0	0	0	0	0	0	0	0
	Red(254)	1	1	1	1	1	1	1	0	0	0	0	0	0	0	0	0	0	0	0	0	0	0	0	0
	Red(255) Bright	1	1	1	1	1	1	1	1	0	0	0	0	0	0	0	0	0	0	0	0	0	0	0	0
Green	Green(000) Dark	0	0	0	0	0	0	0	0	0	0	0	0	0	0	0	0	0	0	0	0	0	0	0	0
	Green(001)	0	0	0	0	0	0	0	0	0	0	0	0	0	0	1	0	0	0	0	0	0	0	0	0
	Green(002)	0	0	0	0	0	0	0	0	0	0	0	0	0	0	1	0	0	0	0	0	0	0	0	0
	-----	-	-	-	-	-	-	-	-	-	-	-	-	-	-	-	-	-	-	-	-	-	-	-	-
	-----	-	-	-	-	-	-	-	-	-	-	-	-	-	-	-	-	-	-	-	-	-	-	-	-
	Green(253)	0	0	0	0	0	0	0	0	1	1	1	1	1	1	0	1	0	0	0	0	0	0	0	0
	Green(254)	0	0	0	0	0	0	0	0	1	1	1	1	1	1	1	0	0	0	0	0	0	0	0	0
	Green(255) Bright	0	0	0	0	0	0	0	0	1	1	1	1	1	1	1	1	0	0	0	0	0	0	0	0
Blue	Blue(000) Dark	0	0	0	0	0	0	0	0	0	0	0	0	0	0	0	0	0	0	0	0	0	0	0	0
	Blue(001)	0	0	0	0	0	0	0	0	0	0	0	0	0	0	0	0	0	0	0	0	0	0	0	1
	Blue(002)	0	0	0	0	0	0	0	0	0	0	0	0	0	0	0	0	0	0	0	0	0	0	1	0
	-----	-	-	-	-	-	-	-	-	-	-	-	-	-	-	-	-	-	-	-	-	-	-	-	-
	-----	-	-	-	-	-	-	-	-	-	-	-	-	-	-	-	-	-	-	-	-	-	-	-	-
	Blue(253)	0	0	0	0	0	0	0	0	0	0	0	0	0	0	0	1	1	1	1	1	1	1	0	1
	Blue(254)	0	0	0	0	0	0	0	0	0	0	0	0	0	0	0	1	1	1	1	1	1	1	1	0
	Blue(255) Bright	0	0	0	0	0	0	0	0	0	0	0	0	0	0	0	1	1	1	1	1	1	1	1	1

Product Specification
3-7. Power sequence

Table 9. Power sequence

Parameter	Values			Units
	Min	Typ	Max	
T1	0.5	-	10	ms
T2	0.01	-	50	ms
T3	500	-	-	ms
T4	200	-	-	ms
T5	0.01	-	50	ms
T7	1	-	-	s

Notes :

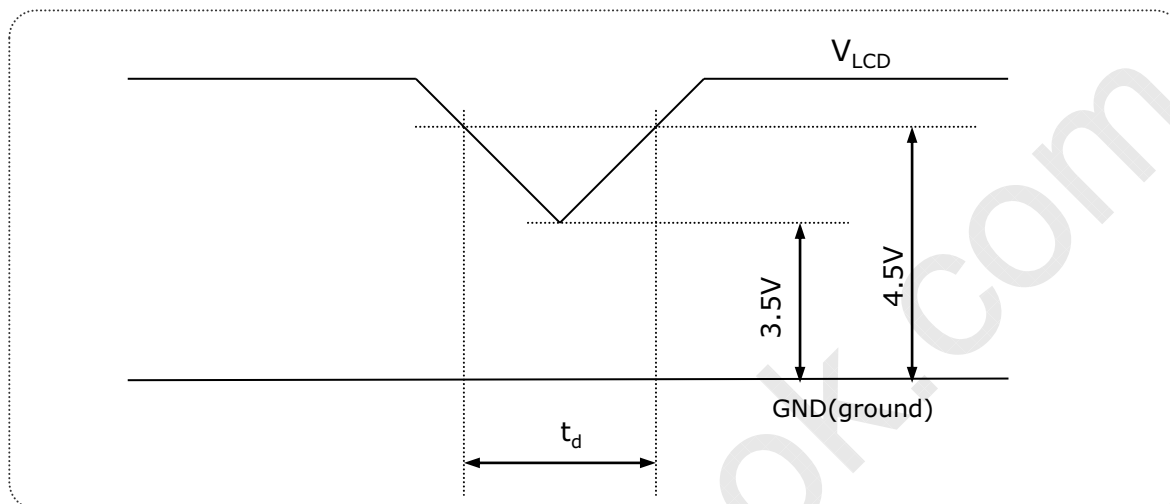
1. Please avoid floating state of interface signal at invalid period.
2. When the interface signal is invalid, be sure to pull down the power supply for LCD V_{LCD} to 0V.
3. LED power must be turn on after power supply for LCD an interface signal are valid.

Product Specification**3-8. V_{LCD} Power dip condition****FIG. 6 Power dip condition**

1) Dip condition

$$3.5V \leq V_{LCD} < 4.5V, t_d \leq 20ms$$

2) $V_{LCD} < 3.5V$

V_{LCD} -dip conditions should also follow the Power On/Off conditions for supply voltage.

Product Specification
4. Optical specification

Optical characteristics are determined after the unit has been 'ON' for 30 minutes in a dark environment at 25°C.

Table 10. Optical characteristics
 $T_a = 25^\circ\text{C}$, $V_{\text{LCD}} = 5.0\text{V}$, $f_v = 60\text{Hz}$, $f_{\text{CLK}} = 54.0\text{MHz}$, $I_{\text{BL}} = 120\text{mA}$

Parameter	Symbol	Values			Units	Notes	
		Min	Typ	Max			
Contrast Ratio	CR	700	1000	-		1 (PR-880)	
Surface Luminance, white	L_{WH}	200	250	-	cd/m ²	2 (PR-880)	
Luminance Variation	δ_{WHITE} 9P	75	-	-	%	3 (PR-880)	
Response Time	Rise Time	Tr_R	-	1.3	2.6	ms	4 (RD-80S)
	Decay Time	Tr_D	-	3.7	7.4	ms	
Color Gamut(1931)		67.5	72	-	%	(PR-650)	
Color Coordinates [CIE1931]	RED	R_x	Typ -0.03	0.642	Typ +0.03	(PR-650)	
		R_y		0.331			
	GREEN	G_x		0.310			
		G_y		0.618			
	BLUE	B_x		0.151			
		B_y		0.067			
	WHITE	W_x		0.313			
		W_y		0.329			
Viewing Angle (CR>5)						5 (PR-880)	
x axis, right($\phi=0^\circ$)	θ_r	75	88		Degree		
x axis, left ($\phi=180^\circ$)	θ_l	75	88				
y axis, up ($\phi=90^\circ$)	θ_u	70	85				
y axis, down ($\phi=270^\circ$)	θ_d	70	85				
Viewing Angle (CR>10)						6 (PR-880)	
x axis, right($\phi=0^\circ$)	θ_r	70	85		Degree		
x axis, left ($\phi=180^\circ$)	θ_l	70	85				
y axis, up ($\phi=90^\circ$)	θ_u	60	75				
y axis, down ($\phi=270^\circ$)	θ_d	70	85				
Crosstalk				1.5	%	7 (PR-880)	
Luminance uniformity - Angular dependence (TCO5.0)	LR	-	-	1.73		8 (PR-650)	
Color grayscale linearity	$\Delta u'v'$		0.018				

Product Specification

The values specified are at an approximate distance 50cm from the LCD surface at a viewing angle of ϕ and θ equal to 0° .

FIG. 7 presents additional information concerning the measurement equipment and method.

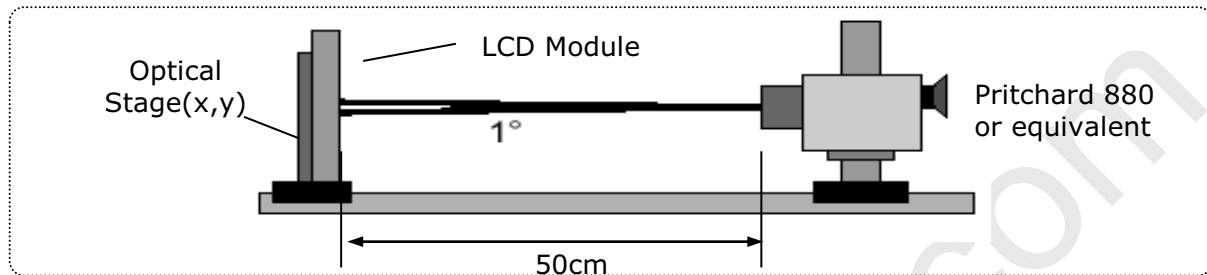
FIG. 7 Optical characteristic measurement equipment and method

Notes :

1. Contrast ratio(CR) is defined mathematically as :It is measured at center point(1)

$$\text{Contrast ratio} = \frac{\text{Surface luminance with all white pixels}}{\text{Surface luminance with all black pixels}}$$

2. Surface luminance is the luminance value at center 1 point(1) across the LCD surface 50cm from the surface with all pixels displaying white. For more information see FIG 8.

3. The variation in surface luminance , δ_{WHITE} is defined as

$$\delta_{\text{WHITE}} = \frac{\text{Minimum (P1,P2P9)}}{\text{Maximum (P1,P2P9)}} * 100$$

For more information see Figure 8.

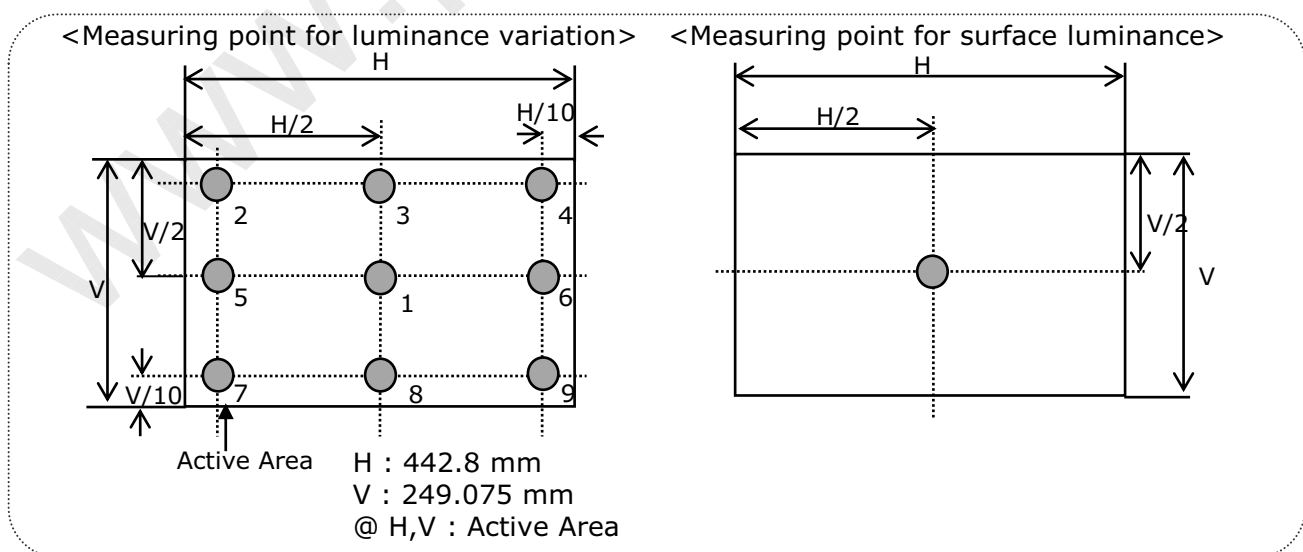
FIG. 8 Luminance measuring point

Product Specification

Notes :

4. Response time is the time required for the display to transition from black to white (Decay Time, Tr_D) and from white to black (Rise Time, Tr_R)
 The sampling rate is 500K sample/sec. For additional information see FIG. 9.

The response time is defined as the following figure and shall be measured by switching the input signal for each gray to gray.

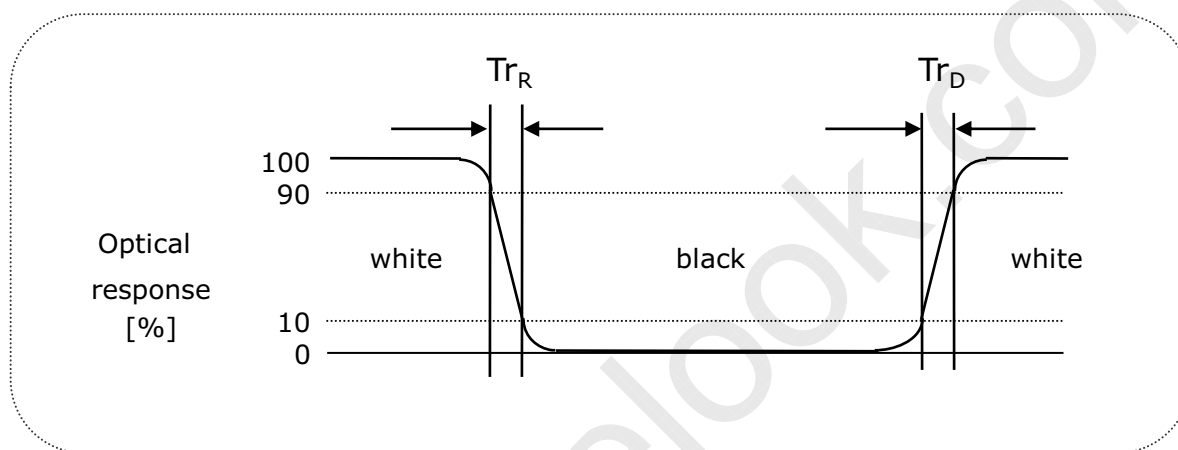
FIG. 9 Response time (measurement equipment : RD-80S)

5. Viewing angle is the angle at which the contrast ratio is greater than 10 or 5. The angles are determined for the horizontal or x axis and the vertical or y axis with respect to the z axis which is normal to the LCD surface. For more information see FIG. 10 .

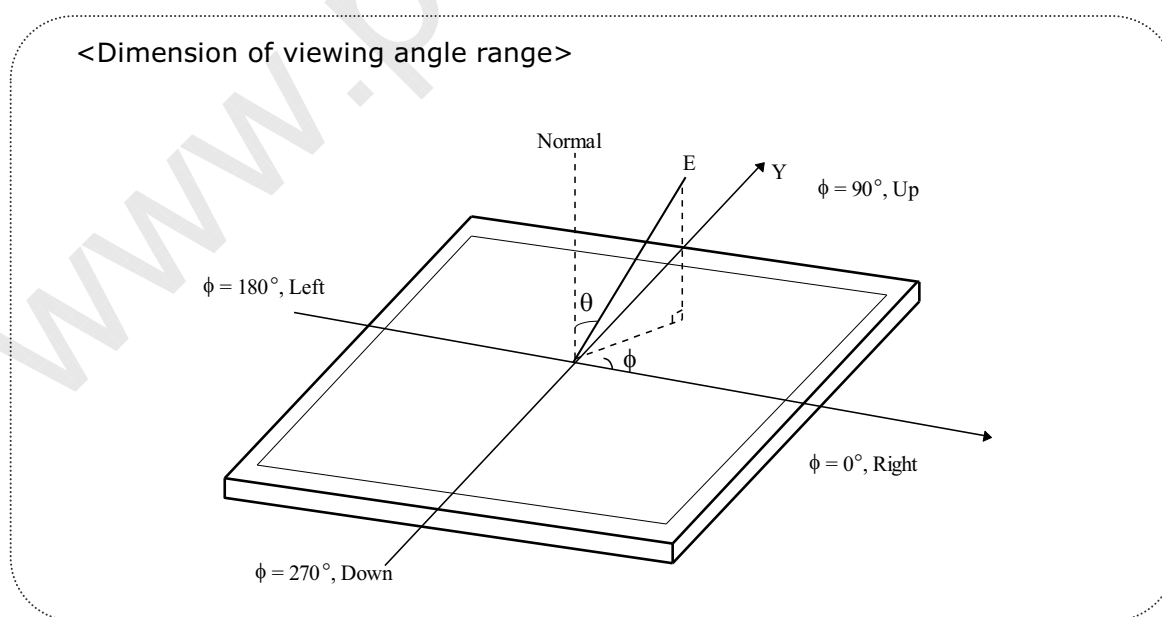
FIG. 10 Viewing angle

Product Specification

Notes :

6. Crosstalk is defined as

$$\begin{aligned} \text{The equation of crosstalk : } & (|L_{A[\text{or } C]2} - L_{A[\text{or } C]1}| / L_{A[\text{or } C]1}) \times 100(\%) \quad [\text{Vertical}], \\ & (|L_{B[\text{or } D]2} - L_{B[\text{or } D]1}| / L_{B[\text{or } D]1}) \times 100(\%) \quad [\text{Horizontal}] \end{aligned}$$

For more information see Figure 11.

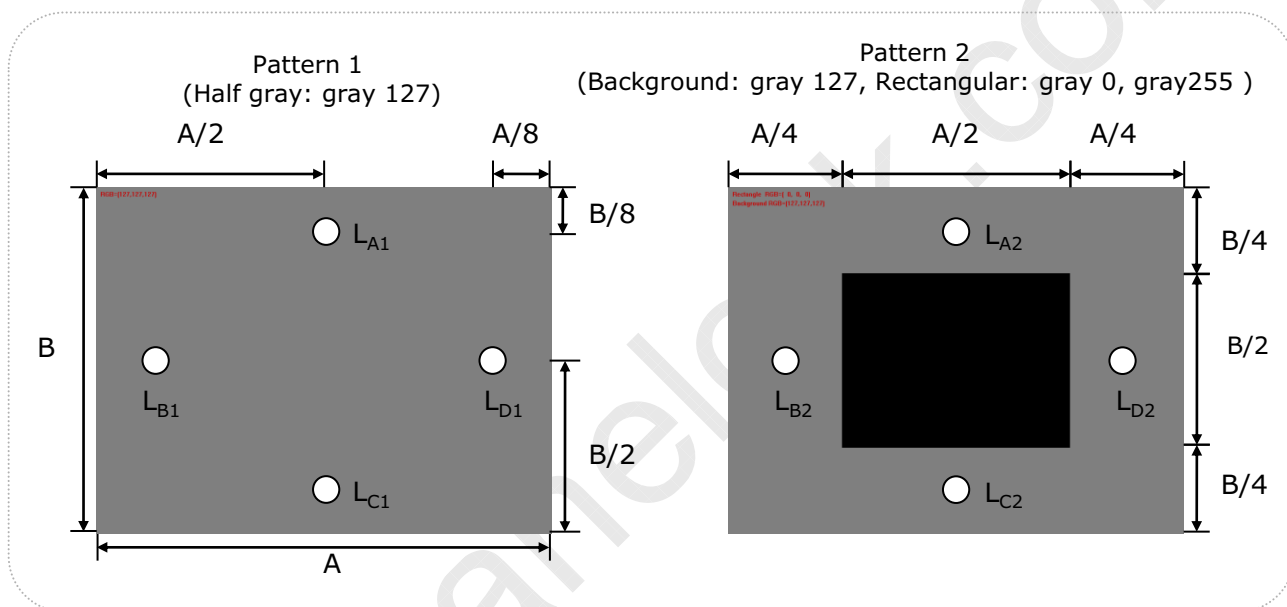
FIG. 11 Crosstalk measuring point

Product Specification

Notes :

7. Luminance Uniformity - angular - dependence (LR& TB)

TCO 5.0 Luminance uniformity - angular dependence, is the capacity of the VDU to present the same Luminance level independently of the viewing direction. The angular-dependent luminance uniformity is calculated as the ratio of maximum luminance to minimum luminance in the specified measurement areas.

- Test pattern : Full white $4^{\circ} \times 4^{\circ}$ square size, back ground shall be set to 80% image loading, RGB 204, 204, 204
- Test luminance : $\geq 150 \text{cd/m}^2$
- Test point : 5-point
- Test distance : $D * 1.5 = 76.22 \text{cm}$
- Test method : $L_R = ((L_{\text{max.}+30\text{deg.}} / L_{\text{min.}+30\text{deg.}}) + (L_{\text{max.}-30\text{deg.}} / L_{\text{min.}-30\text{deg.}})) / 2$
 $T_B = ((L_{\text{max.}+15\text{deg.}} / L_{\text{min.}+15\text{deg.}})$

FIG. 12 Luminance Uniformity angular dependence

< Luminance uniformity - angular dependence measuring point >

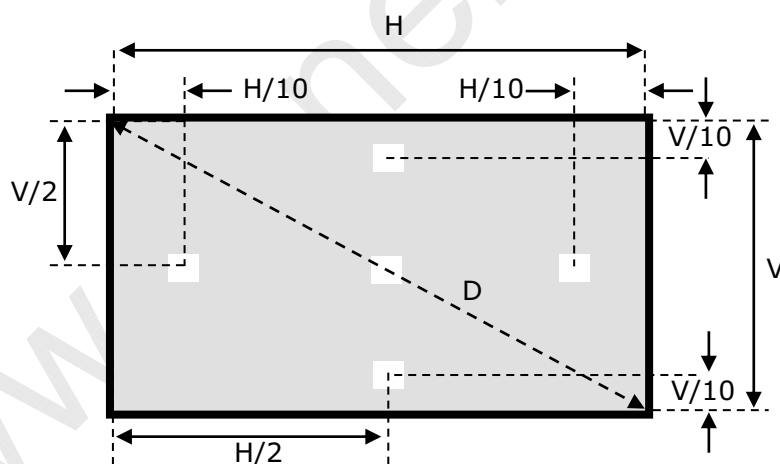

Product Specification

Notes :

 8. Color grayscale linearity , $\Delta u'v'$ is defined as

$$\sqrt{(u'_A - u'_B)^2 + (v'_A - v'_B)^2}$$

Where indices A and B are the two gray levels found to have the largest color differences between them.

 i.e. get the largest $\Delta u'$ and $\Delta v'$ of each 6pairs of u' and v' and calculate $\Delta u'v'$.

-Test pattern : 100% full white pattern with a test pattern as shown FIG.12
 Squares of 40mm by 40mm in size, filled with 255, 225, 195, 165, 135 and 105 grayscale steps should be arranged in the center of the screen.

-Test method

First gray step : move a square of 255 gray level should be moved into the center of the screen and measure luminance and u' and v' coordinates.

Next gray step : move a 255 gray square into the center and measure both luminance and u' and v' coordinates.

The same procedure shall then be repeated for gray steps 195, 165, 135 and 105.

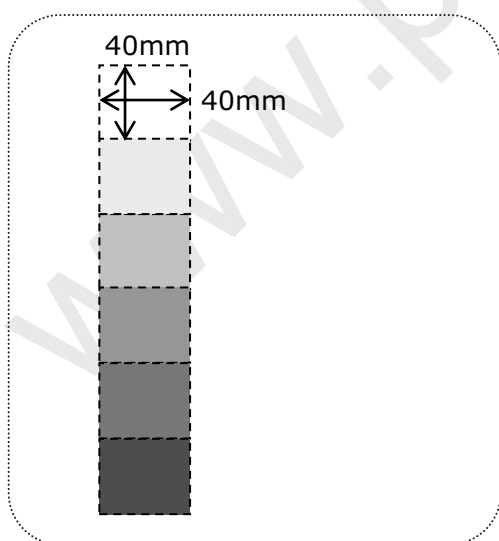
FIG. 13 Color grayscale linearity

Product Specification
5. Mechanical characteristics

The contents provide general mechanical characteristics. In addition the figures in the next page are detailed mechanical drawing of the LCD.

Table 11. Mechanical characteristics

Outline dimension	Horizontal	462.8 mm
	Vertical	272.0 mm
	Depth	10.2 mm
Bezel area	Horizontal	446.8 mm
	Vertical	253.1 mm
Active display area	Horizontal	442.8 mm
	Vertical	249.075 mm
Weight	1,490g (Typ.), 1,565g (Max)	
Surface treatment	Hard coating(3H) Anti-glare treatment of the front polarizer	

Notes : Please refer to a mechanic drawing in terms of tolerance at the next page.

Product Specification

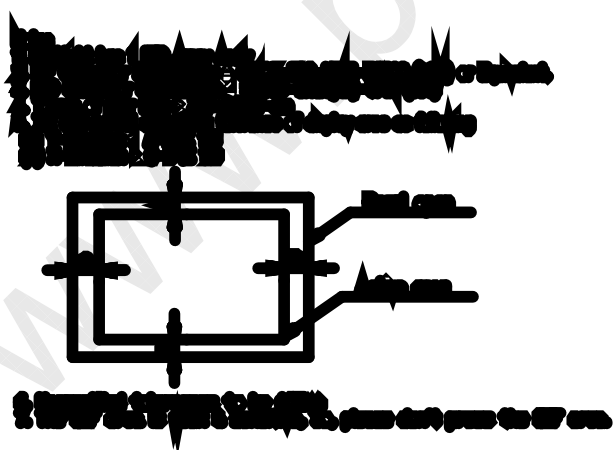
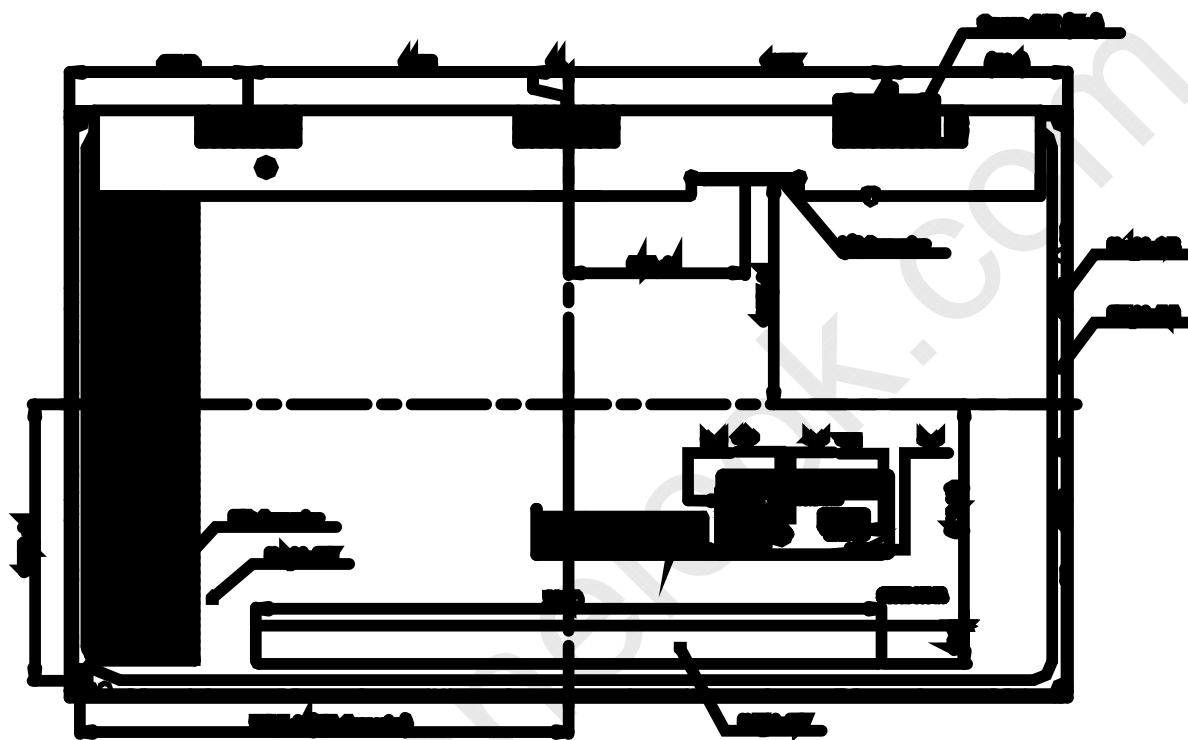
<REAR VIEW>

Product Specification
6. Reliability
Table 12. Environment test conditions

No	Test Item	Condition
1	High temperature storage test	Ta= 60°C 240hrs
2	Low temperature storage test	Ta= -20°C 240hrs
3	High temperature operation test	Ta= 50°C 50%RH 240hrs
4	Low temperature operation test	Ta= 0°C 240hrs
5	Vibration test (non-operating)	Wave form : random Vibration level : 1.0GRMS Bandwidth : 10-300Hz Duration : X,Y,Z, 20 min One time each direction
6	Shock test (non-operating)	Shock level : 120G Waveform : half sine wave, 2msec Direction : ±X, ±Y, ±Z One time each direction
7	Altitude operating storage / shipment	0 - 16,400 feet(5,000m) 0 - 40,000 feet(12,192m)

{ Result evaluation criteria }

There should be no change which might affect the practical display function when the display quality test is conducted under normal operating condition.

Product Specification**7. International standards****7-1. Safety**

- a) UL 60950-1, Underwriters Laboratories Inc.
Information Technology Equipment - Safety - Part 1 : General Requirements.
- b) CAN/CSA C22.2 No.60950-1-07, Canadian Standards Association.
Information Technology Equipment - Safety - Part 1 : General Requirements.
- c) EN 60950-1:2006 + A11:2009, European Committee for Electrotechnical Standardization(CENELEC).
Information Technology Equipment - Safety - Part 1 : General Requirements.
- d) IEC 60950-1, The International Electrotechnical commission(IEC).
Information Technology Equipment - Safety - Part 1 : General Requirements.
(Including report of IEC60825-1:2001 clause 8 and clause 9)

Notes

- 1. Laser (LED Backlight) Information

Class 1M LED Product IEC60825-1 : 2001 Embedded LED Power (Class1M)

- 2. Caution
: LED inside.
Class 1M laser (LEDs) radiation when open.
Do not open while operating.

7-2. EMC

- a) ANSI C63.4 "American National Standard for Methods of Measurement of Radio-Noise Emissions from Low-Voltage Electrical and Electronic Equipment in the Range of 9 kHz to 40 GHz."
American National Standards Institute (ANSI), 2003.
- b) CISPR 22 "Information technology equipment – Radio disturbance characteristics – Limit and methods of measurement." International Special Committee on Radio Interference (CISPR), 2005.
- c) CISPR 13 "Sound and television broadcast receivers and associated equipment – Radio disturbance characteristics – Limits and method of measurement."
International Special Committee on Radio Interference (CISPR), 2006.

7-3. Environment

- a) RoHS, Directive 2002/95/EC of the European Parliament and of the council of 27 January 2003

Product Specification

8. Packing

8-1. Designation of lot mark

a) Lot mark

A	B	C	D	E	F	G	H	I	J	K	L	M
---	---	---	---	---	---	---	---	---	---	---	---	---

A,B,C : Size (Inch)

E : Month

D : Year

F ~ M : Serial No.

Note:

1. Year

Year	2011	2012	2013	2014	2015	2016	2017	2018	2019	2020
Mark	A	B	C	D	E	F	G	H	J	K

2. Month

Month	Jan	Feb	Mar	Apr	May	Jun	Jul	Aug	Sep	Oct	Nov	Dec
Mark	1	2	3	4	5	6	7	8	9	A	B	C

b) Location of lot mark

Serial No. is printed on the label. The label is attached to the backside of the LCD module.
 This is subject to change without prior notice.

8-2. Packing form

a) Package quantity in one box : 12 pcs(2 Modules are packed in 1 AL Bag.)

b) Box size : 355mm x 305mm X 560mm

Product Specification**9. Precautions**

Please pay attention to the followings when you use this TFT LCD module.

9-1. Mounting Precautions

- (1) You must mount a module using holes arranged in left & right sides.
- (2) You should consider the mounting structure so that uneven force (ex. Twisted stress) is not applied to the Module. And the case on which a module is mounted should have sufficient strength so that external force is not transmitted directly to the module.
- (3) Please attach the surface transparent protective plate to the surface in order to protect the polarizer. Transparent protective plate should have sufficient strength in order to resist external force.
- (4) You should adopt radiation structure to satisfy the temperature specification.
- (5) Acetic acid type and chlorine type materials for the cover case are not desirable because the former generates corrosive gas of attacking the polarizer at high temperature and the latter causes circuit break by electro-chemical reaction.
- (6) Do not touch, push or rub the exposed polarizers with glass, tweezers or anything harder than HB pencil lead. And please do not rub with dust clothes with chemical treatment. Do not touch the surface of polarizer for bare hand or greasy cloth.
(Some cosmetics are detrimental to the polarizer.)
- (7) When the surface becomes dusty, please wipe gently with absorbent cotton or other soft materials like chamois soaks with petroleum benzene. Normal-hexane is recommended for cleaning the adhesives used to attach front / rear polarizers. Do not use acetone, toluene and alcohol because they cause chemical damage to the polarizer.
- (8) Wipe off saliva or water drops as soon as possible. Their long time contact with polarizer causes deformations and color fading.
- (9) Do not open the case because inside circuits do not have sufficient strength.

9-2. Operating precautions

- (1) The spike noise causes the mis-operation of circuits. It should be lower than following voltage : $V = \pm 200\text{mV}$ (Over and under shoot voltage)
- (2) Response time depends on the temperature. (In lower temperature, it becomes longer.)
- (3) Brightness depends on the temperature. (In lower temperature, it becomes higher.)
And in lower temperature, response time (required time that brightness is stable after turned on) becomes longer.
- (4) Be careful for condensation at sudden temperature change. Condensation makes damage to polarizer or electrical contacted parts. And after fading condensation, smear or spot will occur.
- (5) When fixed patterns are displayed for a long time, remnant image is likely to occur.
- (6) Module has high frequency circuits. Sufficient suppression to the electromagnetic interference shall be done by system manufacturers. Grounding and shielding methods may be important to minimized the interference.
- (7) Please do not give any mechanical and/or acoustical impact to LCM. Otherwise, LCM can not be operated its full characteristics perfectly.
- (8) A screw which is fastened up the steels should be a machine screw (if not, it causes metal foreign material and deal LCM a fatal blow)
- (9) Please do not set LCD on its edge.

Product Specification**9-3. Electrostatic discharge control**

Since a module is composed of electronic circuits, it is not strong to electrostatic discharge. Make certain that treatment persons are connected to ground through wrist band etc. And don't touch interface pin directly.

9-4. Precautions for strong light exposure

Strong light exposure causes degradation of polarizer and color filter.

9-5. Storage

When storing modules as spares for a long time, the following precautions are necessary.

- (1) Store them in a dark place. Do not expose the module to sunlight or fluorescent light. Keep the temperature between 5°C and 35°C at normal humidity.
- (2) The polarizer surface should not come in contact with any other object.
It is recommended that they be stored in the container in which they were shipped.

9-6. Handling precautions for protection film

- (1) The protection film is attached to the bezel with a small masking tape.
When the protection film is peeled off, static electricity is generated between the film and polarizer. This should be peeled off slowly and carefully by people who are electrically grounded and with well ion-blown equipment or in such a condition, etc.
- (2) When the module with protection film attached is stored for a long time, sometimes there remains a very small amount of glue still on the bezel after the protection film is peeled off.
- (3) You can remove the glue easily. When the glue remains on the bezel surface or its vestige is recognized, please wipe them off with absorbent cotton waste or other soft material like chamois soaked with normal-hexane.