

## SPECIFICATION FOR APPROVAL

- ( ) Preliminary Specification
- (●) Final Specification

Title	20.1" UXGA TFT LCD
-------	--------------------

BUYER	NDS
MODEL	

SUPPLIER	LG Display Co., Ltd.
*MODEL	LM201U05
SUFFIX	SLM1

www.jxlcd.com

\*When you obtain standard approval, please use the above model name without suffix

APPROVED BY	SIGNATURE DATE
/	_____
/	_____
/	_____

Please return 1 copy for your confirmation with your signature and comments.

APPROVED BY	SIGNATURE DATE
Hans. Kim / G.Manager	108 08.07.21
<b>REVIEWED BY</b>	
C. K. Lee / Manager [C]	08.07.21
J. H. Lee / Manager [M]	
G.T. Kim / Manager [P]	
<b>PREPARED BY</b>	
C.W. Lim / Engineer	

**MNT Products Engineering Dept.**  
**LG Display Co., Ltd**

## Product Specification

## Contents

No	ITEM	Page
	COVER	1
	CONTENTS	2
	RECORD OF REVISIONS	3
1	GENERAL DESCRIPTION	4
2	ABSOLUTE MAXIMUM RATINGS	5
3	ELECTRICAL SPECIFICATIONS	6
3-1	ELECTRICAL CHARACTERISTICS	6
3-2	INTERFACE CONNECTIONS	9
3-3	SIGNAL TIMING SPECIFICATIONS	16
3-4	SIGNAL TIMING WAVEFORMS	17
3-5	COLOR INPUT DATA REFERENCE	18
3-6	POWER SEQUENCE	19
4	OPTICAL SPECIFICATIONS	20
5	MECHANICAL CHARACTERISTICS	25
6	RELIABILITY	28
7	INTERNATIONAL STANDARDS	29
7-1	SAFETY	29
7-2	EMC	29
7-3	ENVIRONMENT	29
8	PACKING	30
8-1	DESIGNATION OF LOT MARK	30
8-2	PACKING FORM	31
8-3	PALLET FORM	32
9	PRECAUTIONS	33



## Product Specification

## 1. General Description

LM201U05-SLM1 is a Color Active Matrix Liquid Crystal Display with an integral Cold Cathode Fluorescent Lamp(CCFL) backlight system. The matrix employs a-Si Thin Film Transistor as the active element. It is a transmissive type display operating in the normally black mode. It has a 20.1 inch diagonally measured active display area with UXGA resolution (1200 vertical by 1600 horizontal pixel array)

Each pixel is divided into Red, Green and Blue sub-pixels or dots which are arranged in vertical stripes.

Gray scale or the brightness of the sub-pixel color is determined with a 8-bit gray scale signal for each dot, thus, presenting a palette of more than 16,7M(True) colors.

It has been designed to apply the 8Bit 2 port LVDS interface.

It is intended to support displays where high brightness, super wide viewing angle, high color saturation, and high color are important.

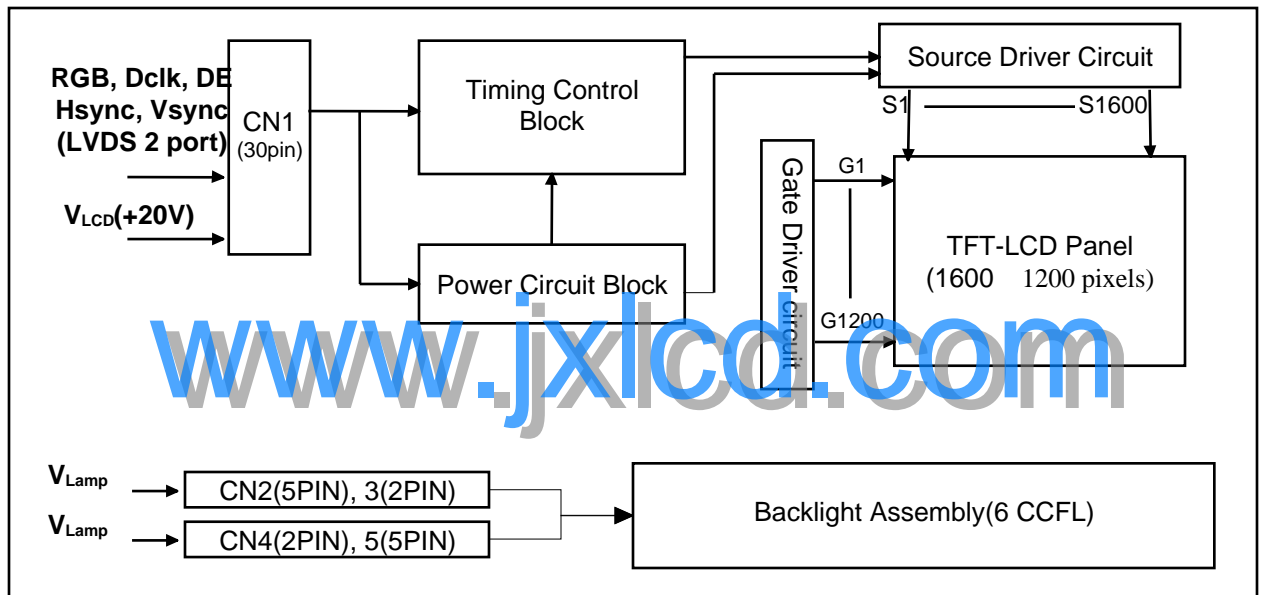

## General Features

Active Screen Size	20.1 inches(510.54mm) diagonal
Outline Dimension	432.0(H) x 331.5(V) x 25.0(D) mm(Typ.)
Pixel Pitch	0.255mm x 0.255mm
Pixel Format	1600 horizontal By 1200 vertical Pixels RGB stripe arrangement
Color Depth	8bit, 16,7 M colors
Luminance, White	300 cd/m <sup>2</sup> (Center 1 point, Typ.)
Viewing Angle (CR>10)	Viewing Angle Free ( R/L 178(Typ.), U/D 178(Typ) )
Power Consumption	Total 35.38 Watt(Typ.) (5.98 Watt@V <sub>LCD</sub> , 29.4 Watt@300cd/[LAMP=7mA])
Weight	3200 g (Typ.)
Display Operating Mode	Transmissive mode, normally black
Surface Treatment	Hard coating (3H), Anti-glare treatment of the front polarizer

## 2. Absolute Maximum Ratings

The following are maximum values which, if exceeded, may cause faulty operation or damage to the unit.

**Table 1. ABSOLUTE MAXIMUM RATINGS**

Parameter	Symbol	Values		Units	Notes
		Min	Max		
Power Input Voltage	V <sub>LCD</sub>	-0.3	23.0	V <sub>dc</sub>	at 25 ± 2 °C
Operating Temperature	T <sub>OP</sub>	0	50	°C	1
Storage Temperature	T <sub>ST</sub>	-20	60	°C	1
Operating Ambient Humidity	H <sub>OP</sub>	10	90	%RH	1
Storage Humidity	H <sub>ST</sub>	10	90	%RH	1

Note : 1. Temperature and relative humidity range are shown in the figure below.  
Wet bulb temperature should be 39 °C Max, and no condensation of water.

[www.jxlcd.com](http://www.jxlcd.com)

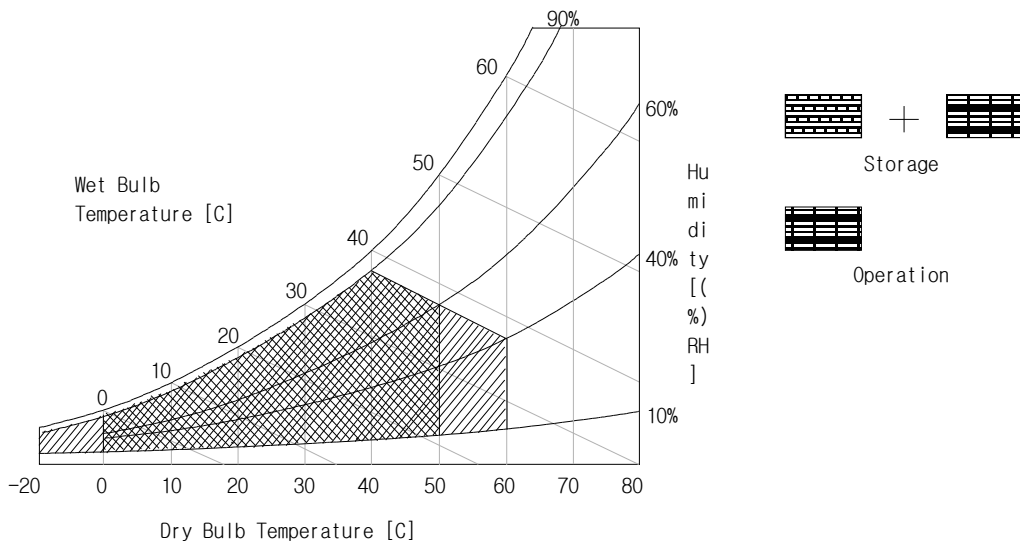

Product Specification

**3. Electrical Specifications**

**3-1. Electrical Characteristics**

It requires two power inputs. One is employed to power the LCD electronics and to drive the TFT array and liquid crystal. The second input power for the CCFL, is typically generated by an inverter. The inverter is an external unit to the LCDs.

**Table 2\_1. ELECTRICAL CHARACTERISTICS**

Parameter	Symbol	Values			Unit	Notes
		Min	Typ	Max		
MODULE :						
Power Supply Input Voltage	V <sub>LCD</sub>	17V	18V	19V	V <sub>dc</sub>	
Power Supply Input Current	I <sub>LCD</sub>	-	332	382	mA	1
		-	419	481	mA	2
Power Consumption	P <sub>LCD</sub>	-	5.98	6.88	Watt	1
Rush current	I <sub>RUSH</sub>	-	-	3	A	3

Note :

1. The specified current and power consumption are under the V<sub>CC</sub>=18.0V, 25 ± 2°C, f<sub>v</sub>=60Hz condition whereas mosaic pattern(8 x 6) is displayed and f<sub>v</sub> is the frame frequency.
2. The current is specified at the maximum current pattern.
3. The duration of rush current is about 2ms and rising time of power Input is 1ms(min.).

White : 255Gray  
Black : 0Gray

Maximum current pattern

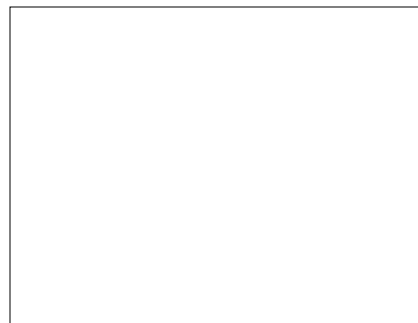
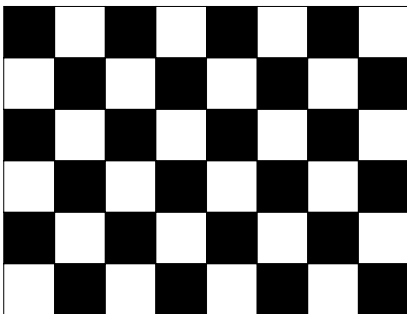

Mosaic Pattern(8 x 6)

White Pattern

## Product Specification

**Table 2\_2. ELECTRICAL CHARACTERISTICS**

Parameter	Symbol	Values			Unit	Notes
		Min	Typ	Max		
LAMP :						
Operating Voltage	V <sub>BL</sub>	670(8.0mA)	700	825(3mA)	V <sub>RMS</sub>	1, 3
Operating Current	I <sub>BL</sub>	3.0	7.0	8.0	mA <sub>RMS</sub>	2
Established Starting Voltage	V <sub>s</sub>					2, 4
	at 25 °C			1150	V <sub>RMS</sub>	
	at 0 °C			1450	V <sub>RMS</sub>	
Operating Frequency	f <sub>BL</sub>	40	50	80	kHz	5
Discharge Stabilization Time	T <sub>s</sub>	-	-	3	Min	2, 6
Power Consumption	P <sub>BL</sub>		29.4	32.3	Watt	7
Life Time		45,000			Hrs	2, 8

influenced by the characteristics of the DC-AC inverter. So all the parameters of an inverter should be carefully designed so as not to produce too much leakage current from high-voltage output of the inverter.

When you design or order the inverter, please make sure unwanted lighting caused by the mismatch of the lamp and the inverter (no lighting, flicker, etc) never occurs. When you confirm it, the LCD

Assembly should be operated in the same condition as installed in you instrument.

※ Do not attach a conducting tape to lamp connecting wire.

If the lamp wire attach to a conducting tape, TFT-LCD Module has a low luminance and the inverter has abnormal action. Because leakage current is occurred between lamp wire and conducting tape.

1. It is only reference voltage in LCM.

2. Specified values are for a single lamp.

3. Operating voltage is measured at 25 °C.

4. The voltage above V<sub>s</sub> should be applied to the lamps for more than 1 second for start-up.

(Inverter open voltage must be more than lamp starting voltage.)

Otherwise, the lamps may not be turned on. The used lamp current is the lamp typical

current.

5. Lamp frequency may produce interface with horizontal synchronous frequency and as a result this may

cause beat on the display. Therefore lamp frequency shall be as away possible from the horizontal synchronous frequency and from its harmonics in order to prevent interference.

6. Let's define the brightness of the lamp after being lighted for 5 minutes as 100%.

T<sub>s</sub> is the time required for the brightness of the center of the lamp to be not less than 95%.

7. The lamp power consumption shown above does not include loss of external inverter.

The used lamp current is the lamp typical current. (P<sub>BL</sub> = V<sub>BL</sub> × I<sub>BL</sub> × N<sub>Lamp</sub> )

8. The life is determined as the time at which brightness of the lamp is 50% compared to that of initial

value at the typical lamp current on condition of continuous operating at 25 °C.

Product Specification

9. The output of the inverter must have symmetrical(negative and positive) voltage waveform and symmetrical current waveform (Unsymmetrical ratio is less than 10%). Please do not use the inverter which has unsymmetrical voltage and unsymmetrical current and spike wave. Requirements for a system inverter design, which is intended to have a better display performance, a better power efficiency and a more reliable lamp, are following.
- It shall help increase the lamp lifetime and reduce leakage current.
- a. The asymmetry rate of the inverter waveform should be less than 10%.
  - b. The distortion rate of the waveform should be within  $2 \pm 10\%$ .
- \* Inverter output waveform had better be more similar to ideal sine wave.

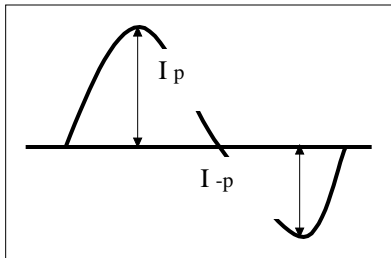

\* Asymmetry rate:

$$\frac{|I_p - I_{-p}|}{I_{rms}} \times 100\%$$

\* Distortion rate

$$I_p \text{ (or } I_{-p}) / I_{rms}$$

10. The inverter which is combined with this LCM, is highly recommended to connect coupling(ballast) condenser at the high voltage output side. When you use the inverter which has not coupling(ballast) condenser, it may cause abnormal lamp lighting because of biased mercury as time goes.
11. In case of edge type back light with over 4 parallel lamps, input current and voltage wave form should be synchronized



## Product Specification

### 3-2. Interface Connections

LCD Connector(CN1) : AL230F-ALG1D-P (Manufactured by P-TWO) or IS100-L30R-C23  
 (Manufactured by UJU) or Equivalent

Mating Connector : FI-X30M (Manufactured by JAE) or Equivalent

**Table 3. MODULE CONNECTOR(CN1) PIN CONFIGURATION**

Pin	Symbol	Description
1	Vcc	Supply voltage for LCD module
2	Vcc	Supply voltage for LCD module
3	Vcc	Supply voltage for LCD module
4	Vcc	Supply voltage for LCD module
5	NC	NC (No Connection)
6	NC	NC (No Connection)
7	SR3P	Plus signal of even channel 3 (LVDS)
8	SR3M	Minus signal of even channel 3 (LVDS)
9	SCLKINP	Plus signal of even clock channel (LVDS)
10	SCLKINM	Minus signal of even clock channel (LVDS)
11	SR2P	Plus signal of even channel 2 (LVDS)
12	SR2M	Minus signal of even channel 2 (LVDS)
13	SR1P	Plus signal of even channel 1 (LVDS)
14	SR1M	Minus signal of even channel 1 (LVDS)
15	SR0P	Plus signal of even channel 0 (LVDS)
16	SR0M	Minus signal of even channel 0 (LVDS)
17	GND	Ground
18	GND	Ground
19	FR3P	Plus signal of odd channel 3 (LVDS)
20	FR3M	Minus signal of odd channel 3 (LVDS)
21	FCLKINP	Plus signal of odd clock channel (LVDS)
22	FCLKINM	Minus signal of odd clock channel (LVDS)
23	FR2P	Plus signal of odd channel 2 (LVDS)
24	FR2M	Minus signal of odd channel 2 (LVDS)
25	FR1P	Plus signal of odd channel 1 (LVDS)
26	FR1M	Minus signal of odd channel 1 (LVDS)
27	FR0P	Plus signal of odd channel 0 (LVDS)
28	FR0M	Minus signal of odd channel 0 (LVDS)
29	GND	Ground
30	GND	Ground

Second data

First data

Note: 1. NC: No Connection.

2. All GND(ground) pins should be connected together and to Vss which should also be connected to

the LCD's metal frame.

3. All VLCD (power input) pins should be connected together.

4. Input Level of LVDS signal is based on the IEA 664 Standard.

Product Specification

**User Connector Diagram**

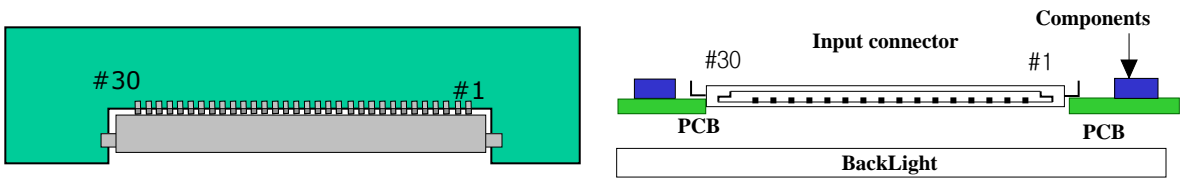

AL230F-ALG1D-P ( P-TWO)

Rear view of LCM

[www.jxlcd.com](http://www.jxlcd.com)

## Product Specification

**Table 4. REQUIRED SIGNAL ASSIGNMENT FOR Flat Link (TI:SN75LVDS83) Transmitter**

Pin #	Pin Name	Require Signal	Pin #	Pin Name	Require Signal
1	Vcc	Power Supply for TTL Input	29	GND	Ground pin for TTL
2	D5	TTL Input (R7)	30	D26	TTL Input (DE)
3	D6	TTL Input (R5)	31	T <sub>x</sub> CLKIN	TTL Level clock Input
4	D7	TTL Input (G0)	32	PWR DWN	Power Down Input
5	GND	Ground pin for TTL	33	PLL GND	Ground pin for PLL
6	D8	TTL Input (G1)	34	PLL Vcc	Power Supply for PLL
7	D9	TTL Input (G2)	35	PLL GND	Ground pin for PLL
8	D10	TTL Input (G6)	36	LVDS GND	Ground pin for LVDS
9	Vcc	Power Supply for TTL Input	37	TxOUT3 +	Positive LVDS differential data output 3
10	D11	TTL Input (G7)	38	TxOUT3 -	Negative LVDS differential data output 3
11	D12	TTL Input (G3)	39	T <sub>x</sub> CLKOUT +	Positive LVDS differential clock output
12	D13	TTL Input (G4)	40	T <sub>x</sub> CLKOUT -	Negative LVDS differential clock output
13	GND	Ground pin for TTL	41	T <sub>x</sub> OUT2 +	Positive LVDS differential data output 2
14	D14	TTL Input (G5)	42	T <sub>x</sub> OUT2 -	Negative LVDS differential data output 2
15	D15	TTL Input (B0)	43	LVDS GND	Ground pin for LVDS
16	D16	TTL Input (B6)	44	LVDS Vcc	Power Supply for LVDS
17	Vcc	Power Supply for TTL Input	45	T <sub>x</sub> OUT1 +	Positive LVDS differential data output 1
18	D17	TTL Input (B7)	46	T <sub>x</sub> OUT1 -	Negative LVDS differential data output 1
19	D18	TTL Input (B1)	47	T <sub>x</sub> OUT0 +	Positive LVDS differential data output 0
20	D19	TTL Input (B2)	48	T <sub>x</sub> OUT0 -	Negative LVDS differential data output 0
21	GND	Ground pin for TTL Input	49	LVDS GND	Ground pin for LVDS
22	D20	TTL Input (B3)	50	D27	TTL Input (R6)
23	D21	TTL Input (B4)	51	D0	TTL Input (R0)
24	D22	TTL Input (B5)	52	D1	TTL Input (R1)
25	D23	TTL Input (RSVD)	53	GND	Ground pin for TTL
26	Vcc	Power Supply for TTL Input	54	D2	TTL Input (R2)
27	D24	TTL Input (HSYNC)	55	D3	TTL Input (R3)
28	D25	TTL Input (VSYNC)	56	D4	TTL Input (R4)

Notes : Refer to LVDS Transmitter Data Sheet for detail descriptions.

Product Specification

**LVDS Input characteristics**

1. DC Specification

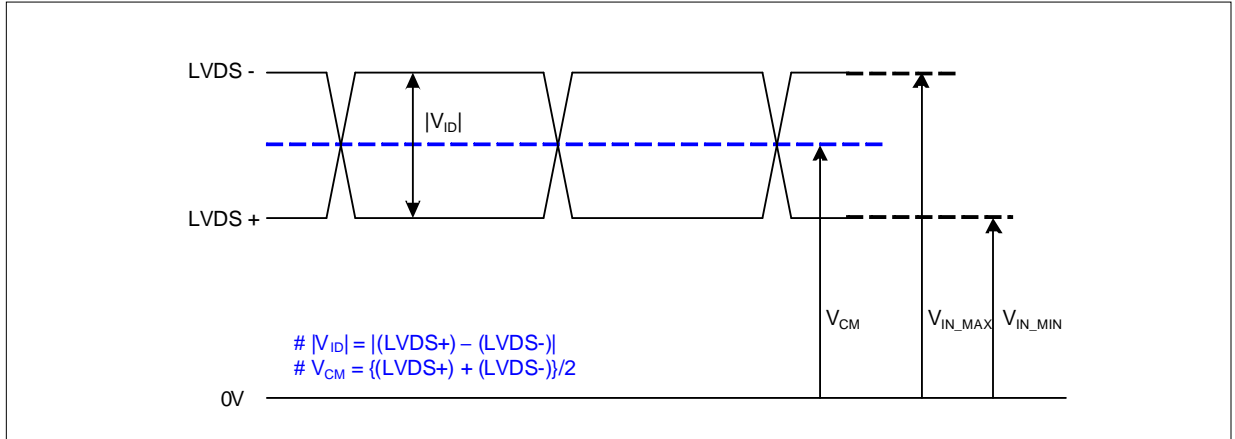

Description	Symbol	Min	Max	Unit	Notes
LVDS Differential Voltage	$ V_{ID} $	100	600	mV	-
LVDS Common mode Voltage	$V_{CM}$	0.6	1.8	V	-
LVDS Input Voltage Range	$V_{IN}$	0.3	2.1	V	-

2. AC Specification

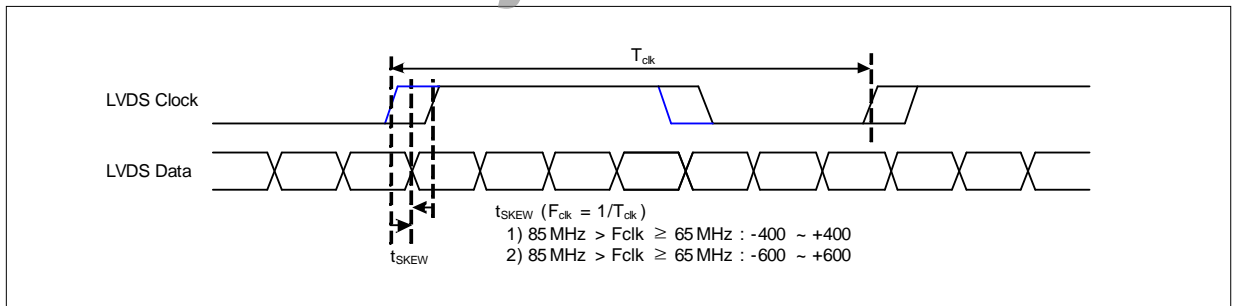

Description	Symbol	Min	Max	Unit	Notes
LVDS Clock to Data Skew Margin	$t_{SKEW}$	- 400	+ 400	ps	85MHz > Fclk 65MHz
	$t_{SKEW}$	- 600	+ 600	ps	65MHz > Fclk 25MHz
LVDS Clock to Clock Skew Margin (Even to Odd)	$t_{SKEW\_EO}$	- 1/7	+ 1/7	$T_{clk}$	-
Maximum deviation of input clock frequency during SSC	$F_{DEV}$	-	± 3	%	-
Maximum modulation frequency of input clock during SSC	$F_{MOD}$	-	200	KHz	-

Product Specification

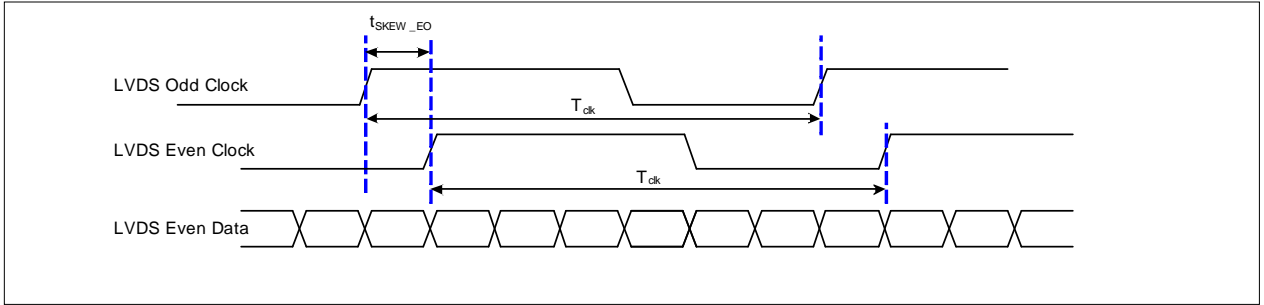

< Clock skew margin between channel >

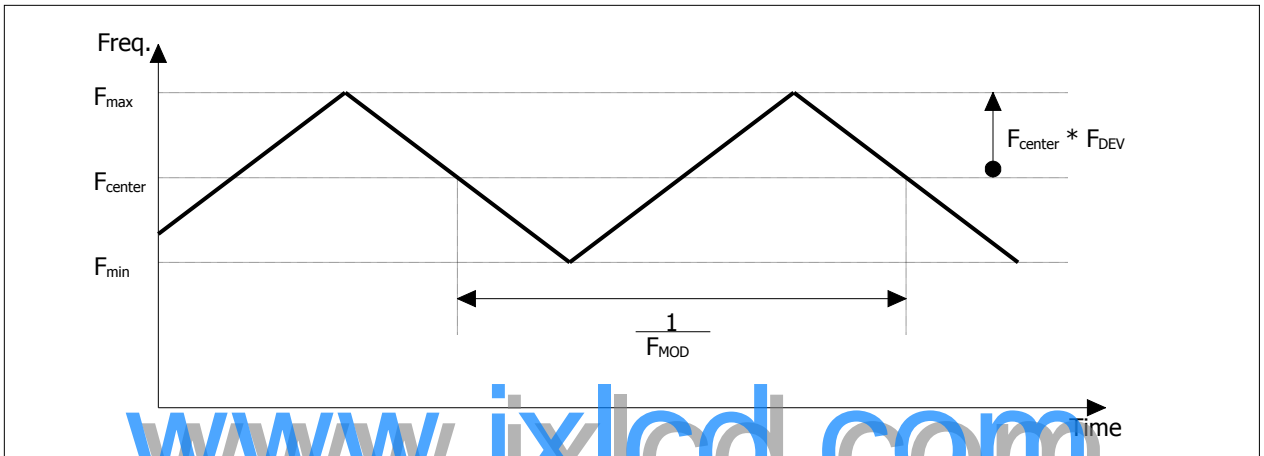

[www.jxlcd.com](http://www.jxlcd.com) < Spread Spectrum >

3. Data Format  
1) LVDS 2 Port

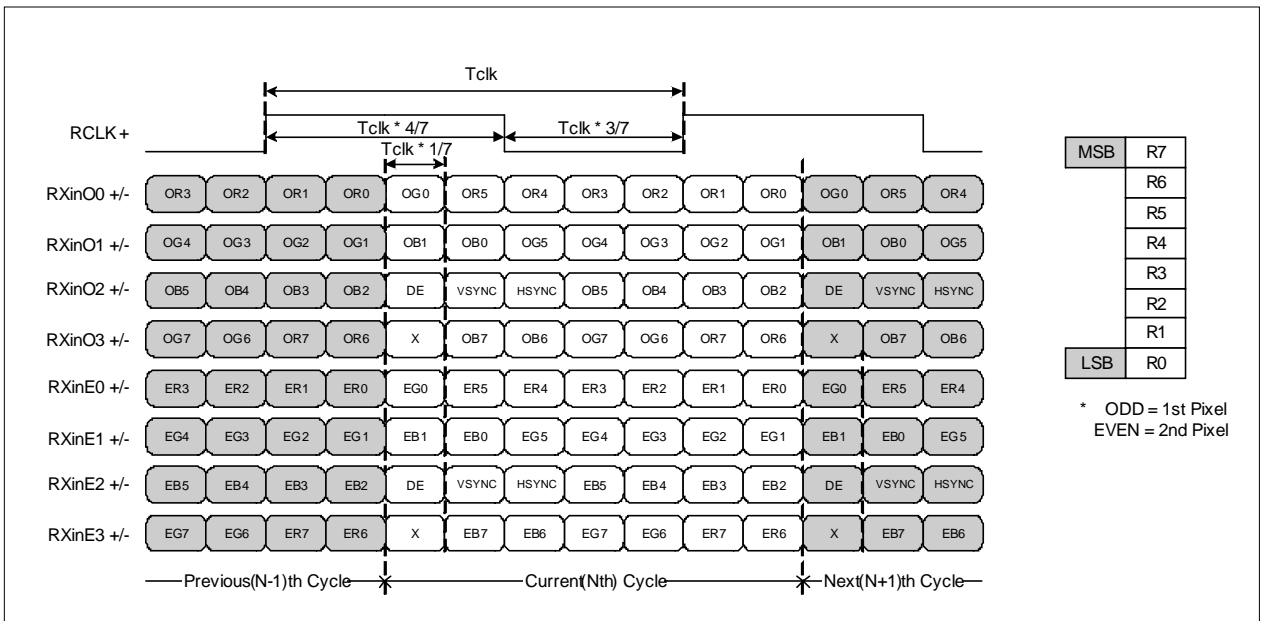

< LVDS Data Format >

Product Specification

2) LVDS 1 Port

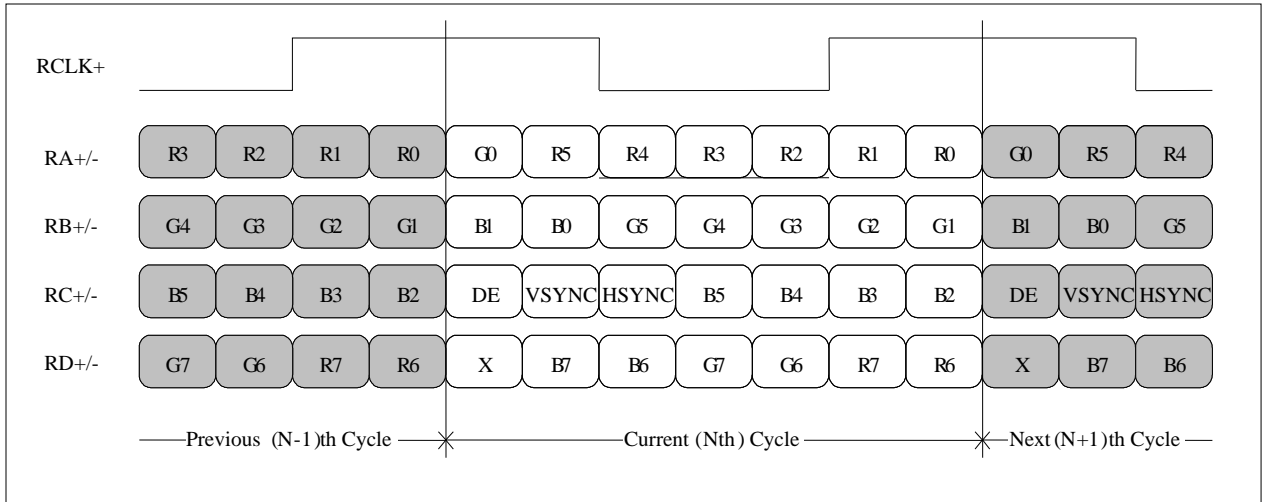

[www.jxlcd.com](http://www.jxlcd.com)

Product Specification

**Table 5. BACKLIGHT CONNECTOR PIN CONFIGURATION(CN2,CN3,CN4,CN5)**

The backlight interface connector is a model 1674817-1(CN3/CN4) manufactured by AMP ( or equivalent BHSR-02VS-1 manufactured by JST) and BHR-05VS-1 (CN2/CN5) manufactured by JST. The mating connector part number are SM02B-BHSS-1-TB(2pin), SM04(9-E2)B-BHS-1-TB or equivalent. The pin configuration for the connector is shown in the table below.

No	Pin	Symbol	Description	Notes
CN2	1	HV	Power supply for lamp 1(High voltage side)	1
	2	HV	Power supply for lamp 2(High voltage side)	1
	3	NC	NC	
	4	LV	Power supply for lamp 1(Low voltage side)	2
	5	LV	Power supply for lamp 2(Low voltage side)	2
CN3	1	HV	Power supply for lamp 3(High voltage side)	1
	2	LV	Power supply for lamp 3(Low voltage side)	2
CN4	1	HV	Power supply for lamp 4(High voltage side)	1
	2	LV	Power supply for lamp 4(Low voltage side)	2
CN5	1	HV	Power supply for lamp 6(High voltage side)	1
	2	HV	Power supply for lamp 5(High voltage side)	1
	3	NC	NC	
	4	LV	Power supply for lamp 6(Low voltage side)	2
	5	LV	Power supply for lamp 5(Low voltage side)	2

- Notes: 1. The high voltage power terminal is thick line.  
2. The low voltage power terminal is thin line.

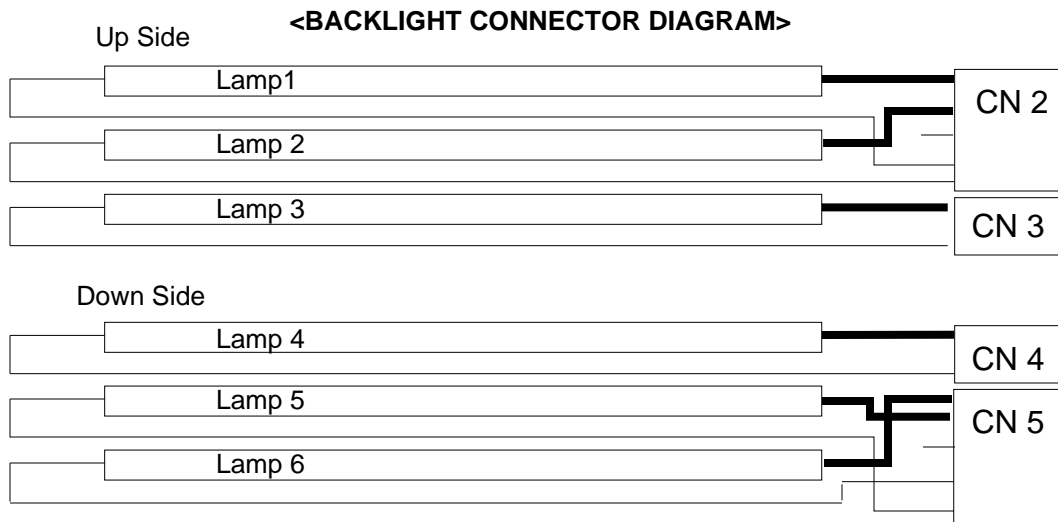

## Product Specification

### 3-3. Signal Timing Specifications

This is the signal timing required at the input of the User connector. All of the interface signal timing should be satisfied with the following specifications for its proper operation.

**Table 6. Timing Table**

ITEM		SYMBOL	Min	Typ	Max	Unit	Note
DCLK	Period	tCLK	14.28	15.625	16.00	ns	
	Frequency	fCLK	62.5	64.0	70.0	MHz	2pixel/clock
Hsync	Period	tHP	852	860	906	tCLK	
	Width-Active	tWH	16	16	16		
Vsync	Period	tVP	1230	1240	1250	tHP	
	Frequency	fV	59	60	61	Hz	
	Width-Active	tWV	2	4	4	tHP	
Data Enable	Horizontal Valid	tHV	800	800	800	tCLK	
	Horizontal Back Porch	tHBP	20	24	48		
	Horizontal Front Porch	tHFP	16	20	42		
	Horizontal Blank	-	52	60	106		
	Vertical Valid	tVV	1200	1200	1200	tHP	
	Vertical Back Porch	tVBP	24	32	42		
	Vertical Front Porch	tVFP	4	4	4		
	Vertical Blank	-	30	40	50		

Notes: Hsync period and Hsync width-active should be even number times of tCLK. If the value is odd number times of tCLK, display control signal can be asynchronous. In order to operate this LCM a Hsync, Vsync, and DE(data enable) signals should be used.

- The performance of the electro-optical characteristics may be influenced by variance of the vertical refresh rates.
- Vsync and Hsync should be keep the above specification.
- Hsync Period, Hsync Width, and Horizontal Back Porch should be any times of of character number(8).
- The polarity of Hsync, Vsync is not restricted.



### 3-4. Signal Timing Waveforms

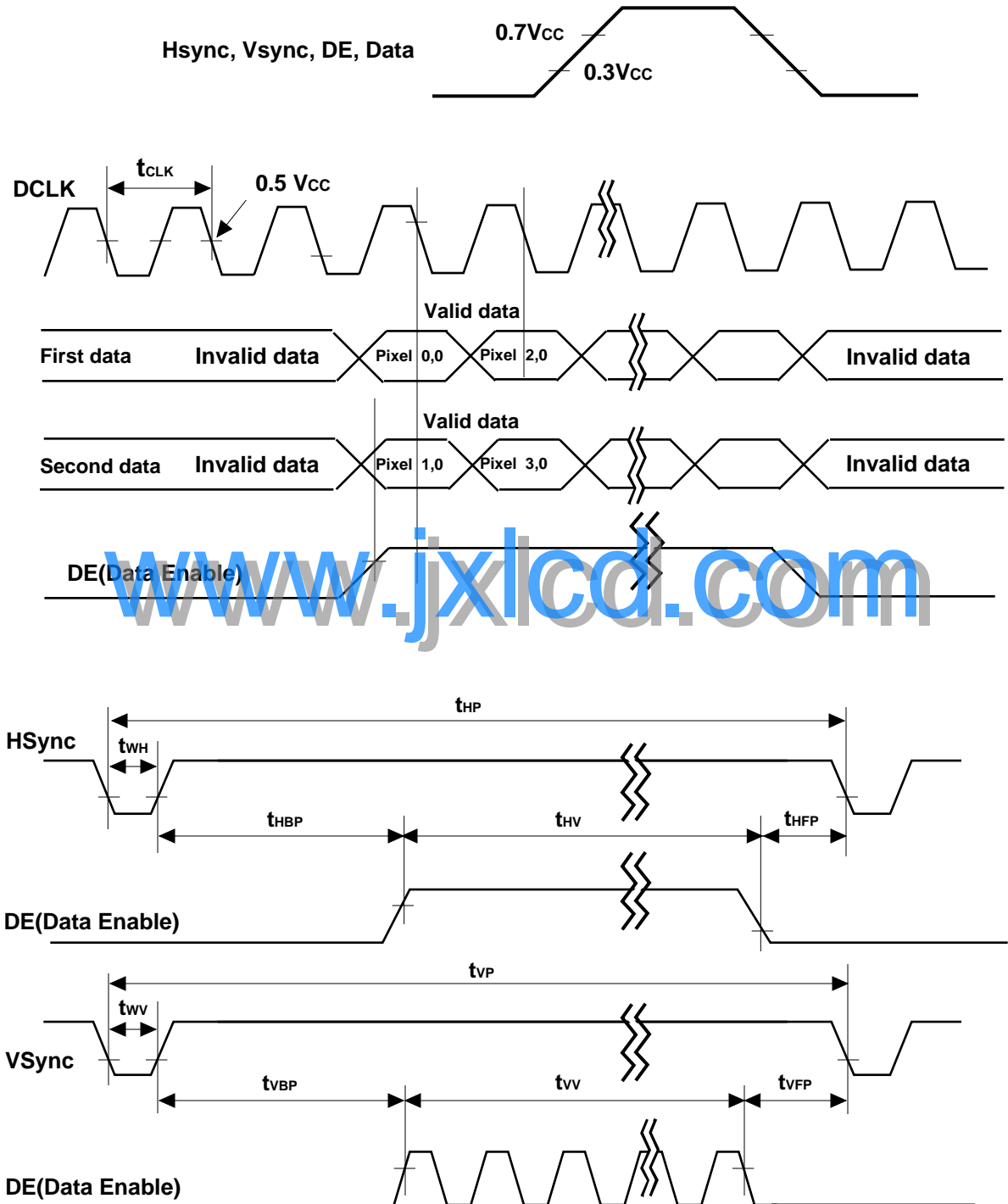

## Product Specification

**3-5. Color Data Reference**

The Brightness of each primary color(red,green,blue) is based on the 8-bit gray scale data input for the color; the higher the binary input, the brighter the color. The table below provides a reference for color versus data input.

**Table 7. COLOR DATA REFERENCE**

Color		Input Color Data																							
		RED								GREEN								BLUE							
		MSB				LSB				MSB				LSB				MSB				LSB			
		R7	R6	R5	R4	R3	R2	R1	R0	G7	G6	G5	G4	G3	G2	G1	G0	B7	B6	B5	B4	B3	B2	B1	B0
Basic Color	Black	0	0	0	0	0	0	0	0	0	0	0	0	0	0	0	0	0	0	0	0	0	0	0	0
	Red (255)	1	1	1	1	1	1	1	1	0	0	0	0	0	0	0	0	0	0	0	0	0	0	0	0
	Green (255)	0	0	0	0	0	0	0	0	1	1	1	1	1	1	1	1	0	0	0	0	0	0	0	0
	Blue (255)	0	0	0	0	0	0	0	0	0	0	0	0	0	0	0	0	1	1	1	1	1	1	1	1
	Cyan	0	0	0	0	0	0	0	0	1	1	1	1	1	1	1	1	1	1	1	1	1	1	1	1
	Magenta	1	1	1	1	1	1	1	1	0	0	0	0	0	0	0	0	1	1	1	1	1	1	1	1
	Yellow	1	1	1	1	1	1	1	1	1	1	1	1	1	1	1	1	0	0	0	0	0	0	0	0
	White	1	1	1	1	1	1	1	1	1	1	1	1	1	1	1	1	1	1	1	1	1	1	1	1
RED	RED (000) Dark	0	0	0	0	0	0	0	0	0	0	0	0	0	0	0	0	0	0	0	0	0	0	0	0
	RED (001)	0	0	0	0	0	0	0	1	0	0	0	0	0	0	0	0	0	0	0	0	0	0	0	0
	...	...								...								...							
	RED (254)	1	1	1	1	1	1	1	0	0	0	0	0	0	0	0	0	0	0	0	0	0	0	0	0
	RED (255)	1	1	1	1	1	1	1	1	0	0	0	0	0	0	0	0	0	0	0	0	0	0	0	0
GREEN	GREEN (000) Dark	0	0	0	0	0	0	0	0	0	0	0	0	0	0	0	0	0	0	0	0	0	0	0	0
	GREEN (001)	0	0	0	0	0	0	0	0	0	0	0	0	0	0	1	0	0	0	0	0	0	0	0	
	...	...								...								...							
	GREEN (254)	0	0	0	0	0	0	0	0	1	1	1	1	1	1	0	0	0	0	0	0	0	0	0	
	GREEN (255)	0	0	0	0	0	0	0	0	1	1	1	1	1	1	1	0	0	0	0	0	0	0	0	
BLUE	BLUE (000) Dark	0	0	0	0	0	0	0	0	0	0	0	0	0	0	0	0	0	0	0	0	0	0	0	0
	BLUE (001)	0	0	0	0	0	0	0	0	0	0	0	0	0	0	0	0	0	0	0	0	0	0	0	1
	...	...								...								...							
	BLUE (254)	0	0	0	0	0	0	0	0	0	0	0	0	0	0	0	0	1	1	1	1	1	1	0	
	BLUE (255)	0	0	0	0	0	0	0	0	0	0	0	0	0	0	0	0	1	1	1	1	1	1	1	

### 3-6. Power Sequence

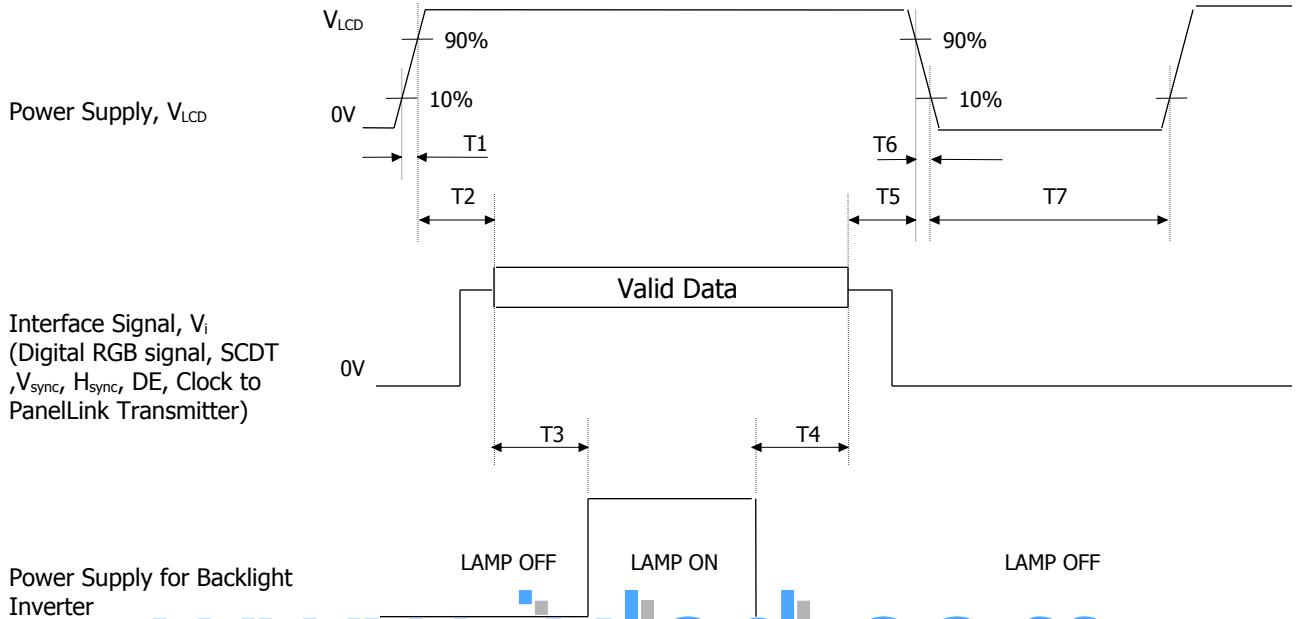

**Table 8. POWER SEQUENCE**

Parameter	Values			Units
	Min	Typ	Max	
T1	-	-	10	ms
T2	0.01	-	50	ms
T3	200	-	-	ms
T4	200	-	-	ms
T5	0.01	-	50	ms
T7	400	-	-	ms

**Notes :**

1. Please avoid floating state of interface signal at invalid period.
2. When the interface signal is invalid, be sure to pull down the power supply for LCD  $V_{CD}$  to 0V.
3. Lamp power must be turn on after power supply for LCD an interface signal are valid.

## Product Specification

**4. Optical Specification**

Optical characteristics are determined after the unit has been 'ON and stable for approximately 30 minutes in a dark environment at  $25 \pm 2^\circ\text{C}$ . The values specified are at an approximate distance 50cm from the LCD surface at a viewing angle of and equal to  $0^\circ$ .

FIG. 1 presents additional information concerning the measurement equipment and method.

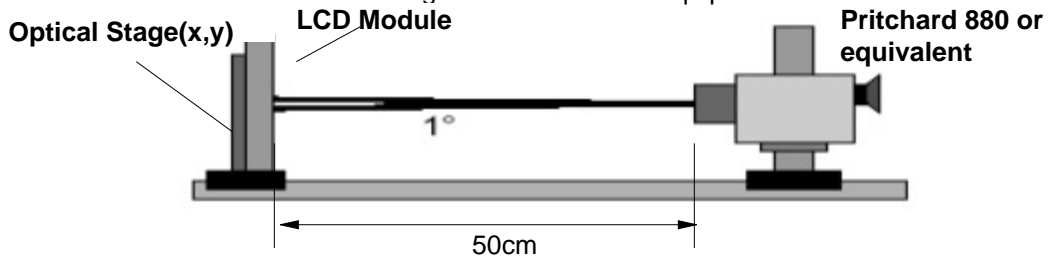
**FIG. 1 Optical Characteristic Measurement Equipment and Method**
**Table 9. OPTICAL CHARACTERISTICS**
 $T_a = 25^\circ\text{C}$ ,  $V_{\text{LCD}} = 18.0\text{V}$ ,  $f_v = 60\text{Hz}$  Dclk=128MHz,  $I_{\text{BL}} = 7\text{mA}$ 

Parameter	Symbol	Values			Units	Notes	
		Min	Typ	MAX			
Contrast Ratio	CR	400	800			1	
Surface Luminance, white	$L_{\text{WH}}$	250	300		$\text{cd}/\text{m}^2$	2	
Luminance Variation	WHITE	75	-	-	%	3	
Luminance uniformity Angular dependence (TCO'03)			-	1.7		FIG 3	
Response Time	Rise Time	$T_{\text{rR}}$	6.5	25	ms	4	
	Decay Time	$T_{\text{rD}}$	-	7.5	ms	4	
	Gray To Gray	$T_{\text{GTG\_AVR}}$	-	6	-	ms	5
		$T_{\text{GTG\_MAX}}$	-	12	-	ms	5
Color Coordinates							
	RED	RX	-0.03	0.639	+0.03		
		RY		0.342			
	GREEN	GX		0.295			
		GY		0.615			
	BLUE	BX		0.146			
		BY		0.072			
	WHITE	WX		0.313			
		WY		0.329			
Color shift							
	Horizontal	$\text{CST\_H}$	-	178	-	degree	
	Vertical	$\text{CST\_V}$	-	178	-		
Viewing Angle							
general	Horizontal	H	-	178	-	degree	
	Vertical	V	-	178	-		
Effective	Horizontal	$\text{GMA\_H}$	-	178	-	degree	
	Vertical	$\text{GMA\_V}$		178			
Gray Scale				2.2		9	

Product Specification

Notes 1. Contrast Ratio(CR) is defined mathematically as :

$$\text{Contrast Ratio} = \frac{\text{Surface Luminance with all white pixels}}{\text{Surface Luminance with all black pixels}}$$

2. Surface luminance is luminance value at No.1 point across the LCD surface 50cm from the surface with all pixels displaying white. For more information see FIG 2.

3. The variation in surface luminance , WHITE is defined as :

$$\text{WHITE} = \frac{\text{Minimum}(L_{on1}, L_{on2}, \dots L_{on9})}{\text{Maximum}(L_{on1}, L_{on2}, \dots L_{on9})} \times 100(\%)$$

Measuring point for surface luminance & measuring point for luminance variation

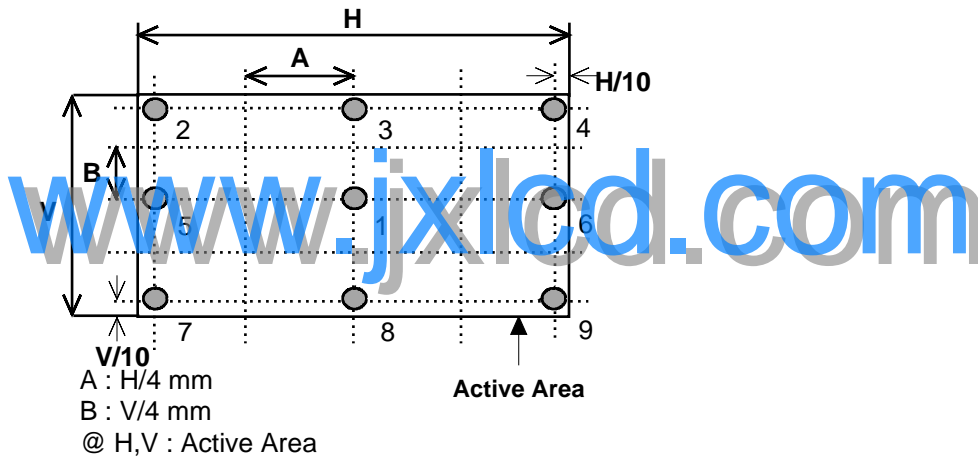

**FIG. 2 Measure Point for Luminance**

< Luminance Uniformity - angular – dependence (L<sub>R</sub>& T<sub>B</sub>)

TCO '03 Luminance uniformity – angular dependence, is the capacity of the VDU to present the same luminance level independently of the viewing direction. The angular-dependent luminance uniformity is calculated as the ratio of maximum luminance to minimum luminance in the specified measurement areas.

Test pattern : 80% white pattern

Test point : 2-point

Test distance : D \* 1.5 = 76.58cm

Test method :  $L_R = ((L_{\text{max.} +30\text{deg.}} / L_{\text{min.} +30\text{deg.}}) + (L_{\text{max.} -30\text{deg.}} / L_{\text{min.} -30\text{deg.}})) / 2$

$T_B = ((L_{\text{max.} +15\text{deg.}} / L_{\text{min.} +15\text{deg.}})$

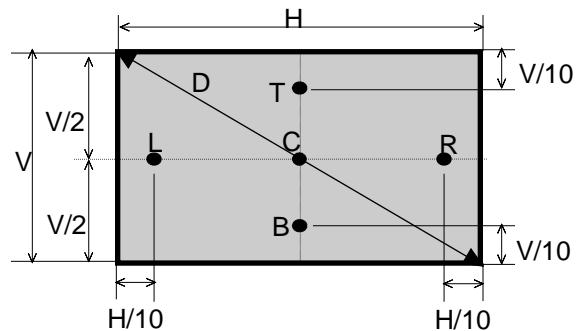

**FIG. 3 Measure Point for Luminance uniformity – angular dependence**

Product Specification

4. **The response time** is defined as the following figure and shall be measured by switching the input signal for "black" and "white".  
Response time is the time required for the display to transition from black to white (Rise Time,  $TrR$ ) and from white to black (Decay Time,  $TrD$ ).

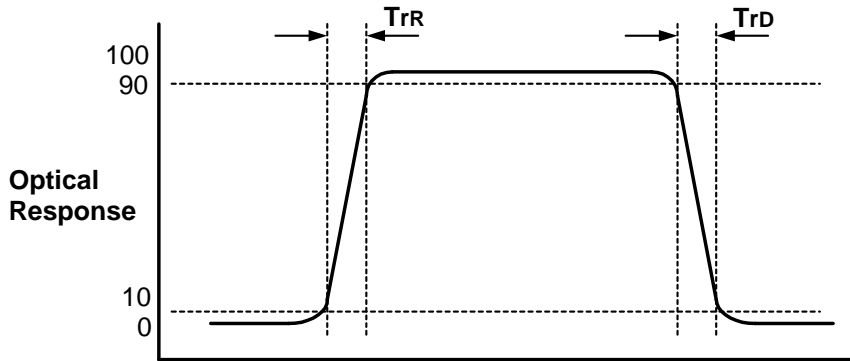

FIG. 4 Response Time

5. **The Gray to Gray response time** is defined as the following figure and shall be measured by switching the input signal for "Gray To Gray".
- Gray step : 5 Step
  - $T_{GTG\_AVR}$  is the total average time at rising time and falling time for "Gray To Gray".
  - $T_{GTG\_MAX}$  is the max time at rising time or falling time for "Gray To Gray".

Gray to Gray		Rising Time				
		G255	G191	G127	G63	G0
Falling Time	G255					
	G191					
	G127					
	G63					
	G0					

**Product Specification**

6. **Color shift** is the angle at which the color difference is lower than 0.04.

- Color difference (  $u'v'$  )

$$u' = \frac{4x}{-2x + 12y + 3}$$

$$v' = \frac{9y}{-2x + 12y + 3}$$

$$u'v' = \sqrt{(u'_1 - u'_2)^2 + (v'_1 - v'_2)^2}$$

$u'_1, v'_1$  :  $u'v'$  value at viewing angle direction

$u'_2, v'_2$  :  $u'v'$  value at front (  $\theta = 0$  )

- Pattern size : 25% Box size

- Viewing angle direction of color shift : Horizontal, Vertical

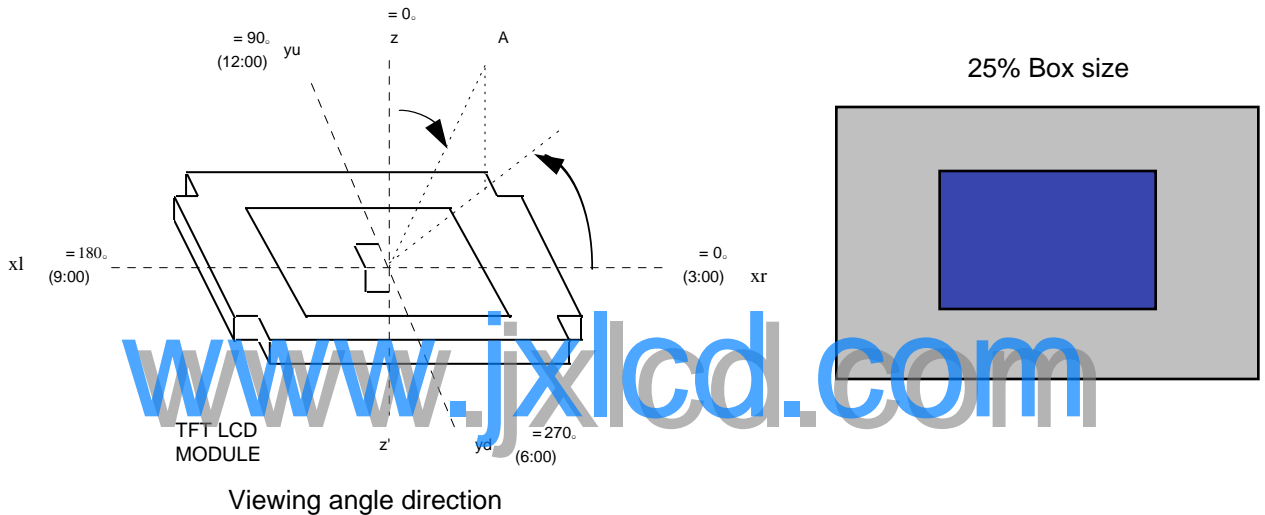

Average RGB values in Bruce RGB for Macbeth Chart

	Dark skin	Light skin	Blue sky	Foliage	Blue flower	Bluish green
R	98	206	85	77	129	114
G	56	142	112	102	118	199
B	45	123	161	46	185	178
	Orange	Purplish blue	Moderate red	Purple	Yellow green	Orange yellow
R	219	56	211	76	160	230
G	104	69	67	39	193	162
B	24	174	87	86	58	29
	Blue	Green	Red	Yellow	Magenta	cyan
R	26	72	197	241	207	35
G	32	148	27	212	62	126
B	145	65	37	36	151	172
	White	Neutral 8	Neutral 6.5	Neutral 5	Neutral 3.5	black
R	240	206	155	110	63	22
G	240	206	155	110	63	22
B	240	206	155	110	63	22

Product Specification

7. **Viewing angle(general)** is the angle at which the contrast ratio is greater than 10.

8. **Effective viewing angle** is the angle at which the gamma shift of gray scale is lower than 0.3.

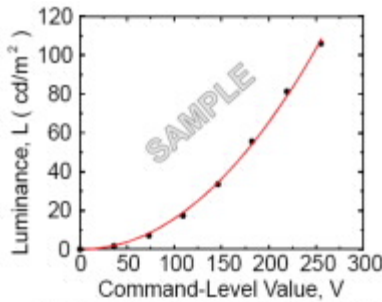

Fig. 1. Sample Luminance vs. gray scale (using a 256 bit gray scale).

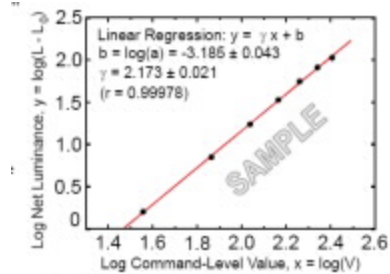

Fig. 2. Sample Log-log plot of luminance vs. gray scale.

$$L = aV^\gamma - L_b$$

$$\log(L - L_b) = \gamma \log(V) + \log(a)$$

FIG. 5

Here the Parameter  $\gamma$  and  $L_b$  relate the signal level V to the luminance L. The GAMMA we calculate from the log-log representation (Fig. 4)

9. Gray scale specification

Gamma Value is approximately 2.2. For more information see Table 10.

Table 10. Gray Scale Specification

Gray Level	Relative Luminance [%] (Typ.)
0	0.12
31	1.20
63	4.57
95	11.3
127	21.4
159	35.2
191	52.8
223	74.4
255	100



## Product Specification

## 5. Mechanical Characteristics

The contents provide general mechanical characteristics. In addition the figures in the next page are detailed mechanical drawing of the LCD.

Outside dimensions	Horizontal	432.0 +0.4/-0.3mm
	Vertical	331.5 ± 0.5mm
	Depth	25.0 ± 0.5 mm
Bezel area	Horizontal	413.0 mm
	Vertical	311.0 mm
Active display area	Horizontal	408.0 mm
	Vertical	306.0 mm
Weight (approximate)	3,200g (Typ.) / 3250g (Max)	
Surface Treatment	Hard coating (3H) Anti-glare treatment of the front polarizer Haze (25%)	

Notes : Please refer to a mechanic drawing in terms of tolerance at the next page.

Product Specification

<FRONT VIEW>

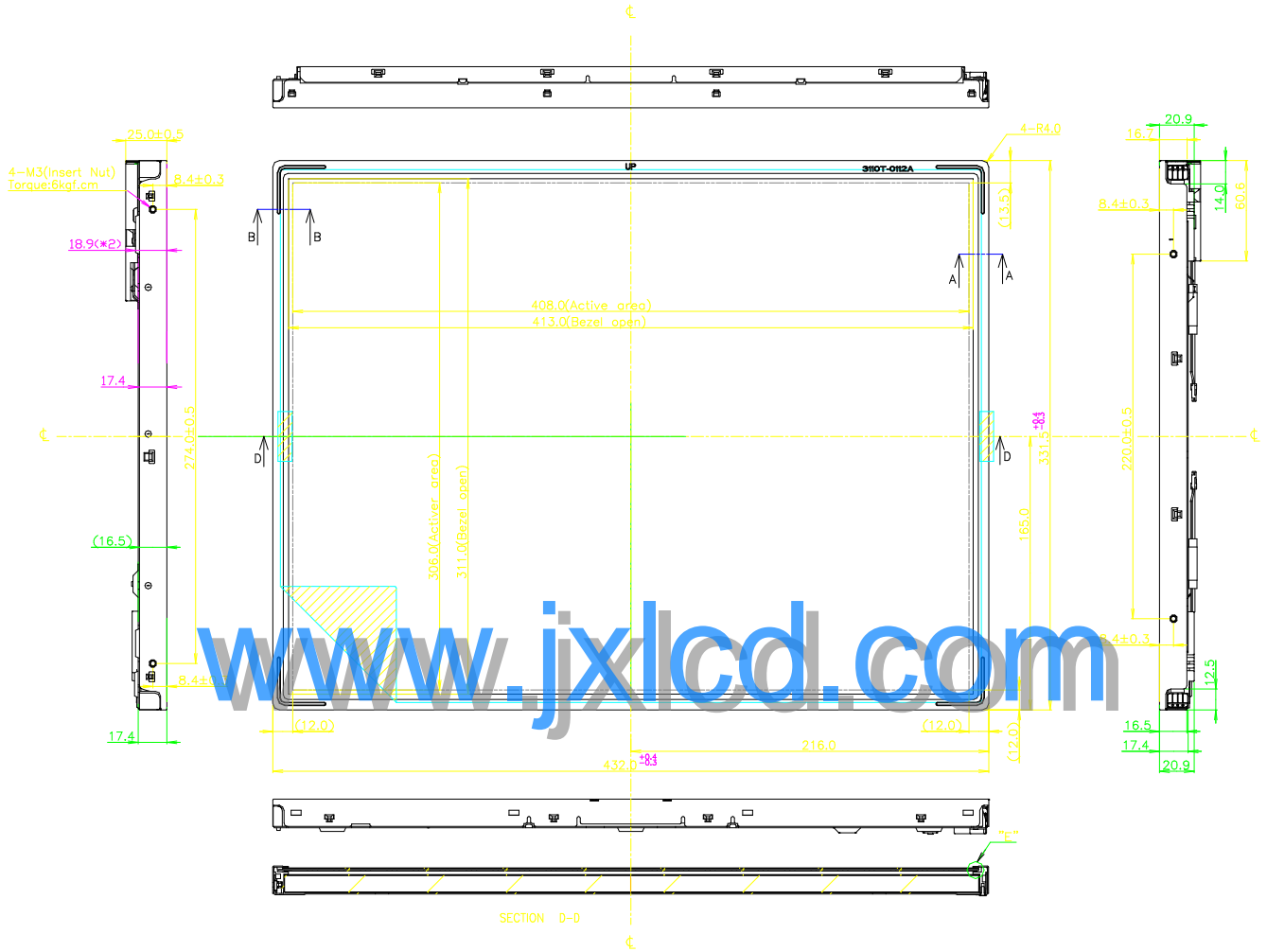

www.jxlcd.com

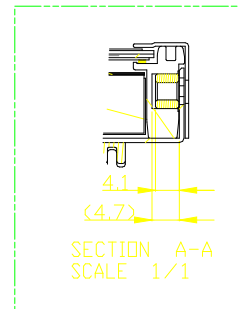
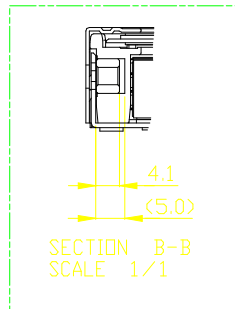
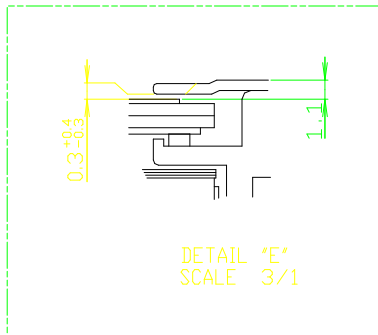

Product Specification

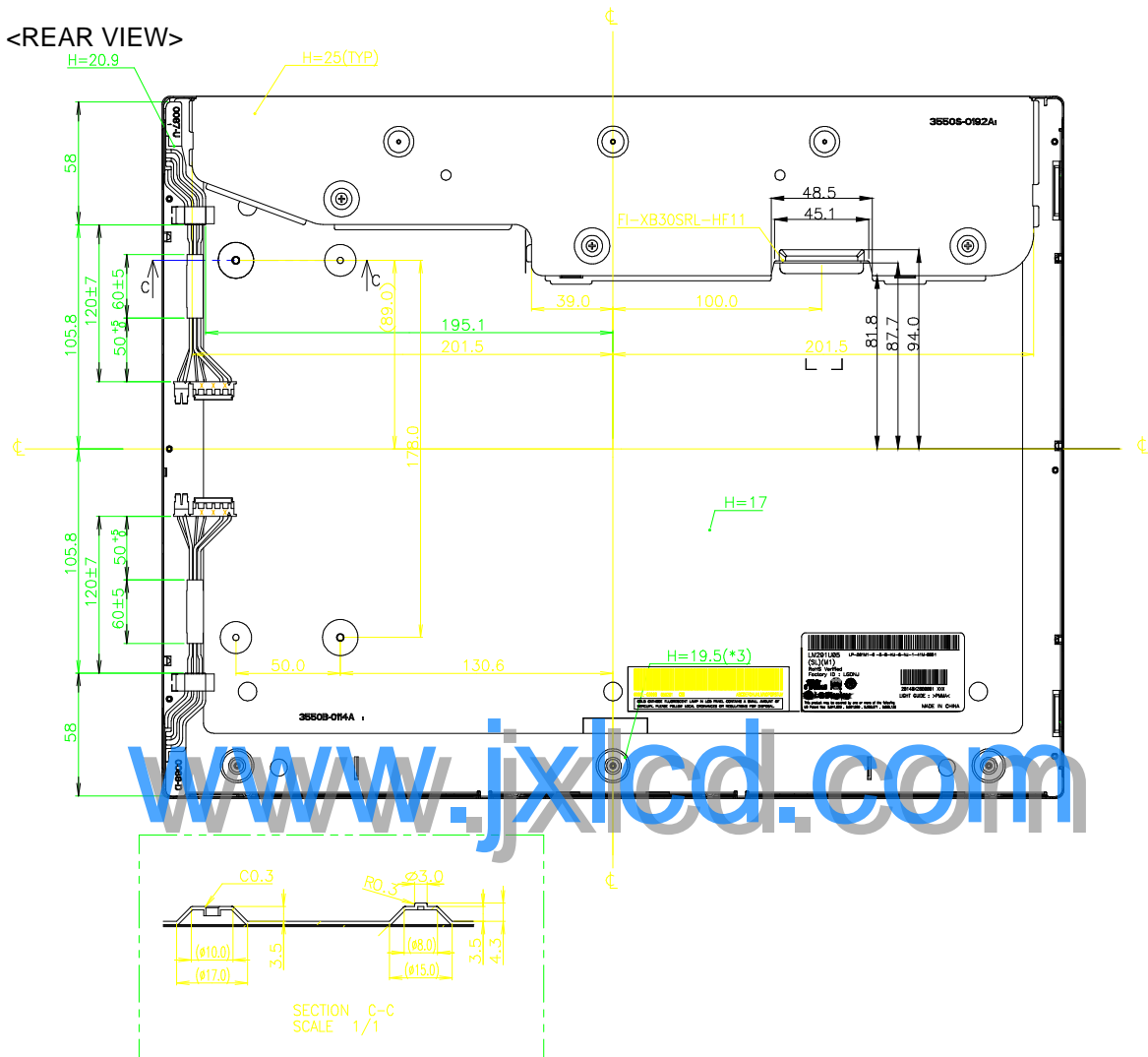

NOTES

1. Unspecified tolerances are to be  $\pm 0.5\text{mm}$ .
2. Both backlight wires and contraction tubes are excluded from outline dimensions.
3. Tilt and partial disposition tolerance of display area are as following.
  - (1) Y-Direction :  $|A-B| \leq 1.0\text{mm}$
  - (2) X-Direction :  $|C-D| \leq 1.0\text{mm}$
4. I/F Connector Specification : IS100-L30R-C23
5. Lamp Connector Specification
  - BHSR-02VS-1(JST)
  - BHR-05VS-1(JST)
6. Lamp(CCFL) lot No.is marked at backlight connector.

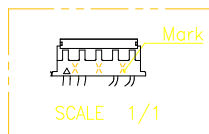
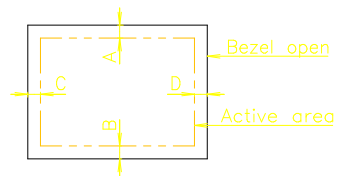

7. Do not wrap conductive tapes around the backlight wires.

## Product Specification

**6. Reliability**

Environment test condition

No	Test Item	Condition
1	High temperature storage test	Ta= 60°C 240h
2	Low temperature storage test	Ta= -20°C 240h
3	High temperature operation test	Ta= 50°C 50%RH 240h
4	Low temperature operation test	Ta= 0°C 240h
5	Vibration test (non-operating)	(NDS conditions) Wave form : random Vibration level : 1.43G RMS Bandwidth : 5-200Hz Duration : X,Y,Z, 33 min One time each direction
		(LPL conditions) Wave form : random Vibration level : 1.0G RMS Bandwidth : 10-500Hz Duration : X,Y,Z, 20 min One time each direction
6	Shock test (non-operating)	Shock level : 120G Waveform : half sine wave, 2ms Direction : ±X, ±Y, ±Z One time each direction
7	Altitude operating storage / shipment	0 - 10,000 feet(3048m) 0 - 40,000 feet(12,192m)

## Product Specification

## 7. International Standards

### 7-1. Safety

- a) UL 60950-1:2003, First Edition, Underwriters Laboratories, Inc., Standard for Safety of Information Technology Equipment.
- b) CAN/CSA C22.2, No. 60950-1-03 1<sup>st</sup> Ed. April 1, 2003, Canadian Standards Association, Standard for Safety of Information Technology Equipment.
- c) EN 60950-1:2001, First Edition, European Committee for Electrotechnical Standardization(CENELEC) European Standard for Safety of Information Technology Equipment.

### 7-2. EMC

- a) ANSI C63.4 "Methods of Measurement of Radio-Noise Emissions from Low-Voltage Electrical and Electrical Equipment in the Range of 9kHz to 40GHz. "American National Standards Institute(ANSI), 1992
- b) C.I.S.P.R "Limits and Methods of Measurement of Radio Interface Characteristics of Information Technology Equipment." International Special Committee on Radio Interference.
- c) EN 55022 "Limits and Methods of Measurement of Radio Interface Characteristics of Information Technology Equipment." European Committee for Electrotechnical Standardization.(CENELEC), 1998 ( Including A1: 2000 )

### 7-3. Environment

- a) RoHS, Directive 2002/95/EC of the European Parliament and of the Council on the reduction of the use of certain hazardous substances in electrical and electronic equipment, January 2003.

Product Specification

## 8. Packing

### 8-1. Designation of Lot Mark

a) Lot Mark

A	B	C	D	E	F	G	H	I	J	K	L	M
---	---	---	---	---	---	---	---	---	---	---	---	---

A,B,C : SIZE(INCH)  
E : MONTH

D : YEAR  
F ~ M : SERIAL NO.

Note

1. YEAR

Year	2001	2002	2003	2004	2005	2006	2007	2008	2009	2010
Mark	1	2	3	4	5	6	7	8	9	0

2. MONTH

Month	Jan	Feb	Mar	Apr	May	Jun	Jul	Aug	Sep	Oct	Nov	Dec
Mark	1	2	3	4	5	6	7	8	9	A	B	C

b) Location of Lot Mark

Serial No. is printed on the label. The label is attached to the backside of the LCD module.  
This is subject to change without prior notice.

**Product Specification**

**8-2. Packing Form**

- a) Package quantity in one box : 6EA
- b) Box Size : 525 X 314 X 410

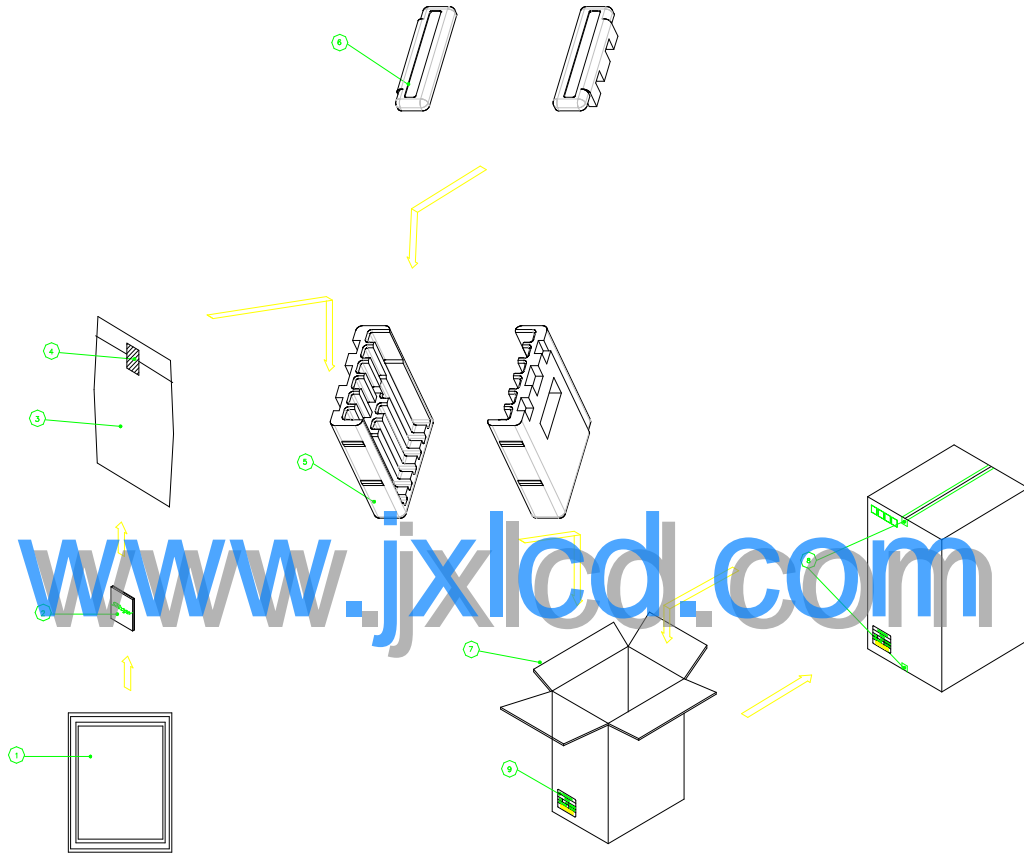

NO.	DESCRIPTION	MATERIAL
1	LCM	
2	SILICAGEL	60G, A TYPE
3	BAG	AL
4	TAPE	OPP
5	PACKING, BOTTOM	EPS
6	PACKING, TOP	EPS
7	BOX	PAPER, SW
8	TAPE	OPP
9	LABEL	ART

**8-3. Pallet Form**

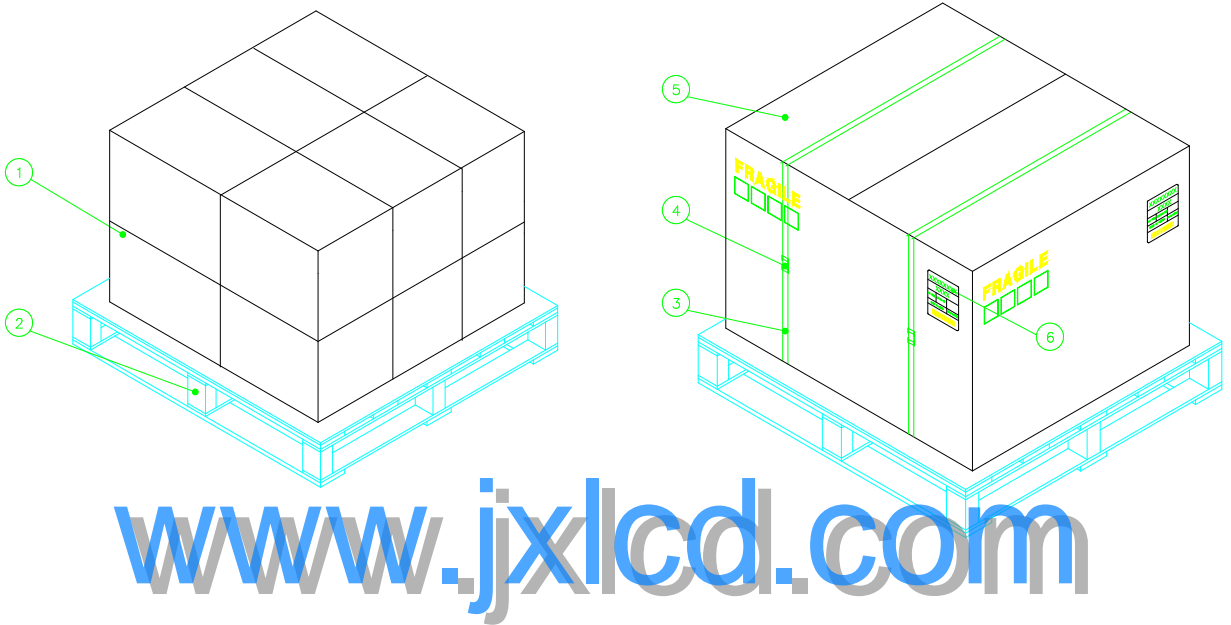

[www.jxlcd.com](http://www.jxlcd.com)

NO.	DESCRIPTION	MATERIAL
1	PACKING ASS'Y	
2	PALLET	PLYWOOD_1080X980X117.5
3	BAND	PP
4	BAND, CLIP	CLIP
5	ANGLE PACKING	PAPER, SW
6	LABEL	ART



## Product Specification

## 9. PRECAUTIONS

Please pay attention to the followings when you use this TFT LCD module.

### 9-1. MOUNTING PRECAUTIONS

- (1) You must mount a module using holes arranged in four corners or four sides.
- (2) You should consider the mounting structure so that uneven force (ex. Twisted stress) is not applied to the module. And the case on which a module is mounted should have sufficient strength so that external force is not transmitted directly to the module.
- (3) Please attach the surface transparent protective plate to the surface in order to protect the polarizer. Transparent protective plate should have sufficient strength in order to resist external force.
- (4) You should adopt radiation structure to satisfy the temperature specification.
- (5) Acetic acid type and chlorine type materials for the cover case are not desirable because the former generates corrosive gas of attacking the polarizer at high temperature and the latter causes circuit break by electro-chemical reaction.
- (6) Do not touch, push or rub the exposed polarizers with glass, tweezers or anything harder than HB pencil lead. And please do not rub with dust clothes with chemical treatment. Do not touch the surface of polarizer for bare hand or greasy cloth. (Some cosmetics are detrimental to the polarizer.)
- (7) When the surface becomes dusty, please wipe gently with absorbent cotton or other soft materials like chamois soaks with petroleum benzene. Normal hexane is recommended for cleaning the adhesives used to attach front / rear polarizers. Do not use acetone, toluene and alcohol because they cause chemical damage to the polarizer.
- (8) Wipe off saliva or water drops as soon as possible. Their long time contact with polarizer causes deformations and color fading.

### 9-2. OPERATING PRECAUTIONS

- (9) Do not open the case because IC circuits do not have sufficient strength.
- (1) The spike noise causes the mis-operation of circuits. It should be lower than following voltage :  
 $V = \pm 200\text{mV}$  (Over and under shoot voltage)
- (2) Response time depends on the temperature. (In lower temperature, it becomes longer.)
- (3) Brightness depends on the temperature. (In lower temperature, it becomes lower.)  
 And in lower temperature, response time (required time that brightness is stable after turned on) becomes longer.
- (4) Be careful for condensation at sudden temperature change. Condensation makes damage to polarizer or electrical contacted parts. And after fading condensation, smear or spot will occur.
- (5) When fixed patterns are displayed for a long time, remnant image is likely to occur.
- (6) Module has high frequency circuits. Sufficient suppression to the electromagnetic interference shall be done by system manufacturers. Grounding and shielding methods may be important to minimized the interference.
- (7) Please do not give any mechanical and/or acoustical impact to LCM. Otherwise, LCM can not be operated its full characteristics perfectly.
- (8) A screw which is fastened up the steels should be a machine screw (if not, it causes metallic foreign material and deal LCM a fatal blow)
- (9) Please do not set LCD on its edge.

**Product Specification****9-3. ELECTROSTATIC DISCHARGE CONTROL**

Since a module is composed of electronic circuits, it is not strong to electrostatic discharge. Make certain that treatment persons are connected to ground through wrist band etc. And don't touch interface pin directly.

**9-4. PRECAUTIONS FOR STRONG LIGHT EXPOSURE**

Strong light exposure causes degradation of polarizer and color filter.

**9-5. STORAGE**

When storing modules as spares for a long time, the following precautions are necessary.

- (1) Store them in a dark place. Do not expose the module to sunlight or fluorescent light. Keep the temperature between 5°C and 35°C at normal humidity.
- (2) The polarizer surface should not come in contact with any other object.  
It is recommended that they be stored in the container in which they were shipped.

**9-6. HANDLING PRECAUTIONS FOR PROTECTION FILM**

- (1) The protection film is attached to the bezel with a small masking tape.  
When the protection film is peeled off, static electricity is generated between the film and polarizer. This should be peeled off slowly and carefully by people who are electrically grounded and with well ion-blown equipment or in such a condition, etc.
- (2) When the module with protection film attached is stored for a long time, sometimes there remains a very small amount of glue still on the bezel after the protection film is peeled off.
- (3) You can remove the glue easily. When the glue remains on the bezel surface or its vestige is recognized, please wipe them off with absorbent cotton waste or other soft material like chamois soaked with normal-hexane.