



LM201WE3  
Liquid Crystal Display

Product Specification

## SPECIFICATION FOR APPROVAL

- ( ) Preliminary Specification  
( ● ) Final Specification

Title	20.1" WSXGA+ TFT LCD
-------	----------------------

BUYER	Apple
MODEL	

SUPPLIER	LG. Display Co., Ltd.
*MODEL	LM201WE3
SUFFIX	TLF8

\*When you obtain standard approval,  
please use the above model name without suffix

APPROVED BY	SIGNATURE	DATE
/	_____	_____
/	_____	_____
/	_____	_____

Please return 1 copy for your confirmation with  
your signature and comments.

APPROVED BY	SIGNATURE	DATE
Hans. Kim / G. Manager	_____	_____
<b>REVIEWED BY</b>		
Tomi. Jung / Manager	_____	_____
<b>PREPARED BY</b>		
S.H. Kim / Engineer	_____	_____

**MNT Products Engineering Dept.**  
**LG. Display Co., Ltd**

## Product Specification

Contents

No	ITEM	Page
	COVER	1
	CONTENTS	2
	RECORD OF REVISIONS	3
1	GENERAL DESCRIPTION	4
2	ABSOLUTE MAXIMUM RATINGS	5
3	ELECTRICAL SPECIFICATIONS	6
3-1	ELECTRICAL CHARACTERISTICS	6
3-2	INTERFACE CONNECTIONS	9
3-3	SIGNAL TIMING SPECIFICATIONS	13
3-4	SIGNAL TIMING WAVEFORMS	14
3-5	COLOR INPUT DATA REFERNECE	15
3-6	POWER SEQUENCE	16
4	OPTICAL SPECIFICATIONS	17
5	MECHANICAL CHARACTERISTICS	22
6	RELIABILITY	25
7	INTERNATIONAL STANDARDS	26
7-1	SAFETY	26
7-2	EMC	26
8	PACKING	27
8-1	DESIGNATION OF LOT MARK	27
8-2	PACKING FORM	27
9	PRECAUTIONS	28
10	EDID DATA FOR LM201WE3-TLF7	30



LM201WE3  
Liquid Crystal Display

Product Specification

**RECORD OF REVISIONS**

Revision No	Revision Date	Page	DESCRIPTION
0.0	Oct. 15. 2008	-	Preliminary Specification of LM201WE3-TLF8
1.0	Dec. 03. 2008	-	Final Specification of LM201WE3-TLF8

## Product Specification

## 1. General Description

LM201WE3 is a Color Active Matrix Liquid Crystal Display with an integral Cold Cathode Fluorescent Lamp(CCFL) backlight system. The matrix employs a-Si Thin Film Transistor as the active element. It is a transmissive type display operating in the normally white mode. It has a 20.1 inch diagonally measured active display area with WSXGA+ resolution (1050 vertical by 1680 horizontal pixel array). Each pixel is divided into Red, Green and Blue sub-pixels or dots which are arranged in vertical stripes. Gray scale or the brightness of the sub-pixel color is determined with a 8-bit gray scale signal for each dot, thus, presenting a palette of more than 16,7M colors with A-FRC(Advanced Frame Rate Control). It has been designed to apply the 8Bit 2 port LVDS interface. It is intended to support displays where high brightness, super wide viewing angle, high color saturation, and high color are important.

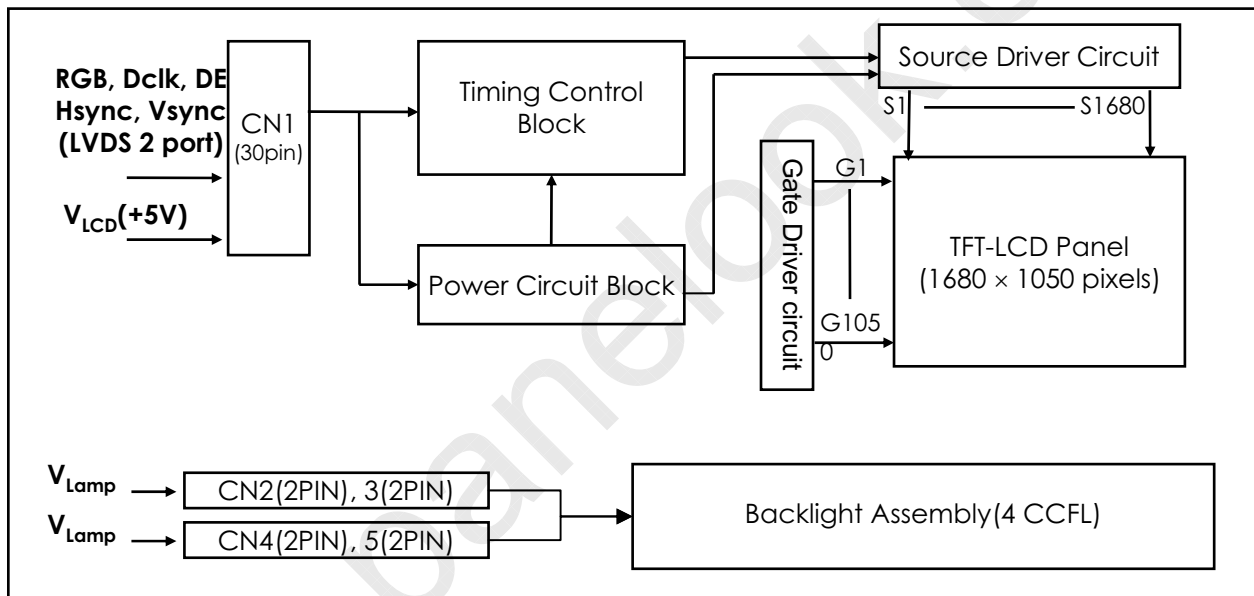

## General Features

Active Screen Size	20.1 inches(511.133mm) diagonal (Aspect ratio 16:10)
Outline Dimension	459.4(H) x 296.4 (V) x 14.5(D) mm (Typ.)
Pixel Pitch	0.258mm x 0.258mm
Pixel Format	1680 horiz. By 1050 vert. Pixels RGB strip arrangement
Color Depth	16.7 M colors
Luminance, White	300 cd/m <sup>2</sup> (5 points Avg.)
Viewing Angle (CR>10)	Viewing Angle Free ( R/L 160(Typ.), U/D 160(Typ) )
Power Consumption	Total 25.21 Watt(Typ.) (3.91 Watt@V <sub>LCD</sub> , 21.3 Watt@300cd/[LAMP=7.0mA])
Weight	2050 g (Typ.)
Display Operating Mode	Transmissive mode, Normally White
Surface Treatment	Hard coating (2H), Glare treatment of the front polarizer

## Product Specification

## 2. Absolute Maximum Ratings

The following are maximum values which, if exceeded, may cause faulty operation or damage to the unit.

**Table 1. ABSOLUTE MAXIMUM RATINGS**

Parameter	Symbol	Values		Units	Notes
		Min	Max		
Power Input Voltage	VLCD	-0.3	+5.5	Vdc	at 25 ± 2 °C
Operating Temperature	T <sub>OP</sub>	0	50	°C	1
Storage Temperature	T <sub>ST</sub>	-20	60	°C	1
Operating Ambient Humidity	H <sub>OP</sub>	10	90	%RH	1
Storage Humidity	H <sub>ST</sub>	10	90	%RH	1

Note : 1. Temperature and relative humidity range are shown in the figure below.  
 Wet bulb temperature should be 39 °C Max, and no condensation of water.

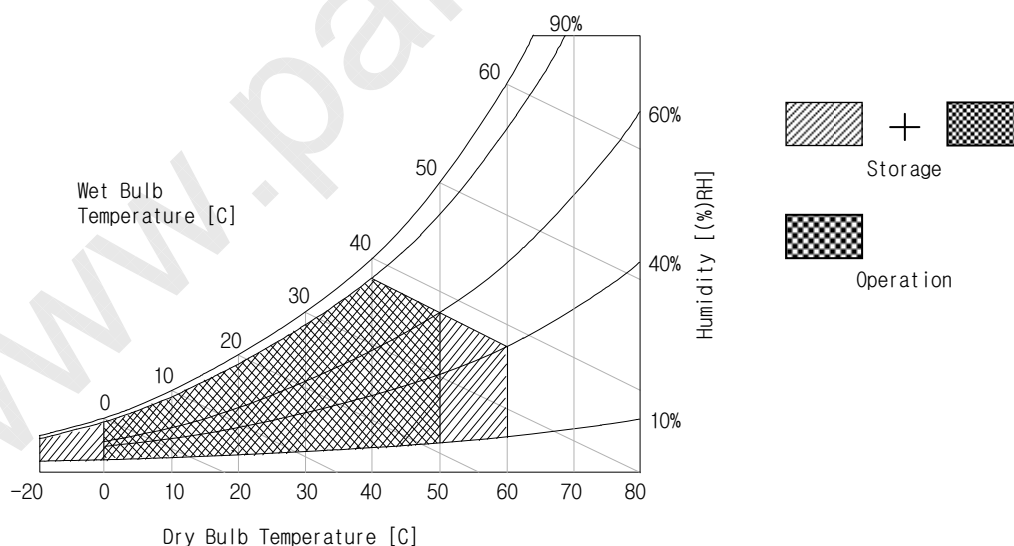

## Product Specification

### 3. Electrical Specifications

#### 3-1. Electrical Characteristics

It requires two power inputs. One is employed to power the LCD electronics and to drive the TFT array and liquid crystal. The second input power for the CCFL, is typically generated by an inverter. The inverter is an external unit to the LCDs.

**Table 2\_1. ELECTRICAL CHARACTERISTICS**

Parameter	Symbol	Values			Unit	Notes
		Min	Typ	Max		
MODULE :						
Power Supply Input Voltage	V <sub>LCD</sub>	4.5	5.0	5.5	Vdc	
Power Supply Input Current	I <sub>LCD</sub>	-	781	899	mA	1
		-	976	1269	mA	2
Power Consumption	P <sub>LCD</sub>	-	3.91	4.50	Watt	1
Rush current	I <sub>RUSH</sub>	-	-	3	A	3

Note :

1. The specified current and power consumption are under the  $V_{LCD}=5.0V$ ,  $25 \pm 2^{\circ}C$ ,  $f_V=60Hz$  condition whereas mosaic pattern(8 x 6) is displayed and  $f_V$  is the frame frequency.
2. The current is specified at the maximum current pattern.
3. The duration of rush current is about 2ms and rising time of power Input is  $500us \pm 20\%$ .(min.).

White : 255Gray  
 Black : 0Gray

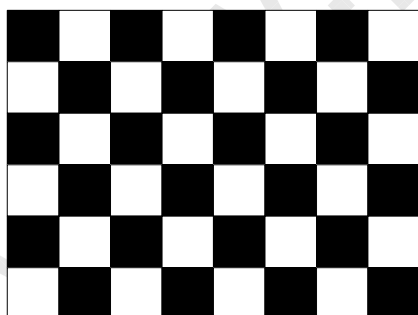

Mosaic Pattern(8 x 6)

Maximum current pattern

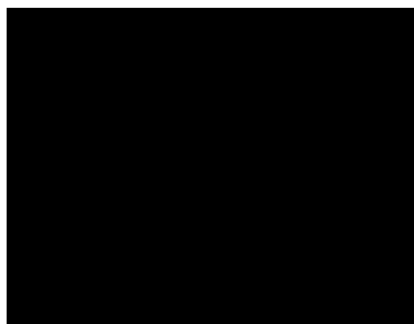

Black Pattern

## Product Specification

Table 2\_2. ELECTRICAL CHARACTERISTICS

Parameter	Symbol	Values			Unit	Notes
		Min	Typ	Max		
LAMP :						
Operating Voltage	V <sub>BL</sub>	725(8.0mA)	760(7.0mA)	920(2.5mA)	V <sub>RMS</sub>	1, 2
Operating Current	I <sub>BL</sub>	2.5	7.0	8.0	mA <sub>RMS</sub>	1
Established Starting Voltage	V <sub>s</sub>					1, 3
	at 25 °C			1250	V <sub>RMS</sub>	
	at 0 °C			1550	V <sub>RMS</sub>	
Operating Frequency	f <sub>BL</sub>	40	60	70	kHz	4
Discharge Stabilization Time	T <sub>s</sub>			3	Min	1, 5
Power Consumption	P <sub>BL</sub>		21.3	23.43	Watt	6
Life Time		50,000			Hrs	1, 7

Note : The design of the inverter must have specifications for the lamp in LCD Assembly.

The performance of the Lamp in LCM, for example life time or brightness, is extremely influenced by the characteristics of the DC-AC inverter. So all the parameters of an inverter should be carefully designed so as not to produce too much leakage current from high-voltage output of the inverter.

When you design or order the inverter, please make sure unwanted lighting caused by the mismatch of the lamp and the inverter (no lighting, flicker, etc) never occurs. When you confirm it, the LCD-Assembly should be operated in the same condition as installed in you instrument.

※ Do not attach a conducting tape to lamp connecting wire.

If the lamp wire attach to a conducting tape, TFT-LCD Module has a low luminance and the inverter has abnormal action. Because leakage current is occurred between lamp wire and conducting tape.

- Specified values are for a single lamp.
- Operating voltage is measured at  $25 \pm 2^\circ\text{C}$ . The variance of the voltage is  $\pm 10\%$ .
- The voltage above  $V_s$  should be applied to the lamps for more than 1 second for start-up.  
(Inverter open voltage must be more than lamp starting voltage.)  
Otherwise, the lamps may not be turned on. The used lamp current is the lamp typical current.
- Lamp frequency may produce interface with horizontal synchronous frequency and as a result this may cause beat on the display. Therefore lamp frequency shall be as away possible from the horizontal synchronous frequency and from its harmonics in order to prevent interference.
- Let's define the brightness of the lamp after being lighted for 5 minutes as 100%.  
 $T_s$  is the time required for the brightness of the center of the lamp to be not less than 95%.
- The lamp power consumption shown above does not include loss of external inverter.  
The used lamp current is the lamp typical current. ( $P_{BL} = V_{BL} \times I_{BL} \times N_{Lamp}$ )
- The life is determined as the time at which brightness of the lamp is 50% compared to that of initial value at the typical lamp current on condition of continuous operating at  $25 \pm 2^\circ\text{C}$ .

## Product Specification

8. The output of the inverter must have symmetrical(negative and positive) voltage waveform and symmetrical current waveform (Unsymmetrical ratio is less than 10%). Please do not use the inverter which has unsymmetrical voltage and unsymmetrical current and spike wave. Requirements for a system inverter design, which is intended to have a better display performance, a better power efficiency and a more reliable lamp, are following.

It shall help increase the lamp lifetime and reduce leakage current.

- The asymmetry rate of the inverter waveform should be less than 10%.
- The distortion rate of the waveform should be within  $\sqrt{2} \pm 10\%$ .

\* Inverter output waveform had better be more similar to ideal sine wave.

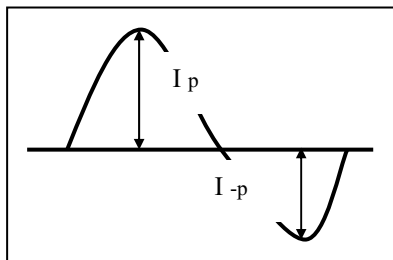

\* Asymmetry rate:

$$\frac{|I_p - I_{-p}|}{I_{rms}} \times 100\%$$

\* Distortion rate

$$I_p \text{ (or } I_{-p}) / I_{rms}$$

9. The inverter which is combined with this LCM, is highly recommended to connect coupling(ballast) condenser at the high voltage output side. When you use the inverter which has not coupling(ballast) condenser, it may cause abnormal lamp lighting because of biased mercury as time goes.
10. In case of edgy type back light with over 4 parallel lamps, input current and voltage wave form should be synchronized



## Product Specification

### 3-2. Interface Connections

—LCD Connector(CN1) : FI-XB30SRL-HF11 (Manufactured by JAE)

—Mating Connector : FI-X30C2L (Manufactured by JAE) or equivalent.

**Table 3. MODULE CONNECTOR(CN1) PIN CONFIGURATION**

Pin No	Symbol	Description	
1	FR0M	Minus signal of odd channel 0 (LVDS)	First data
2	FR0P	Plus signal of odd channel 0 (LVDS)	
3	FR1M	Minus signal of odd channel 1 (LVDS)	
4	FR1P	Plus signal of odd channel 1 (LVDS)	
5	FR2M	Minus signal of odd channel 2 (LVDS)	
6	FR2P	Plus signal of odd channel 2 (LVDS)	
7	GND	Ground	
8	FCLKINM	Minus signal of odd clock channel (LVDS)	
9	FCLKINP	Plus signal of odd clock channel (LVDS)	
10	FR3M	Minus signal of odd channel 3 (LVDS)	
11	FR3P	Plus signal of odd channel 3 (LVDS)	
12	SR0M	Minus signal of even channel 0 (LVDS)	Second data
13	SR0P	Plus signal of even channel 0 (LVDS)	
14	GND	Ground	
15	SR1M	Minus signal of even channel 1 (LVDS)	
16	SR1P	Plus signal of even channel 1 (LVDS)	
17	GND	Ground	
18	SR2M	Minus signal of even channel 2 (LVDS)	
19	SR2P	Plus signal of even channel 2 (LVDS)	
20	SCLKINM	Minus signal of even clock channel (LVDS)	
21	SCLKINP	Plus signal of even clock channel (LVDS)	
22	SR3M	Minus signal of even channel 3 (LVDS)	
23	SR3P	Plus signal of even channel 3 (LVDS)	
24	GND	Ground	
25	CLK_EDID	EEPROM for CLK_EDID	
26	DATA_EDID	EEPROM for DATA_EDID	
27	V_EDID	EEPROM for V_EDID (3.3V)	
28	V <sub>LCD</sub>	Power Supply +5.0V	
29	V <sub>LCD</sub>	Power Supply +5.0V	
30	V <sub>LCD</sub>	Power Supply +5.0V	

- Note:
1. All GND(ground) pins should be connected together and to Vss which should also be connected to the LCD's metal frame.
  2. All V<sub>LCD</sub> (power input) pins should be connected together.
  3. Input Level of LVDS signal is based on the IEA 664 Standard.

Product Specification

User Connector Diagram

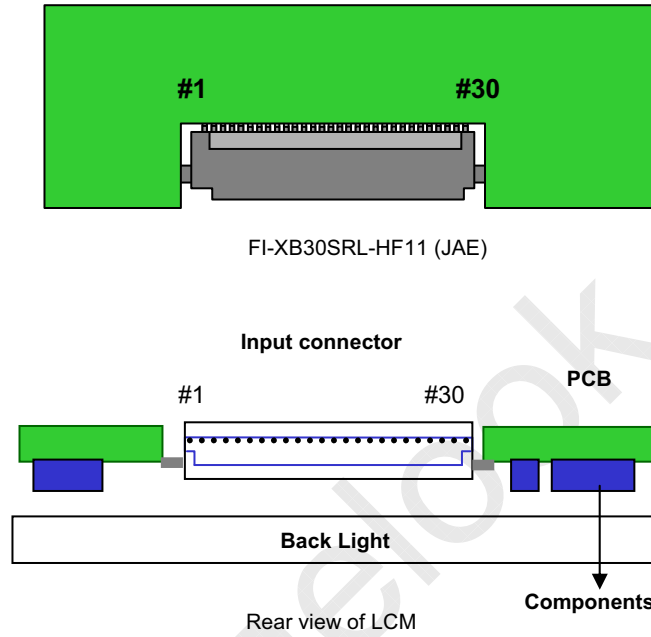

## Product Specification

**Table 4. REQUIRED SIGNAL ASSIGNMENT FOR Flat Link (TI:SN75LVDS83) Transmitter**

Pin #	Pin Name	Require Signal	Pin #	Pin Name	Require Signal
1	Vcc	Power Supply for TTL Input	29	GND	Ground pin for TTL
2	D5	TTL Input (R7)	30	D26	TTL Input (DE)
3	D6	TTL Input (R5)	31	T <sub>x</sub> CLKIN	TTL Level clock Input
4	D7	TTL Input (G0)	32	PWR DWN	Power Down Input
5	GND	Ground pin for TTL	33	PLL GND	Ground pin for PLL
6	D8	TTL Input (G1)	34	PLL Vcc	Power Supply for PLL
7	D9	TTL Input (G2)	35	PLL GND	Ground pin for PLL
8	D10	TTL Input (G6)	36	LVDS GND	Ground pin for LVDS
9	Vcc	Power Supply for TTL Input	37	TxOUT3 +	Positive LVDS differential data output 3
10	D11	TTL Input (G7)	38	TxOUT3 -	Negative LVDS differential data output 3
11	D12	TTL Input (G3)	39	T <sub>x</sub> CLKOUT +	Positive LVDS differential clock output
12	D13	TTL Input (G4)	40	T <sub>x</sub> CLKOUT -	Negative LVDS differential clock output
13	GND	Ground pin for TTL	41	T <sub>x</sub> OUT2 +	Positive LVDS differential data output 2
14	D14	TTL Input (G5)	42	T <sub>x</sub> OUT2 -	Negative LVDS differential data output 2
15	D15	TTL Input (B0)	43	LVDS GND	Ground pin for LVDS
16	D16	TTL Input (B6)	44	LVDS Vcc	Power Supply for LVDS
17	Vcc	Power Supply for TTL Input	45	T <sub>x</sub> OUT1 +	Positive LVDS differential data output 1
18	D17	TTL Input (B7)	46	T <sub>x</sub> OUT1 -	Negative LVDS differential data output 1
19	D18	TTL Input (B1)	47	T <sub>x</sub> OUT0 +	Positive LVDS differential data output 0
20	D19	TTL Input (B2)	48	T <sub>x</sub> OUT0 -	Negative LVDS differential data output 0
21	GND	Ground pin for TTL Input	49	LVDS GND	Ground pin for LVDS
22	D20	TTL Input (B3)	50	D27	TTL Input (R6)
23	D21	TTL Input (B4)	51	D0	TTL Input (R0)
24	D22	TTL Input (B5)	52	D1	TTL Input (R1)
25	D23	TTL Input (RSVD)	53	GND	Ground pin for TTL
26	Vcc	Power Supply for TTL Input	54	D2	TTL Input (R2)
27	D24	TTL Input (HSYNC)	55	D3	TTL Input (R3)
28	D25	TTL Input (VSYNC)	56	D4	TTL Input (R4)

Notes : Refer to LVDS Transmitter Data Sheet for detail descriptions.

## Product Specification

**Table 5. BACKLIGHT CONNECTOR PIN CONFIGURATION(CN2,CN3,CN4,CN5)**

The backlight interface connector is a model BHSR-02VS-2(or 1674817-1:manufactured by AMP)(CN2/CN3 /CN4/CN5) manufactured by JST. The mating connector part number are SM02B-BHSS-1-TB(2pin) or equivalent. The pin configuration for the connector is shown in the table below.

Pin	Symbol	Description	NOTES
1	HV	High Voltage for Lamp	1
2	LV	Low Voltage for Lamp	2

Note : 1. The high voltage power terminal is colored Gray, Sky blue.  
 2. The low voltage pin color is Black, Blue.

**<BACKLIGHT CONNECTOR DIAGRAM>**
**Up Side**

**Down Side**

## Product Specification

### 3-3. Signal Timing Specifications

This is the signal timing required at the input of the User connector. All of the interface signal timing should be satisfied with the following specifications for its proper operation.

**Table 6. Timing Table**

ITEM	Symbol		Min	Typ	Max	Unit	Note
DCLK	Period	tCLK	16.8	16.8	16.8	ns	2pixel/clock
	Frequency	-	59.5	59.5	59.5	MHz	
Hsync	Period	tHP	920	920	920	tCLK	
	Frequency	fH	64.674	64.674	64.674	KHz	
	Width	tWH	16	16	16	tCLK	
Vsync	Period	tVP	1080	1080	1080	tHP	
	Frequency	fV	60	60	60	Hz	
	Width	tWV	6	6	6	tHP	
DE (Data Enable)	Horizontal Valid	tHV	840	840	840	tCLK	
	Horizontal Back Porch	tHBP	40	40	40		
	Horizontal Front Porch	tHFP	24	24	24		
	Horizontal Blank	-	80	80	80		
	Vertical Valid	tVH	1050	1050	1050	tHP	
	Vertical Back Porch	tVBP	21	21	21		
	Vertical Front Porch	tVFP	3	3	3		
	Vertical Blank	-	30	30	30		

Notes: Hsync period and Hsync width-active should be even number times of tCLK. If the value is odd number times of tCLK, display control signal can be asynchronous. In order to operate this LCM a Hsync, Vsync, and DE(data enable) signals should be used.

1. The performance of the electro-optical characteristics may be influenced by variance of the vertical refresh rates.
2. Vsync and Hsync should be keep the above specification.
3. Hsync Period, Hsync Width, and Horizontal Back Porch should be any times of character number(8).
4. The polarity of Hsync, Vsync is not restricted.

### 3-4. Signal Timing Waveforms

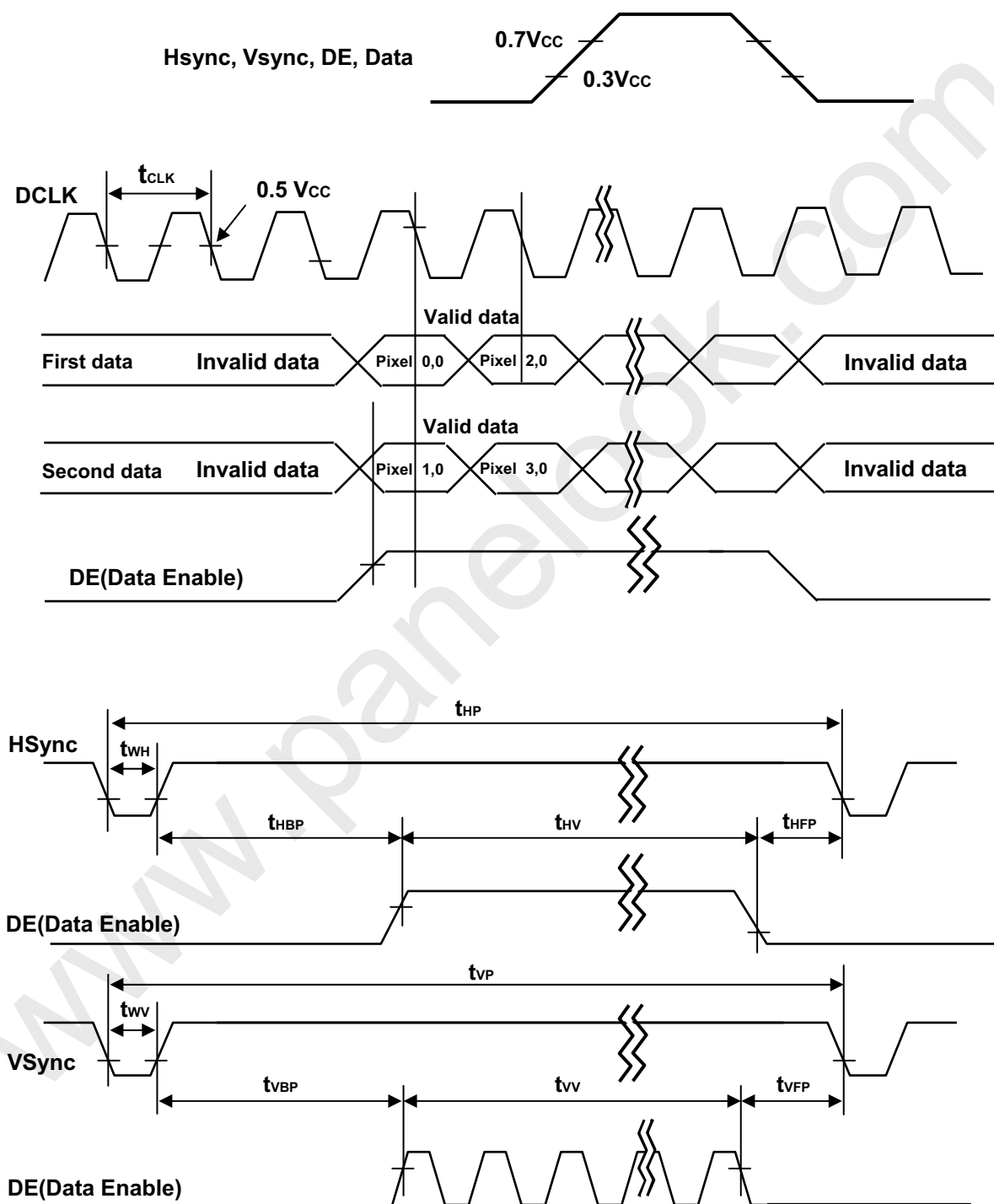



LM201WE3  
Liquid Crystal Display

Product Specification

### 3-5. Color Data Reference

The Brightness of each primary color(red,green,blue) is based on the 8-bit gray scale data input for the color; the higher the binary input, the brighter the color. The table below provides a reference for color versus data input.

Table 7. COLOR DATA REFERENCE

Color		Input Color Data																							
		RED								GREEN								BLUE							
		MSB				LSB				MSB				LSB				MSB				LSB			
		R7	R6	R5	R4	R3	R2	R1	R0	G7	G6	G5	G4	G3	G2	G1	G0	B7	B6	B5	B4	B3	B2	B1	B0
Basic Color	Black	0	0	0	0	0	0	0	0	0	0	0	0	0	0	0	0	0	0	0	0	0	0	0	0
	Red (255)	1	1	1	1	1	1	1	1	0	0	0	0	0	0	0	0	0	0	0	0	0	0	0	0
	Green (255)	0	0	0	0	0	0	0	0	1	1	1	1	1	1	1	1	0	0	0	0	0	0	0	0
	Blue (255)	0	0	0	0	0	0	0	0	0	0	0	0	0	0	0	0	1	1	1	1	1	1	1	1
	Cyan	0	0	0	0	0	0	0	0	1	1	1	1	1	1	1	1	1	1	1	1	1	1	1	1
	Magenta	1	1	1	1	1	1	1	1	0	0	0	0	0	0	0	0	1	1	1	1	1	1	1	1
	Yellow	1	1	1	1	1	1	1	1	1	1	1	1	1	1	1	1	0	0	0	0	0	0	0	0
	White	1	1	1	1	1	1	1	1	1	1	1	1	1	1	1	1	1	1	1	1	1	1	1	1
RED	RED (000) Dark	0	0	0	0	0	0	0	0	0	0	0	0	0	0	0	0	0	0	0	0	0	0	0	0
	RED (001)	0	0	0	0	0	0	0	1	0	0	0	0	0	0	0	0	0	0	0	0	0	0	0	0
	...	...								...								...							
	RED (254)	1	1	1	1	1	1	1	0	0	0	0	0	0	0	0	0	0	0	0	0	0	0	0	0
	RED (255)	1	1	1	1	1	1	1	1	0	0	0	0	0	0	0	0	0	0	0	0	0	0	0	0
GREEN	GREEN (000) Dark	0	0	0	0	0	0	0	0	0	0	0	0	0	0	0	0	0	0	0	0	0	0	0	0
	GREEN (001)	0	0	0	0	0	0	0	0	0	0	0	0	0	0	0	1	0	0	0	0	0	0	0	0
	...	...								...								...							
	GREEN (254)	0	0	0	0	0	0	0	0	1	1	1	1	1	1	1	0	0	0	0	0	0	0	0	0
	GREEN (255)	0	0	0	0	0	0	0	0	1	1	1	1	1	1	1	1	0	0	0	0	0	0	0	0
BLUE	BLUE (000) Dark	0	0	0	0	0	0	0	0	0	0	0	0	0	0	0	0	0	0	0	0	0	0	0	0
	BLUE (001)	0	0	0	0	0	0	0	0	0	0	0	0	0	0	0	0	0	0	0	0	0	0	0	1
	...	...								...								...							
	BLUE (254)	0	0	0	0	0	0	0	0	0	0	0	0	0	0	0	0	1	1	1	1	1	1	1	0
	BLUE (255)	0	0	0	0	0	0	0	0	0	0	0	0	0	0	0	0	1	1	1	1	1	1	1	1

## Product Specification

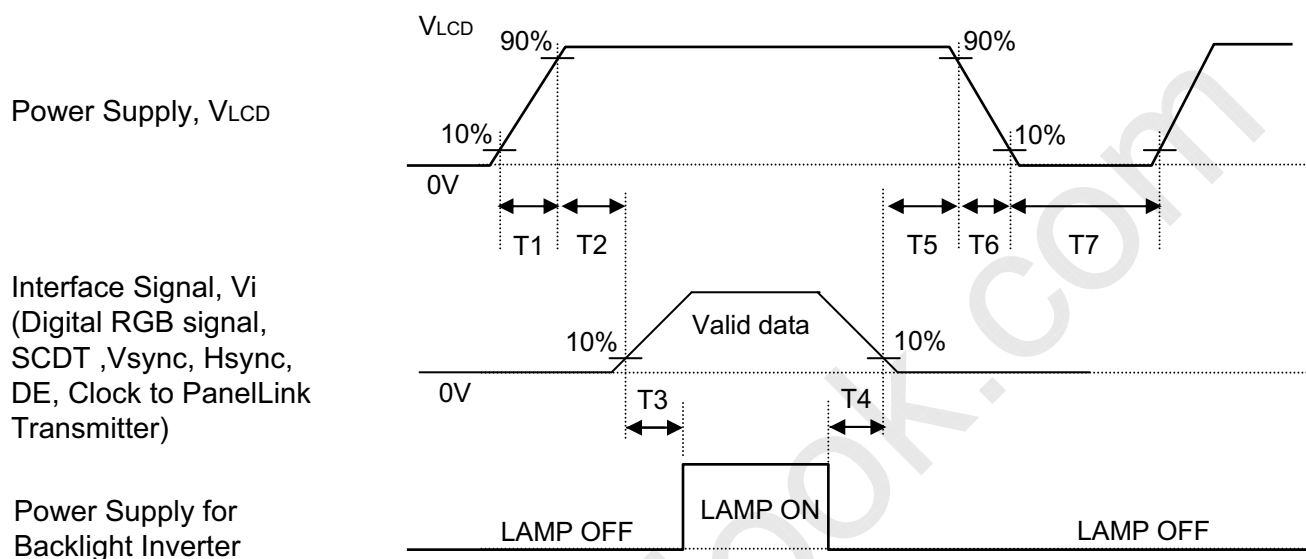
**3-6. Power Sequence**

**Table 8. POWER SEQUENCE**

Parameter	Values			Units
	Min	Typ	Max	
T1	0.5	-	10	ms
T2	0.01	-	50	ms
T3	200	-	-	ms
T4	200	-	-	ms
T5	0.01	-	50	ms
T6	0.01	-	10	ms
T7	400	-	-	ms

- Notes :
1. Please avoid floating state of interface signal at invalid period.
  2. When the interface signal is invalid, be sure to pull down the power supply for LCD  $V_{LCD}$  to 0V.
  3. Lamp power must be turn on after power supply for LCD an interface signal are valid.

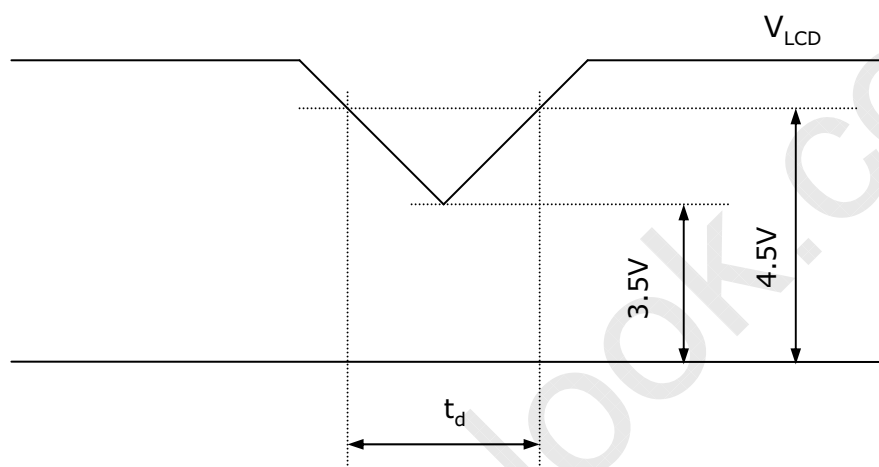

### 3-6. $V_{LCD}$ Power Dip Condition



1) Dip condition

$$3.5V \leq V_{LCD} < 4.5V, t_d \leq 20ms$$

2)  $V_{LCD} < 3.5V$

$V_{LCD}$ -dip conditions should also follow the Power On/Off conditions for supply voltage.

## Product Specification

#### 4. Optical Specification

Optical characteristics are determined after the unit has been 'ON' and stable for approximately 30 minutes in a dark environment at  $25 \pm 2^\circ\text{C}$ . The values specified are at an approximate distance 50cm from the LCD surface at a viewing angle of  $\Phi$  and  $\theta$  equal to  $0^\circ$ .

FIG. 1 presents additional information concerning the measurement equipment and method.

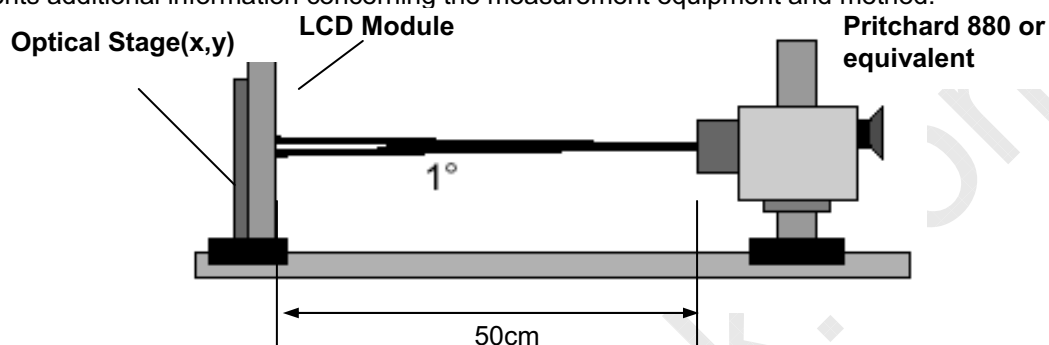

FIG. 1 Optical Characteristic Measurement Equipment and Method

Table 9. OPTICAL CHARACTERISTICS

$T_a = 25^\circ\text{C}$ ,  $V_{\text{LCD}} = 5.0\text{V}$ ,  $f_v = 60\text{Hz}$  Dclk=119MHz,  $I_{\text{BL}} = 7.0\text{mA}$

Parameter	Symbol	Values			Units	Notes	
		Min	Typ	Max			
Contrast Ratio	CR	500	800	-		1	
Surface Luminance, white(5points)	$L_{\text{WH}}$	250	300	-	$\text{cd}/\text{m}^2$	2	
Luminance Variation	$\delta_{\text{WHITE}}$	-	-	30	%	3	
Response Time	Rise Time	$\text{Tr}_R$	-	1.1	2.6	ms	4
	Decay Time	$\text{Tr}_D$	-	3.9	7.4	ms	4
Color Coordinates [CIE1931]	RED	$R_x$	Typ -0.03	0.635	Typ +0.03		
		$R_y$		0.342			
	GREEN	$G_x$		0.292			
		$G_y$		0.611			
	BLUE	$B_x$		0.147			
		$B_y$		0.070			
	WHITE	$W_x$		0.313			
		$W_y$		0.329			
Viewing Angle (CR>10)							
	x axis, right( $\phi=0^\circ$ )	$\theta_r$	70	80		Degree	5
	x axis, left ( $\phi=180^\circ$ )	$\theta_l$	70	80			
	y axis, up ( $\phi=90^\circ$ )	$\theta_u$	60	75			
	y axis, down ( $\phi=270^\circ$ )	$\theta_d$	70	85			
Gray Scale				-			6

## Product Specification

Notes 1. **Contrast Ratio(CR)** is defined mathematically as :

$$\text{Contrast Ratio} = \frac{\text{Surface Luminance with all white pixels}}{\text{Surface Luminance with all black pixels}}$$

2. **Surface luminance** is luminance value at 5 points average across the LCD surface 50cm from the surface with all pixels displaying white. For more information see FIG 2.

$$L_{WH} = \text{Average} [ L_{on1}, L_{on2}, L_{on3}, L_{on4}, L_{on5} ]$$

3. **The variation in surface luminance** ,  $\delta$  WHITE is defined as :

$$\delta_{WHITE} = \frac{\text{Maximum}(L_{on1}, L_{on2}, \dots, L_{on13}) - \text{Minimum}(L_{on1}, L_{on2}, \dots, L_{on13})}{\text{Average}(L_{on1}, L_{on2}, \dots, L_{on5})} \times 100(\%)$$

Measuring point for surface luminance & measuring point for luminance variation

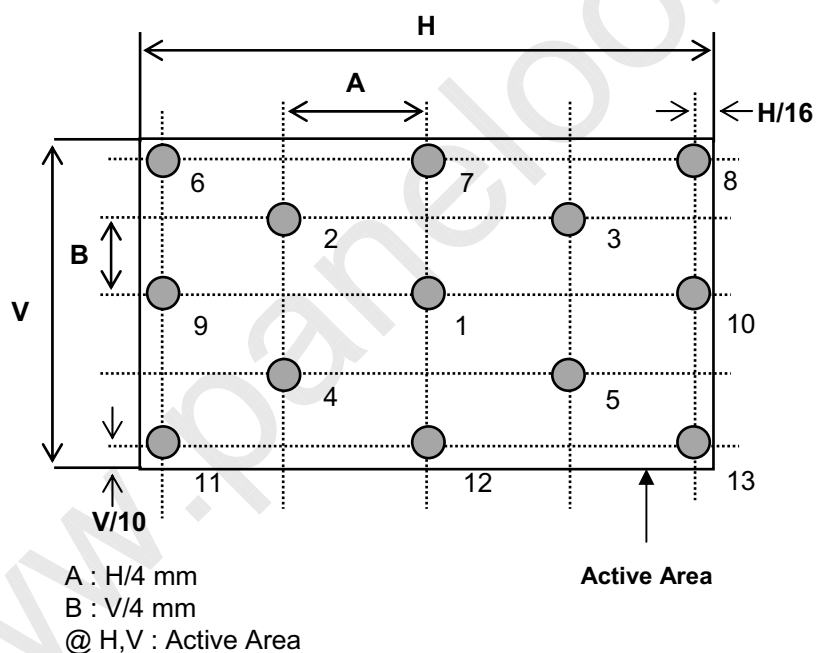
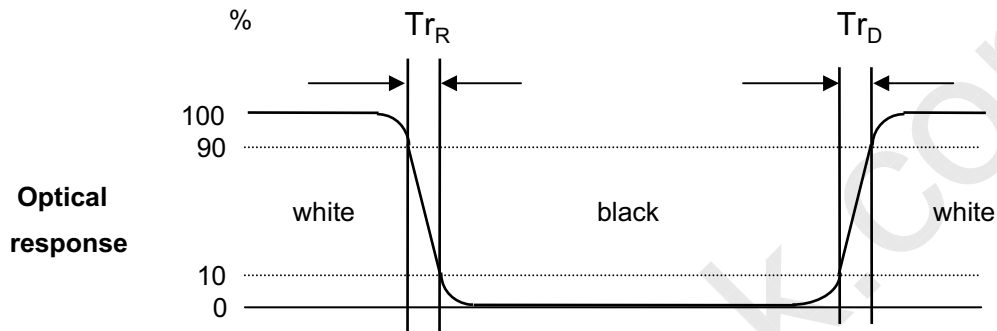

FIG. 2 Measure Point for Luminance

## Product Specification

4. **The response time** is defined as the following figure and shall be measured by switching the input signal for "black" and "white".  
 Response time is the time required for the display to transition from white to black (Rise Time,  $Tr_R$ ) and from black to white (Decay Time,  $Tr_D$ ).

**FIG. 3 Response Time**

5. **Viewing angle** is the angle at which the contrast ratio is greater than 10 or 5. The angles are determined for the horizontal or x axis and the vertical or y axis with respect to the z axis which is normal to the LCD surface. For more information see FIG. 4 .

<Dimension of viewing angle range>

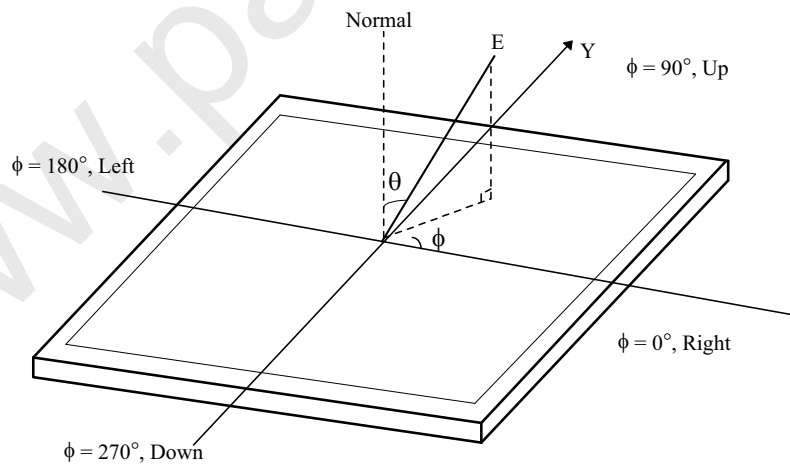
**FIG. 4 Viewing angle**



LM201WE3  
Liquid Crystal Display

Product Specification

6. **Gray scale** specification

Gamma Value is approximately 2.2. For more information see Table 10.

**Table 10. Gray Scale Specification**

Gray Level	Luminance [%] (Typ)
L0	0.11
L15	0.31
L31	1.08
L47	2.53
L63	4.72
L79	7.69
L95	11.49
L111	16.14
L127	21.66
L143	28.09
L159	35.45
L175	43.74
L191	53.00
L207	63.24
L223	74.48
L239	86.73
L255	100

## Product Specification

## 5. Mechanical Characteristics

The contents provide general mechanical characteristics. In addition the figures in the next page are detailed mechanical drawing of the LCD.

Outline Dimension	Horizontal	459.4mm
	Vertical	296.4mm
	Depth	14.5mm
Bezel Area	Horizontal	438.4mm
	Vertical	275.9mm
Active Display Area	Horizontal	433.44mm
	Vertical	270.90mm
Weight	2050 g (Typ.), 2160 g (Max.)	
Surface Treatment	Hard coating(2H) Glare treatment of the front polarizer	

Notes : Please refer to a mechanic drawing in terms of tolerance at the next page.



LM201WE3  
Liquid Crystal Display

Product Specification

<FRONT VIEW>

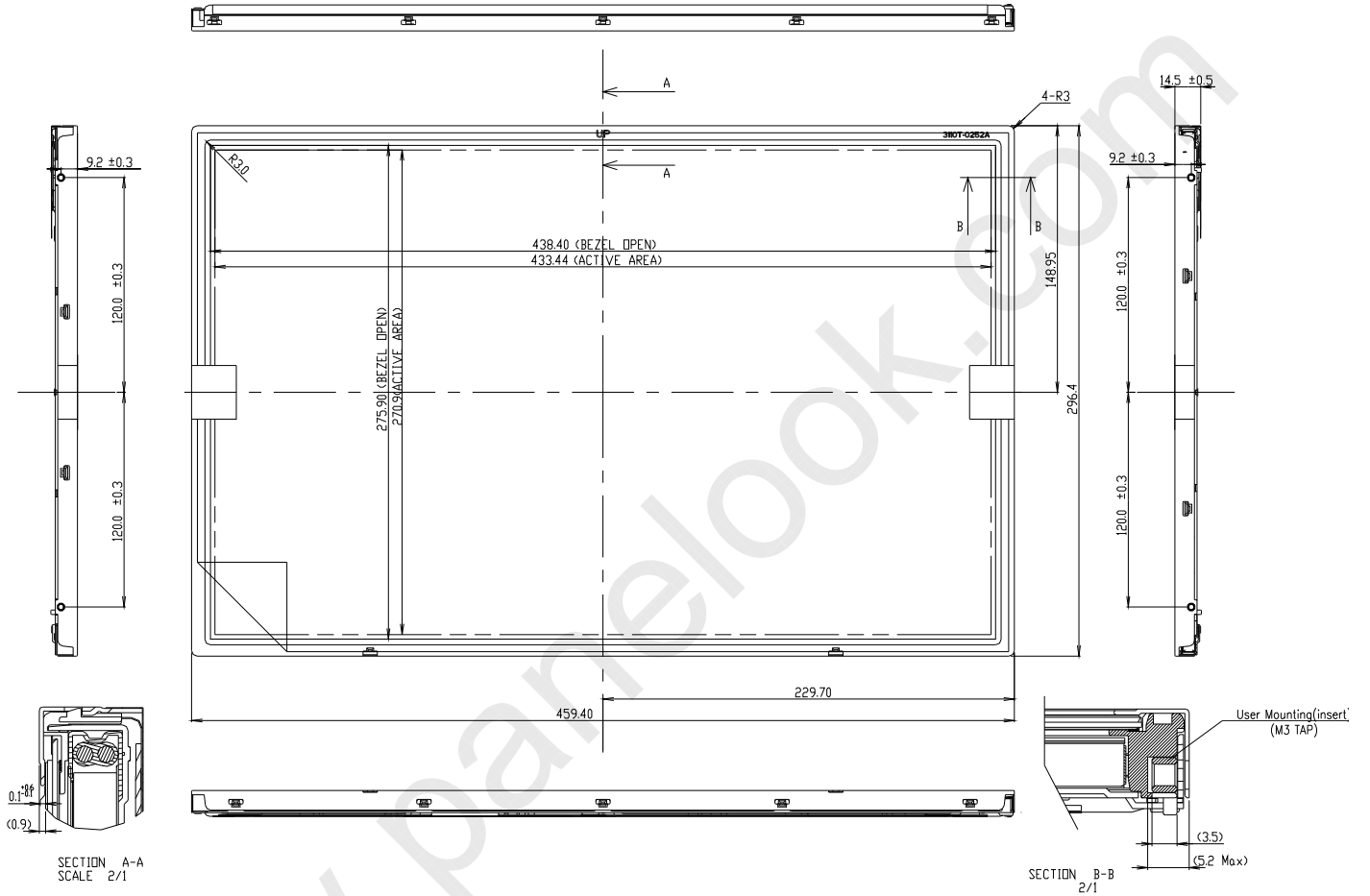



LM201WE3  
Liquid Crystal Display

Product Specification

<REAR VIEW\_LM201WE3-TLF8>

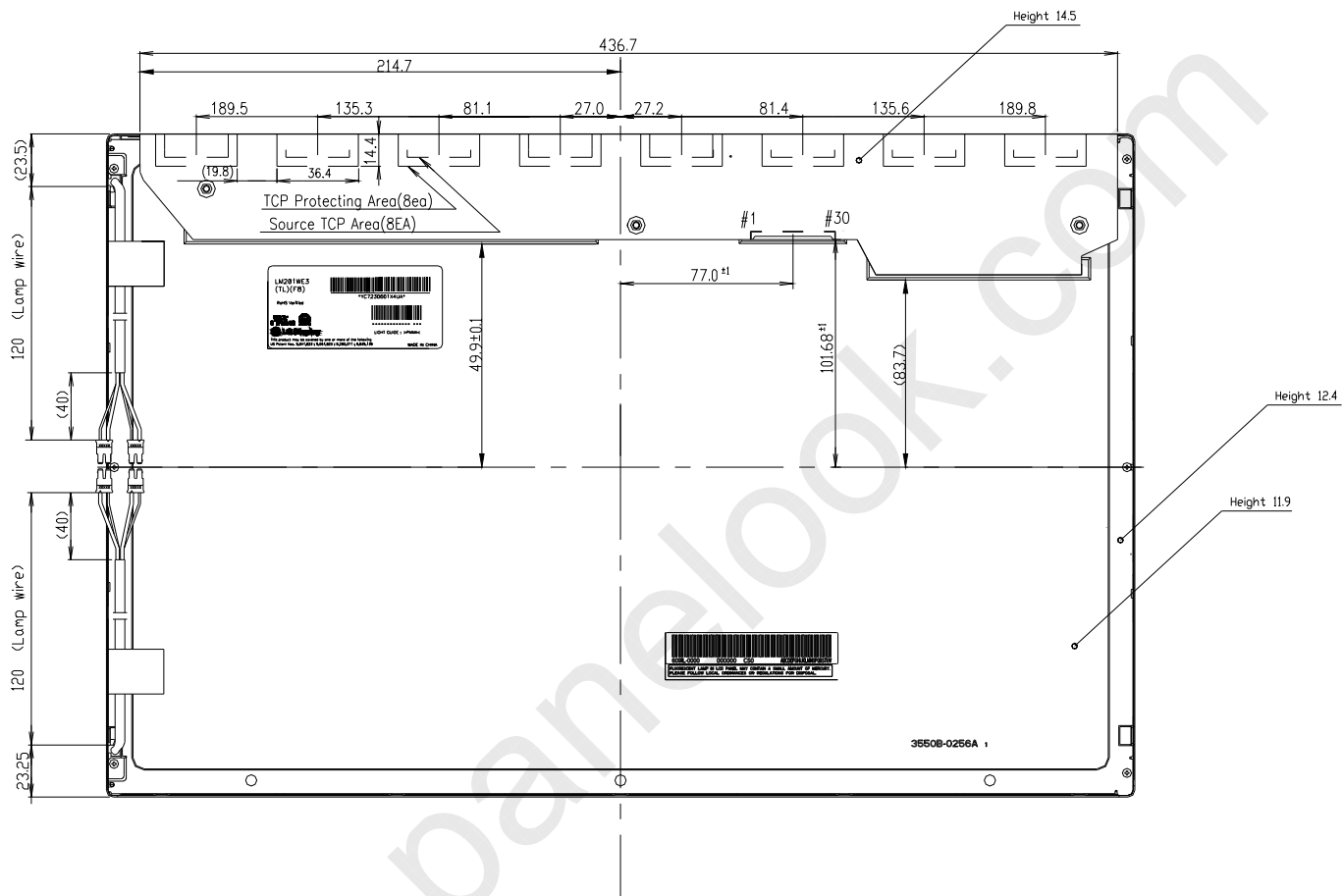

Notes

- 1. Backlight : 4 Cold Cathode Fluorescent Lamps
- 2. Lamp Connector Specification  
- BHSR-02VS-2(JST) or Compatible <2pin>
- 3 Torque of user hole : 3.0~4.0kgf-cm
- 4. Tilt and partial disposition tolerance of display area as following  
(1) Y-Direction : IA-BI ≤ 1.0  
(2) X-Direction : IC-DI ≤ 1.0

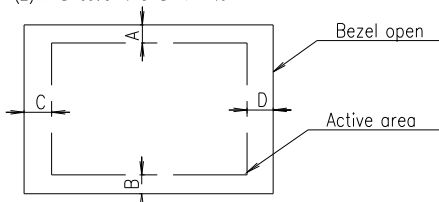

- 5. Lamp(CCFL) lot No. is marked at backlight connector
- 6. Do not wind conductive tape around the backlight wires
- 7. Unspecified tolerances to be ±0.5mm
- 8. The TCP Protecting area is weak & sensitive,  
So, please don't press the TCP Protecting area.



## Product Specification

## 6. Reliability

Environment test condition

No	Test Item	Condition
1	High temperature storage test	Ta= 60°C 240h
2	Low temperature storage test	Ta= -20°C 240h
3	High temperature operation test	Ta= 50°C 50%RH 240h
4	Low temperature operation test	Ta= 0°C 240h
5	Vibration test (non-operating)	Wave form : random Vibration level : 1.0G RMS Bandwidth : 10-500Hz Duration : X,Y,Z, 10 min One time each direction
6	Shock test (non-operating)	Shock level : 100G Waveform : half sine wave, 2ms Direction : ±X, ±Y, ±Z One time each direction
7	Altitude operating storage / shipment	0 - 10,000 feet(3048m) 0 - 40,000 feet(12,192m)

## 7. International Standards

### 7-1. Safety

- a) UL 60950-1:2003, First Edition, Underwriters Laboratories, Inc., Standard for Safety of Information Technology Equipment.
- b) CAN/CSA C22.2, No. 60950-1-03 1<sup>st</sup> Ed. April 1, 2003, Canadian Standards Association, Standard for Safety of Information Technology Equipment.
- c) EN 60950-1:2001, First Edition, European Committee for Electrotechnical Standardization(CENELEC) European Standard for Safety of Information Technology Equipment.

### 7-2. EMC

- a) ANSI C63.4 "Methods of Measurement of Radio-Noise Emissions from Low-Voltage Electrical and Electrical Equipment in the Range of 9kHz to 40GHz." American National Standards Institute(ANSI), 1992
- b) C.I.S.P.R "Limits and Methods of Measurement of Radio Interface Characteristics of Information Technology Equipment." International Special Committee on Radio Interference.
- c) EN 55022 "Limits and Methods of Measurement of Radio Interface Characteristics of Information Technology Equipment." European Committee for Electrotechnical Standardization.(CENELEC), 1998 ( Including A1: 2000 )



LM201WE3  
Liquid Crystal Display

## Product Specification

### 8. Packing

#### 8-1. Designation of Lot Mark

a) Lot Mark

A	B	C	D	E	F	G	H	I	J	K	L	M
---	---	---	---	---	---	---	---	---	---	---	---	---

A,B,C : SIZE(INCH)  
E : MONTH

D : YEAR  
F ~ M : SERIAL NO.

Note

1. YEAR

Year	2001	2002	2003	2004	2005	2006	2007	2008	2009	2010
Mark	1	2	3	4	5	6	7	8	9	0

2. MONTH

Month	Jan	Feb	Mar	Apr	May	Jun	Jul	Aug	Sep	Oct	Nov	Dec
Mark	1	2	3	4	5	6	7	8	9	A	B	C

b) Location of Lot Mark

Serial No. is printed on the label. The label is attached to the backside of the LCD module.  
This is subject to change without prior notice.

#### 8-2. Packing Form

a) Package quantity in one box : 8pcs

b) Box Size : 370mm × 320mm × 521mm

## 9. PRECAUTIONS

Please pay attention to the followings when you use this TFT LCD module.

### 9-1. MOUNTING PRECAUTIONS

- (1) You must mount a module using holes arranged in four corners or four sides.
- (2) You should consider the mounting structure so that uneven force (ex. Twisted stress) is not applied to the module. And the case on which a module is mounted should have sufficient strength so that external force is not transmitted directly to the module.
- (3) Please attach the surface transparent protective plate to the surface in order to protect the polarizer. Transparent protective plate should have sufficient strength in order to resist external force.
- (4) You should adopt radiation structure to satisfy the temperature specification.
- (5) Acetic acid type and chlorine type materials for the cover case are not desirable because the former generates corrosive gas of attacking the polarizer at high temperature and the latter causes circuit break by electro-chemical reaction.
- (6) Do not touch, push or rub the exposed polarizers with glass, tweezers or anything harder than HB pencil lead. And please do not rub with dust clothes with chemical treatment. Do not touch the surface of polarizer for bare hand or greasy cloth. (Some cosmetics are detrimental to the polarizer.)
- (7) When the surface becomes dusty, please wipe gently with absorbent cotton or other soft materials like chamois soaks with petroleum benzene. Normal-hexane is recommended for cleaning the adhesives used to attach front / rear polarizers. Do not use acetone, toluene and alcohol because they cause chemical damage to the polarizer.
- (8) Wipe off saliva or water drops as soon as possible. Their long time contact with polarizer causes deformations and color fading.
- (9) Do not open the case because inside circuits do not have sufficient strength.

### 9-2. OPERATING PRECAUTIONS

- (1) The spike noise causes the mis-operation of circuits. It should be lower than following voltage :  
 $V = \pm 200\text{mV}$  (Over and under shoot voltage)
- (2) Response time depends on the temperature. (In lower temperature, it becomes longer.)
- (3) Brightness depends on the temperature. (In lower temperature, it becomes lower.)  
And in lower temperature, response time (required time that brightness is stable after turned on) becomes longer.
- (4) Be careful for condensation at sudden temperature change. Condensation makes damage to polarizer or electrical contacted parts. And after fading condensation, smear or spot will occur.
- (5) When fixed patterns are displayed for a long time, remnant image is likely to occur.
- (6) Module has high frequency circuits. Sufficient suppression to the electromagnetic interference shall be done by system manufacturers. Grounding and shielding methods may be important to minimize the interference.
- (7) Please do not give any mechanical and/or acoustical impact to LCM. Otherwise, LCM can not be operated its full characteristics perfectly.
- (8) A screw which is fastened up the steels should be a machine screw (if not, it causes metallic foreign material and deal LCM a fatal blow)
- (9) Please do not set LCD on its edge.

**Product Specification****9-3. ELECTROSTATIC DISCHARGE CONTROL**

Since a module is composed of electronic circuits, it is not strong to electrostatic discharge. Make certain that treatment persons are connected to ground through wrist band etc. And don't touch interface pin directly.

**9-4. PRECAUTIONS FOR STRONG LIGHT EXPOSURE**

Strong light exposure causes degradation of polarizer and color filter.

**9-5. STORAGE**

When storing modules as spares for a long time, the following precautions are necessary.

- (1) Store them in a dark place. Do not expose the module to sunlight or fluorescent light. Keep the temperature between 5°C and 35°C at normal humidity.
- (2) The polarizer surface should not come in contact with any other object.  
It is recommended that they be stored in the container in which they were shipped.

**9-6. HANDLING PRECAUTIONS FOR PROTECTION FILM**

- (1) The protection film is attached to the bezel with a small masking tape.  
When the protection film is peeled off, static electricity is generated between the film and polarizer. This should be peeled off slowly and carefully by people who are electrically grounded and with well ion-blown equipment or in such a condition, etc.
- (2) When the module with protection film attached is stored for a long time, sometimes there remains a very small amount of glue still on the bezel after the protection film is peeled off.
- (3) You can remove the glue easily. When the glue remains on the bezel surface or its vestige is recognized, please wipe them off with absorbent cotton waste or other soft material like chamois soaked with normal-hexane.



LM201WE3  
Liquid Crystal Display

Product Specification

10. EDID DATA FOR LM201WE3-TLF8

LM201WE3-TLF7 EDID DATA (1680X1050 @ 60Hz )

modified 03/17/2008

Byte# (decimal)	Byte# (HEX)	Field Name and Comments	Value (HEX)	Value (binary)	
0	0	Header	00	00000000	Header
1	1		FF	11111111	
2	2		FF	11111111	
3	3		FF	11111111	
4	4		FF	11111111	
5	5		FF	11111111	
6	6		FF	11111111	
7	7		00	00000000	
8	8	EISA Manuf. Code LSB (3 character ID = APP	06	00000110	K50LG0ProductID= 0x9c93
9	9	Compressed ASCII	10	00010000	
10	0A	<b>Product Code (9C,93)</b>	<b>93</b>	<b>10010011</b>	
11	0B	hex, LSB first	9C	10011100	Vender/ Product ID
12	0C	32-bit serial#	01	00000001	
13	0D		01	00000001	
14	0E		01	00000001	
15	0F		01	00000001	
16	10	Week of manufacture	00	00000000	
17	11	<b>Year of manufacture 2008</b>	<b>12</b>	<b>00010010</b>	
18	12	EDID Structure Ver # = 1	01	00000001	
19	13	EDID revision # = 3	03	00000011	
20	14	Video input definition	80	10000000	Display Parameter
21	15	Max H image size = 43cm	2B	00101011	
22	16	Max V image size = 27cm	1B	00011011	
23	17	Display Gamma = 2.2	78	01111000	
24	18	Feature support (DPMS) = Active off, RGB color	0A	00001010	
25	19	Red/Green low Bits	AF	10101111	Color Characteristic
26	1A	Blue/White Low Bits	F4	11110100	
27	1B	Red X Rx=0.635	A2	10100010	
28	1C	Red Y Ry =0.342	57	01010111	
29	1D	Green X Gx=0.292	4A	01001010	
30	1E	Green Y Gy =0.611	9C	10011100	
31	1F	Blue X Bx=0.147	25	00100101	
32	20	Blue Y By =0.070	11	00010001	
33	21	White X Wx = 0.313	50	01010000	
34	22	White Y Wy = 0.329	54	01010100	
35	23	Established timing 1	00	00000000	Established Timings
36	24	Established timing 2	00	00000000	
37	25	Manufacturer's timings	10	00010000	kAppleNoncoherentTMDSFlag = 0x10, kAppleCoherentTMDSFlag = 0x08
38	26	Standard timing #1 was not used	01	00000001	
39	27		01	00000001	
40	28	Standard timing #2 was not used	01	00000001	
41	29		01	00000001	



LM201WE3  
Liquid Crystal Display

Product Specification

Byte# (decimal)	Byte# (HEX)	Field Name and Comments	Value (HEX)	Value (binary)	
42	2A	Standard timing #3 was not used	01	00000001	Standard Timing ID
43	2B		01	00000001	
44	2C	Standard timing #4 was not used	01	00000001	
45	2D		01	00000001	
46	2E	Standard timing #5 was not used	01	00000001	
47	2F		01	00000001	
48	30	Standard timing #6 was not used	01	00000001	
49	31		01	00000001	
50	32	Standard timing #7 was not used	01	00000001	
51	33		01	00000001	
52	34	Standard timing #8 was not used	01	00000001	
53	35		01	00000001	
54	36	Detailed timing/monitor	7C	01111100	Detailed Timing Description #1
55	37	Pixel Clock = 119 MHz	2E	00101110	
56	38	Hor active= 1680 pixels	90	10010000	
57	39	Hor blanking= 160 pixels	A0	10100000	
58	3A		60	01100000	
59	3B	Vertical active= 1050 lines	1A	00011010	
60	3C	Vertical blanking= 30 lines	1E	00011110	
61	3D		40	01000000	
62	3E	H sync. Offset= 48 pixels	30	00110000	
63	3F	H sync. Width= 32 pixels	20	00100000	
64	40	V sync. Offset= 3 lines	36	00110110	
65	41	V sync. Width= 6 lines	00	00000000	
66	42	H image size= 433 mm	B1	10110001	
67	43	V image size = 270mm	0E	00001110	
68	44		11	00010001	
69	45	No Horizontal Border	00	00000000	
70	46	No Vertical Border	00	00000000	
71	47	Non-interlaced, Normal display, No stereo, Digital separate sync, H/V pol Negatives	1C	00011100	
72	48	Detailed timing/monitor	00	00000000	Detailed Timing Description #2
73	49	descriptor #2	00	00000000	
74	4A		00	00000000	
75	4B		01	00000001	
76	4C	Version	00	00000000	
77	4D	Apple edid signature	06	00000110	
78	4E	Apple edid signature	10	00010000	
79	4F	Link Type (LVDS, Dual Link, MSB)	30	00110000	
80	50	Pixel and link component format (8bit)	11	00010001	
81	51	Panel features	08	00001000	
82	52		00	00000000	
83	53		00	00000000	
84	54		00	00000000	
85	55		00	00000000	
86	56		00	00000000	
87	57		00	00000000	
88	58		0A	00001010	
89	59		20	00100000	



LM201WE3  
Liquid Crystal Display

Product Specification

Byte# (decimal)	Byte# (HEX)	Field Name and Comments	Value (HEX)	Value (binary)	
90	5A	Detailed timing/monitor	00	00000000	Detailed Timing Description #3  Ascii Data String: LM201WE3-TLF7
91	5B	descriptor #3	00	00000000	
92	5C	LM201WE3-TLF7	00	00000000	
93	5D		FE	11111110	
94	5E		00	00000000	
95	5F	"L"	4C	01001100	
96	60	"M"	4D	01001101	
97	61	"2"	32	00110010	
98	62	"0"	30	00110000	
99	63	"1"	31	00110001	
100	64	"W"	57	01010111	
101	65	"E"	45	01000101	
102	66	"3"	33	00110011	
103	67	"_"	2D	00101101	
104	68	"T"	54	01010100	
105	69	"L"	4C	01001100	
106	6A	"F"	46	01000110	
107	6B	"7"	37	00110111	
108	6C	Detailed timing/monitor	00	00000000	Detailed Timing Description #4  Monitor Name: Color LCD
109	6D	descriptor #4	00	00000000	
110	6E	Color LCD	00	00000000	
111	6F		FC	11111100	
112	70		00	00000000	
113	71	C	43	01000011	
114	72	o	6F	01101111	
115	73	l	6C	01101100	
116	74	o	6F	01101111	
117	75	r	72	01110010	
118	76		20	00100000	
119	77	L	4C	01001100	
120	78	C	43	01000011	
121	79	D	44	01000100	
122	7A		0A	00001010	
123	7B		20	00100000	
124	7C		20	00100000	
125	7D		20	00100000	
126	7E	Extension Flag = 00	00	00000000	Extension Flag
127	7F	Checksum	9A	10011010	Checksum