



深圳市拓普微科技开发有限公司

SHENZHEN TOPWAY TECHNOLOGY CO., LTD.

LM2088DFW-C

LCD Module User Manual

Prepared by: Yang Date: 2012-03-13	Checked by: Date:	Approved by: Date:
---	----------------------------------	-----------------------------------

Rev.	Descriptions	Release Date
0.1	New release	2012-03-13

Table of Content

1. Basic Specifications	3
1.1 Display Specifications	3
1.2 Mechanical Specifications	3
1.3 Block Diagram	3
2. Terminal Functions.....	4
3. Absolute Maximum Ratings	5
4. Electrical Characteristics	5
4.1 DC Characteristics	5
4.2 LED Backlight Circuit Characteristics	5
4.3 AC Characteristics.....	6
4.4 Reset Timing	7
4.5 Touch screen controller timing diagram.....	8
5. Function Specifications.....	9
5.1 Adjusting the Display Contrast.....	9
5.2 Resetting the LCD module	9
5.3 Interfacing Setting	9
5.4 Display Pixel Map.....	9
5.5 LCD Controller Command Summary	10
5.6 Touch screen controller command	11
5.7 Initialization Setting Example.....	12
6. Design and Handling Precaution	13

1. Basic Specifications

1.1 Display Specifications

- 1) LCD Display Mode : STN, Negative, Transmissive
- 2) Display Color : Display Data = "1" : Light Gray (*1)
: Display Data = "0" : Dark Blue (*2)
- 3) Viewing Angle : 6H
- 4) Driving Method : 1/240 duty, 1/14 bias
- 5) Backlight : White LED backlight

Note:

*1. Color tone may slightly change by Temperature and Driving Condition.

*2. The Color is defined as the inactive / background color

1.2 Mechanical Specifications

- 1) Outline Dimension : 160.0 x 109.0 x 13.7 MAX.(including touch panel)
see attached Outline Drawing for details

1.3 Block Diagram

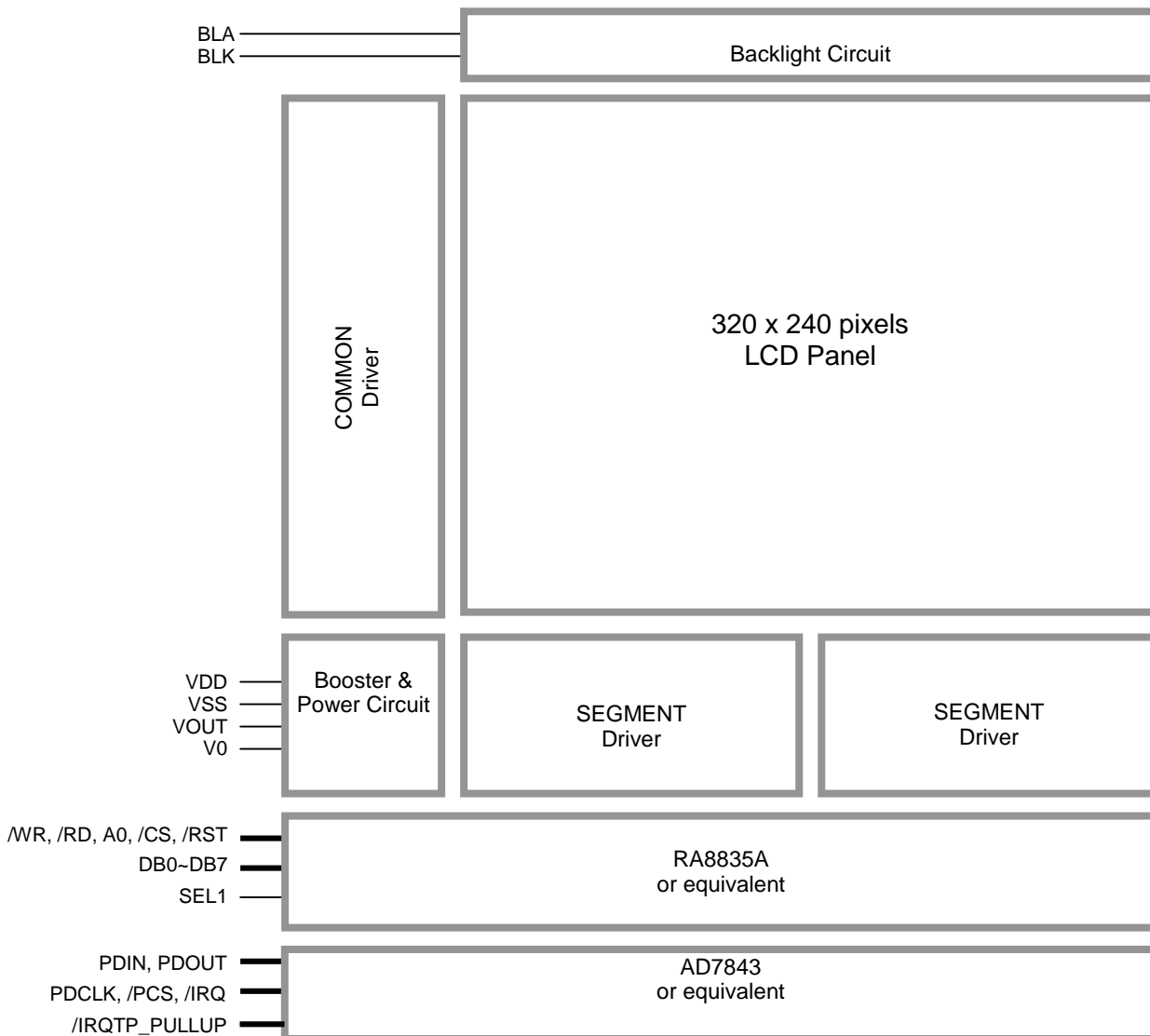

2. Terminal Functions

Pin No. K5	Pin Name	I/O	Descriptions					
1	VSS	Power	0V Power Supply, GND					
2	VDD	Power	Positive Power Supply					
3	V0	Input	LCD Contrast Reference Input					
4	A0	Input	Data Type Select A0=H: command write, display data or cursor add read A0=L: status flag read, display data or parameter write					
5	/WR	Input	Write enable input, active LOW					
6	/RD	Input	Read enable input, active LOW					
7	DB0	I/O	8-bit bi-directional data bus					
:	:							
14	DB7							
15	/CS	Input	Chip Select Signal /CS=LOW: Data IO is enabled					
16	/RST	Input	Reset Signal: /RES = L, Reset the LCD Module /RES = H, Normal Running					
17	VOUT	Power	Power Booster Output for V0					
18	SEL1	Input	SEL1	Interface	A0	RD	WR	CS
			0	8080 mode	A0	RD	WR	CS
			1	6800 mode	A0	E	R/W	CS
19	DCLK	Input	Serial/conversation clock for touch panel digitizer					
20	/CSTP	Input	Touch panel digitizer selection signal					
21	DIN	Input	Data for touch panel digitizer					
22	DOUT	Output	The conversation data output					
23	IRQTP	Output	Pen interrupt					
24	IRQTP_PULLUP	Input	IRQTP Interminal pull up resister terminal					
25	NC	-	No connection					
26	NC	-	No connection					

3. Absolute Maximum Ratings

Items	Symbol	Min.	Max.	Unit	Condition
Supply Voltage	V_{DD}	0	+5.5	V	$V_{SS} = 0V$
Input Voltage	V_{IN}	$V_{SS}-0.3$	$V_{DD}+0.3$	V	$V_{SS} = 0V$
Operating Temperature	T_{OP}	-20	+70	°C	No Condensation
Storage Temperature	T_{ST}	-30	+80	°C	No Condensation

Cautions:

Any Stresses exceeding the Absolute Maximum Ratings may cause substantial damage to the device. Functional operation of this device at other conditions beyond those listed in the specification is not implied and prolonged exposure to extreme conditions may affect device reliability.

4. Electrical Characteristics

4.1 DC Characteristics

$V_{SS}=0V, V_{DD}=5.0V, T_{OP}=25^{\circ}C$

Items	Symbol	MIN.	TYP.	MAX.	Unit	Applicable Pin
Operating Voltage	V_{DD}	4.7	5.0	5.3	V	VDD
Input High Voltage	V_{IN}	0.8xVDD	-	VDD	V	DB0~DB7, /WR, /RD, /CS, A0, /RST
		0.7xVDD	-	$V_{DD}+0.3$	V	DCLK,DOUT,DIN,/CSTP
Input Low Voltage	V_{IN}	VSS	-	0.1xVDD	V	DB0~DB7, /WR, /RD, /CS, A0, /RST
		-0.3	-	0.8	V	DCLK,DOUT,DIN,/CSTP
LCD Contrast Reference Voltage	V_0	-	22.5	-	V	V0
Operating Current	I_{DD}	-	30.0	-	mA	VDD

4.2 LED Backlight Circuit Characteristics

$BLK=0V, I_{f_{BLA}}=153mA, T_{OP}=25^{\circ}C$

Items	Symbol	MIN.	TYP.	MAX.	Unit	Applicable Pin
Forward Voltage	$V_{f_{BLA}}$	-	5.0	-	V	BLA
Forward Current	$I_{f_{BLA}}$	-	153	180	mA	BLA

Cautions:

Exceeding the recommended driving current could cause substantial damage to the backlight and shorten its lifetime.

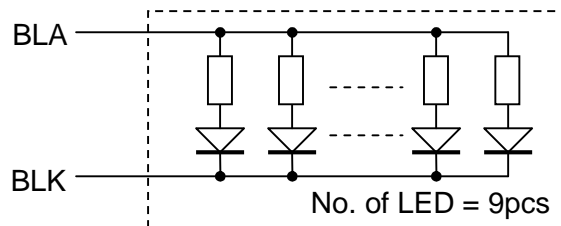

4.3 AC Characteristics

4.3.1 8080 Mode

$V_{SS}=0V, V_{DD}=5.0V, T_{OP}=25^{\circ}C$

Item	Symbol	MIN.	TYP.	MAX.	Unit
Address Hold Time	tah8	13	-	-	ns
Address Setup Time	taw8	5	-	-	ns
System Cycle Time	tcyc8	(*2)	-	-	ns
Strobe Pulse Width	tcc8	150	-	-	ns
Data Setup Time	tds8	150	-	-	ns
Data Hold Time	tdh8	7	-	-	ns
Data Access Time	tacc8	-	-	65	ns
Output disable Time	toh8	13	-	65	ns

Note:

- *1. Input signal rise/fall time should be less than 20ns
- *2. For memory control and system control commands: $tcyc8=2tc+tcc8+tcea+75>tacv+245$
For all other command: $tcyc8=4tc+tcc8+30$
- *3. Please see the RA8835 data sheet for details

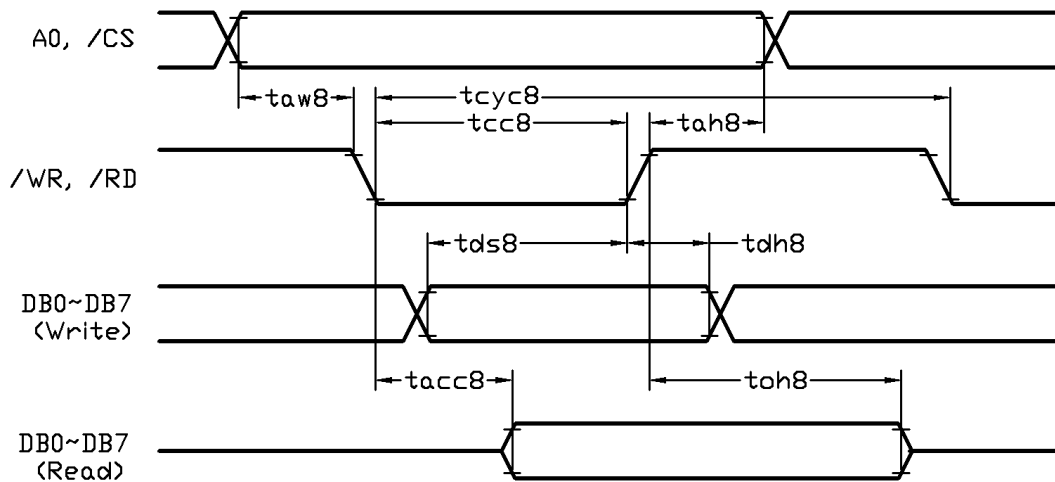

Bus Timing Diagram

4.3.2 6800 Mode

$V_{SS}=0V, V_{DD}=5.0V, T_{OP}=25^{\circ}C$

Item	Symbol	MIN.	TYP.	MAX.	Unit
System Cycle Time	tcyc6	(*2)	-	-	ns
Address Setup Time	taw6	5	-	-	ns
Address Hold Time	tah6	5	-	-	ns
Data Setup Time	tds6	125	-	-	ns
Data Hold Time	tdh6	5	-	-	ns
Output disable Time	toh6	13	-	65	ns
Data Access Time	tacc6	-	-	110	ns
Enable Pulse Width	tew6	150	-	-	ns

Note:

- *1. Input signal rise/fall time should be less than 20ns
- *2. For memory control and system control commands: $tcyc8=2tc+tew6+tcea+75>tacv+245$
- *3. For all other command: $tcyc8=4tc+tcc+30$
- *4. Please see the RA8835 data sheet for details

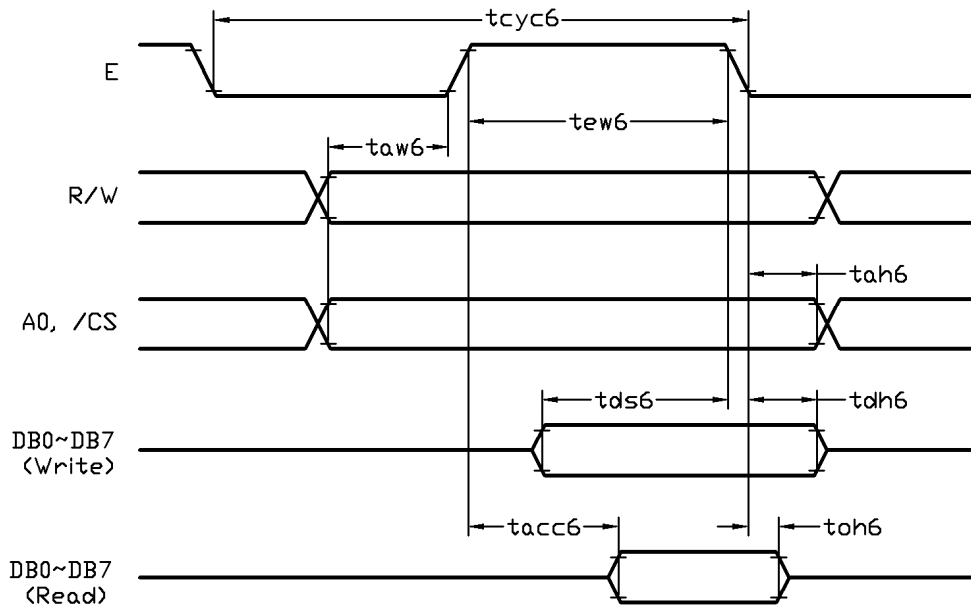

Bus Timing Diagram

4.4 Reset Timing

$V_{SS}=0V, V_{DD}=5.0V, T_{OP}=25^{\circ}C$

Item	Symbol	MIN.	TYP.	MAX.	Unit
Reset Plus	tres	1.0	-	-	ms

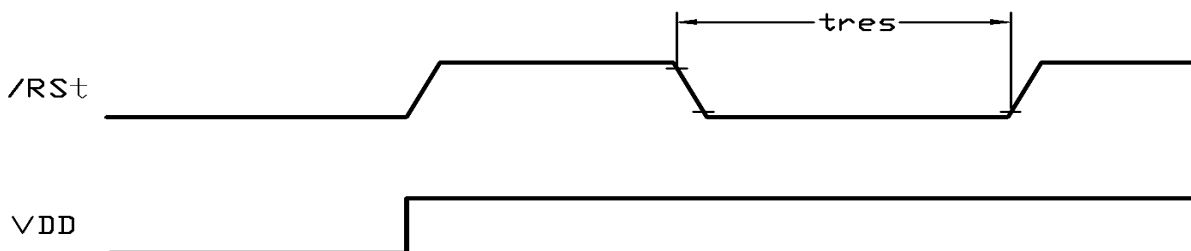

Reset Timing Diagram

4.5 Touch screen controller timing diagram

Item	Symbol	MIN.	TYP.	MAX.	Unit
Acquisition time(*1)	t _{ACQ}	1.5	-	-	us
/CS Falling to First DCLK Rising	t ₁	10	-	-	ns
/CS Falling to BUSY Enabled(*2)	t ₂	-	-	60	ns
/CS Falling to DOUT Enabled	t ₃	-	-	60	ns
DCLK high pulse width	t ₄	200	-	-	ns
DCLK low pulse width	t ₅	200	-	-	ns
DCLK Falling to BUSY Rising(*2)	t ₆	-	-	60	ns
Data setup prior to DCLK Rising	t ₇	10	-	-	ns
Data Hold to DCLK hold time	t ₈	10	-	-	ns
Data access time after DCLK falling	t ₉	-	-	200	ns
/CS Rising to DOUT Disabled	t ₁₀	0	-	-	ns
/CS Rising to BUSY high impedance(*2)	t ₁₁	-	-	200	ns
/CS Rising to DOUT high impedance	t ₁₂	-	-	200	ns

NOTE:

*1 See Serial Data Sequence Diagram

*2 The BUSY signal is not connected to Terminal (K1), after one control byte send via DIN, some delay is needed to read the conversation result through DOUT

*3 Please see the AD7843E datasheet for details

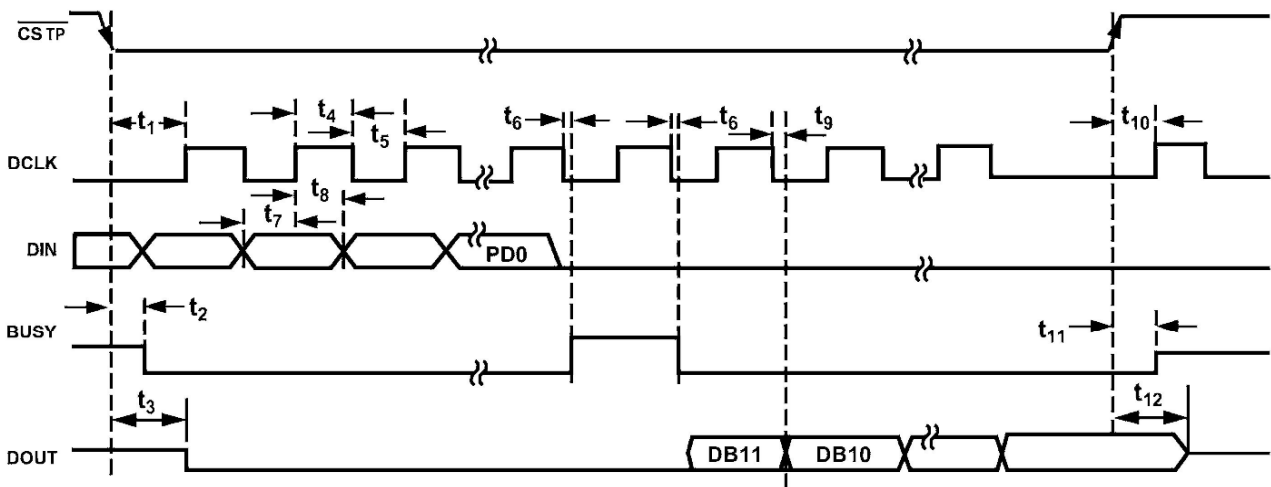

Timing diagram

5. Function Specifications

5.1 Adjusting the Display Contrast

A Variable-Resistor must be connected to the LCD module for providing a reference to V0. Adjusting the VR will result the change of LCD display contrast. The recommended value of VR is 25k to 50k

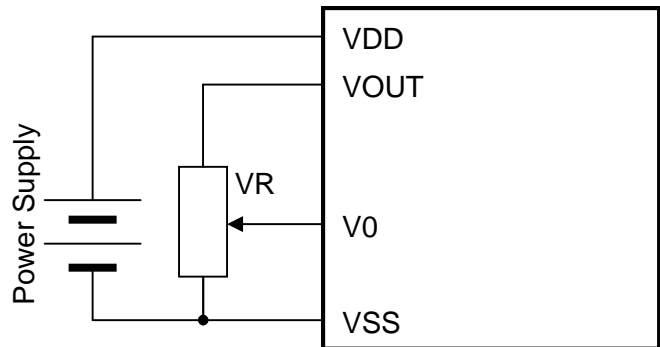

5.2 Resetting the LCD module

The LCD module should be initialized by hardware reset, using /RES terminal.

5.3 Interfacing Setting

SEL1 could also be configured by on board jumpers

Jumper		SEL1	Function Description
JP4	JP3		
open	open	L	8080 mode selected
open	close	H	6800 mode selected

5.4 Display Pixel Map

1,1 (D7)	2,1 (D6)	3,1 (D5)	4,1 (D4)	5,1 (D3)	---	---	316,1 (D4)	317,1 (D3)	318,1 (D2)	319,1 (D1)	320,1 (D0)
1,2 (D7)	2,2 (D6)	3,2 (D5)	4,2 (D4)	5,2 (D3)	---	---	316,2 (D4)	317,2 (D3)	318,2 (D2)	319,2 (D1)	320,2 (D0)
1,3 (D7)	2,3 (D6)	3,3 (D5)	4,3 (D4)	5,3 (D3)	---	---	316,3 (D4)	317,3 (D3)	318,3 (D2)	319,3 (D1)	320,3 (D0)
:	:	:	:	:	:	:	:	:	:	:	:
1,238 (D7)	2,238 (D6)	3,238 (D5)	4,238 (D4)	5,238 (D3)	---	---	316,238 (D4)	317,238 (D3)	318,238 (D2)	319,238 (D1)	320,238 (D0)
1,239 (D7)	2,239 (D6)	3,239 (D5)	4,239 (D4)	5,239 (D3)	---	---	316,239 (D4)	317,239 (D3)	318,239 (D2)	319,239 (D1)	320,239 (D0)
1,240 (D7)	2,240 (D6)	3,240 (D5)	4,240 (D4)	5,240 (D3)	---	---	316,240 (D4)	317,240 (D3)	318,240 (D2)	319,240 (D1)	320,240 (D0)

Pixel mapping (Top View)

Note:

- *1. Based on the top view of the LCD module, the 1, 1 (x, y) pixel is the upper-left pixel; the 320, 240 (x, y) pixel is the lower-right pixel.
- *2. For the details of memory mapping please refer to RA8835 datasheet.

5.5 LCD Controller Command Summary

Command	Parameter	A0	/RD	/WR	D7	D6	D5	D4	D3	D2	D1	D0	HEX	Descriptions	
SYSTEM SET	-	1	1	0	0	1	0	0	0	0	0	0	40	Init device and display (with 8 parameters)	
	P1	0	1	0	0	0	IV	1	W/S	M2	M1	M0	**	M0=0: internal CG ROM M0=1: external CG ROM M1=0: no D6 correction M1=1: D6 correction M2=0: 8-pixel char height M2=1: 16-pixel char height W/S=0: single panel drive W/S=1: dual panel drive IV=0: Screen top-line correction IV=1: No screen top-line correction	
	P2	0	1	0	WF	0	0	0	0		FX		**	FX: define the horizontal char size WF=0: 16-line AC drive WF=1: two frame AC drive	
	P3	0	1	0	0	0	0	0			FY		**	FY: Vertical Char Size	
	P4	0	1	0					C/R				**	C/R: display line address range	
	P5	0	1	0					TC/R				**	TC/R: Line length selection	
	P6	0	1	0					L/F				**	L/F: Frame Height selection	
	P7	0	1	0					APL				**	APL: Horizontal address range (low byte)	
	P8	0	1	0					APH				**	APH: Horizontal address range (high byte)	
SLEEP IN	-	1	1	0	0	1	0	1	0	0	1	1	53	Enter standby mode	
DISP ON/OFF	-	1	1	0	0	1	0	1	1	0	0	D	58 / 59	Enable and disable display and display flashing (with 1 parameter)	
	P1	0	1	0	FP5	FP4	FP3	FP2	FP1	FP0	FC1	FC0	**	Each pair of bit in FP sets the attributes of one screen block	
SCROLL	-	1	1	0	0	1	0	0	0	1	0	0	44	Set display start address and display regions (with 8 or 10 parameters)	
	P1	0	1	0	A7	A6	A5	A4	A3	A2	A1	A0	**	SAD 1L	
	P2	0	1	0	A15	A14	A13	A12	A11	A10	A9	A8	**	SAD 1H	
	P3	0	1	0	L7	L6	L5	L4	L3	L2	L1	L0	**	SL1	
	P4	0	1	0	A7	A6	A5	A4	A3	A2	A1	A0	**	SAD 2L	
	P5	0	1	0	A15	A14	A13	A12	A11	A10	A9	A8	**	SAD 2H	
	P6	0	1	0	L7	L6	L5	L4	L3	L2	L1	L0	**	SL2	
	P7	0	1	0	A7	A6	A5	A4	A3	A2	A1	A0	**	SAD3L	
	P8	0	1	0	A15	A14	A13	A12	A11	A10	A9	A8	**	SAD3H	
	P9	0	1	0	A7	A6	A5	A4	A3	A2	A1	A0	**	SAD4L (for both two-screen drive and two layer config are select)	
	P10	0	1	0	A15	A14	A13	A12	A11	A10	A9	A8	**	SAD4H (for both two-screen drive and two layer config are select)	
CSRFORM	-	1	1	0	0	1	0	1	1	1	0	1	5D	Set cursor type (with 2 parameters)	
	P1	0	1	0	0	0	0	0	X3	X2	X1	X0	**	CRX	
	P2	0	1	0	CM	0	0	0	Y3	Y2	Y1	Y0	**	CRY CM=0: underscore cursor; CM=1: block cursor	
CGRAM ADR	-	1	1	0	0	1	0	1	1	1	0	0	5C	Set Start address of char generator RAM (with 2 parameters)	
	P1	0	1	0	A7	A6	A5	A4	A3	A2	A1	A0	**	SAGL	
	P2	0	1	0	A15	A14	A13	A12	A11	A10	A9	A8	**	SAGH	
CSRDIR	-	1	1	0	0	1	0	0	1	1	CD1	CD0	4C~4F	Set Direction of Cursor movement	
HDOT SCR	-	1	1	0	0	1	0	0	1	1	0	1	0	5A	Set horizontal scroll position (with 1 parameters)
	P1	0	1	0	0	0	0	0	0	D2	D1	D0	**		
OVLAY	-	1	1	0	0	1	0	1	1	0	1	1	5B	Set display overlay format (with 1 parameters)	
	P1	0	1	0	0	0	0	OV	DM2	DM1	MX1	MX0	**		
CSRW	-	1	1	0	0	1	0	0	0	1	1	0	46	Set cursor address (with 2 parameters)	
	P1	0	1	0	A7	A6	A5	A4	A3	A2	A1	A0	**	CSRL	
	P2	0	1	0	A15	A14	A13	A12	A11	A10	A9	A8	**	CSRH	
CSRRL	-	1	1	0	0	1	0	0	0	1	1	1	47	Read Cursor Address (with 2 parameters)	
	P1	1	0	1	A7	A6	A5	A4	A3	A2	A1	A0	**	CSRL	
	P2	1	0	1	A15	A14	A13	A12	A11	A10	A9	A8	**	CSRH	
MWRITE	-	1	1	0	0	1	0	0	0	0	1	0	42	Write to display memory (with n parameters)	
	P1	0	1	0	Memory Data							**	Display memory data		
	:	:	:	:	:							**			
	Pn	0	1	0	Memory Data							**			
MREAD	-	1	1	0	0	1	0	0	0	0	1	1	43	Read from display memory (with n parameters)	
	P1	1	0	1	Memory Data							**	Display memory data		
	:	:	:	:	:							**			
	Pn	1	0	1	Memory Data							**			

Note:
For details please refer to RA8835

5.6 Touch screen controller command

Command	/IRQ	/CSTP	D7	D6	D5	D4	D3	D2	D1	D0	HEX	Descriptions
CONTROL REGISTER (*1)	0	0	S	A2	A1	A0	MODE	SER/DER	PD1	PD0	**	S: Start bit ,must be 1 A2-A0: Channel select bit Mode:12 bit/8bit Conversation Selection Bit SER/DFR: Signal -Enable/Differential Reference selection bit PD1-PD0:Power Management Bits

Note:

*1 Control register set to 90H when panel touched(/IRQ=0,see /IRQ Timing Diagram), Set to 93H or D3H to read the conversation data

*2 For more details, please refer to datasheet of AD7843

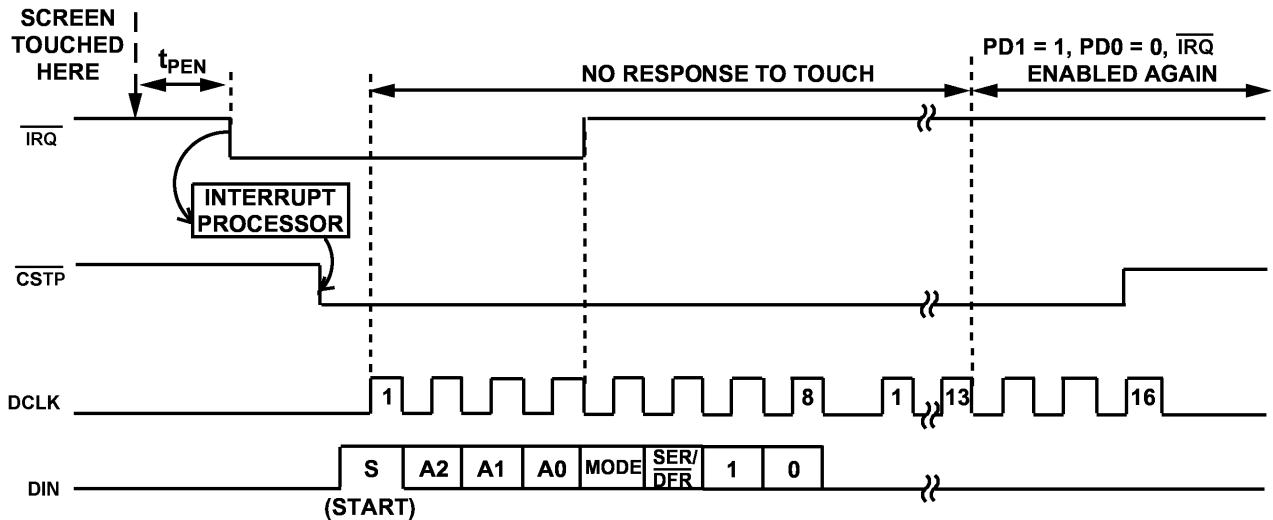

/IRQ Timing Diagram

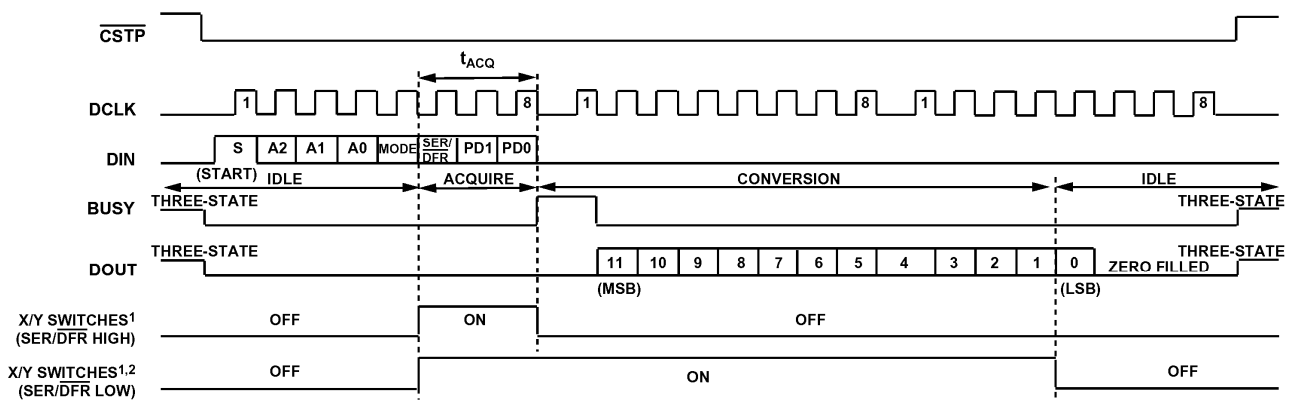

Serial Data Sequence

5.7 Initialization Setting Example

The following setting should be issue to LCD module after hardware reset.
(It is an example only; it could be adjusted if necessary.)

Command	Parameter	A0	/RD	/WR	Value (binary)	HEX	Descriptions
SYSTEM SET	-	1	1	0	0100 0000	40	Init device and display, (with 8 parameters)
	P1	0	1	0	0011 0000	30	M0=0: internal CG ROM M0=1: external CG ROM M1=0: no D6 correction M1=1: D6 correction M2=0: 8-pixel char height M2=1: 16-pixel char height W/S=0: single panel drive W/S=1: dual panel drive IV=0: Screen top-line correction IV=1: No screen top-line correction
	P2	0	1	0	1000 0111	87	FX: define the horizontal char size WF=0: 16-line AC drive WF=1: two frame AC drive
	P3	0	1	0	0000 0000	00	FY: Vertical Char Size
	P4	0	1	0	0010 1000	28	C/R: display line address range
	P5	0	1	0	0100 0101	45	TC/R: Line length selection
	P6	0	1	0	1110 1111	EF	L/F: Frame Height selection
	P7	0	1	0	0010 1000	28	APL: Horizontal address range (low byte)
	P8	0	1	0	0000 0000	00	APH: Horizontal address range (high byte)
DISP ON/OFF	-	1	1	0	0101 1001	59	Enable
	P1	0	1	0	0000 0100	04	
SCROLL	-	1	1	0	0100 0100	44	Set cursor type (with 10 parameters)
	P1	0	1	0	0000 0000	00	SAD 1L
	P2	0	1	0	0000 0000	00	SAD 1H
	P3	0	1	0	1110 1111	EF	SL1
	P4	0	1	0	0000 0000	00	SAD 2L
	P5	0	1	0	0000 0000	00	SAD 2H
	P6	0	1	0	1110 1111	EF	SL2
	P7	0	1	0	0000 0000	00	SAD3L
	P8	0	1	0	0000 0000	00	SAD3H
CSRDIR	-	1	1	0	0100 1100	4C	Set Direction of Cursor movement
HDOT SCR	-	1	1	0	0101 1010	5A	Set horizontal scroll position (with 1 parameters)
	P1	0	1	0	0000 0000	00	
OVLAY	-	1	1	0	0101 1011	5B	Set display overlay format (with 1 parameters)
	P1	0	1	0	0000 1101	0D	
CSRW	-	1	1	0	0100 0110	46	Set cursor address (with 2 parameters)
	P1	0	1	0	0000 0000	00	CSRL
	P2	0	1	0	0000 0000	00	CSRH
MWRITE	-	1	1	0	0100 0010	42	Write to display memory (with n parameters)
	P1	0	1	0	Memory Data	**	Display memory data
	:	:	:	:	:	**	
	Pn	0	1	0	Memory Data	**	

Note:

For details please refer to RA8835 datasheet.

6. Design and Handling Precaution

1. The LCD panel is made by glass. Any mechanical shock (eg. dropping from high place) will damage the LCD module.
2. Do not add excessive force on the surface of the display, which may cause the Display color change abnormally.
3. The polarizer on the LCD is easily get scratched. If possible, do not remove the LCD protective film until the last step of installation.
4. Never attempt to disassemble or rework the LCD module.
5. Only Clean the LCD with Isopropyl Alcohol or Ethyl Alcohol. Other solvents (eg. water) may damage the LCD.
6. When mounting the LCD module, make sure that it is free from twisting, warping and distortion.
7. Ensure to provide enough space (with cushion) between case and LCD panel to prevent external force adding on it, or it may cause damage to the LCD or degrade the display result.
8. Only hold the LCD module by its side. Never hold LCD module by add force on the heat seal or TAB.
9. Never add force to component of the LCD module. It may cause invisible damage or degrade of the reliability.
10. LCD module could be easily damaged by static electricity. Be careful to maintain an optimum anti-static work environment to protect the LCD module.
11. When peeling off the protective film from LCD, static charge may cause abnormal display pattern. It is normal and will resume to normal in a short while.
12. Take care and prevent get hurt by the LCD panel sharp edge.
13. Never operate the LCD module exceed the absolute maximum ratings.
14. Keep the signal line as short as possible to prevent noisy signal applying to LCD module.
15. Never apply signal to the LCD module without power supply.
16. IC chip (eg. TAB or COG) is sensitive to the light. Strong lighting environment could possibly cause malfunction. Light sealing structure casing is recommend.
17. LCD module reliability may be reduced by temperature shock.
18. When storing the LCD module, avoid exposure to the direct sunlight, high humidity, high temperature or low temperature. They may damage or degrade the LCD module