

TO : \_\_\_\_\_

规格书编号 File No.	PN-RD-0001A
作成日 Issue Date:	2011 年 (Y) 12 月 (M) 13 日 (D)
改订日 Revision Date:	2012 年 (Y) 10 月 (M) 17 日 (D)

《新规  
New



# 产品规格书

## Product Specification

产品名  
Product TFT-LCD OPEN CELL

机种名  
Model LM215DA-T01

【接收印栏】

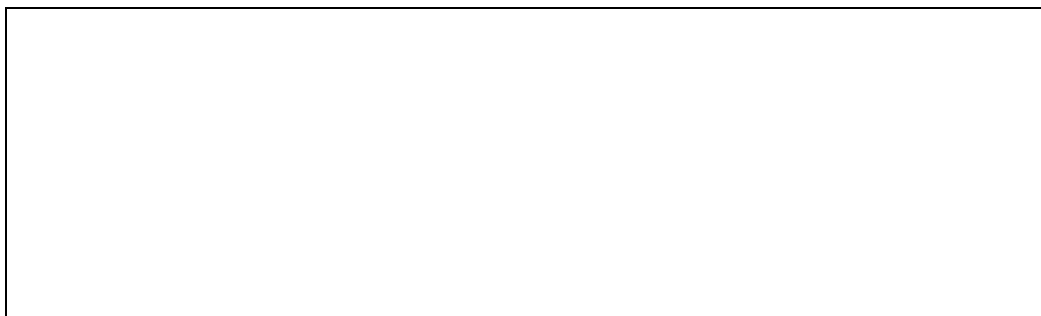

※ 本基准书由封面、附件等全 19 页构成。

如果对该规格书有异议，请在下订单前提出。

※ This Product Specification have 19 pages including the coversheet and Appendices. Please negotiate the objection point before purchase order.

中电熊猫集团  
南京中电熊猫液晶显示科技有限公司  
研发中心 设计整合部

CEC PANDA GROUP  
NANJING CEC PANDA LCD TECHNOLOGY CO., LTD.  
R&D CENTER, DESIGN INTEGRATION SECTION.

副总	部长	科长	主管	担当
朱 3/12 10/18	刘 12/10/12	李 2012.10.18		杨 17/10

---

---

**- CONTENTS -**

<b>REVISION HISTORY</b>	-----	<b>3</b>
<b>1. GENERAL DESCRIPTION</b>	-----	<b>4</b>
1.1 OVERVIEW		
1.2 CHARACTERISTICS		
<b>2. ABSOLUTE MAXIMUM RATINGS</b>	-----	<b>4</b>
2.1 ABSOLUTE RATINGS OF ENVIRONMENT		
<b>3. ELECTRICAL CHARACTERISTICS</b>	-----	<b>5</b>
3.1 ABSOLUTE MAXIMUM RATING		
3.2 CONTROL CIRCUIT DRIVING		
<b>4. INPUT TERMINAL PIN ASSIGNMENT</b>	-----	<b>7</b>
4.1 TFT LCD OPEN CELL		
4.2 BLOCK DIAGRAM (OPEN CELL)		
4.3 LVDS INTERFACE		
4.4 COLOR DATA INPUT ASSIGNMENT		
<b>5. INTERFACE TIMING</b>	-----	<b>11</b>
5.1 INPUT SIGNAL TIMING SPECIFICATIONS		
<b>6. OPTICAL CHARACTERISTICS</b>	-----	<b>12</b>
6.1 OPTICAL SPECIFICATION		
6.2 FLICKER ADJUSTMENT		
<b>7. DEFINITIONS OF LABELS</b>	-----	<b>15</b>
7.1 MULTI-CELL LABEL		
7.2 OPEN-CELL LABEL		
7.3 CELLBOX LABEL		
<b>8. Packing</b>	-----	<b>16</b>
8.1 PACKING SPECIFICATIONS		
8.2 PACKING METHOD		
<b>9. PRECAUTIONS</b>	-----	<b>16</b>
<b>10. RELIABILITY TEST ITEMS</b>	-----	<b>18</b>
<b>11. MECHANICAL DRAWING</b>	-----	<b>18</b>



## 1. GENERAL DESCRIPTION

### 1.1 OVERVIEW

This module is color active matrix LCD Open-cell incorporating amorphous silicon TFT (Thin Film Transistor). It is composed of a color TFT-LCD panel, driver ICs, PWB. Graphics and texts can be displayed on a 1920×RGB×1080 dots panel with about 16.7M colors (R/G/B 6bits+Hi FRC data in each color) by using LVDS(Low Voltage Differential Signaling) to interface, +5V of DC supply voltage.

### 1.2 CHARACTERISTICS

CHARACTERISTICS ITEMS	SPECIFICATIONS
Screen Diagonal [in]	21.5"
Pixels [lines]	1920∅ 1080
Active Area [mm]	476.64 (H) x 268.11 (V)
Pixel Pitch [mm]	0.24825 (H) x 0.24825 (V)
Pixel Arrangement	RGB vertical stripe
Weight [g] (Without the protection film)	585
Physical Size(COF/PWB included) [mm]	487.54(H) x 335.81(V) x 3(D) Typ.
Multi-cell glass Size [mm]	487.54(H) x 282.91(V) x 1.83(D) Typ
Display Mode	Normally White
Surface treatment (Without the protection film)	Anti-glare,3H

## 2. ABSOLUTE MAXIMUM RATINGS

### 2.1 ABSOLUTE RATINGS OF ENVIRONMENT

Item	Symbol	Value		Unit	Note
		Min.	Max.		
Storage Temperature	T <sub>ST</sub>	-20	+60	°C	(1), (3)
Operating Ambient Temperature	T <sub>OP</sub>	0	50	°C	(1), (2), (3)
Altitude Operating	A <sub>OP</sub>	0	5000	M	(3)
Altitude Storage	A <sub>ST</sub>	0	12000	M	(3)

Storage Condition: With shipping package.

Shelf life: one year

[Note 1] Temperature and relative humidity range is shown in the figure below.

\*1) 90 %RH Max. (Ta ≦ 40 °C).

\*2) Wet-bulb temperature should be 40 °C Max. (Ta > 40 °C).

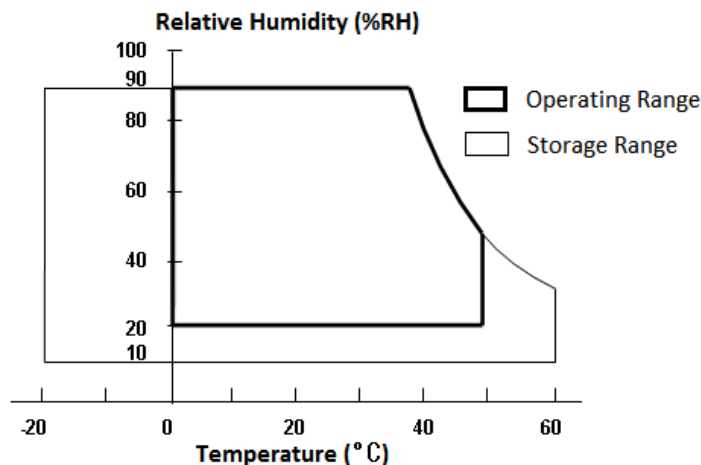

\*3) No condensation.

[Note 2] The maximum operating temperature is based on the test condition that the surface temperature of display area is less than or equal to 50°C with LCD module alone in a temperature controlled chamber. Thermal management should be considered in your product design to prevent the surface temperature of display area from being over 60°C. The range of operating temperature may degrade in case of improper thermal management in your product design.

[Note 3] The rating of environment is base on LCD module. Leave LCD cell alone, this environment condition can't be guaranteed. Except LCD cell, the customer has to consider the ability of other parts of LCD module and LCD module process.

### 3. ELECTRICAL CHARACTERISTICS

#### 3.1 Absolute Maximum Rating

Parameter	Symbol	Condition	Ratings	Unit	Remark
+5V supply voltage	VCC	Ta=25°C	0 ~ +6	V	
Storage temperature	Tstg	-	-20 ~ +60	°C	
Operation temperature	Topa	-	0 ~ +50	°C	

#### 3.2 Control circuit driving

Parameter		Symbol	Min	Typ	Max	Unit	Remark
+5V supply voltage	Supply voltage	VCC	4.5	5.0	5.5	V	[Note 1]
	Current dissipation	ICC	—	820	900	mA	VCC=5.0V,60Hz Black Pattern
		Irush	—	—	3	A	[Note 2]
Permissible input ripple voltage		VRP	—	—	300	mVp-p	VCC=5.0V
Differential Input Threshold Voltage	High	VTH	—	—	100	mV	VCM=1.2V
	Low	VTL	-100	—	—	mV	[Note 3]
Input Differential Voltage		VID	100	—	600	mV	
Differential Input Common Mode Voltage		VCM	1.0	1.2	1.5	V	
Power consumption		P	—	4.1	4.5	W	

[VCM]: Common mode voltage of LVDS driver

[Note1] Power, data sequence

$0.50\text{ms} \leq t1 \leq 10\text{ms}$	$t4 \geq 1 \text{ sec}$
$0.01\text{ms} < t2 \leq 50\text{ms}$	$t5 \geq 500\text{ms}$
$0.01\text{ms} < t3 \leq 50\text{ms}$	$t6 \geq 200\text{ms}$

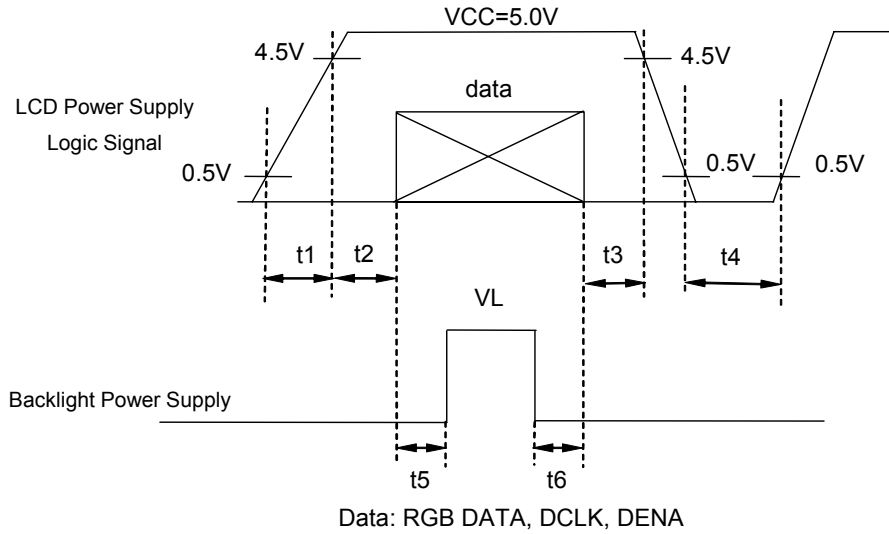

- ※ Data: CLKIN±, RIN0±, RIN1±, RIN2±, RIN3±
- ※ About the relation between data input and back light lighting, please base on the above-mentioned input sequence.
- ※ When back light is switched on before panel operation or after a panel operation stop, it may not display normally. But this phenomenon is not based on change of an incoming signal, and does not give damage to a liquid crystal display.
- ※ VCC-dip conditions:
  - (1) When  $3.6V \leq VCC(\min) < 4.5V$ ,  $t_d \leq 10\text{ ms}$
  - (2) When  $VCC < 3.6\text{ V}$ , VCC-dip conditions should also follow the VCC-turn-on conditions.

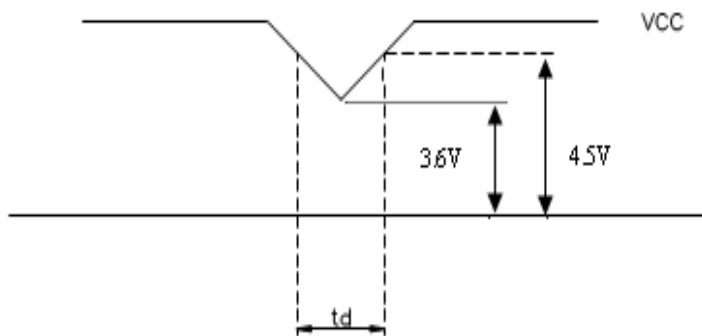

[Note2]

Irush Measurement Condition:

The duration of rising time of power input is 470us.

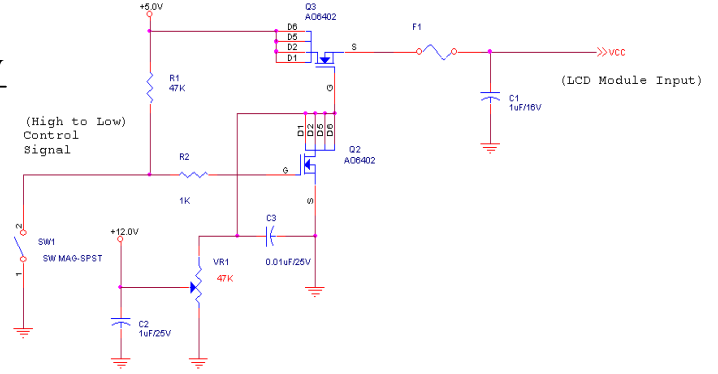
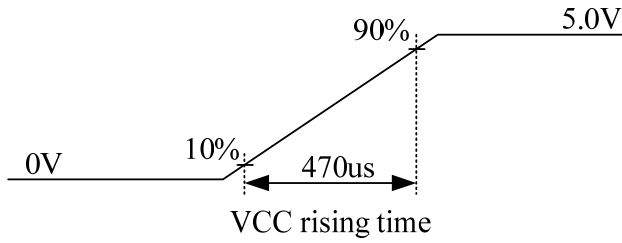

[Note3]

RIN+: Positive differential DATA & CLK Input

RIN -: Negative differential DATA & CLK Input

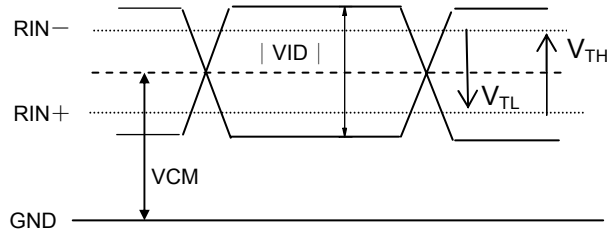
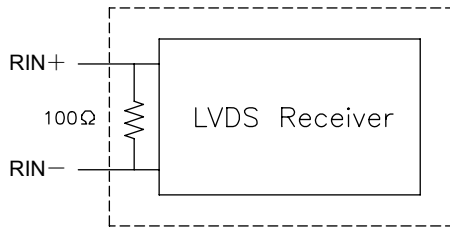

## 4. INTERFACE PIN CONNECTION

### 4.1 TFT LCD OPEN CELL

CN1 (Interface signals and +5V DC power supply) Shown on the next table.

Using connector: FI-XB30SSRLA-HF-16(JAE) or compatible

Matching connector: FI-X30HL(JAE) or compatible

Pin No.	Symbol	Function	Remark
1	RxOIN0-	Negative LVDS DATA input(ODD)	LVDS
2	RxOIN0+	Positive LVDS DATA input(ODD)	LVDS
3	RxOIN1-	Negative LVDS DATA input(ODD)	LVDS
4	RxOIN1+	Positive LVDS DATA input(ODD)	LVDS
5	RxOIN2-	Negative LVDS DATA input(ODD)	LVDS
6	RxOIN2+	Positive LVDS DATA input(ODD)	LVDS
7	GND	Ground	
8	RxOCLK-	Negative LVDS Clock input(ODD)	LVDS
9	RxOCLK+	Positive LVDS Clock input(ODD)	LVDS
10	RxOIN3-	Negative LVDS DATA input(ODD)	LVDS
11	RxOIN3+	Positive LVDS DATA input(ODD)	LVDS
12	RxEIN0-	Negative LVDS DATA input(EVEN)	LVDS
13	RxEIN0+	Positive LVDS DATA input(EVEN)	LVDS

14	GND	Ground	
15	RxEIN1-	Negative LVDS DATA input(EVEN)	LVDS
16	RxEIN1+	Positive LVDS DATA input(EVEN)	LVDS
17	GND	Ground	
18	RxEIN2-	Negative LVDS DATA input(EVEN)	LVDS
19	RxEIN2+	Positive LVDS DATA input(EVEN)	LVDS
20	RxCLK-	Negative LVDS Clock input(EVEN)	LVDS
21	RxCLK+	Positive LVDS Clock input(EVEN)	LVDS
22	RxEIN3-	Negative LVDS DATA input(EVEN)	LVDS
23	RxEIN3+	Positive LVDS DATA input(EVEN)	LVDS
24	GND	Ground	
25	NC	No connection(Do not connect)	
26	NC	No connection(Do not connect)	
27	NC	No connection(Do not connect)	
28	VDD	POWER +5V	
29	VDD	POWER +5V	
30	VDD	POWER +5V	



4.2 Block Diagram (Open-cell)

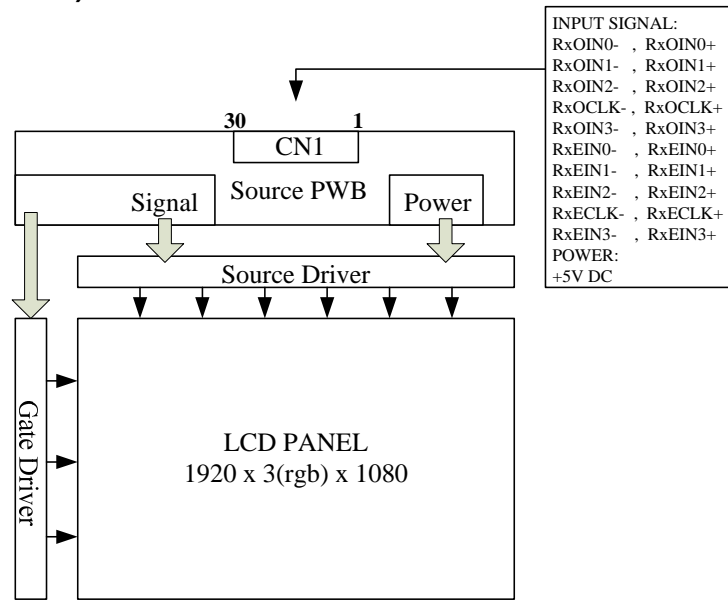

4.3 LVDS INTERFACE

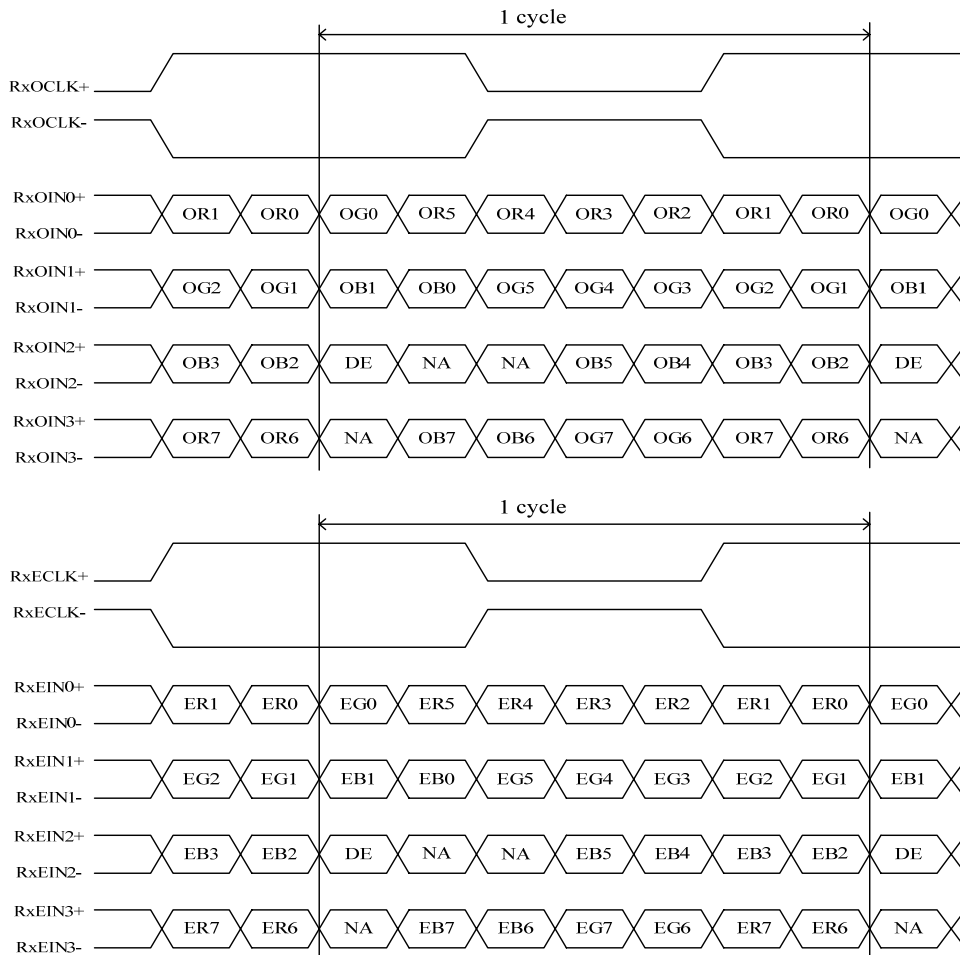

DE: Display Enable

NA: Not Available (Fixed Low)

R/G/B Data 7:MSB , R/G/B Data 0:LSB , O : “First Pixel Data” E : “Second Pixel Data”

4.4 COLOR DATA INPUT ASSIGNMENT

Colors & Gray scale	Gray Scale	Data signal																							
		R0	R1	R2	R3	R4	R5	R6	R7	G0	G1	G2	G3	G4	G5	G6	G7	B0	B1	B2	B3	B4	B5	B6	B7
Basic Color	Black	—	0	0	0	0	0	0	0	0	0	0	0	0	0	0	0	0	0	0	0	0	0	0	0
	Blue	—	0	0	0	0	0	0	0	0	0	0	0	0	0	0	0	1	1	1	1	1	1	1	1
	Green	—	0	0	0	0	0	0	0	0	1	1	1	1	1	1	1	0	0	0	0	0	0	0	0
	Cyan	—	0	0	0	0	0	0	0	0	1	1	1	1	1	1	1	1	1	1	1	1	1	1	1
	Red	—	1	1	1	1	1	1	1	1	0	0	0	0	0	0	0	0	0	0	0	0	0	0	0
	Magenta	—	1	1	1	1	1	1	1	1	0	0	0	0	0	0	0	1	1	1	1	1	1	1	1
	Yellow	—	1	1	1	1	1	1	1	1	1	1	1	1	1	1	1	0	0	0	0	0	0	0	0
	White	—	1	1	1	1	1	1	1	1	1	1	1	1	1	1	1	1	1	1	1	1	1	1	1
Gray Scale of Red	Black	GS0	0	0	0	0	0	0	0	0	0	0	0	0	0	0	0	0	0	0	0	0	0	0	
	↑	GS1	1	0	0	0	0	0	0	0	0	0	0	0	0	0	0	0	0	0	0	0	0	0	
	Darker	GS2	0	1	0	0	0	0	0	0	0	0	0	0	0	0	0	0	0	0	0	0	0	0	
	↑	↓					↓						↓								↓				
	↓	↓					↓						↓								↓				
	Brighter	GS253	1	0	1	1	1	1	1	1	0	0	0	0	0	0	0	0	0	0	0	0	0	0	
	↓	GS254	0	1	1	1	1	1	1	1	0	0	0	0	0	0	0	0	0	0	0	0	0	0	
	Red	GS255	1	1	1	1	1	1	1	1	0	0	0	0	0	0	0	0	0	0	0	0	0	0	
Gray Scale of Green	Black	GS0	0	0	0	0	0	0	0	0	0	0	0	0	0	0	0	0	0	0	0	0	0	0	
	↑	GS1	0	0	0	0	0	0	0	0	1	0	0	0	0	0	0	0	0	0	0	0	0	0	
	Darker	GS2	0	0	0	0	0	0	0	0	0	1	0	0	0	0	0	0	0	0	0	0	0	0	
	↑	↓					↓						↓								↓				
	↓	↓					↓						↓								↓				
	Brighter	GS253	0	0	0	0	0	0	0	0	1	0	1	1	1	1	1	0	0	0	0	0	0	0	
	↓	GS254	0	0	0	0	0	0	0	0	0	1	1	1	1	1	1	0	0	0	0	0	0	0	
	Green	GS255	0	0	0	0	0	0	0	0	1	1	1	1	1	1	1	0	0	0	0	0	0	0	
Gray Scale of Blue	Black	GS0	0	0	0	0	0	0	0	0	0	0	0	0	0	0	0	0	0	0	0	0	0		
	↑	GS1	0	0	0	0	0	0	0	0	0	0	0	0	0	0	0	1	0	0	0	0	0	0	
	Darker	GS2	0	0	0	0	0	0	0	0	0	0	0	0	0	0	0	0	1	0	0	0	0	0	
	↑	↓					↓						↓								↓				
	↓	↓					↓						↓								↓				
	Brighter	GS253	0	0	0	0	0	0	0	0	0	0	0	0	0	0	0	1	0	1	1	1	1	1	
	↓	GS254	0	0	0	0	0	0	0	0	0	0	0	0	0	0	0	0	1	1	1	1	1	1	
	Blue	GS255	0	0	0	0	0	0	0	0	0	0	0	0	0	0	0	1	1	1	1	1	1	1	

0: Low level voltage,

1: High level voltage.

Each basic color can be displayed in 256 gray scales from 8 bit data signals. According to the combination of total 24 bit data signals, the 16,7M colors display can be achieved on the screen.

## 5. INTERFACE TIMING

### 5.1 INPUT SIGNAL TIMING SPECIFICATIONS

(a) The input signal timing specifications are shown as the following table and timing diagram.

Item		Symbol	Min	Typ.	Max.	Unit		
LCD Timing	DCLK	Freq.	fCLK	55	72	90	MHz	
		Cycle	tCLK	18.18	13.89	11.11	ns	
	DE	Horizontal	Horizontal effective time	tHA	960	960	960	tCLK
			Horizontal blank time	tHB	32	100	115	tCLK
			Horizontal total time	tH	992	1060	1075	tCLK
		Vertical	Vertical frame Rate	Fr	50	60	75	Hz
			Vertical total time	tV	1084	1130	1170	tH
			Vertical effective time	tVA	1080	1080	1080	tH
		Vertical blank time	tVB	4	50	90	tH	

[Note]

- \*1) DE (data enable) usually is positive.
- \*2) DCLK still inputs during blanking.
- \*3) DE mode only.
- \*4) It may cause flicker at 50Hz.

(b) Timing Chart

#### a. Horizontal Signal

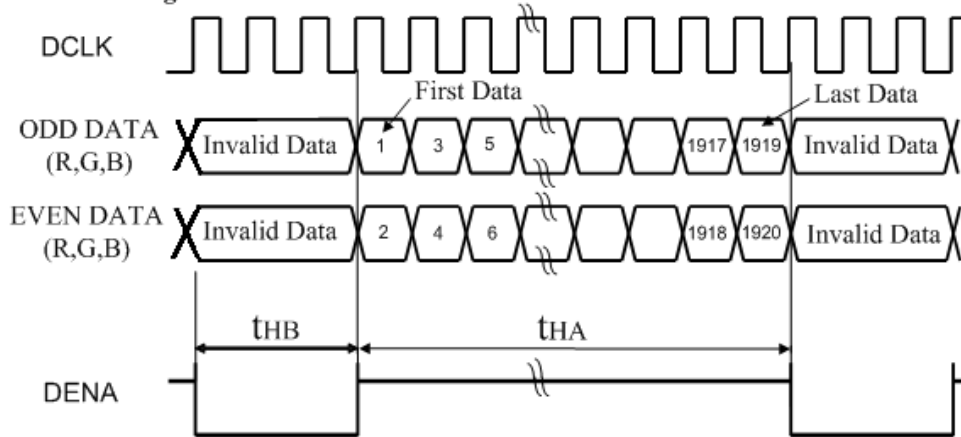

#### b. Vertical Signal

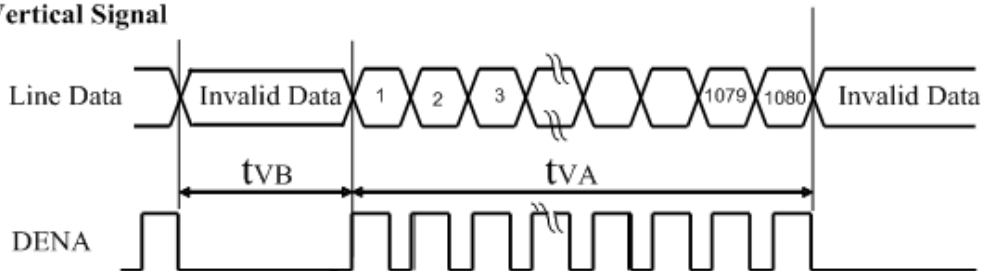

6. OPTICAL CHARACTERISTICS

6.1 OPTICAL SPECIFICATION

Ta=25°C

Parameter	Symbol	Condition	Min.	Typ.	Max.	Unit	Remark	
Viewing angle range	Horizontal	$\theta 21+\theta 22$	CR <sub>≥</sub> 10	160	170	-	Deg.	[Note1,4]
	Vertical	$\theta 11+\theta 12$		150	160	-	Deg.	
Contrast ratio	CR	$\theta =0 \text{ deg.}$	700	1000	-	-	[Note2,4]	
Response time	Tr+Tf		-	5	8	ms	[Note3,4]	
Chromaticity of white	x		0.283	0.313	0.343	-	[Note 4]	
	y		0.299	0.329	0.359	-		
Chromaticity of red	x		0.616	0.646	0.676	-		
	y		0.317	0.347	0.377	-		
Chromaticity of green	x		0.292	0.322	0.352	-		
	y		0.600	0.630	0.660	-		
Chromaticity of blue	x	0.125	0.155	0.185	-			
	y	0.031	0.061	0.091	-			

\*The measurement shall be executed 30 minutes after lighting at rating.

\*These values are measured with CPL standard back light unit.

\* The optical characteristics are measured using the following equipment.

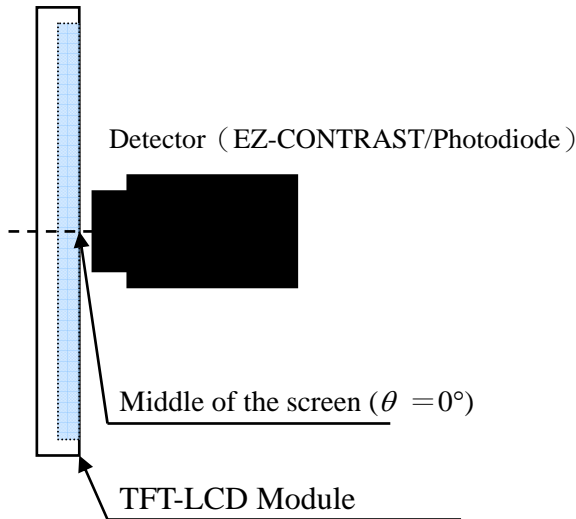

Measurement of viewing angle range, Response time.

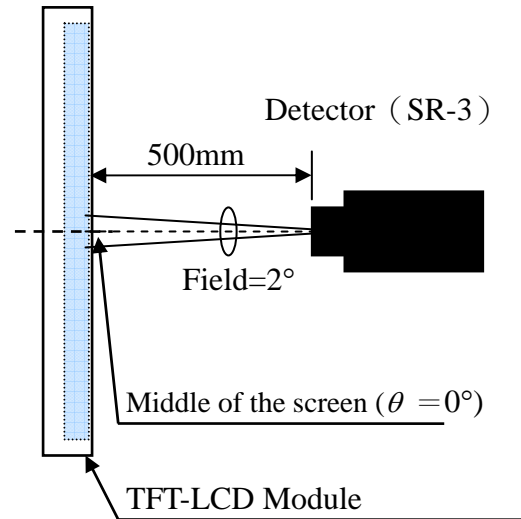

Measurement of Contrast, Luminance, Chromaticity.

[Note 1] Definitions of viewing angle range:

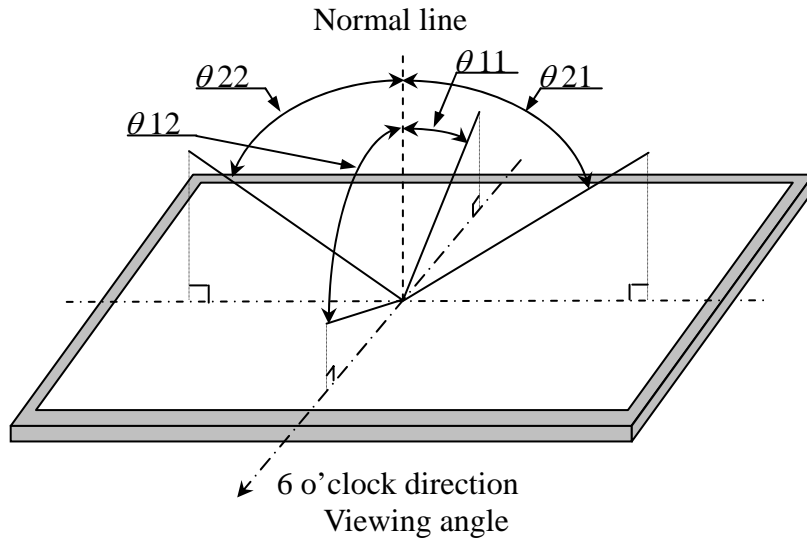

[Note 2] Definition of contrast ratio:

The contrast ratio is defined as the following.

$$\text{Contrast Ratio} = \frac{\text{Luminance (Brightness) with white screen}}{\text{Luminance (Brightness) with black screen}}$$

[Note 3] Definition of response time

The output signals of photo detector are measured when the input signals are changed from “Full White” to “Full Black” (rising time,  $T_r$ ), and from “Full Black” to “Full White” (falling time,  $T_f$ ), respectively. The response time is interval between the 10% and 90% (1 frame at 60 Hz) of amplitudes.

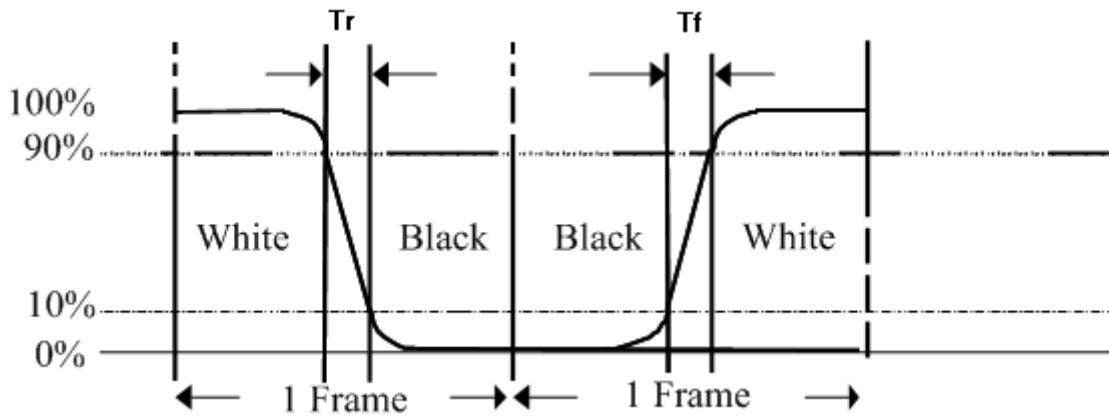

$$\text{Response time} = T_r + T_f$$

[Note 4] This shall be measured at center of the screen.

**6.2 FLICKER ADJUSTMENT**

(a) Adjustment Pattern: 2H1V Checker pattern as follow:

R 127	G 0	B 127	R 0	G 127	B 0	R 127	G 0	B 127	R 0	G 127	B 0	R 127	G 0	B 127	R 0	G 127	B 0
R 0	G 127	B 0	R 127	G 0	B 127	R 0	G 127	B 0	R 127	G 0	B 127	R 0	G 127	B 0	R 127	G 0	B 127
R 0	G 127	B 0	R 127	G 0	B 127	R 0	G 127	B 0	R 127	G 0	B 127	R 0	G 127	B 0	R 127	G 0	B 127
R 127	G 0	B 127	R 0	G 127	B 0	R 127	G 0	B 127	R 0	G 127	B 0	R 127	G 0	B 127	R 0	G 127	B 0
R 127	G 0	B 127	R 0	G 127	B 0	R 127	G 0	B 127	R 0	G 127	B 0	R 127	G 0	B 127	R 0	G 127	B 0
R 0	G 127	B 0	R 127	G 0	B 127	R 0	G 127	B 0	R 127	G 0	B 127	R 0	G 127	B 0	R 127	G 0	B 127
R 0	G 127	B 0	R 127	G 0	B 127	R 0	G 127	B 0	R 127	G 0	B 127	R 0	G 127	B 0	R 127	G 0	B 127

(b) Adjustment Method:

Flicker should be adjusted by turning the volume for flicker adjustment by the ceramic driver. It is adjusted to the point with least flickering of the whole screen. After making it surely overrun at once, it should be adjusted to the optimum point.

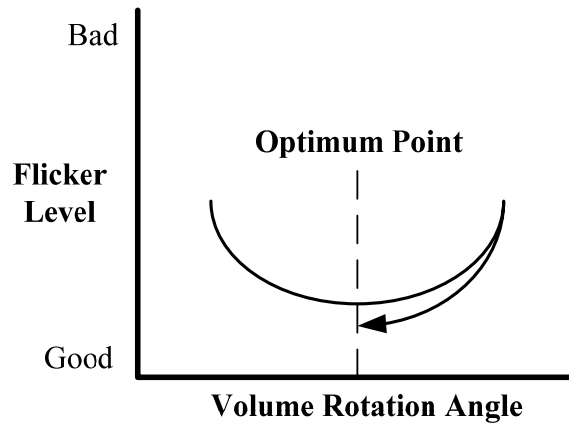

## 7. DEFINITIONS OF LABELS

### 7.1 Multi-cell LABEL

The label of Multi-cell sticks on the front side of the panel.

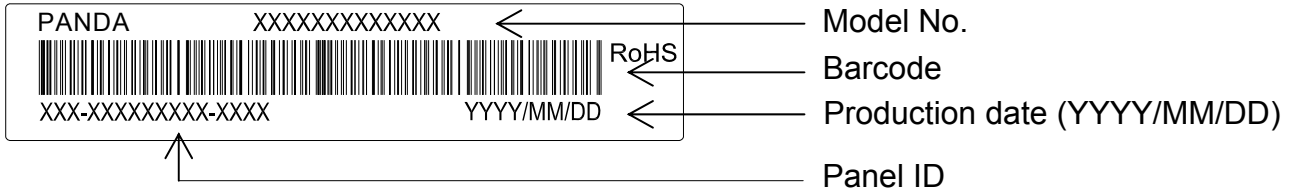

### 7.2 OPEN CELL LABEL

The label of Open-cell sticks on the non-component side of the PWB.

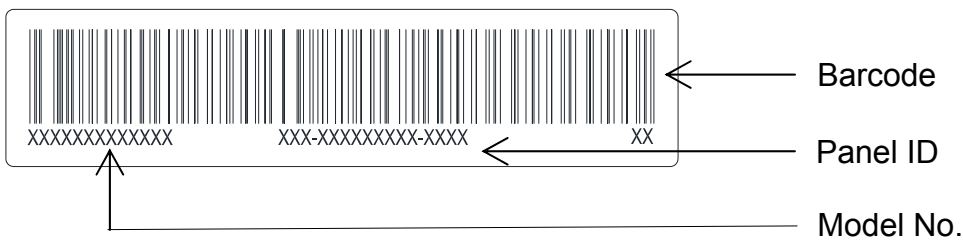

### 7.3 CELL BOX LABEL

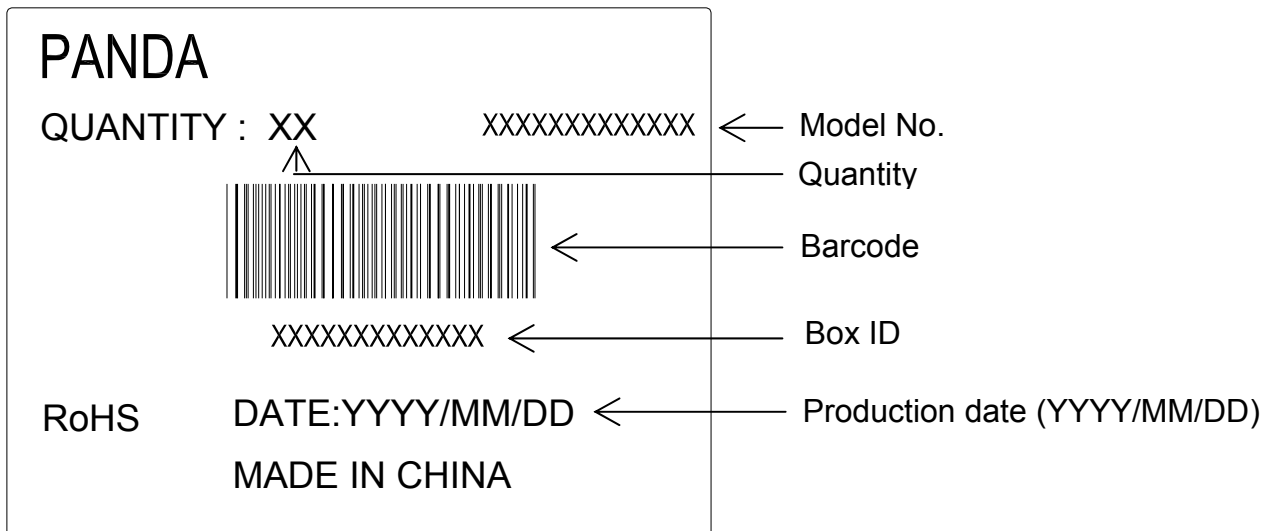

## 8. PACKING

### 8.1 PACKING SPECIFICATIONS

- |  |                       |
|--|-----------------------|
| (a) Piling number of EPS BOX                         | : 2x2 columns, 6 rows |
| (b) Packing quantity in one ESP BOX                  | : 20 pieces           |
| (c) EPS BOX size                                     | : 660mm*445mm*143mm   |
| (d) Pallet size                                      | : 1346mm*925mm*150mm  |
| (e) Total mass of one EPS BOX filled with full Panel | : 13.4 kg             |

### 8.2 PACKING METHOD

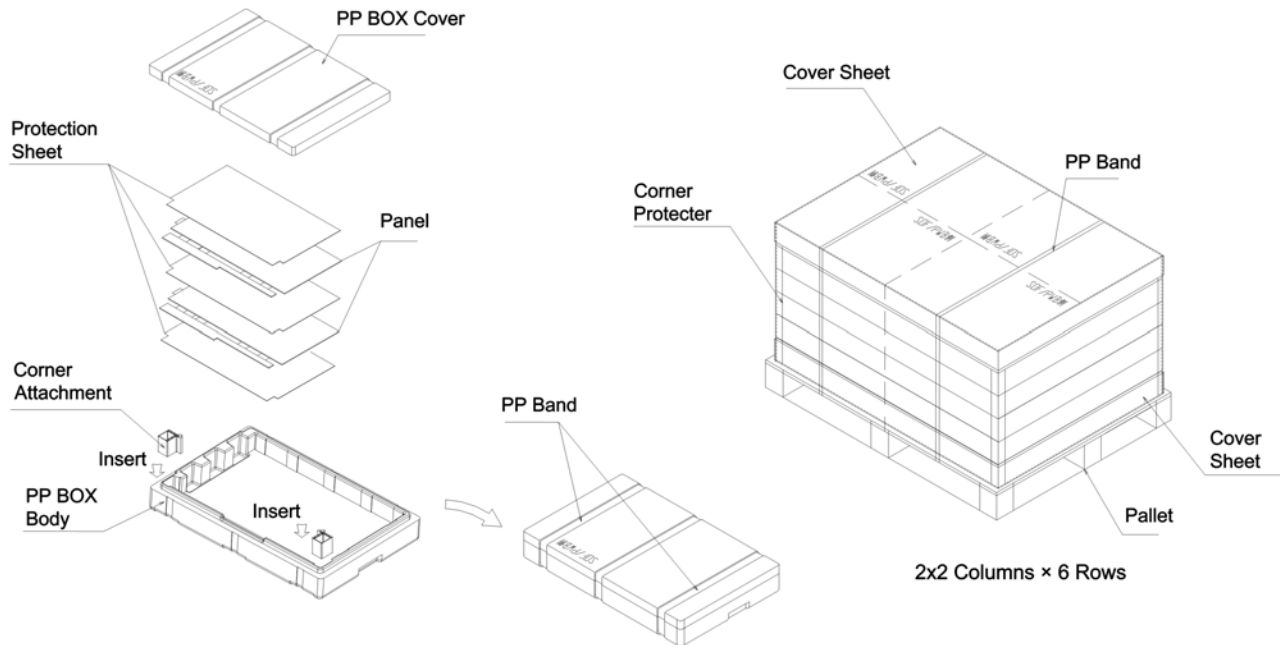

## 9. PRECAUTIONS

- Because the Open-Cell is too weak to destroy by static electricity, please don't touch the terminal with bare hands.
- Front polarizer can easily be damaged. Pay attention on it.
- Since long contact with drops of water may cause discoloration or spots, please wipe off them as soon as possible.
- When the panel surface is soiled, wipe it with absorbent cotton or other soft cloth.
- The Panel will be broken or chipped when it is dropped or bumped against a hard substance.
- Precautions of peeling off the Protection Film:
  - \*1) Be sure to peel off slowly (recommended more than 7 sec.) and constant speed.
  - \*2) Peeling direction shown in the next Fig.
  - \*3) Be sure to ground person with adequate methods such as the anti-static wrist band.
  - \*4) Be sure to connect PWB to GND while peeling off the protection film.
  - \*5) Ionized air should be blown to the surface while peeling off the protection film.
  - \*6) The protection film must not touch drivers and PWB.

After the protection film has been peeled off, some adhesive may be remained on the polarizer. Please use isopropyl-alcohol to remove it.



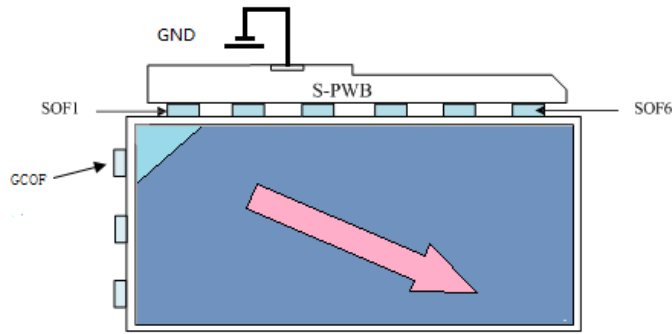

- (g) Since the Open-cell consists of TFT and electronic circuits with CMOS-ICs, which are very weak to electrostatic discharge, persons who are handling an Open-Cell should be grounded through adequate methods such as an anti-static wrist band. Connector pins should not be touched directly with bare hands.
- (h) Avoiding COF damage, do not bend PWB to display side when handling the open cell, recommend coating silicon or tuffy on front and back side of COF.

Reference: Process control standard of CPL.

item	Management standard value and performance standard
1 Anti-static mat(shelf)	1to50 [Mega ohm]
2 Anti-static mat(floor, desk)	1to100 [Mega ohm]
3 Ionizer	Attenuate from $\pm 1000V$ to $\pm 100V$ within two seconds.
4 Anti-static wrist band	0.8 to 10 [Mega ohm]
5 Anti-static wrist band entry and ground resistance	Below 1000 [ohm]
6 Temperature	22 to 26 [ $^{\circ}C$ ]
7 Humidity	60 to 70 [%]

- (i) Since the Open-cell has a PWB, please take care to keep it off any stress or pressure when handling or installing the Open-cell, otherwise some of electronic parts on them may be damaged.
- (j) Be sure to turn off the power supply when inserting or disconnecting the cable.
- (k) Be sure to design the module and cabinet so that the Open-cell van is installed without any extra stress such as warp or twist.
- (l) When handling and assembling Open-Cell into module, please be noted that long-term storage in the environment of oxidization or deoxidization gas and the use of materials such as reagent, solvent, adhesive, resin... etc, which generate these gasses, may cause corrosion and discoloration of the Open-Cell.
- (m) Applying too much force and stress to PWB and drivers may cause a malfunction electrically and mechanically.
- (n) The Open-cell has high frequency circuits. Sufficient suppression to EMI should be done by system manufactures.
- (o) Please be careful since image retention may occur when a fixed pattern is displayed for a long time.
- (p) The chemical compound, which causes the destruction of ozone layer, is not being used.
- (q) This Open-Cell module is corresponded to RoHS.
- (r) When any question or issue occurs, it shall be solved by mutual discussion.

## 10. Reliability test items

Test item	Condition
High temperature storage test	Ta= 60°C, 240h
Low temperature storage test	Ta=-20°C, 240h
High temperature and high humidity operation test	Ta= 50°C, 80%RH, 240h (No condensation)
High temperature operation test	Ta= 50°C, 240h
Low temperature operation test	Ta= 0°C, 240h
ESD(no operation)	Contact discharge on LVDS connector ±200V (200PF,0Ω)

[Result evaluation criteria]

Under the display quality test condition with normal operation state, there shall be no change, which may affect practical display function.

## 11. Mechanical Drawing

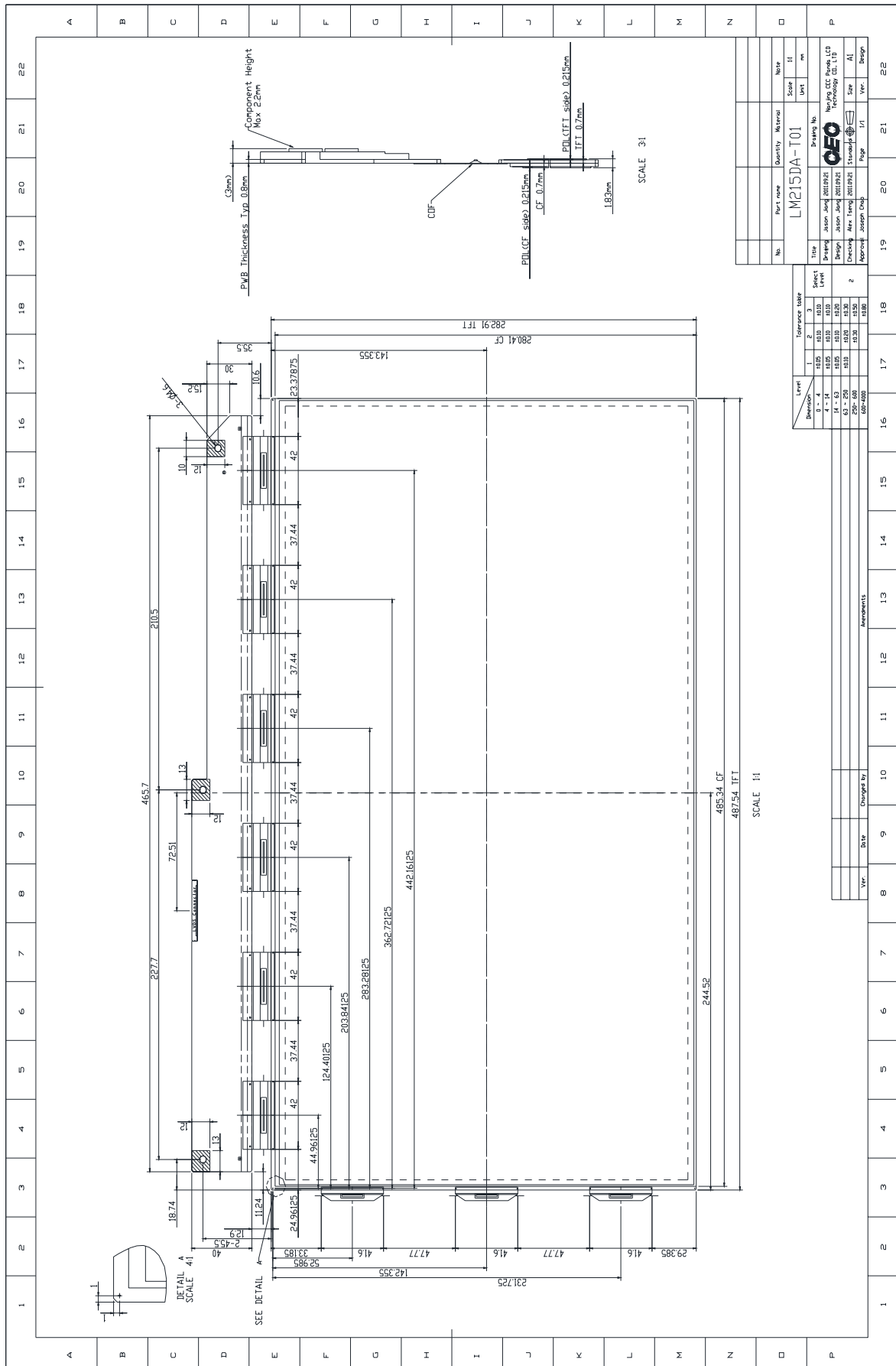

No.	Part name	Quantity	Material	Note	SI	mm
	LM215DA-T01					

Dimension	Level	Tolerance Value	Select Level
1 - 14	1	±0.05	1
14 - 16	2	±0.10	2
16 - 20	3	±0.15	3
20 - 22	4	±0.20	4

Level	Dimension	Value
1	1 - 14	±0.05
2	14 - 16	±0.10
3	16 - 20	±0.15
4	20 - 22	±0.20

Level	Dimension	Value
1	1 - 14	±0.05
2	14 - 16	±0.10
3	16 - 20	±0.15
4	20 - 22	±0.20

Level	Dimension	Value
1	1 - 14	±0.05
2	14 - 16	±0.10
3	16 - 20	±0.15
4	20 - 22	±0.20

Level	Dimension	Value
1	1 - 14	±0.05
2	14 - 16	±0.10
3	16 - 20	±0.15
4	20 - 22	±0.20

Level	Dimension	Value
1	1 - 14	±0.05
2	14 - 16	±0.10
3	16 - 20	±0.15
4	20 - 22	±0.20

Level	Dimension	Value
1	1 - 14	±0.05
2	14 - 16	±0.10
3	16 - 20	±0.15
4	20 - 22	±0.20