

TO: 众诚伟业

规格书编号

File No.

PN-RD-0006A

作成日 Issue Date:

2012年(Y)05月(M)12日(D)

改订日 Revision Date:

2012年(Y)08月(M)08日(D)

《新规
New《变更》
Revision

产品规格书

Product Specification

产品名
Product TFT-LCD Module

机种名
Model LM215DT1A

【接收印栏】

--

※ 本基准书由封面、附件等全 20 页构成。

如果对该规格书有异议, 请在下订单前提出。

※ This Product Specification have 20 pages including the coversheet and Appendices. Please negotiate the objection point before purchase order.

中电熊猫集团
南京中电熊猫液晶显示科技有限公司
研发中心 设计整合部

CEC PANDA GROUP

NANJING CEC PANDA LCD TECHNOLOGY CO., LTD.
R&D CENTER, DESIGN INTEGRATION SECTION.

部长	科长	主管	担当
林卓伟	李建邦 2012.8.8.		杨素文 2012.8.8

- CONTENTS -

1. GENERAL DESCRIPTION	4
1.1 OVERVIEW	4
1.2 CHARACTERISTICS	4
1.3 MECHANICAL SPECIFICATIONS	4
2. ABSOLUTE MAXIMUM RATINGS	4
2.1 ABSOLUTE RATINGS OF ENVIRONMENT	4
3. ELECTRICAL CHARACTERISTICS	5
3.1 ABSOLUTE MAXIMUM RATING	5
3.2 CONTROL CIRCUIT DRIVING	5
3.3 LED LIGHTBAR SPECIFICATION FOR BACKLIGHT	7
4. INTERFACE PIN CONNECTION	8
4.1 TFT LCD MODULE	8
4.2 BLOCK DIAGRAM	9
4.3 LVDS INTERFACE	9
4.4 COLOR DATA INPUT ASSIGNMENT	10
4.5 BACKLIGHT INTERFACE CONNECTION	11
4.6 BACKLIGHT UNIT	11
5. INTERFACE TIMING	12
5.1 INPUT SIGNAL TIMING SPECIFICATIONS	12
6. OPTICAL CHARACTERISTICS	12
6.1 OPTICAL SPECIFICATION	13
7. DEFINITION OF LABELS	15
7.1 MODULE LABEL	15
7.2 PACKING LABEL	15
8. PACKING	16
8.1 PACKING SPECIFICATIONS	16
8.2 PACKING METHOD	16
9. CARTON STORAGE CONDITION	17
10. PRECAUTIONS	17
10.1 ASSEMBLY AND HANDLING PRECAUTIONS	17
10.2 SAFETY PRECAUTIONS	18
11. RELIABILITY TEST ITEMS	18
12. MECHANICAL DRAWING	18

REVISION HISTORY

MODEL NO: LM215DT1A

DATE	NO.	REVISED No.	PAGE	SUMMARY	NOTE
2012/05/12	PN-RD-0006A	T 1.0	20	First Edition.	Tentative
2012/06/16	PN-RD-0006A	T 1.1	13,16	P13. Update the optical data. P16. Add carton storage condition.	
2012/08/08	PN-RD-0006A	V 1.0	5,13,16	P5.Modify the Spec. of t5 P13. Update the optical data. P16.Modify the storage method	Final

1. GENERAL DESCRIPTION

1.1 OVERVIEW

This module is color active matrix LCD module incorporating amorphous silicon TFT(Thin Film Transistor) LCD panel. It is composed of a color TFT-LCD panel, driver ICs, LED Backlight...etc. Graphics and texts can be displayed on a 1920×RGB×1080 dots panel with about 16.7M colors (R/G/B 6bits+Hi FRC data in each color) by using LVDS(Low Voltage Differential Signaling) to interface, +5V of DC supply voltage.

1.2 CHARACTERISTICS

CHARACTERISTICS ITEMS	SPECIFICATIONS
Screen Diagonal [in]	21.5"
Pixels [lines]	1920×1080
Active Area [mm]	476.64 (H) x 268.11 (V)
Pixel Pitch [mm]	0.24825 (H) x 0.24825 (V)
Pixel Arrangement	RGB vertical stripe
Display Mode	Normally White
Surface treatment (Without the protection film)	Anti-glare,3H

1.3 MECHANICAL SPECIFICATIONS

Item	Min.	Typ.	Max.	Unit	Remark	
Module Size	Horizontal (H)	495.1	495.6	496.1	mm	[Note 1]
	Vertical (V)	291.7	292.2	292.7	mm	[Note 1]
	Depth (D)	9.8	10.3	10.8	mm	[Note 1]
Weight		1780		g		

[Note 1] Please refer to the attached drawings for more information of front and back outline dimensions and the dimension of bosses are not included.

2. ABSOLUTE MAXIMUM RATINGS

2.1 ABSOLUTE RATINGS OF ENVIRONMENT

Item	Symbol	Value		Unit	Note
		Min.	Max.		
Storage Temperature	T _{ST}	-20	+60	°C	[Note 1,3]
Operating Ambient Temperature	T _{OP}	0	50	°C	[Note 1,2,3]

Storage Condition: With shipping package.

Shelf life: one year

[Note 1] Temperature and relative humidity range is shown in the figure below.

*1) 80 %RH Max. (T_a ≤ 40 °C).

*2) Wet-bulb temperature should be 40 °C Max. (T_a > 40 °C).

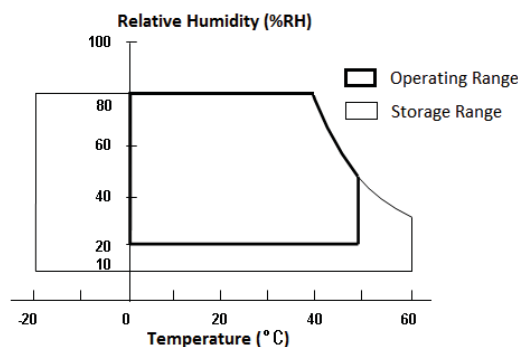

*3) No condensation.

[Note 2] The maximum operating temperature is based on the test condition that the surface temperature of display area is less than or equal to 50°C with LCD module alone in a temperature controlled chamber. Thermal management should be considered in your product design to prevent the surface temperature of display area from being over 60°C. The range of operating temperature may degrade in case of improper thermal management in your product design.

[Note 3] The rating of environment is base on LCD module. Leave LCD cell alone, this environment condition can't be guaranteed. Except LCD cell, the customer has to consider the ability of other parts of LCD module and LCD module process.

3. ELECTRICAL CHARACTERISTICS

3.1 ABSOLUTE MAXIMUM RATING

Parameter	Symbol	Condition	Ratings	Unit	Remark
+5V supply voltage	VCC	Ta=25°C	0 ~ +6	V	
Storage temperature	Tstg	-	-20 ~ +60	°C	
Operation temperature	Topa	-	0 ~ +50	°C	

3.2 CONTROL CIRCUIT DRIVING

Parameter		Symbol	Min	Typ	Max	Unit	Remark
+5V supply voltage	Supply voltage	VCC	4.5	5.0	5.5	V	[Note 1]
	Current dissipation	ICC	—	820	900	mA	VCC=5.0V,60Hz Black Pattern
		IRush	—	—	3	A	[Note 2]
Permissible input ripple voltage		VRP	—	—	300	mVp-p	VCC=5.0V
Differential Input Threshold Voltage	High	VTH	—	—	100	mV	VCM=1.2V [Note 3]
	Low	VTL	-100	—	—	mV	
Input Differential Voltage		VID	100	—	600	mV	
Differential Input Common Mode Voltage		VCM	1.0	1.2	1.5	V	
Power consumption		P	—	4.1	4.5	W	

[VCM]: Common mode voltage of LVDS driver.

[Note1] Power, data sequence

$0.50\text{ms} \leq t_1 \leq 10\text{ms}$	$t_4 \geq 1 \text{ sec}$
$0.01\text{ms} < t_2 \leq 50\text{ms}$	$t_5 \geq 500\text{ms}$
$0.01\text{ms} < t_3 \leq 50\text{ms}$	$t_6 \geq 200\text{ms}$

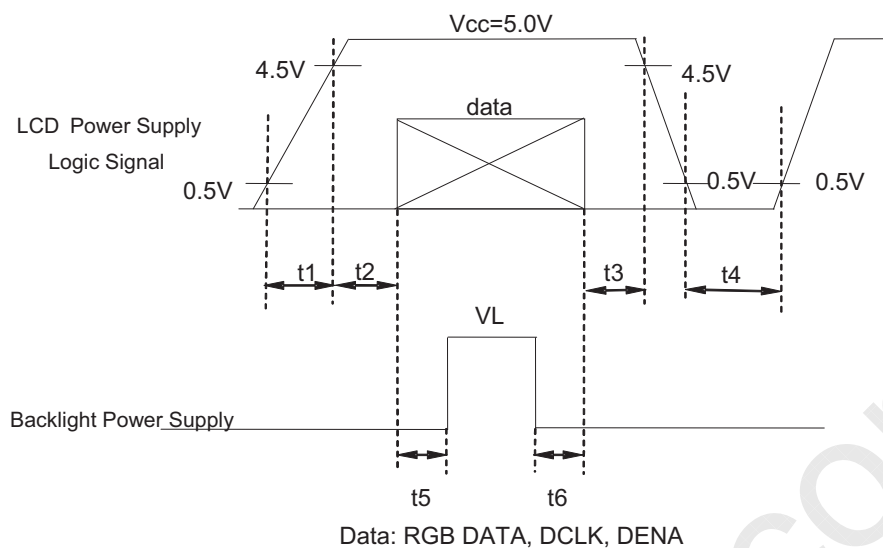

- ※ Data: CLKIN±, RIN0±, RIN1±, RIN2±, RIN3±
- ※ About the relation between data input and back light lighting, please base on the above-mentioned input sequence.
- ※ When back light is switched on before panel operation or after a panel operation stop, it may not display normally. But this phenomenon is not based on change of an incoming signal, and does not give damage to a liquid crystal display.
- ※ VCC-dip conditions:
 - (1) When $3.6V \leq VCC(\min) < 4.5V$, $t_d \leq 10$ ms
 - (2) When $VCC < 3.6$ V, VCC-dip conditions should also follow the VCC-turn-on conditions.

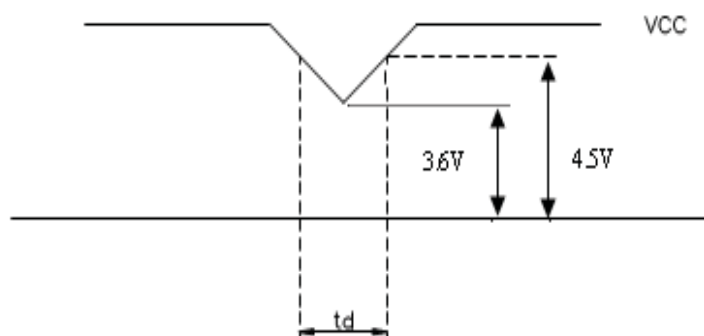

[Note2]

IRush Measurement Condition:

The duration of rising time of power input is 470us.

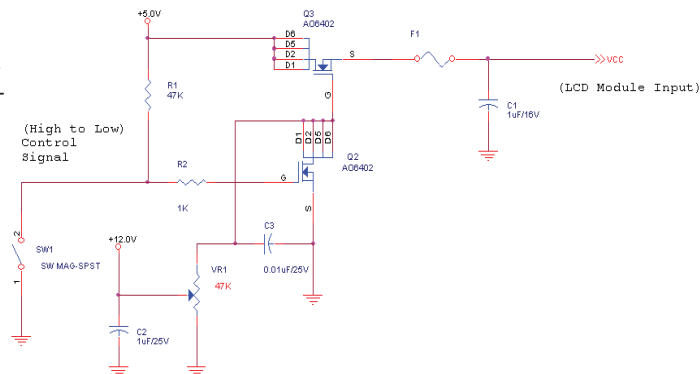
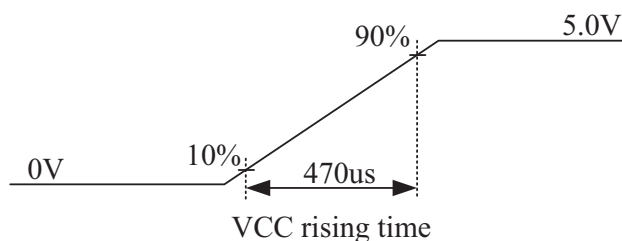

[Note3]

RIN+: Positive differential DATA & CLK Input

RIN -: Negative differential DATA & CLK Input

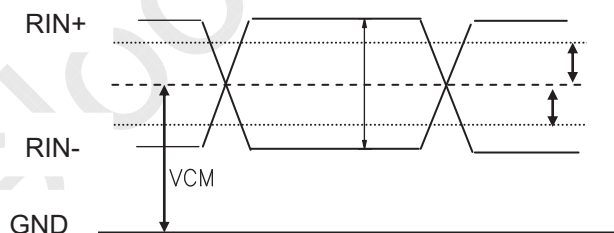
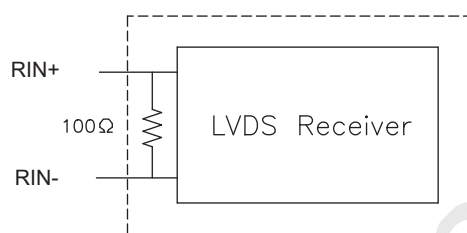

3.3 LED LIGHTBAR SPECIFICATION FOR BACKLIGHT

Parameter	Symbol	Value			Unit	Note
		Min.	Typ.	Max.		
Input Voltage	V_{pin}	43.5	49.5	54	VDC	Duty 100% [Note 1,3]
LED Light bar Current per input pin	I_{pin}	-	60	-	mADC	Duty 100% [Note 1,3]
LED Life Time	LT	30,000	-	-	hrs	[Note 2]
Power Consumption	PBL	10.44	-	12.96	W	
Dimming Duty Ratio	-	20	-	100	%	

[Note 1] Permanent damage to the device may occur if maximum values are exceeded. Function operation should be restricted to the conditions described under Normal Operating Conditions.

[Note 2] The life time of LED is defined as the time when it continues to operate under the condition at $T_a = 25 \pm 2^\circ\text{C}$ and $I_{pin} = 60 \text{ mA}$ until the brightness becomes $\leq 50\%$ of its original value.

[Note3] The backlight unit contains 1pcs lightbar.

4. INTERFACE PIN CONNECTION

4.1 TFT LCD MODULE

CN1 (Interface signals and +5V DC power supply) Shown on the next table.

Using connector: FI-XB30SSRLA-HF-16(JAE) or compatible

Matching connector: FI-X30HL(JAE) or compatible

Pin No.	Symbol	Function	Remark
1	RxOIN0-	Negative LVDS DATA input(ODD)	LVDS
2	RxOIN0+	Positive LVDS DATA input(ODD)	LVDS
3	RxOIN1-	Negative LVDS DATA input(ODD)	LVDS
4	RxOIN1+	Positive LVDS DATA input(ODD)	LVDS
5	RxOIN2-	Negative LVDS DATA input(ODD)	LVDS
6	RxOIN2+	Positive LVDS DATA input(ODD)	LVDS
7	GND	Ground	
8	RxOCLK-	Negative LVDS Clock input(ODD)	LVDS
9	RxOCLK+	Positive LVDS Clock input(ODD)	LVDS
10	RxOIN3-	Negative LVDS DATA input(ODD)	LVDS
11	RxOIN3+	Positive LVDS DATA input(ODD)	LVDS
12	RxEIN0-	Negative LVDS DATA input(EVEN)	LVDS
13	RxEIN0+	Positive LVDS DATA input(EVEN)	LVDS
14	GND	Ground	
15	RxEIN1-	Negative LVDS DATA input(EVEN)	LVDS
16	RxEIN1+	Positive LVDS DATA input(EVEN)	LVDS
17	GND	Ground	
18	RxEIN2-	Negative LVDS DATA input(EVEN)	LVDS
19	RxEIN2+	Positive LVDS DATA input(EVEN)	LVDS
20	RxCLK-	Negative LVDS Clock input(EVEN)	LVDS
21	RxCLK+	Positive LVDS Clock input(EVEN)	LVDS
22	RxEIN3-	Negative LVDS DATA input(EVEN)	LVDS
23	RxEIN3+	Positive LVDS DATA input(EVEN)	LVDS
24	GND	Ground	
25	NC	No connection(Do not connect)	
26	NC	No connection(Do not connect)	
27	NC	No connection(Do not connect)	
28	VDD	POWER +5V	
29	VDD	POWER +5V	
30	VDD	POWER +5V	

[Note 1] Pin1 start from left side.

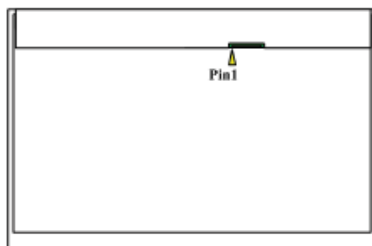

4.2 BLOCK DIAGRAM

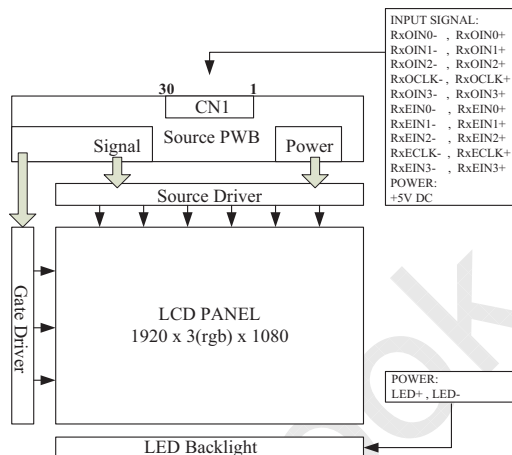

4.3 LVDS INTERFACE

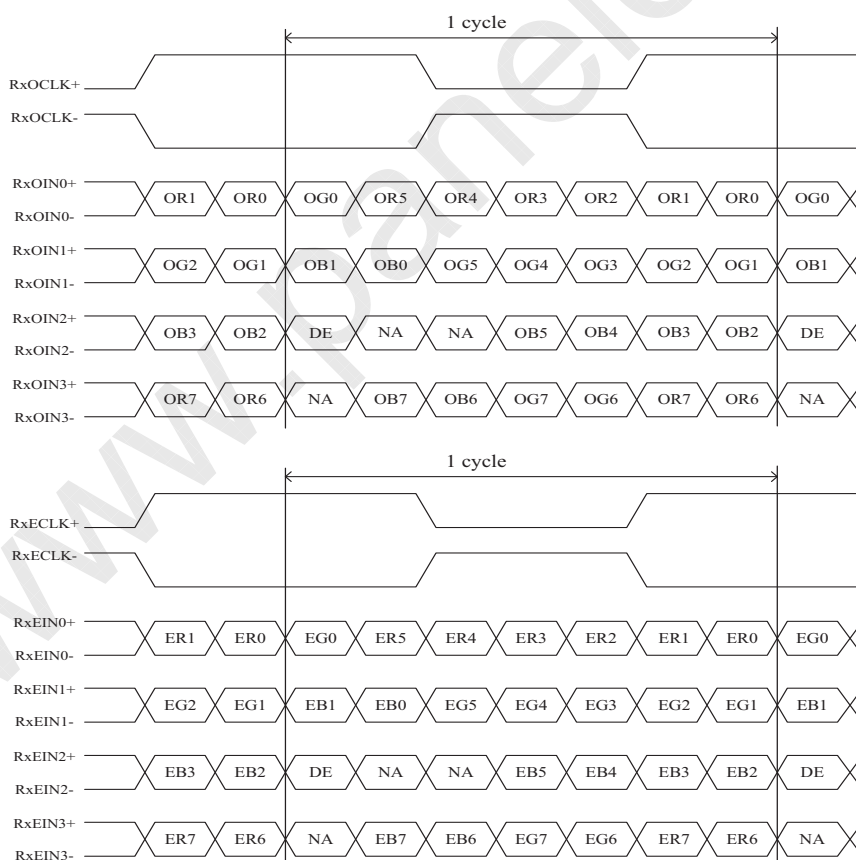

DE: Display Enable

NA: Not Available (Fixed Low)

R/G/B Data 7: MSB, R/G/B Data 0:LSB, O : "First Pixel Data" E : "Second Pixel Data"

4.4 COLOR DATA INPUT ASSIGNMENT

Colors & Gray scale	Gray Scale	Data signal																											
		R0	R1	R2	R3	R4	R5	R6	R7	G0	G1	G2	G3	G4	G5	G6	G7	B0	B1	B2	B3	B4	B5	B6	B7				
Basic Color	Black	—	0	0	0	0	0	0	0	0	0	0	0	0	0	0	0	0	0	0	0	0	0	0	0	0	0	0	
	Blue	—	0	0	0	0	0	0	0	0	0	0	0	0	0	0	0	0	1	1	1	1	1	1	1	1	1	1	
	Green	—	0	0	0	0	0	0	0	0	1	1	1	1	1	1	1	1	0	0	0	0	0	0	0	0	0	0	
	Cyan	—	0	0	0	0	0	0	0	0	1	1	1	1	1	1	1	1	1	1	1	1	1	1	1	1	1	1	
	Red	—	1	1	1	1	1	1	1	1	0	0	0	0	0	0	0	0	0	0	0	0	0	0	0	0	0	0	
	Magenta	—	1	1	1	1	1	1	1	1	0	0	0	0	0	0	0	0	1	1	1	1	1	1	1	1	1	1	
	Yellow	—	1	1	1	1	1	1	1	1	1	1	1	1	1	1	1	1	0	0	0	0	0	0	0	0	0	0	
	White	—	1	1	1	1	1	1	1	1	1	1	1	1	1	1	1	1	1	1	1	1	1	1	1	1	1	1	
Gray Scale of Red	Black	GS0	0	0	0	0	0	0	0	0	0	0	0	0	0	0	0	0	0	0	0	0	0	0	0	0	0		
	↑	GS1	1	0	0	0	0	0	0	0	0	0	0	0	0	0	0	0	0	0	0	0	0	0	0	0	0		
	Darker	GS2	0	1	0	0	0	0	0	0	0	0	0	0	0	0	0	0	0	0	0	0	0	0	0	0	0		
	↑	↓					↓							↓												↓			
	↓	↓					↓							↓												↓			
	Brighter	GS253	1	0	1	1	1	1	1	1	0	0	0	0	0	0	0	0	0	0	0	0	0	0	0	0	0		
	↓	GS254	0	1	1	1	1	1	1	1	0	0	0	0	0	0	0	0	0	0	0	0	0	0	0	0	0		
	Red	GS255	1	1	1	1	1	1	1	1	0	0	0	0	0	0	0	0	0	0	0	0	0	0	0	0	0		
Gray Scale of Green	Black	GS0	0	0	0	0	0	0	0	0	0	0	0	0	0	0	0	0	0	0	0	0	0	0	0	0	0		
	↑	GS1	0	0	0	0	0	0	0	0	1	0	0	0	0	0	0	0	0	0	0	0	0	0	0	0	0		
	Darker	GS2	0	0	0	0	0	0	0	0	0	1	0	0	0	0	0	0	0	0	0	0	0	0	0	0	0		
	↑	↓					↓							↓												↓			
	↓	↓					↓							↓												↓			
	Brighter	GS253	0	0	0	0	0	0	0	0	1	0	1	1	1	1	1	1	0	0	0	0	0	0	0	0	0		
	↓	GS254	0	0	0	0	0	0	0	0	0	1	1	1	1	1	1	1	0	0	0	0	0	0	0	0	0		
	Green	GS255	0	0	0	0	0	0	0	0	1	1	1	1	1	1	1	1	0	0	0	0	0	0	0	0	0		
Gray Scale of Blue	Black	GS0	0	0	0	0	0	0	0	0	0	0	0	0	0	0	0	0	0	0	0	0	0	0	0	0	0		
	↑	GS1	0	0	0	0	0	0	0	0	0	0	0	0	0	0	0	0	1	0	0	0	0	0	0	0	0		
	Darker	GS2	0	0	0	0	0	0	0	0	0	0	0	0	0	0	0	0	0	1	0	0	0	0	0	0	0		
	↑	↓					↓							↓												↓			
	↓	↓					↓							↓												↓			
	Brighter	GS253	0	0	0	0	0	0	0	0	0	0	0	0	0	0	0	0	1	0	1	1	1	1	1	1	1		
	↓	GS254	0	0	0	0	0	0	0	0	0	0	0	0	0	0	0	0	0	1	1	1	1	1	1	1	1		
	Blue	GS255	0	0	0	0	0	0	0	0	0	0	0	0	0	0	0	0	1	1	1	1	1	1	1	1	1		

0: Low level voltage,

1: High level voltage.

Each basic color can be displayed in 256 gray scales from 8 bit data signals. According to the combination of total 24 bit data signals, the 16,7M colors display can be achieved on the screen.

4.5 BACKLIGHT INTERFACE CONNECTION

LED light bar connector type : CI1406M1HRB-NH, manufactured by CVILUX.

Pin No.	Signal name
1	ILED (current out)
2	ILED (current out)
3	VLED (voltage in)
4	VLED (voltage in)
5	ILED (current out)
6	ILED (current out)

4.6 BACKLIGHT UNIT

The backlight unit contains one lightbar.

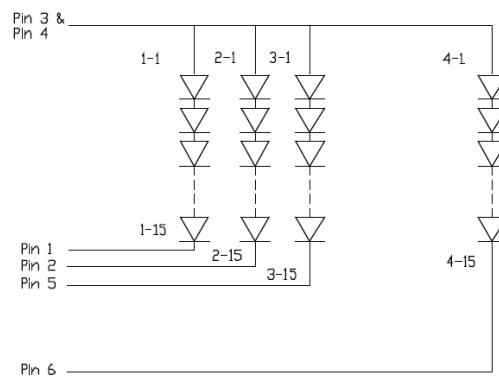

Electrical Circuit of lightbar

5. INTERFACE TIMING

5.1 INPUT SIGNAL TIMING SPECIFICATIONS

(a) The input signal timing specifications are shown as the following table and timing diagram.

Item			Symbol	Min	Typ.	Max.	Unit	
LCD Timing	DCLK		Freq.	fCLK	55	72	90	MHz
			Cycle	tCLK	18.18	13.89	11.11	ns
	DE	Horizontal	Horizontal effective time	tHA	960	960	960	tCLK
			Horizontal blank time	tHB	32	100	115	tCLK
			Horizontal total time	tH	992	1060	1075	tCLK
		Vertical	Vertical frame Rate	Fr	50	60	75	Hz
			Vertical total time	tV	1084	1130	1170	tH
			Vertical effective time	tVA	1080	1080	1080	tH
			Vertical blank time	tVB	4	50	90	tH

[Note]

- *1) DE (data enable) usually is positive.
- *2) DCLK still inputs during blanking.
- *3) DE mode only.
- *4) It maybe cause flicker at 50Hz.

(b) Timing Chart

a. Horizontal Signal

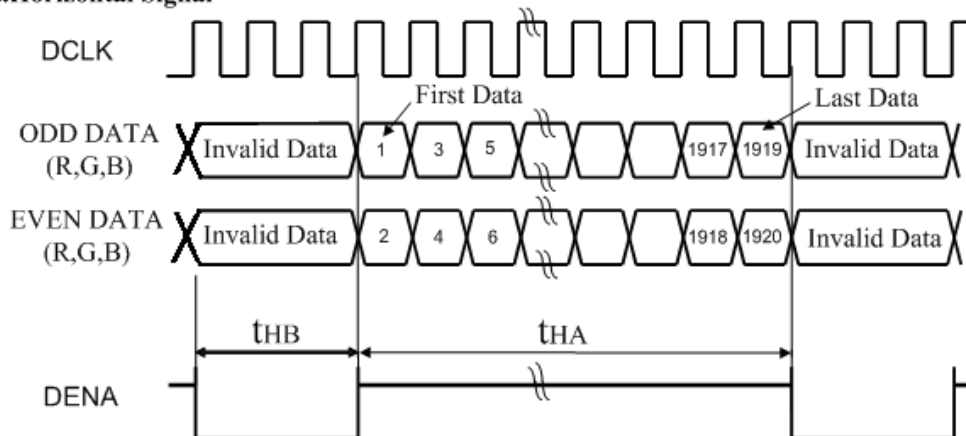

b. Vertical Signal

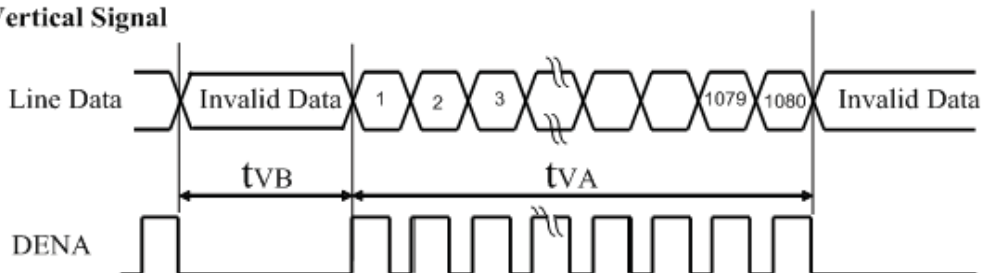

6. OPTICAL CHARACTERISTICS

6.1 OPTICAL SPECIFICATION

Ta=25°C

Parameter	Symbol	Condition	Min.	Typ.	Max.	Unit	Remark	
Luminance	L	$\theta = 0$ deg.	200	250		cd/m ²	[Note 1,4]	
Luminance uniformity	ΔL	$\theta = 0$ deg.	75			%	[Note 1,5]	
Contrast ratio	CR	$\theta = 0$ deg.	700	1000	-	-	[Note2,4]	
Response time	Tr+Tf		-	5	8	ms	Tr+Tf [Note3,4]	
Chromaticity of white	x		Typ-0.03	0.313	Typ+0.03	-	[Note 4]	
	y		Typ-0.03	0.329	Typ+0.03	-		
Chromaticity of red	x		Typ-0.03	0.645	Typ+0.03	-		
	y		Typ-0.03	0.348	Typ+0.03	-		
Chromaticity of green	x		Typ-0.03	0.327	Typ+0.03	-		
	y		Typ-0.03	0.624	Typ+0.03	-		
Chromaticity of blue	x	Typ-0.03	0.150	Typ+0.03	-			
	y	Typ-0.03	0.061	Typ+0.03	-			
Viewing angle range	Horizontal	$\theta 21 + \theta 22$	CR _≥ 10	160	170	-	Deg.	[Note1,4]
	Vertical	$\theta 11 + \theta 12$		150	160	-	Deg.	
Color Gamut	C.G	$\theta = 0$ deg.		72		%		

*The measurement shall be executed 30 minutes after lighting at rating.

* The optical characteristics are measured using the following equipment.

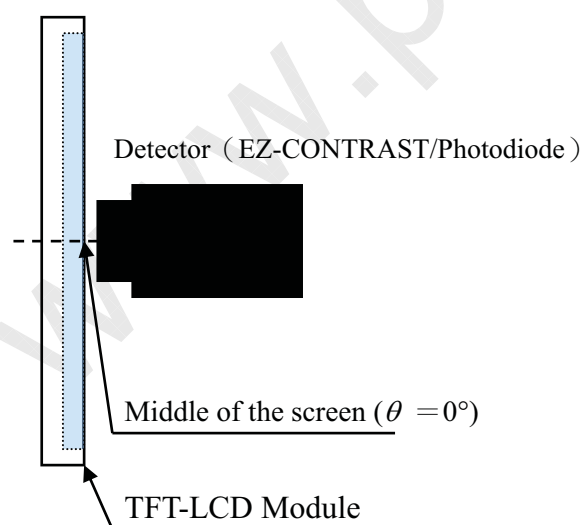

Measurement of viewing angle range, Response time.

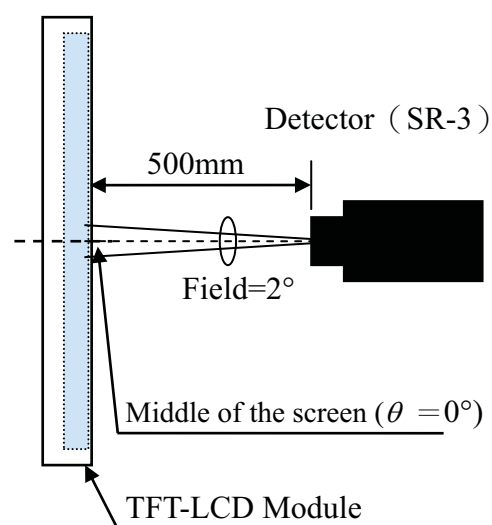

Measurement of Contrast, Luminance, Chromaticity.

[Note 1] Definitions of viewing angle range:

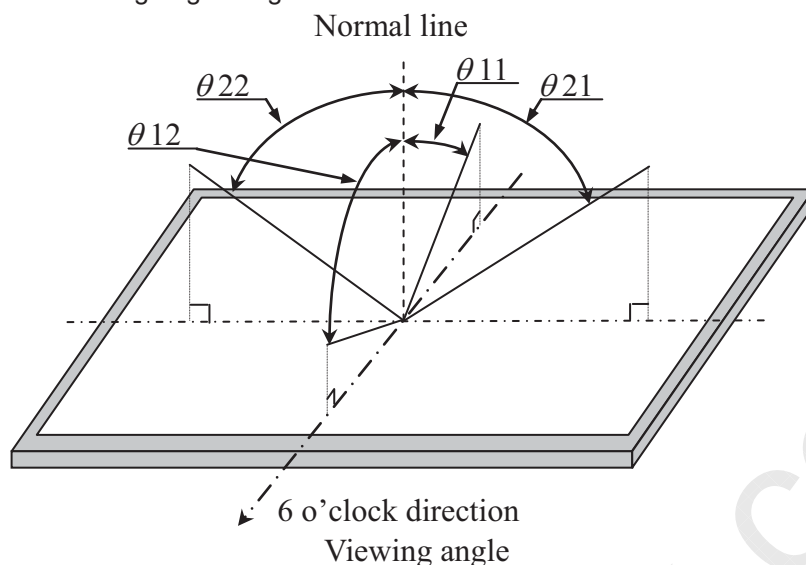

[Note 2] Definition of contrast ratio:

The contrast ratio is defined as the following.

$$\text{Contrast Ratio} = \frac{\text{Luminance (Brightness) with white screen}}{\text{Luminance (Brightness) with black screen}}$$

[Note 3] Definition of response time

The output signals of photo detector are measured when the input signals are changed from “Full White” to “Full Black” (rising time, TR), and from “Full Black” to “Full Black” (falling time, TF), respectively. The response time is interval between the 10% and 90% (1 frame at 60 Hz) of amplitudes.

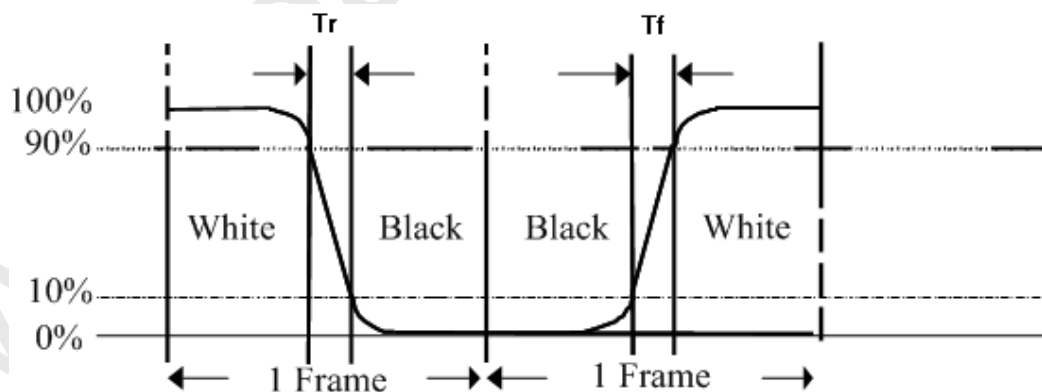

$$\text{Response time} = \text{Tr} + \text{Tf}$$

[Note 4] This shall be measured at center of the screen.

[Note 5] Definition of Luminance and Luminance uniformity:

Luminance: To measure at the center position “5” on the screen (NO.5).

Luminance uniformity: Lw (MAX) and Lw(MIN) are the maximum and minimum luminance value measure at the position “1~9” on the screen (NO.1~9) and the equation:

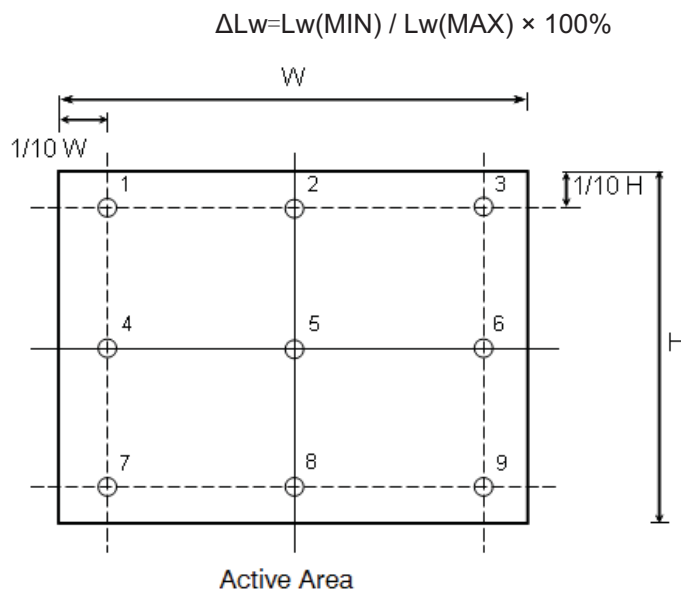

7. DEFINITION OF LABELS

7.1 MODULE LABEL

The label of displays, product model (LM215DT1A), and product label is stuck on the back side of the Module.



7.2 PACKING LABEL

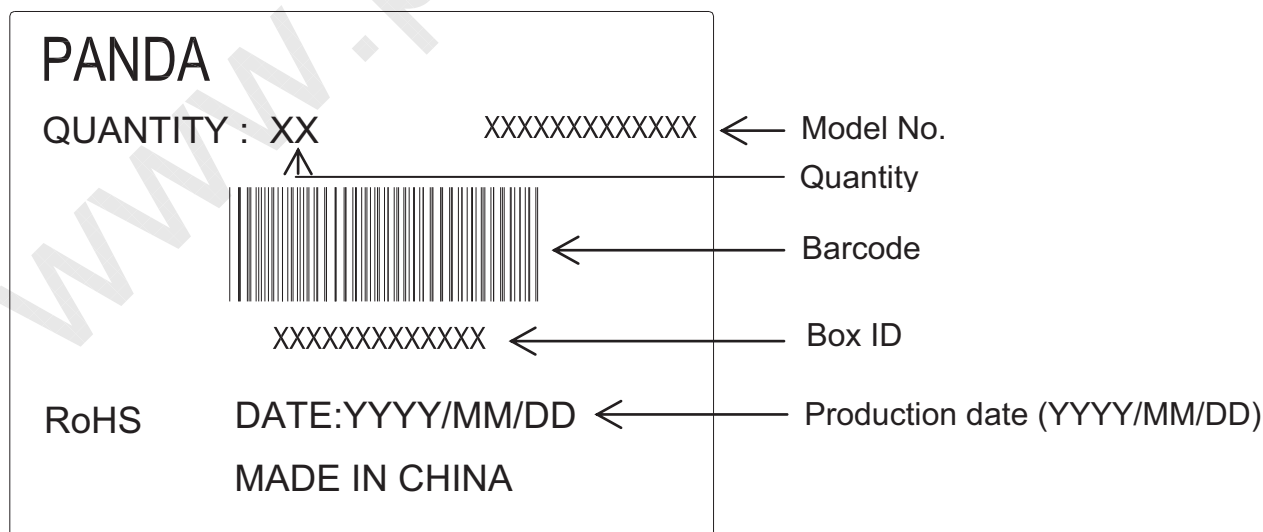

8. PACKING

8.1 PACKING SPECIFICATIONS

PILING NUMBER OF CARTON	8
Packing quantity in one carton	10 pcs
Carton size	569(L)x455(W)x387(H) mm
Pallet size	1200(L)x950(W)x150(H) mm
Total mass of one carton filled with full module	19.8 kg

8.2 PACKING METHOD

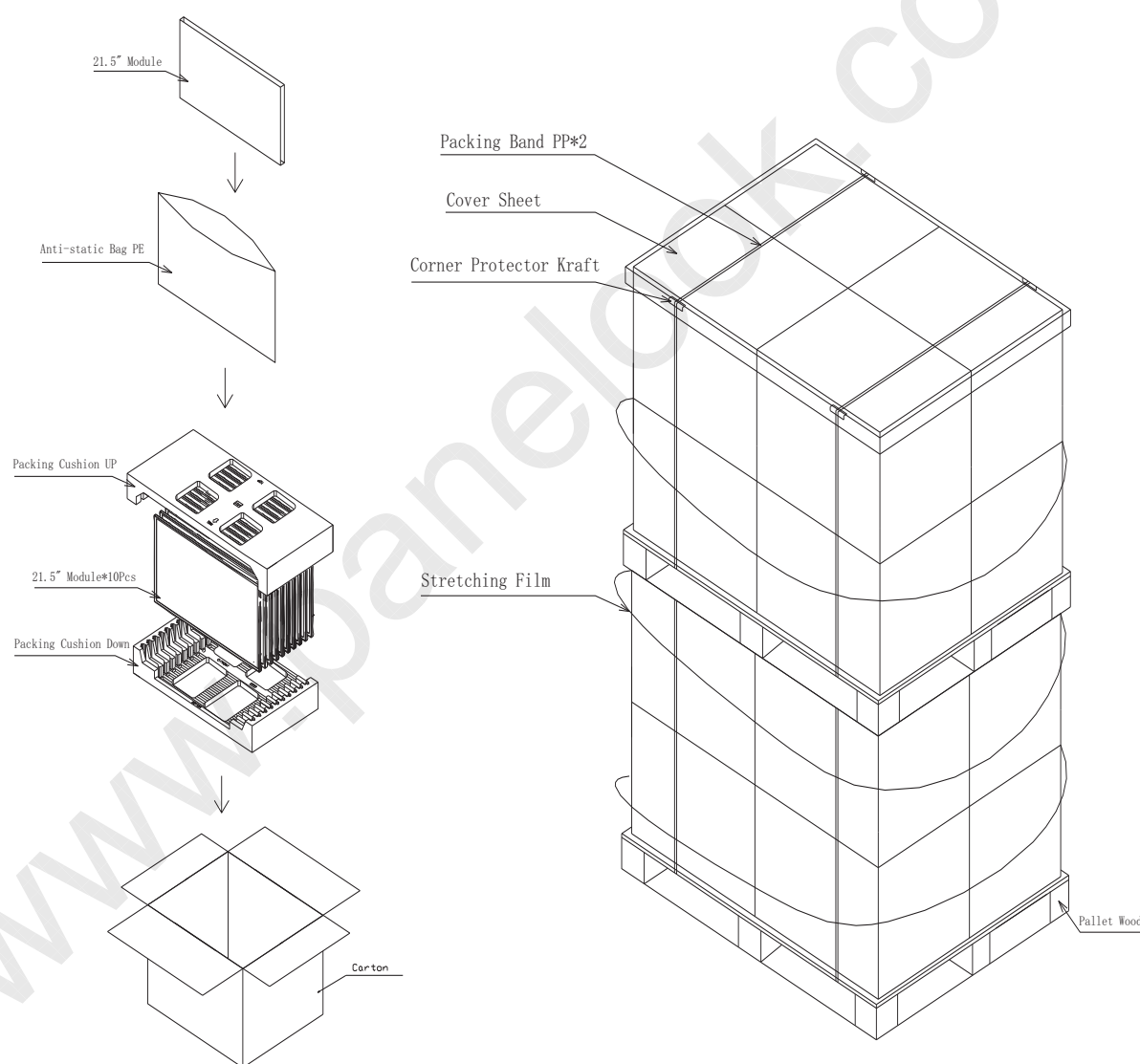

9. CARTON STORAGE CONDITION

Temperature: 0°C to 40°C

Humidity: 80%RH or less

Reference condition: 20°C to 35°C, 80%RH or less (summer)

5°C to 15°C, 80%RH or less (winter)

The total storage time (40°C, 80%RH): 240h or less

Sunlight Be sure to shelter a product from the direct sunlight.

Atmosphere Harmful gas, such as acid and alkali which bites electronic components and/or wires must not be detected.

Be sure to put cartons on palette or base, don't put it on floor, and store them with removing from wall. Please take care of ventilation in storehouse and around cartons, and control changing temperature is within limits of natural environment.

10. PRECAUTIONS

10.1 ASSEMBLY AND HANDLING PRECAUTIONS

- (a) Do not apply rough force such as bending or twisting to the module during assembly.
- (b) It is recommended to assemble or to install a module into the user's system in clean working areas. The dust and oil may cause electrical short or worsen the polarizer.
- (c) Since the LCM consists of TFT and electronic circuits with CMOS-ICs, which are very weak to electrostatic discharge, person who is handling an LCM should be grounded through adequate methods such as an anti-static wrist band. Connector pins should not be touched directly with bare hands.

Reference: Process control standard is shown as follow

	item	Management standard value and performance standard
1	Anti-static mat(shelf)	1to50 [Mega ohm]
2	Anti-static mat(floor, desk)	1to100 [Mega ohm]
3	Ionizer	Attenuate from $\pm 1000V$ to $\pm 100V$ within two seconds.
4	Anti-static wrist band	0.8 to 10 [Mega ohm]
5	Anti-static wrist band entry and ground resistance	Below 1000 [ohm]
6	Temperature	22 to 26 [°C]
7	Humidity	60 to 70 [%]

- (d) Do not apply pressure or impulse to the module to prevent the damage of LCD panel and backlight.
- (e) Always follow the correct power-on sequence when the LCD module is turned on. This can prevent the damage and latch-up of the CMOS LSI chips.
- (f) Be sure to turn off the power supply when inserting or disconnecting the cable.
- (g) Do not disassemble the module.
- (h) Front polarizer can easily be damaged, so please pay attention on it.
- (i) Using a absorbent cotton or other soft cloth without chemicals for cleaning, because the surface of polarizer is very soft and easily scratched.
- (j) Since long contact with drops of water may cause discoloration or spots, please wipe off them as soon as possible.
- (k) The Panel will be broken or chipped when it is dropped or bumped against a hard substance.

- (l) Applying too much force and stress to PWB and drivers may cause a malfunction electrically and mechanically.
- (m) Please be careful since image retention may occur when a fixed pattern is displayed for a long time.
- (n) Moisture can easily penetrate into LCD module and may cause the damage during operation.
- (o) High temperature or humidity may deteriorate the performance of LCD module. Please store LCD modules in the specified storage conditions.
- (p) This LCM is corresponded to RoHS.
- (q) When any question or issue occurs, it shall be solved by mutual discussion.

10.2 SAFETY PRECAUTIONS

- (a) If the liquid crystal material leaks from the panel, it should be kept away from the eyes or mouth. In case of contact with hands, skin or clothes, it has to be washed away thoroughly with soap.
- (b) After the module's end of life, it is not harmful in case of normal operation and storage.

11. Reliability test items

(a) Environment test condition(LCM)

Test item	Condition
High temperature storage test	Ta= 60°C, 240h
Low temperature storage test	Ta=-20°C, 240h
High temperature and high humidity storage test	Ta=50°C, 80%RH, 240h (No condensation)
High temperature operation test	Ta= 50°C, 240h
Low temperature operation test	Ta= 0°C, 240h
Thermal Shock Test	-20°C/30min, 60°C/30min, 100 cycles
On/Off Test	On/10sec, Off/10sec, 30,000 cycles

(b) Shock & Vibration (LCM)

Test item	Condition
Shock (Non-Operation)	Shock level: 50 Grms Waveform: half sine wave, 20ms Direction: $\pm X, \pm Y, \pm Z$ One time each direction
Vibration (Non-Operation)	Wave form: Random Vibration level: 1.5 Grms Bandwidth: 10-200 Hz Duration: X,Y,Z each direction per 30 min

[Result evaluation criteria]

Under the display quality test condition with normal operation state, there shall be no change, which may affect practical display function.

12. Mechanical Drawing

