

Product Specification

SPECIFICATION

For

APPROVAL

() Preliminary Specification

(◆) Final Specification

Title	22.0" WSXGA TFT LCD
-------	---------------------

BUYER NAME	General
MODEL NAME	

SUPPLIER	LG.Philips LCD Co.,Ltd.
MODEL NAME	LM220W1-A2MN

SIGNATURE	DATE
/	_____
/	_____
/	_____

APPROVED BY	DATE
S.H. Kang/G.Manager	_____
REVIEWED BY	
G.T. Kim/S.Engineer	_____
PREPARED BY	
K. N. Kim /Engineer	_____

Please return 1 copy for our confirmation with your signature and comments.

Product Engineering Dept.
LG.Philips LCD Co.,Ltd.

CONTENTS

NO.	ITEM	Page
-	COVER	1
-	CONTENTS	2
-	RECORD of REVISIONS	3
1.	GENERAL DESCRIPTIONS	4
2.	ABSOLUTE MAXIMUM RATINGS	5
3.	ELECTRICAL SPECIFICATIONS	5
3-1.	ELECTRICAL CHARACTERISTICS	5
3-2.	INTERFACE CONNECTIONS	6
3-3.	SIGNAL TIMING SPECIFICATIONS	8
3-4.	SIGNAL TIMING WAVEFORMS	9
3-5.	COLOR INPUT DATA REFERENCES	10
3-6.	POWER SEQUENCES	11
4.	OPTICAL SPECIFICATIONS	12
5.	MECHANICAL CHARACTERISTICS	16
6.	RELIABILITY	17
7.	INTERNATIONAL STANDARDS	18
7-1.	SAFETY	18
7-2.	EMC	18
8.	DESIGNATION OF LOT MARK	19
9.	PACKING FORM	19
10.	PRECAUTIONS	20
-	APPENDIX 1. SIGNAL MAPPING FOR Si1150 TMD5 Receiver	22
-	APPENDIX 2. OUTLINE DRAWINGS	23~24
-	APPENDIX 3. PACKING ASSEMBLY DRAWINGS	25~26

Record of Revisions

Version No.	Date	Page	Descriptions
0.0	SEP 20, 1998	-	First Draft, Preliminary
0.1	MAY 29, 1999	-	Second Draft, Preliminary
0.2	SEP 21, 1999	-	Preliminary update.
1.0	OCT 30, 1999	-	Final Draft

Product Specification

1. General Descriptions

The LM220W1 LCD is a Color Active Matrix Liquid Crystal Display with an integral Cold Cathode Fluorescent Lamp(CCFL) back light system. The matrix employs a-Si Thin Film Transistor as the active element. It is a transmissive type display operating in the normally black mode. This TFT-LCD has a 22.0 inch diagonally measured active display area with wide-SXGA resolution(1024 vertical by 1600 horizontal pixel array). Each pixel is divided into Red, Green and Blue sub-pixels or dots which are arranged in vertical stripes. Gray scale or the luminance of the sub-pixel color is determined with a 8-bit gray scale signal for each dot, thus, presenting a palette of more than 16,777,216 colors.

The LM220W1 has been designed to apply the TMDSTM(Transition Minimized differential Signaling) as the interface method to enables a simple and low-cost implementation in both the host and monitor.

The LM220W1 LCD is intended to support applications where high brightness, wide viewing angle, high color gamut, and high color depth are very important. In combination with the vertical arrangement of the sub-pixels, the LM220W1 characteristics provide an excellent flat panel display for office automation products such as monitors.

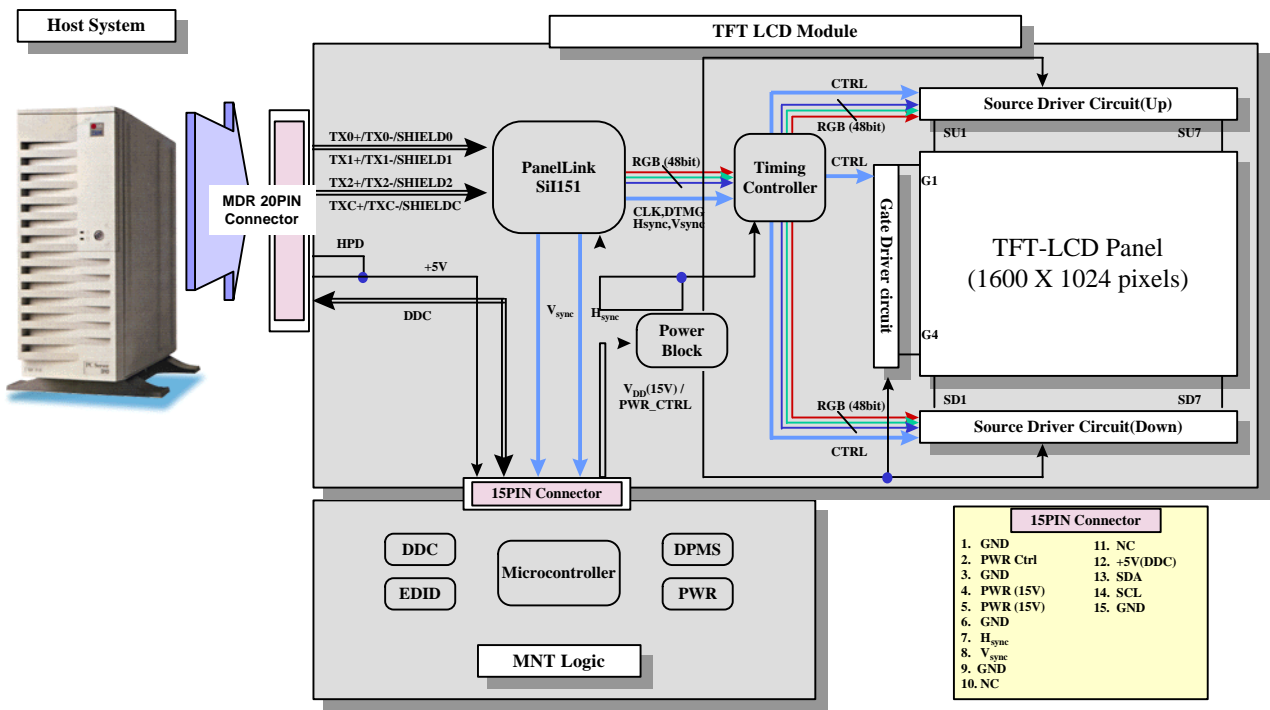

General Display Characteristics

Followings are general features of the model LM220W1 LCD;

Active display area	22.0 inches(56cm) diagonal
Outsize dimensions	542.0w * 375.0h * 35.3t(typ)mm(Without Inverter)
Pixel pitch	0.294 mm × 0.294 mm
Pixel format	1600 horiz. By 1024 vert. pixels RGB vertical stripe arrangement
Color depth	8-bit, 16,777,216 colors
Display operating mode	transmissive mode, normally black
Surface treatments	hard coating(3H), anti-glare treatment of the front polarizer
Interface method	TMDSTM interface using Si1151 chips and DFP connector
Lamps	Four (4) CCFL's

Product Specification
2. Absolute Maximum Ratings

Followings are maximum values which, if exceeded, may cause faulty operation or damage to the unit.

Table 1 Absolute Maximum Ratings

Parameter	symbol	Values		Units	Notes
		Min.	Max.		
Power Input Voltage	V_{DD}	0	+17.0	V_{DC}	at 25
Control Logic Voltage	V_I	0	+5.5V	V_{DC}	
Operating Temperature	T_{OP}	5	+50		1
Storage Temperature	T_{ST}	-20	+60		1

Note: 1. The Relative Humidity must not exceed 90% non-condensing at temperatures of 40 or less.
 At temperatures greater than 40 , the wet bulb temperature must not exceed 39 .

3. Electrical Specifications
3-1. Electrical Characteristics

The LM220W1 requires two power inputs. One input is employed to power the LCD electronics and to drive the voltages to drive the TFT array and liquid crystal. And the second input which powers the CCFL, is typically generated by an inverter. The inverter is an external unit to the LCD.

Table 2 Electrical Characteristics:

Parameter	Symbol	Values			Units	Notes
		Min.	Typ.	Max.		
MODULE:						
Power Supply Input Voltage	V_{DD}	14.25	15.0	16.5	V_{DC}	1
Power Supply Input Current	I_{DD}	-	0.8	1.0	A	
Control Logic Input High	V_{IH}	2.6	-	-	V_{DC}	V_{DC}
Control Logic Input Low	V_{IL}	-	-	0.8		
Control Logic Output High	V_{OH}	2.5	-	-		0.5
Control Logic Output Low	V_{OL}	-	-			
LAMP (each CCFL)						
Operating voltage	V_{BL}	1070	860	830	V_{RMS}	2
Operating Current	I_{BL}	3.0	8.0	9.0	mA	3
Established Starting Voltage						4
at 25		1400	-	-	V_{RMS}	
at 0		2100	-	-	V_{RMS}	
Operating Frequency		40	50	60	KHZ	
Life time	F_{BL}	15000	20000	-	hours	5

- Notes: 1. The input current shall be measured at V_{DD} of 15.0Vdc at 25 , refresh rate of 60Hz, and pixel clock frequency of 112.2MHz under full white pattern(256gray).
 2. This data is for reference for inverter design.
 3. The operating current shall be measured at the ground cable at ambient atmosphere of 25 and does not include loss of external inverter.
 4. These value are measured at both end of lamp and are for reference for inverter design.
 5. The life time is defined as the time at which brightness of lamp is 50% compare to that of initial value at the typical lamp current.

Product Specification

3-2. Interface Connections

Interface chip in host side, must be used TMDS™, part No. Sil150, designed by Silicon Image Inc., or its equivalent.

This LCD employs three kinds of interface connections. A 20 pin connector called by DFP connector, is used for TMDS signals from the host computer. This connector is fully compatible with DFP standard. Please, refer to Digital Flat Panel(DFP) standard for the detailed descriptions. A 15-pin connector is used for LCD module power and LCM controls signal from external monitor control circuits. And four connectors, a two pin connector, are used for the integral backlight system.

The pin configuration for the 20 pin DFP connector is shown in the table below.

Table 3 DFP CONNECTOR PIN CONFIGURATION (DFP Standard)

Pin	Symbol	Description	Pin	Symbol	Description
1	TX1+	TMDS positive differential output (channel1)	11	TX2+	TMDS positive differential output (channel2)
2	TX1-	TMDS negative differential output (channel1)	12	TX2-	TMDS negative differential output (channel2)
3	SHLD1	Shield for TMDS channel 1	13	SHLD2	Shield for TMDS channel 2
4	SHLDC	Shield for TMDS clock	14	SHLD0	Shield for TMDS channel 0
5	TXC+	TMDS positive differential output (reference clock)	15	TX0+	TMDS positive differential output (channel 0)
6	TXC-	TMDS negative differential output (reference clock)	16	TX0-	TMDS negative differential output (channel 0)
7	GND	Logic Ground	17	NC	Logic Ground
8	+5V	Logic +5V Supply (See note 2)	18	HPD	Hot Plug Detection (See note 3)
9	NC	No Connection	19	DDC_DAT	DDC2B Data (See note 4)
10	NC	No Connection	20	DDC_CLK	DDC2B Clock (See note 5)

- Notes: 1. All shield pins and GND(ground) pin should be connected together and should also be connected to the LCD's metal frame.
2. This +5V is only for external monitor control circuits and directly connected to 15 pin connector. The specifications for this source are the same as those defined in the VESA DDC Standard V3.0(+5V±5%, 50mA minimum, 1.0A maximum).
3. This pin is internally connected to pin 8 (+5V) in LCM circuits.
- 4, 5. These pins are only for external monitor control circuits and directly connected to 15 pin connector.
6. Refer to appendix 1 regarding TMDS signal mapping.

The following is a preliminary list of DFP compatible connectors.

1. 3M - Mini Delta Ribbon(MDR) Connector .050" series
 - a) Receptacle : P/N 10220-55G3 VC
 - b) Plug : P/N 10120-6000 EC
2. AMP
 - a) Receptacle : P/N 917738-2
 - b) Plug : P/N 2-175677-2
3. Molex
 - a) Receptacle : P/N 52515-2011
 - b) Plug : P/N 52316-2011

Please, contact connector manufacturer for detail description of this connector.

Product Specification

A 15 pin connector for external monitor control circuits, is a model 53261 manufactured by Molex. The mating connector part number is 51021 or its equivalent. The pin configuration for this connector is shown in the table below.

Table 4 15 PIN CONNECTOR PIN CONFIGURATION

Pin	Symbol	Description	Notes
1	GND	Ground	1
2	PWR_CTRL	LCM power control input signal Low : LCM power down except Sil151 receiver High : Normal operation mode	2
3	GND	Ground	
4	V _{DD}	LCM power supply, +15V±5%	
5	V _{DD}	LCM power supply, +15V±5%	
6	GND	Ground	
7	H _{SYNC}	H _{SYNC} out from Sil151 receiver	
8	V _{SYNC}	V _{SYNC} out from Sil151 receiver	
9	GND	Ground	
10	NC	No connection (Reserved)	
11	NC	No connection (Reserved)	
12	+5V_DDC	+5V out for DDC	3
13	SDA	DDC data line out	
14	SCL	DDC clock line out	
15	GND	Ground	

- Notes:
1. All GND(ground) pins should be connected together and should also be connected to the LCD's metal frame.
 2. LCM power control input signal for power saving mode. If this pin is held low state, LCM goes to power saving mode except Sil151 receiver.
 3. Pin 12, 13, 14 are for DDC2B communication between host computer and external monitor control circuits. These pins are directly connected to 20 pin DFP connector.

The backlight interface connector is a model BHSR-02VS-1, manufactured by JST. The mating connector part number is SM02B-BHS-1 or equivalent. The pin configuration for the connector is shown in the table below.

Table 5 BACKLIGHT CONNECTOR PIN CONFIGURATION

Pin	Symbol	Description	Notes
1	HV	Lamp power input	1
2	LV	Ground	2

- Notes:
1. The input power terminal is colored pink. Ground pin color is light pink.
 2. The backlight ground should be common with LCD metal frame.

Product Specification
3-3.Signal Timing Specifications

This is signal timing required at the input of the TMDS transmitter. All of the interface signal timing should be satisfied with the following specifications for it's proper operation.

Table 6 Timing Table

Parameter		Symbol	Value			Units	Notes
			Min.	Typ.	Max.		
Main Clock	Frequency	f_{CLK}	-	112.27	-	MHz	1
		t_{CLK}	-	8.91	-	ns	
Hsync	Period	t_{HP}	-	16.1	-	clock	2
	Pulse Width	t_{WH}	1799	1808	1817	clock	
Vsync	Period	t_{VP}	-	16.68	-	msec	3
	Pulse Width	t_{WV}	1031	1036	1041	lines	
Data Enable	Horizontal Back Porch	t_{HBP}	32	88	-	clock	4
	Horizontal Active Data	t_{HDE}	1600	1600	1600	clock	
	Horizontal Front porch	t_{HFP}	32	104	-	clock	
	Vertical Back Porch	t_{VBP}	1	1	-	lines	
	Vertical Active Data	t_{VDE}	1024	1024	1024	lines	
	Vertical Front porch	t_{VFP}	2	10	-	lines	

- Notes: 1. Please, refer Sil150 data sheets for the detailed timing condition (required setup, hold time and etc.) between video processor and Sil150 TMDS transmitter.
2. Horizontal sync shall be active high.
3. Vertical sync shall be active high.
4. Data enable shall be active high

Product Specification

3-4. Signal Timing Waveforms

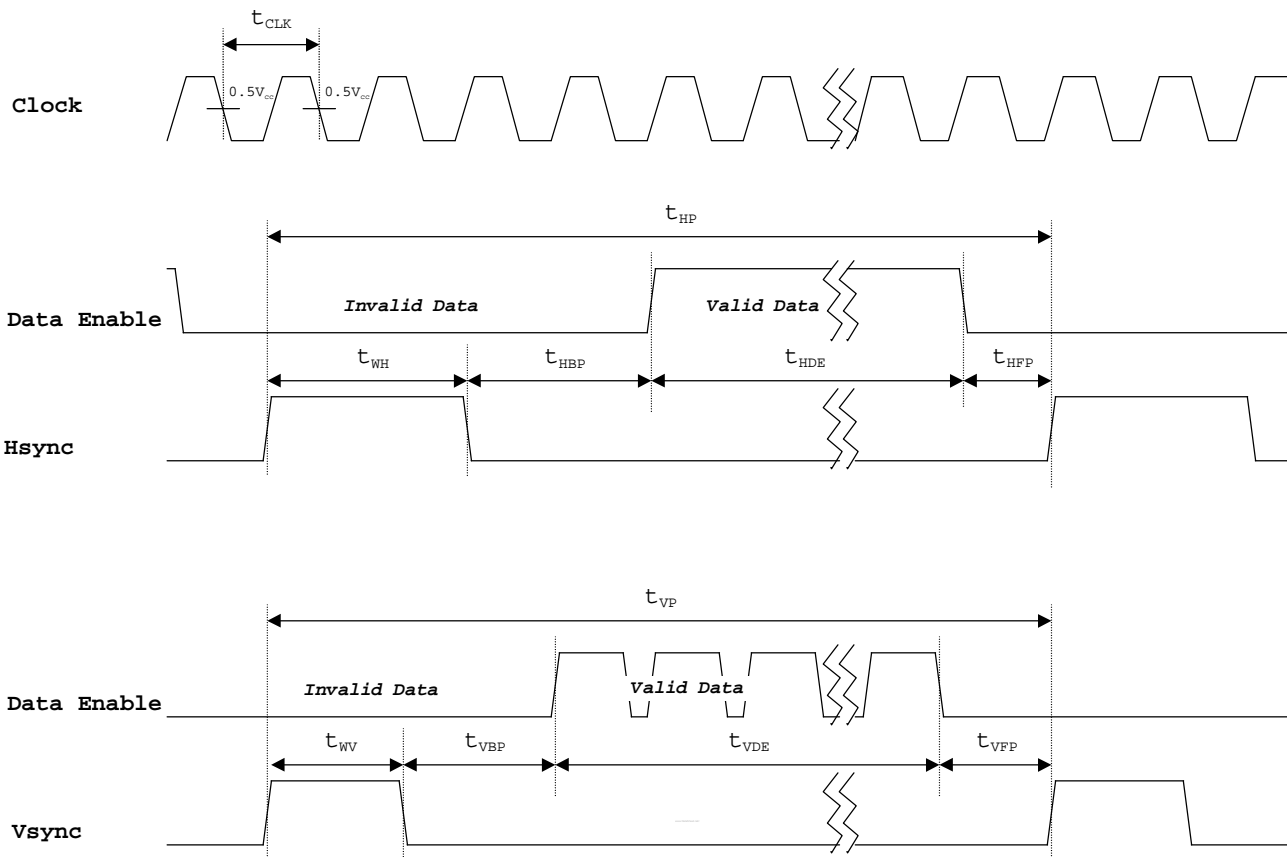

Product Specification

3-5. Color Input Data References

The brightness of each primary color(red, green and blue) is based on the 8-bit gray scale data input for the color; the higher the binary input, the brighter the color. The table below provides a reference for color versus data input.

Table 7 Color Data Reference

Color		Input Color Data																							
		Red								Green								Blue							
		MSB		LSB						MSB		LSB						MSB		LSB					
		R7	R6	R5	R4	R3	R2	R1	R0	G7	G6	G5	G4	G3	G2	G1	G0	B7	B6	B5	B4	B3	B2	B1	B0
Basic Colors	Black	0	0	0	0	0	0	0	0	0	0	0	0	0	0	0	0	0	0	0	0	0	0	0	0
	Red(255)	1	1	1	1	1	1	1	1	0	0	0	0	0	0	0	0	0	0	0	0	0	0	0	0
	Green(255)	0	0	0	0	0	0	0	0	1	1	1	1	1	1	1	1	0	0	0	0	0	0	0	0
	Blue(255)	0	0	0	0	0	0	0	0	0	0	0	0	0	0	0	0	1	1	1	1	1	1	1	1
	Cyan	0	0	0	0	0	0	0	0	1	1	1	1	1	1	1	1	1	1	1	1	1	1	1	1
	Magenta	1	1	1	1	1	1	1	1	0	0	0	0	0	0	0	0	1	1	1	1	1	1	1	1
	Yellow	1	1	1	1	1	1	1	1	1	1	1	1	1	1	1	1	0	0	0	0	0	0	0	0
	White	1	1	1	1	1	1	1	1	1	1	1	1	1	1	1	1	1	1	1	1	1	1	1	1
Red	Red(0) Dark	0	0	0	0	0	0	0	0	0	0	0	0	0	0	0	0	0	0	0	0	0	0	0	0
	Red(1)	0	0	0	0	0	0	0	1	0	0	0	0	0	0	0	0	0	0	0	0	0	0	0	0
	Red(2)	0	0	0	0	0	0	1	0	0	0	0	0	0	0	0	0	0	0	0	0	0	0	0	0
	:	:	:	:	:	:	:	:	:	:	:	:	:	:	:	:	:	:	:	:	:	:	:	:	
	Red(253)	1	1	1	1	1	1	0	1	0	0	0	0	0	0	0	0	0	0	0	0	0	0	0	0
	Red(254)	1	1	1	1	1	1	1	0	0	0	0	0	0	0	0	0	0	0	0	0	0	0	0	0
	Red(255) Bright	1	1	1	1	1	1	1	1	0	0	0	0	0	0	0	0	0	0	0	0	0	0	0	0
Green	Green(0) Dark	0	0	0	0	0	0	0	0	0	0	0	0	0	0	0	0	0	0	0	0	0	0	0	0
	Green(1)	0	0	0	0	0	0	0	0	0	0	0	0	0	0	1	0	0	0	0	0	0	0	0	0
	Green(2)	0	0	0	0	0	0	0	0	0	0	0	0	0	1	0	0	0	0	0	0	0	0	0	0
	:	:	:	:	:	:	:	:	:	:	:	:	:	:	:	:	:	:	:	:	:	:	:	:	
	Green(253)	0	0	0	0	0	0	0	1	1	1	1	1	1	1	0	1	0	0	0	0	0	0	0	0
	Green(254)	0	0	0	0	0	0	0	1	1	1	1	1	1	1	1	0	0	0	0	0	0	0	0	0
	Green(255)Bright	0	0	0	0	0	0	0	1	1	1	1	1	1	1	1	1	0	0	0	0	0	0	0	0
Blue	Blue(0) Dark	0	0	0	0	0	0	0	0	0	0	0	0	0	0	0	0	0	0	0	0	0	0	0	0
	Blue(1)	0	0	0	0	0	0	0	0	0	0	0	0	0	0	0	0	0	0	0	0	0	0	0	1
	Blue(2)	0	0	0	0	0	0	0	0	0	0	0	0	0	0	0	0	0	0	0	0	0	0	1	0
	:	:	:	:	:	:	:	:	:	:	:	:	:	:	:	:	:	:	:	:	:	:	:	:	
	Blue(253)	0	0	0	0	0	0	0	0	0	0	0	0	0	0	0	1	1	1	1	1	1	1	0	1
	Blue(254)	0	0	0	0	0	0	0	0	0	0	0	0	0	0	0	1	1	1	1	1	1	1	1	0
	Blue(255) Bright	0	0	0	0	0	0	0	0	0	0	0	0	0	0	0	1	1	1	1	1	1	1	1	1

3-6. Power Sequences

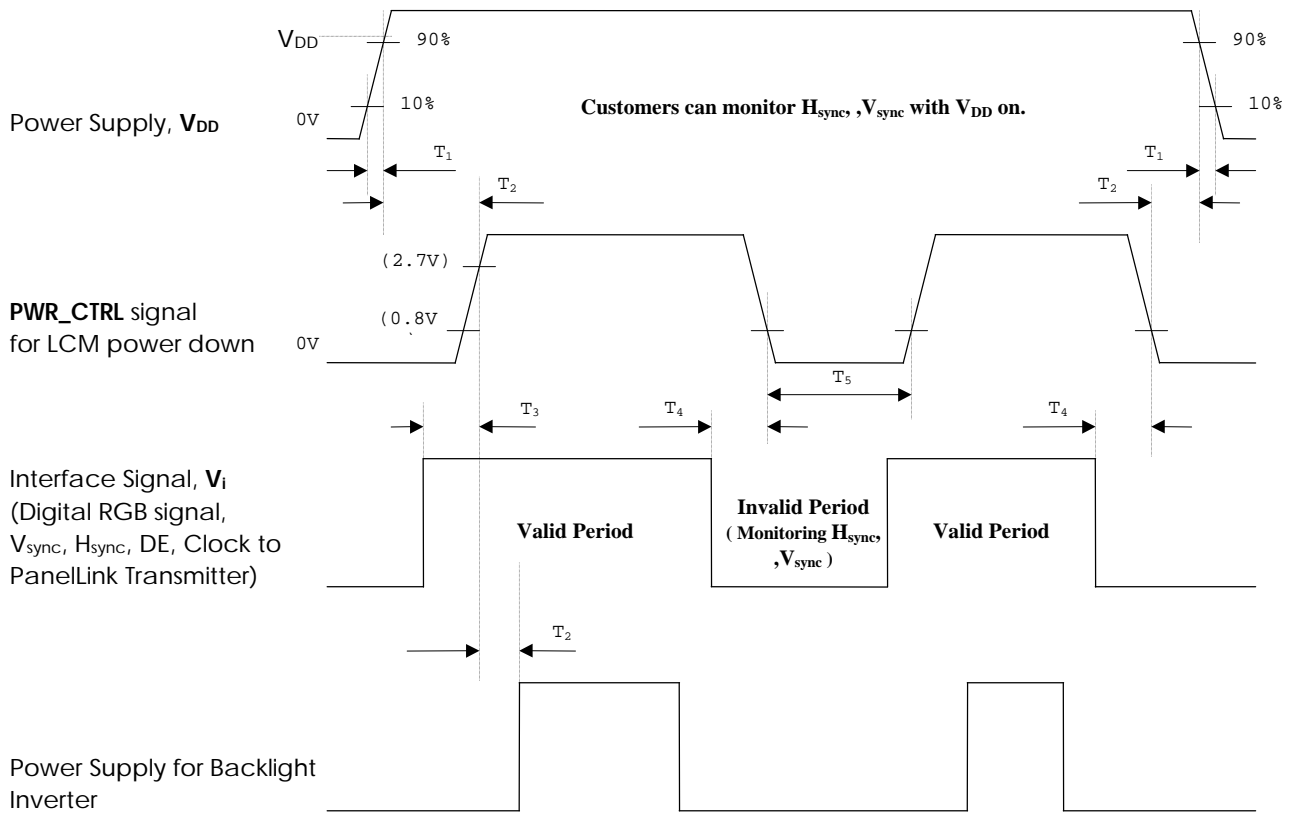

- T_1 : 10 ns ~ 20 ms (Rise time, Fall time of power supplies)
- T_2 : 100 ms (min.)
- T_3 : 100 ms (max.)
- T_4 : 100 ms (max.)
- T_5 : 500 ms (min.)

Notes: 1. Please avoid floating state of interface signal at invalid period.

2. When the interface signal is invalid or no signal, be sure to pull down the power supply, V_{DD} to 0V or to pull down the **PWR_CTRL** signal under 0.8V. Invalid signal with V_{DD} and on state of **PWR_CTRL** signal for a long period of time, causes permanent damage to LCD panel.

3. BackLight inverter power must be turn on after power supply for LCD and interface signal are valid.

4. Power supply, V_{DD} shall be start under 0.8V.

Product Specification
4.Optical Specifications

Optical characteristics are determined after the unit has been 'ON' and stable for approximately 30 minutes in a dark environment at 25 . The values specified are at an approximate distance 50cm from the LCD surface at a viewing angle of Φ and θ equal to 0° and aperture 1 degree. The test equipment is PhotoResearch Prichard SpectroRadiometer Model 1980B-SC or equivalent. The input signal voltage and timing specifications are V_{DD} of 15.0Vdc, and typical values respectively. The input current of lamp is 8mA($F_{BL} = 50\text{KHz}$) at the ground terminals.

Table 8 Optical Characteristics

 (Ta:25 , V_{DD} :15V, fv:60Hz, f_{DLK} :112.2MHz, I_{BL} :8mA, After 30minutes aging)

Parameter	Symbol	Values			Units	Notes	
		Min.	Typ.	Max.			
Contrast Ratio	CR	200	300	-		1	
Average Luminance, white	SB_{WH}	150	180	-	cd/m ²	2	
Luminance Variation	SB_V	-	-	30	%	3	
Response Time	T_r	-	-	60	msec	4	
	Rise Time T_{rR}	-	-	25			
	Decay Time T_{rD}	-	-	35			
CIE Color Coordinates	Red	x_R	0.610	0.640	0.670		
		y_R	0.310	0.340	0.370		
	Green	x_G	0.270	0.300	0.330		
		y_G	0.570	0.600	0.630		
	Blue	x_B	0.120	0.150	0.180		
		y_B	0.070	0.100	0.130		
	White	x_W	0.283	0.313	0.343		
y_W		0.299	0.329	0.359			
Viewing Angle by CR ≥ 10		x axis, right (=0°)	65	70	-	degree, °	5
		x axis, left(=180°)	65	70	-		
		y axis, up(=90°)	65	70	-		
		y axis, down (=270°)	65	70	-		
Half Luminance Angle		x axis, right (=0°)	45	-	-	degree, °	6
		x axis, left(=180°)	45	-	-		
		y axis, up(=90°)	35	-	-		
		y axis, down (=270°)	35	-	-		
Cross talk		-	-	4	%	7	
Flicker		-	-	-30	dB	8	
Relative luminance		-	-	-		9	

Product Specification

Notes 1. Contrast Ratio (CR) is defined mathematically as:

$$\frac{\text{(Surface Luminance with all white pixels)}}{\text{(Surface Luminance with all black pixels)}}$$

Contrast ratio shall be measured at the center of the display (Location 1).

2. Average luminance is the average of luminance value at location 1 to 5 with all pixels displaying white.

$$B(\text{AVE}) = \frac{B_1 + B_2 + B_3 + B_4 + B_5}{5}$$

3. The variation in surface luminance, SB_V is defined as :

$$\frac{\text{Maximum } (B_1, B_2, \dots, B_{13}) - \text{Minimum } (B_1, B_2, \dots, B_{13})}{\text{Average } (B_1, B_2, \dots, B_5)} \times 100(\%)$$

Where B1 to B13 are the luminance with all pixels displaying white at 13 locations.

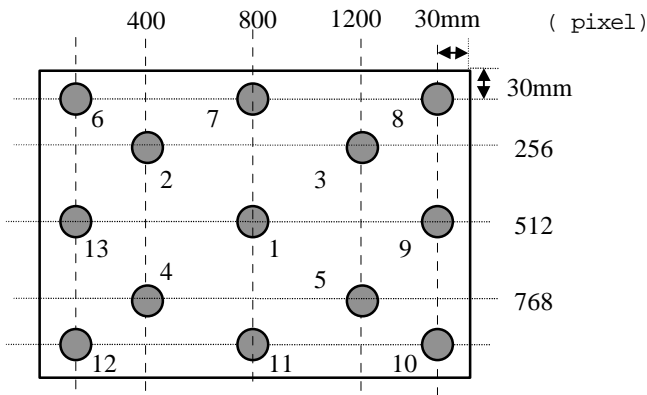

4. The response time is defined as the following figure and shall be measured by switching the input signal for "black" and "white".

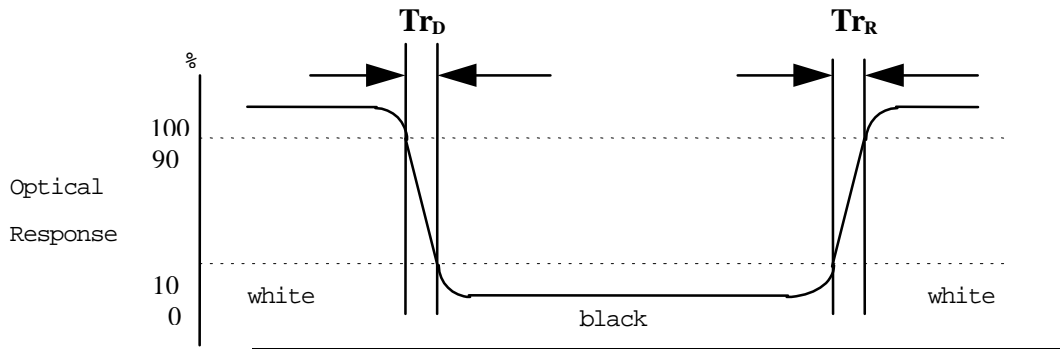

Product Specification

5. Viewing angle is the angle at which the contrast ratio is greater than 10.

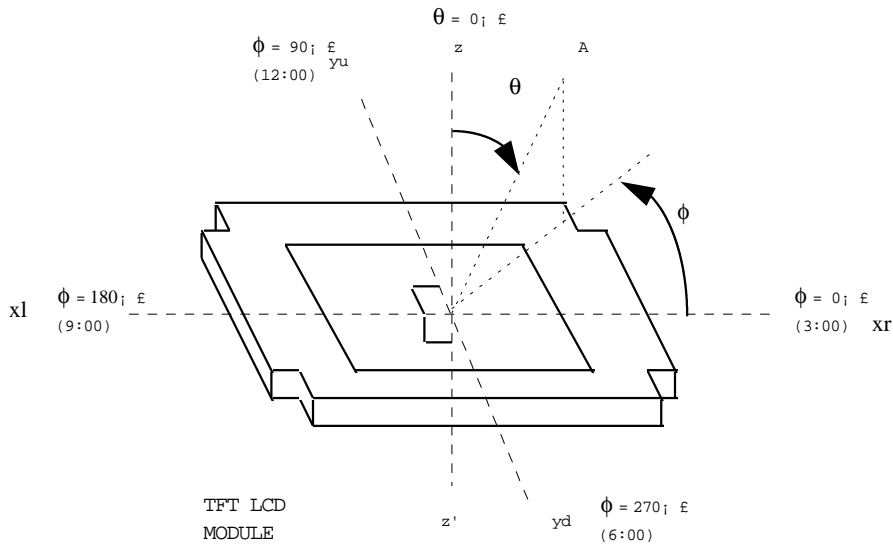

6. Half Luminance Angles

Half Luminance angles are defined as the up, down, left, and right angular boundaries at which the luminance value is 50% of the luminance value measured on-axis.

Measurements shall be done at the center of the display area (Location 1) with an all white image.

7. Cross talk shall be measured at center location.

$$\text{Crosstalk Ratio} = \frac{\text{Luminance at pattern A} - \text{Luminance at pattern B}}{\text{Luminance at pattern A}}$$

Pattern A
(Mid-gray : Gs(S)=127)



Pattern B
(Background:Gs(S)=0, Rectangular:Gs(S)=127)

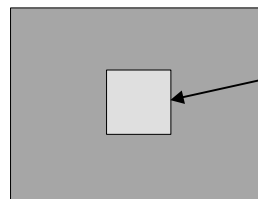

Product Specification

8. Flicker shall be measured at the center location.

Test pattern : Pixel pattern
 Background RGB gray (0, 0, 0)
 Foreground RGB gray (127,127,127)

Test equation : $20 \log \frac{\text{AC(at 30Hz)}}{\text{DC level}}$

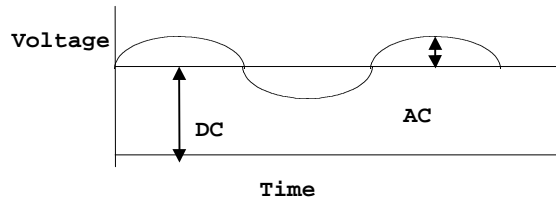

9. Relative Luminance

n	Gs(S)	Relative Luminance(%)		Remark
		min	Max	
0	0	-	0.67	
1	31	-	1.35	
2	63	2.2	4.7	
3	95	6.4	13.5	
4	127	13.6	25.8	
5	159	23.7	40.8	
6	191	41.0	60.6	
7	223	63.0	81.0	
8	255	100	100	

Product Specification

5.Mechanical Characteristics

The chart below provides general mechanical characteristics for the model LM220W1 LCD. Please refer to appendix 2 regarding the detailed mechanical drawing of the LCD module.

Table 9 Mechanical Specifications

Parameter	Value	Symbol	Notes
Outside dimension Width Height Thickness	542.0 (typ) 375.0 (typ) 35.3 (typ)	mm	
Bezel area Width Height	474.4 306.1	mm	
Active area Width Height	470.4 301.1	mm	
Weight	5000(typ) 5200(max)	gram	
Front surface of LCD	Hard coating 3H. Anti-glare treatment of the front polarizer	-	

Product Specification

6. Reliability

No	Test ITEM	Conditions
1	High temperature operating test	50 , 240 hour
2	High temperature storage test	60 , 240 hour
3	Low temperature operating test	5 , 240 hours
4	Thermal Shock Test (non-operating)	-20 /30minutes, 60 /30minutes, 50cycle
5	Altitude (non-operating)	Storage : 40,000ft
6	Vibration test (non-operating)	Waveform : Random Vibration level : 1.0 G RMS Bandwidth : 5 ~500Hz Duration : X, Y, Z, 10 min one time each direction
7	Shock test (non-operating)	Shock level : 100G Waveform: half sine wave, 2ms Direction : ±X, ±Y, ±Z one time each direction

<Result Evaluation Criteria>

There should be no changes, which might affect the practical display function when the display quality test is conducted under normal operating condition.

7. International Standards

7-1. Safety

- a) UL 1950 Third Edition, Underwriters Laboratories, Inc. Jan. 28, 1995.
Standard for Safety of Information Technology Equipment Including Electrical Business Equipment.
- b) CAN/CSA C22.2 No. 950-95 Third Edition, Canadian Standards Association, Jan. 28, 1995.
Standard for Safety of Information Technology Equipment Including Electrical Business Equipment.
- c) EN 60950 : 1992 + A1 : 1993 + A2 : 1993 + A3 : 1995 + A4 : 1997 + A11 : 1997
IEC 950 : 1991 + A1 : 1992 + A2 : 1993 + A3 : 1995 + A4 : 1996
European Committee for Electrotechnical Standardization (CENELEC)
EUROPEAN STANDARD for Safety of Information Technology Equipment Including Electrical Business Equipment.

7-2. EMC

- a) ANSI C63.4 "Methods of Measurement of Radio-Noise Emissions from Low-Voltage Electrical and Electronic Equipment in the Range of 9kHz to 40GHz." American National Standards Institute(ANSI),1992.
- b) C.I.S.P.R "Limits and Methods of Measurement of Radio Interference Characteristics of Information Technology Equipment." International Special Committee on Radio Interference
- c) EN 55022 "Limits and Methods of Measurement of Radio Interference Characteristics of Information Technology Equipment." European Committee for Electrotechnical Standardization (CENELEC),1988

Product Specification

8. Designation of Lot Mark

a) Lot Mark



A, B, C : MODEL CODE
 D : YEAR
 E : MONTH
 F, G : PANEL CODE
 H : ASSEMBLY CODE
 I, J, K, L , M : SERIAL NO.

Note : 1. YEAR

YEAR	96	97	98	99	00	01	02	03	04	05	06
Mark	6	7	8	9	0	1	2	3	4	5	6

2. MONTH

MONTH	Jan.	Feb.	Mar.	Apr.	May	Jun.	Jun.	Aug.	Sep.	Oct.	Nov.	Dec.
Mark	1	2	3	4	5	6	7	8	9	A	B	C

b) Location of Lot Mark

Serial NO. Is printed on the label. The label is attached to the backside of the LCD module.
 This is subject to change without prior notice.

9. Packing Form

a) Package quantity in one box : 3pcs

b) Box Size : 494.0 mm ×251.0 mm ×643.0 mm

Note : 1. Please, refer to appendix 3 regarding the detailed packing assembly drawing.

10.Precautions

Please pay attention to the followings when you use this TFT LCD module.

10.1 Mounting Precautions

- (1) You must mount a module using holes arranged in four corners or four sides.
- (2) You should consider the mounting structure so that uneven force (ex. twisted stress) is not applied To the module. And the case on which a module is mounted should have sufficient strength so that external force is not transmitted directly to the module.
- (3) Please attach a transparent protective plate to the surface in order to protect the polarizer. Transparent protective plate should have sufficient strength in order to resist external force.
- (4) You should adopt radiation structure to satisfy the temperature specification.
- (5) Acetic acid type and chlorine type materials for the cover case are not desirable because the former generates corrosive gas of attacking the polalizer at high temperature and the latter causes circuit break by electro-chemical reaction.
- (6) Do not touch, push or rub the exposed polarizers with glass, tweezers or anything harder than HB pencil lead. And Please do not rub with dust clothes with chemical treatment. Do not touch the surface of polarizer for bare hand or greasy cloth. (Some cosmetics are detrimental to the polarizer.)
- (7) When the surface becomes dusty, please wipe gently with absorbent cotton or other soft materials like chamois soaked with petrolium benzene. Normal-hexane is recommended for cleaning the adhesives used to attach front / rear polarizers. Do not use acetone, toluen and alcohol because they cause chemical damage to the polarizer.
- (8) Wipe off saliva or water drops as soon as possible. Their long time contact with polarizer causes deformations and color fading.
- (9) Do not open the case because inside circuits do not have sufficient strength.

10.2 Operating Precautions

- (1) The spike noise causes the mis-operation of circuits. It should be lower than following voltage :
 $V = \pm 200\text{mV}$ (Over and under shoot voltage).
- (2) Response time depends on the temperature. (In lower temperature, it becomes longer.)
- (3) Brightness depends on the temperature. (In lower temperature, it becomes lower.)
And in lower temperature, response time (required time that brightness is stable after turned on) becomes longer.
- (4) Be careful for condensation at sudden temperature change. Condensation makes damage to polarizer or electrical contacted parts. And after fading condensation, smear or spot will occur.
- (5) When fixed patterns are displayed for a long time, remnant image is likely to occur.
- (6) A module has high frequency circuit. If you need to shield the electromagnetic noise, please do in yours. When a Back-light unit is operating, it sounds. If you need to shield the noise, please do in yours.

10.3 Electrostatic Discharge Control

Since a module is composed of electronic circuits, it is not strong to electrostatic discharge. Make certain that treatment persons are connected to ground through wrist band etc . And don't touch interface pin directly.

10.4 Precautions for strong light exposure

Strong light exposure causes degradation of polarizer and color filter.

10.5 Storage

When storing modules as spares for a long time, the following precautions are necessary.

- (1) Store them in a dark place. Do not expose the module to sunlight or fluorescent light. Keep the temperature between 5 and 35 at normal humidity.
- (2) The polarizer surface should not come in contact with any other object.
It is recommended that they be stored in the container in which they were shipped.

10.6 Handling Precautions for protection film

- (1) When the protection film is peeled off, static electricity is generated between the film and polarizer. This should be peeled off slowly and carefully by people who are electrically grounded and with well ion- blown equipment or in such a condition, etc..
- (2) The protection film is attached to the polarizer with a small amount of glue. If some stress is applied to rub the protection film against the polarizer during the time you peel off the film, the glue is apt to remain on the polarizer. Please carefully peel off the protection film without rubbing it against the polarizer.
- (3) When the module with protection film attached is stored for a long time, sometimes there remains a very small amount of glue still on the polarizer after the protection film is peeled off.
- (4) You can remove the glue easily. When the glue remains on the polarizer surface or its vestige is recognized, please wipe them off with absorbent cotton waste or other soft material like chamois soaked with normal-hexane.

Product Specification
APPENDIX 1 : Required Signal Assignment for Sil150 TMD5 Receiver

Signal Name of Sil150	Pin Number of Sil150	Required Signals	
		1 pixel / clock	2 pixel / clock
DIE7 ~ DIE0	9, 10, 11, 12, 13, 14, 15, 16	Blue[7:0]	Even Blue[7:0]
DIE15 ~ DIE8	99, 100, 1, 2, 3, 4, 5, 6	Green[7:0]	Even Green[7:0]
DIE23 ~ DIE16	90, 91, 92, 93, 94, 95, 96, 97	Red[7:0]	Even Red[7:0]
DIO7 ~ DIO0	68, 69, 70, 71, 72, 73, 74, 75	N/A	Odd Blue[7:0]
DIO15 ~ DIO8	58, 59, 60, 61, 62, 63, 64, 65	N/A	Odd Green[7:0]
DIO23 ~ DIO16	48, 49, 50, 51, 52, 53, 54, 55	N/A	Odd Red[7:0]
H _{sync}	76	Horizontal Sync	Horizontal Sync
V _{sync}	77	Vertical Sync	Vertical Sync
DE	78	Data Enable	Data Enable
IDCK	80	Input Clock(112MHz)	Input Clock(56MHz)
PIXS	25	Low level	High level

- Notes : 1. Input data shall be followed by D₀(R₀G₀B₀), D₁(R₁G₁B₁), D₂(R₂G₂B₂), D₃(R₃G₃B₃), D₄(R₄G₄B₄).
2. Refer to Sil150 Data Sheet or application notes for detail descriptions.

Product Specification

APPENDIX 2 : Outline Drawings

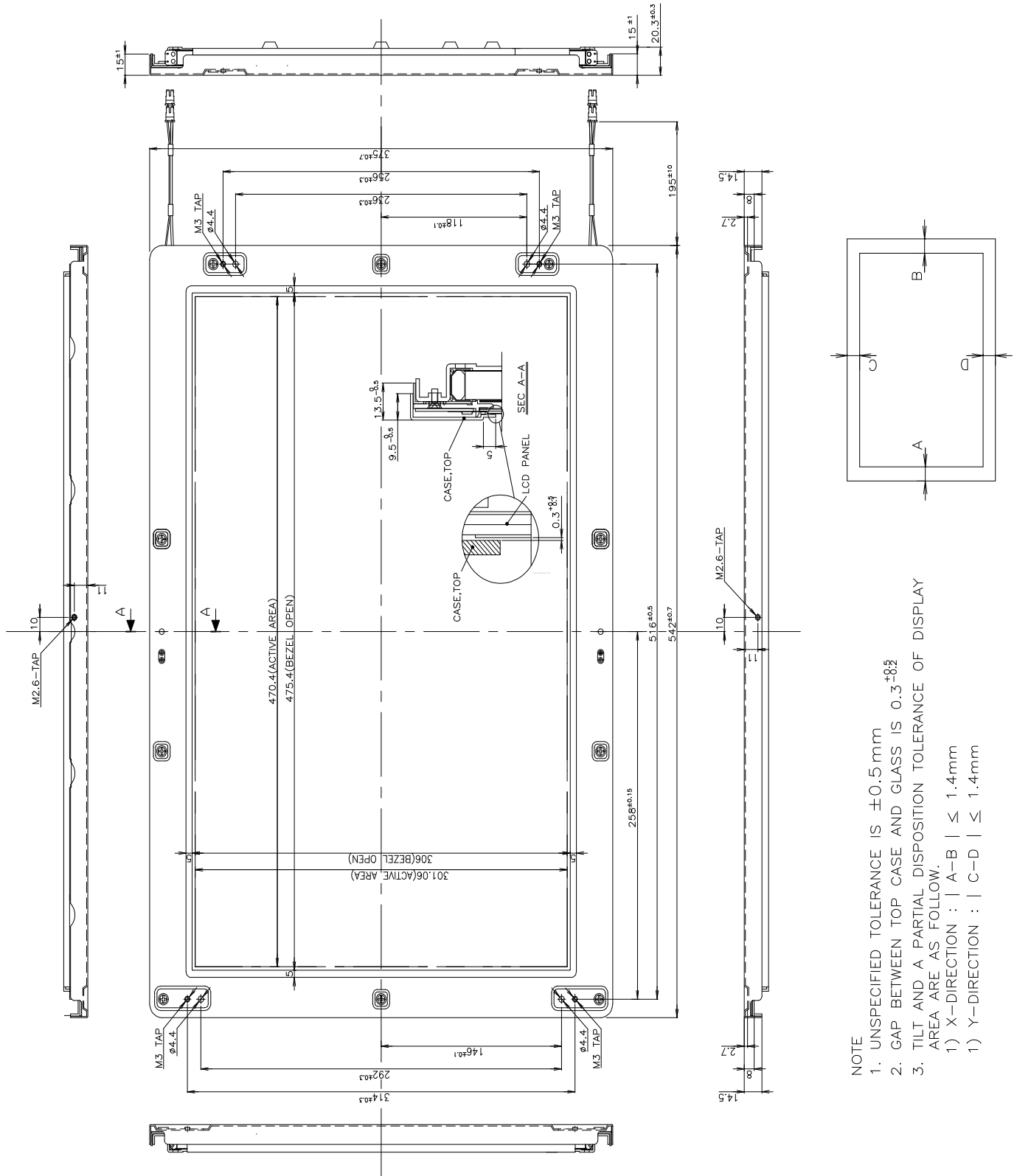

- NOTE
1. UNSPECIFIED TOLERANCE IS ± 0.5 mm
 2. GAP BETWEEN TOP CASE AND GLASS IS 0.3 ± 0.02
 3. TILT AND A PARTIAL DISPOSITION TOLERANCE OF DISPLAY AREA ARE AS FOLLOW.
 - 1) X-DIRECTION : | A-B | \leq 1.4mm
 - 1) Y-DIRECTION : | C-D | \leq 1.4mm

Product Specification

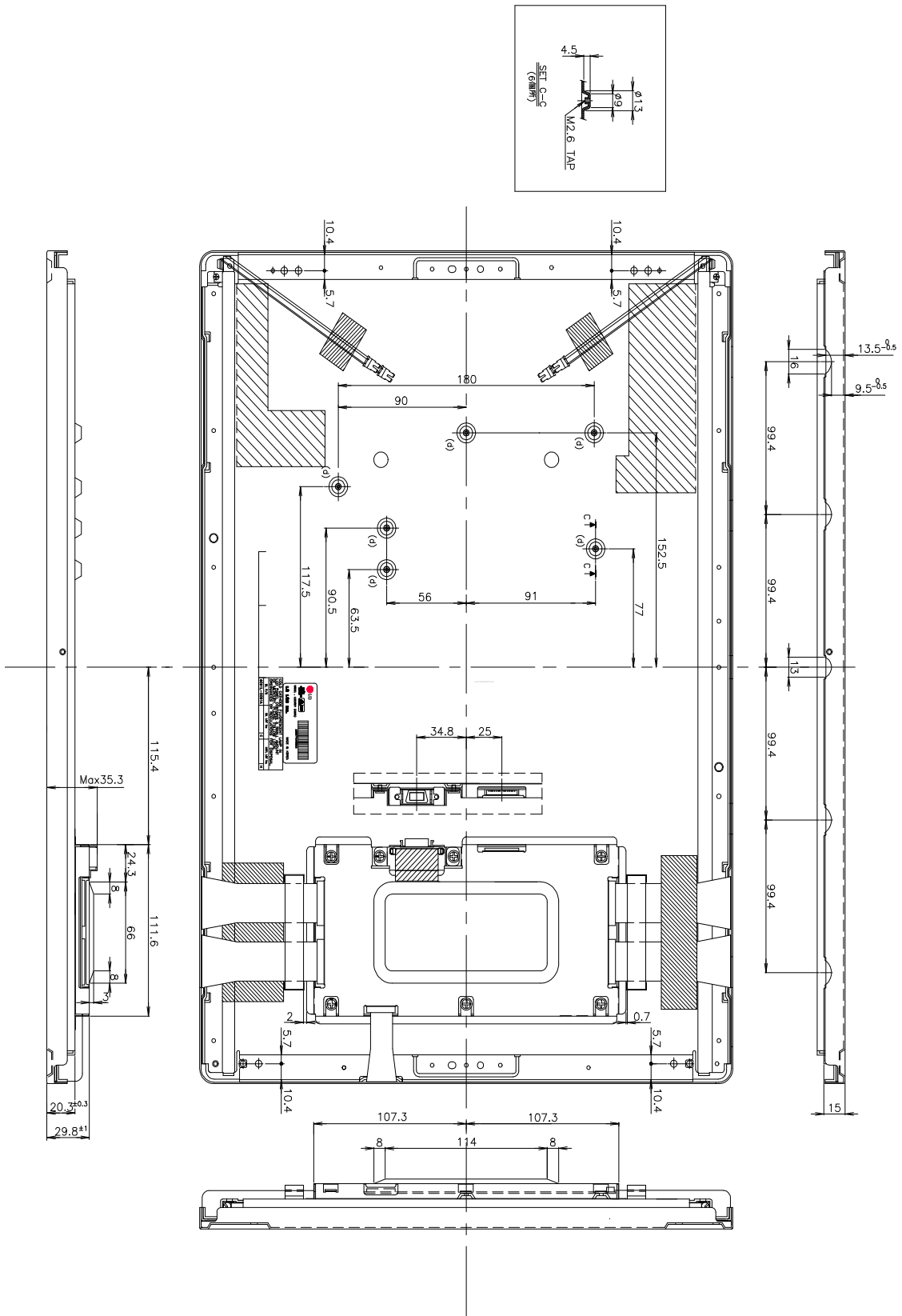

Product Specification

APPENDIX 3 : Packing Assembly Drawings

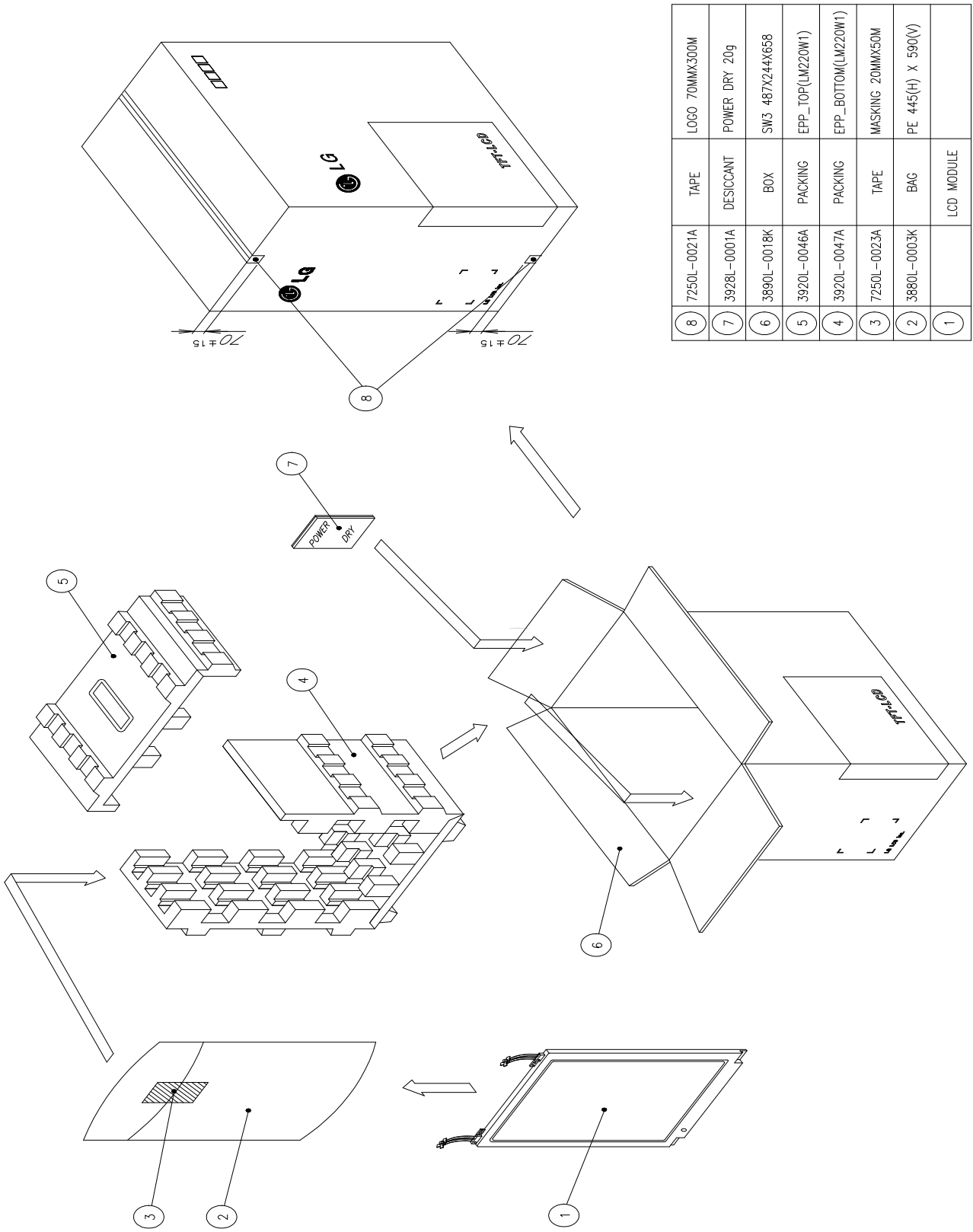

8	7250L-0021A	TAPE	LOGO 70MMX300M
7	3928L-0001A	DESICCANT	POWER DRY 20g
6	3990L-0018K	BOX	SW3 487X244X658
5	3920L-0046A	PACKING	EPP_TOP(LM220W1)
4	3920L-0047A	PACKING	EPP_BOTTOM(LM220W1)
3	7250L-0023A	TAPE	MASKING 20MMX50M
2	3880L-0003K	BAG	PE 445(H) X 590(V)
1		LCD MODULE	

Product Specification

NO	PART NO	DESCRIPTION
⑥	4770L-C002A	BAND, CLIP
⑤	4770L-P001A	BAND, PACKING
④	3000L-0002F	ANGLE, COVER
③	3858L-0002A	SHEET
②	3930L-0003A	PALLET
①	3921L-0027A	PACKING ASSY

