

Product Specification

SPECIFICATION FOR APPROVAL

Preliminary Specification
 Final Specification

Title	22" WSXGA+ TFT LCD
-------	---------------------------

BUYER	General
MODEL	

SUPPLIER	LG.Philips LCD CO., Ltd.
*MODEL	LM220WE1
SUFFIX	TLB2

*When you obtain standard approval, please use the above model name without suffix

SIGNATURE	DATE
/	_____
/	_____
/	_____

APPROVED BY	DATE
K.G. Park / G.Manager	_____
REVIEWED BY	
S.J. So / Manager [C]	_____
S.Y. An / Manager [M]	_____
H.S. Lee / Manager [P]	_____
PREPARED BY	
H.S. Kim / Engineer	_____

Please return 1 copy for your confirmation
With your signature and comments.

**Product Engineering Dept.
LG. Philips LCD Co., Ltd**

Product Specification

Contents

No	ITEM	Page
	COVER	1
	CONTENTS	2
	RECORD OF REVISIONS	3
1	GENERAL DESCRIPTION	4
2	ABSOLUTE MAXIMUM RATINGS	5
3	ELECTRICAL SPECIFICATIONS	6
3-1	ELECTRICAL CHARACTREISTICS	6
3-2	INTERFACE CONNECTIONS	9
3-3	SIGNAL TIMING SPECIFICATIONS	15
3-4	SIGNAL TIMING WAVEFORMS	16
3-5	COLOR INPUT DATA REFERNECE	17
3-6	V _{LCD} POWER DIP CONDITION	18
3-7	POWER SEQUENCE	19
4	OPTICAL SFECIFICATIONS	20
5	MECHANICAL CHARACTERISTICS	24
6	RELIABILITY	27
7	INTERNATIONAL STANDARDS	28
7-1	SAFETY	28
7-2	EMC	28
8	PACKING	29
8-1	DESIGNATION OF LOT MARK	29
8-2	PACKING FORM	29
9	PRECAUTIONS	30

Product Specification

1. General Description

LM220WE1 is a Color Active Matrix Liquid Crystal Display with an integral Cold Cathode Fluorescent Lamp(CCFL) backlight system. The matrix employs a-Si Thin Film Transistor as the active element. It is a transmissive type display operating in the normally White mode. It has a 22 inch diagonally measured active display area with WSXGA+ resolution (1050 vertical by 1680 horizontal pixel array)

Each pixel is divided into Red, Green and Blue sub-pixels or dots which are arranged in vertical stripes. Gray scale or the brightness of the sub-pixel color is determined with a 8-bit gray scale signal for each dot, thus, presenting a palette of more than 16,7M colors with A-FRC(Advanced Frame Rate Control). It has been designed to apply the 8Bit 2 port LVDS interface.

It is intended to support displays where high brightness, super wide viewing angle, high color saturation, and high color are important.

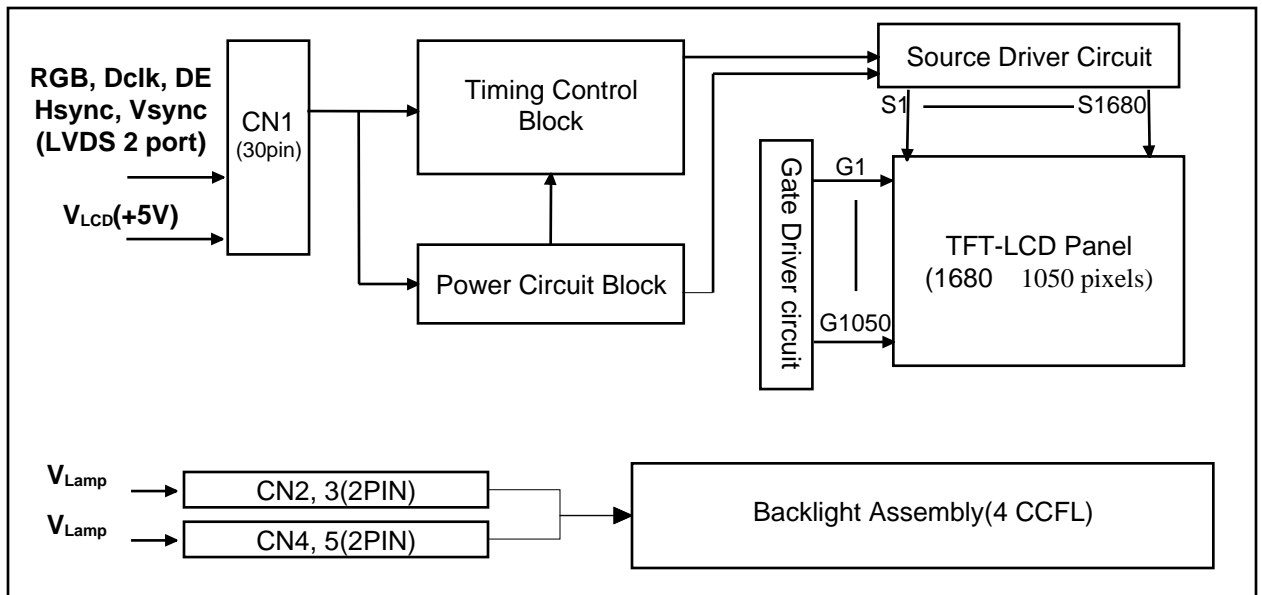

General Features

Active Screen Size	21.995 inches(558.673mm) diagonal (Aspect ratio 16:10)
Outline Dimension	493.7(H) x 320.1 (V) x 16.5(D) mm (Typ.)
Pixel Pitch	0.282mm x 0.282mm
Pixel Format	1680 horiz. By 1050 vert. Pixels RGB strip arrangement
Color Depth	16,7 M colors
Luminance, White	300 cd/m ² (Center 1 point, Typ.)
Power Consumption	Total 29.25 Watt(Typ.) (4.370 Watt@V _{LCD} , 24.88 Watt@300cd/[LAMP=7.5mA])
Weight	2800 g (Typ.)
Display Operating Mode	Transmissive mode, Normally White
Surface Treatment	Hard coating(2H) & Glare treatment of the front polarizer

Product Specification

2. Absolute Maximum Ratings

The following are maximum values which, if exceeded, may cause faulty operation or damage to the unit.

Table 1. ABSOLUTE MAXIMUM RATINGS

Parameter	Symbol	Values		Units	Notes
		Min	Max		
Power Input Voltage	V _{LCD}	-0.3	+5.5	V _{DC}	at 25 ± 2 °C
Operating Temperature	T _{OP}	0	50	°C	1
Storage Temperature	T _{ST}	-20	60	°C	1
Operating Ambient Humidity	H _{OP}	10	90	%RH	1
Storage Humidity	H _{ST}	10	90	%RH	1

Note : 1. Temperature and relative humidity range are shown in the figure below.
Wet bulb temperature should be 39 °C Max, and no condensation of water.

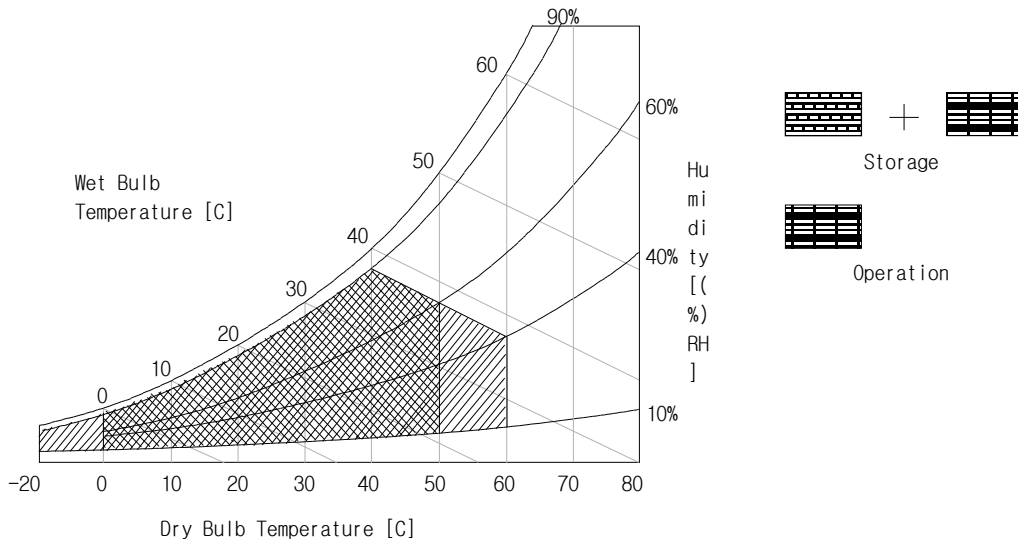

Product Specification

3. Electrical Specifications

3-1. Electrical Characteristics

It requires two power inputs. One is employed to power the LCD electronics and to drive the TFT array and liquid crystal. The second input power for the CCFL, is typically generated by an inverter. The inverter is an external unit to the LCDs.

Table 2_1. ELECTRICAL CHARACTERISTICS

Parameter	Symbol	Values			Unit	Notes
		Min	Typ	Max		
MODULE :						
Power Supply Input Voltage	V _{LCD}	4.5	5.0	5.5	Vdc	
Power Supply Input Current	I _{LCD}	-	874	1005	mA	1
		-	1094	1422	mA	2
Power Consumption	P _{LCD}	-	4.370	5.025	Watt	1
Rush current	I _{RUSH}	-	-	3	A	3

Note :

1. The specified current and power consumption are under the $V_{CD}=5.0V$, $25^{\circ}C$, $f_v=60Hz$ condition whereas mosaic pattern(8 x 6) is displayed and f_v is the frame frequency.
2. The current is specified at the maximum current pattern.
3. The duration of rush current is about 2ms and rising time of power Input is 500us 20%.(min.).

White : 255Gray
Black : 0Gray

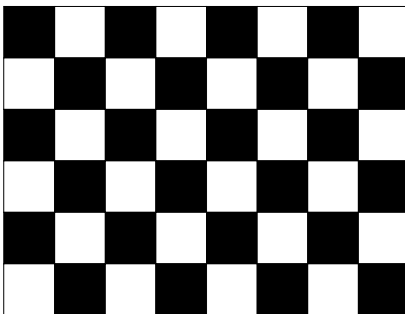

Mosaic Pattern(8 x 6)

Maximum current pattern

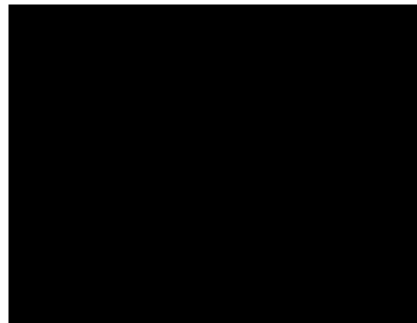

Black Pattern

Product Specification

Table 2_2. ELECTRICAL CHARACTERISTICS

Parameter	Symbol	Values			Unit	Notes
		Min	Typ	Max		
LAMP :						
Operating Voltage	V _{BL}	810	830	1000	V _{RMS}	1, 2
Operating Current	I _{BL}	3.0	7.5	8.0	mA _{RMS}	1
Established Starting Voltage	V _s					1, 3
	at 25 °C			1250	V _{RMS}	
	at 0 °C			1550	V _{RMS}	
Operating Frequency	f _{BL}	40	60	80	kHz	4
Discharge Stabilization Time	T _s			3	Min	1, 5
Power Consumption	P _{BL}		24.9	27.4	W	6
Life Time		50,000			Hrs	1, 7

The performance of the Lamp in LCM, for example life time or brightness, is extremely influenced by the characteristics of the DC-AC inverter. So all the parameters of an inverter should be carefully designed so as not to produce too much leakage current from high-voltage output of the

inverter.

When you design or order the inverter, please make sure unwanted lighting caused by the mismatch of the lamp and the inverter (no lighting, flicker, etc) never occurs. When you confirm it, the LCD-

Assembly should be operated in the same condition as installed in you instrument.

※ Do not attach a conducting tape to lamp connecting wire.

If the lamp wire attach to a conducting tape, TFT-LCD Module has a low luminance and the inverter has abnormal action. Because leakage current is occurred between lamp wire and conducting tape.

1. Specified values are for a single lamp.

2. Operating voltage is measured at 25 °C. The variance of the voltage is 10%.

3. The voltage above V_s should be applied to the lamps for more than 1 second for start-up.

(Inverter open voltage must be more than lamp starting voltage.)

Otherwise, the lamps may not be turned on. The used lamp current is the lamp typical

current.

4. Lamp frequency may produce interface with horizontal synchronous frequency and as a result this may

cause beat on the display. Therefore lamp frequency shall be as away possible from the horizontal synchronous frequency and from its harmonics in order to prevent interference.

5. Let's define the brightness of the lamp after being lighted for 5 minutes as 100%.

T_s is the time required for the brightness of the center of the lamp to be not less than 95%.

6. The lamp power consumption shown above does not include loss of external inverter.

The used lamp current is the lamp typical current. (P_{BL} = V_{BL} × I_{BL} × N_{Lamp})

7. The life is determined as the time at which brightness of the lamp is 50% compared to that of initial

value at the typical lamp current on condition of continuous operating at 25 °C.

Product Specification

- and
8. The output of the inverter must have symmetrical(negative and positive) voltage waveform and symmetrical current waveform (Unsymmetrical ratio is less than 10%). Please do not use the inverter which has unsymmetrical voltage and unsymmetrical current and spike wave. Requirements for a system inverter design, which is intended to have a better display performance, a better power efficiency and a more reliable lamp, are following.
It shall help increase the lamp lifetime and reduce leakage current.
- a. The asymmetry rate of the inverter waveform should be less than 10%.
 - b. The distortion rate of the waveform should be within $2 \pm 10\%$.
- * Inverter output waveform had better be more similar to ideal sine wave.

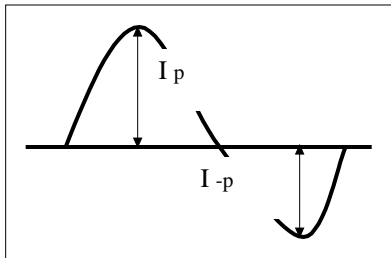

* Asymmetry rate:

$$| I_p - I_{-p} | / I_{rms} \times 100\%$$

* Distortion rate

$$I_p \text{ (or } I_{-p}) / I_{rms}$$

9. The inverter which is combined with this LCM, is highly recommended to connect coupling(ballast) condenser at the high voltage output side. When you use the inverter which has not coupling(ballast) condenser, it may cause abnormal lamp lighting because of biased mercury as time goes.
10. In case of edgy type back light with over 4 parallel lamps, input current and voltage wave form should be synchronized

Product Specification

3-2. Interface Connections

Interface chip must be used LVDS, part No. SN75LVDS83 (Tx, Texas Instrument) or compatible. This LCD employs a interface connection, a 30 pin connector is used for the module electronics interface. Four 2pin connectors are used for the integral backlight system. The electronics interface connector is a model MDF76LBRW-30S-1H manufactured by HIROSE or FI-XB30SRL-HF11 manufactured by JAE. The pin configuration for the connector is shown in the table 3 and the signal mapping with LVDS transmitter is shown in the table 4.

Table 3. MODULE CONNECTOR(CN1) PIN CONFIGURATION

Pin No	Symbol	Description
1	RxO0-	Minus signal of odd channel 0 (LVDS)
2	RxO0+	Plus signal of odd channel 0 (LVDS)
3	RxO1-	Minus signal of odd channel 1 (LVDS)
4	RxO1+	Plus signal of odd channel 1 (LVDS)
5	RxO2-	Minus signal of odd channel 2 (LVDS)
6	RxO2+	Plus signal of odd channel 2 (LVDS)
7	GND	Ground
8	RxOC-	Minus signal of odd clock channel (LVDS)
9	RxOC+	Plus signal of odd clock channel (LVDS)
10	RxO3-	Minus signal of odd channel 3 (LVDS)
11	RxO3+	Plus signal of odd channel 3 (LVDS)
12	RxE0-	Minus signal of even channel 0 (LVDS)
13	RxE0+	Plus signal of even channel 0 (LVDS)
14	GND	Ground
15	RxE1-	Minus signal of even channel 1 (LVDS)
16	RxE1+	Plus signal of even channel 1 (LVDS)
17	GND	Ground
18	RxE2-	Minus signal of even channel 2 (LVDS)
19	RxE2+	Plus signal of even channel 2 (LVDS)
20	RxEC-	Minus signal of even clock channel (LVDS)
21	RxEC+	Plus signal of even clock channel (LVDS)
22	RxE3-	Minus signal of even channel 3 (LVDS)
23	RxE3+	Plus signal of even channel 3 (LVDS)
24	GND	Ground
25	NC	No Connection
26	NC	No Connection
27	PWM_OUT	PWM_OUT signal for control burst frequency of Inverter
28	VCC	Power Supply +5.0V
29	VCC	Power Supply +5.0V
30	VCC	Power Supply +5.0V

First Pixel data

Second Pixel data

Product Specification

User Connector Diagram

MDF76LBRW-30S-1H(Hirose)
FI-XB30SRL-HF11 (JAE)

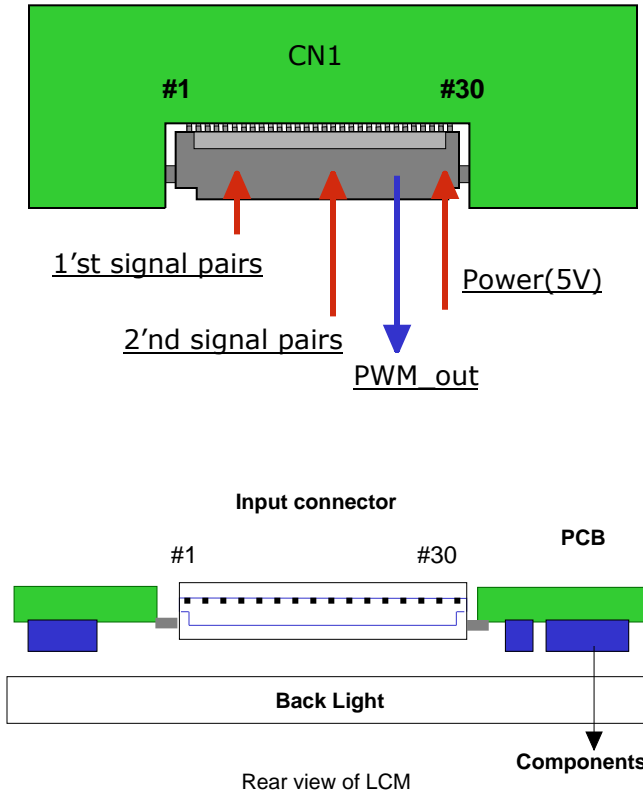

- Notes:
1. All GND(ground) pins should be connected together and should also be connected to the LCD's metal frame.
 2. All V_{cc}(power input) pins should be connected together.
 3. All NC pins should be separated from other signal or power.
 4. PWM_OUT signal controls the burst frequency of a inverter.
This signal is synchronized with vertical frequency,
it's frequency is 3 times of vertical frequency, and its duty ratio is 50%.
If you don't use this pin, it is no connection.

Product Specification

Table 4. REQUIRED SIGNAL ASSIGNMENT FOR Flat Link (TI:SN75LVDS83) Transmitter

Pin #	Pin Name	Require Signal	Pin #	Pin Name	Require Signal
1	Vcc	Power Supply for TTL Input	29	GND	Ground pin for TTL
2	D5	TTL Input (R7)	30	D26	TTL Input (DE)
3	D6	TTL Input (R5)	31	T _x CLKIN	TTL Level clock Input
4	D7	TTL Input (G0)	32	PWR DWN	Power Down Input
5	GND	Ground pin for TTL	33	PLL GND	Ground pin for PLL
6	D8	TTL Input (G1)	34	PLL Vcc	Power Supply for PLL
7	D9	TTL Input (G2)	35	PLL GND	Ground pin for PLL
8	D10	TTL Input (G6)	36	LVDS GND	Ground pin for LVDS
9	Vcc	Power Supply for TTL Input	37	TxOUT3 +	Positive LVDS differential data output 3
10	D11	TTL Input (G7)	38	TxOUT3 -	Negative LVDS differential data output 3
11	D12	TTL Input (G3)	39	T _x CLKOUT +	Positive LVDS differential clock output
12	D13	TTL Input (G4)	40	T _x CLKOUT -	Negative LVDS differential clock output
13	GND	Ground pin for TTL	41	T _x OUT2 +	Positive LVDS differential data output 2
14	D14	TTL Input (G5)	42	T _x OUT2 -	Negative LVDS differential data output 2
15	D15	TTL Input (B0)	43	LVDS GND	Ground pin for LVDS
16	D16	TTL Input (B6)	44	LVDS Vcc	Power Supply for LVDS
17	Vcc	Power Supply for TTL Input	45	T _x OUT1 +	Positive LVDS differential data output 1
18	D17	TTL Input (B7)	46	T _x OUT1 -	Negative LVDS differential data output 1
19	D18	TTL Input (B1)	47	T _x OUT0 +	Positive LVDS differential data output 0
20	D19	TTL Input (B2)	48	T _x OUT0 -	Negative LVDS differential data output 0
21	GND	Ground pin for TTL Input	49	LVDS GND	Ground pin for LVDS
22	D20	TTL Input (B3)	50	D27	TTL Input (R6)
23	D21	TTL Input (B4)	51	D0	TTL Input (R0)
24	D22	TTL Input (B5)	52	D1	TTL Input (R1)
25	D23	TTL Input (RSVD)	53	GND	Ground pin for TTL
26	Vcc	Power Supply for TTL Input	54	D2	TTL Input (R2)
27	D24	TTL Input (HSYNC)	55	D3	TTL Input (R3)
28	D25	TTL Input (VSYNC)	56	D4	TTL Input (R4)

Notes : 1. Refer to LVDS Transmitter Data Sheet for detail descriptions.
 2. 7 means MSB and 0 means LSB at R,G,B pixel data

Product Specification

LVDS Input characteristics

1. DC Specification

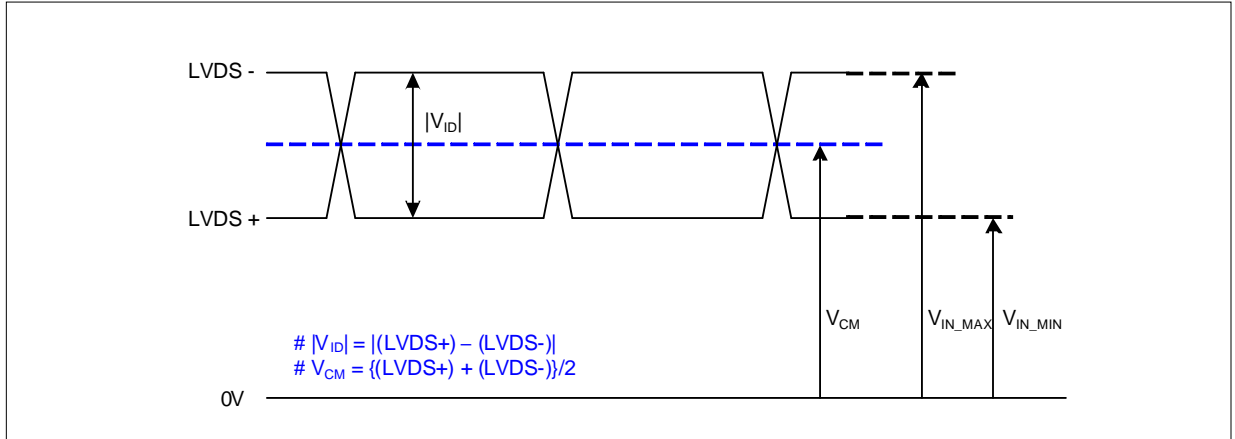

Description	Symbol	Min	Max	Unit	Notes
LVDS Differential Voltage	$ V_{ID} $	100	600	mV	-
LVDS Common mode Voltage	V_{CM}	0.6	1.8	V	-
LVDS Input Voltage Range	V_{IN}	0.3	2.1	V	-

2. AC Specification

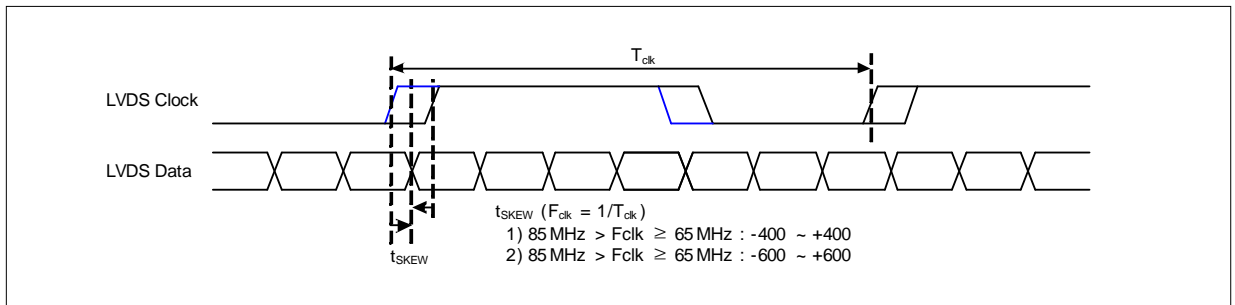

Description	Symbol	Min	Max	Unit	Notes
LVDS Clock to Data Skew Margin	t_{SKEW}	- 400	+ 400	ps	85MHz > Fclk ≥ 65MHz
	t_{SKEW}	- 600	+ 600	ps	65MHz > Fclk ≥ 25MHz
LVDS Clock to Clock Skew Margin (Even to Odd)	t_{SKEW_EO}	- 1/7	+ 1/7	T_{clk}	-
Maximum deviation of input clock frequency during SSC	F_{DEV}	-	± 3	%	-
Maximum modulation frequency of input clock during SSC	F_{MOD}	-	200	KHz	-

Product Specification

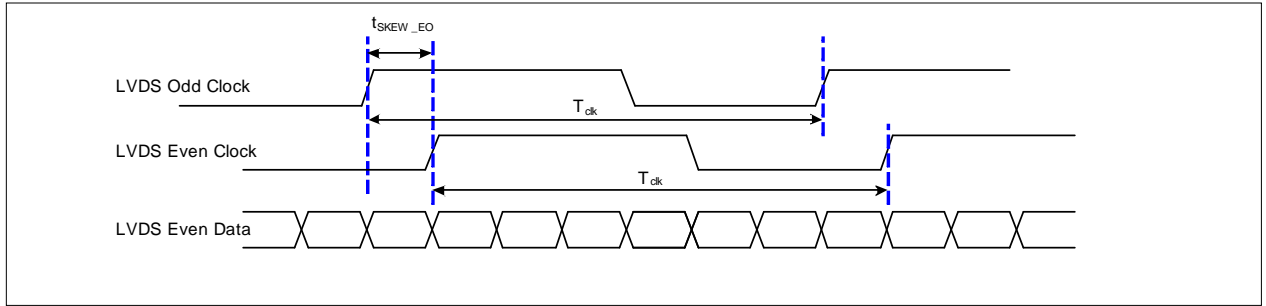

< Clock skew margin between channel >

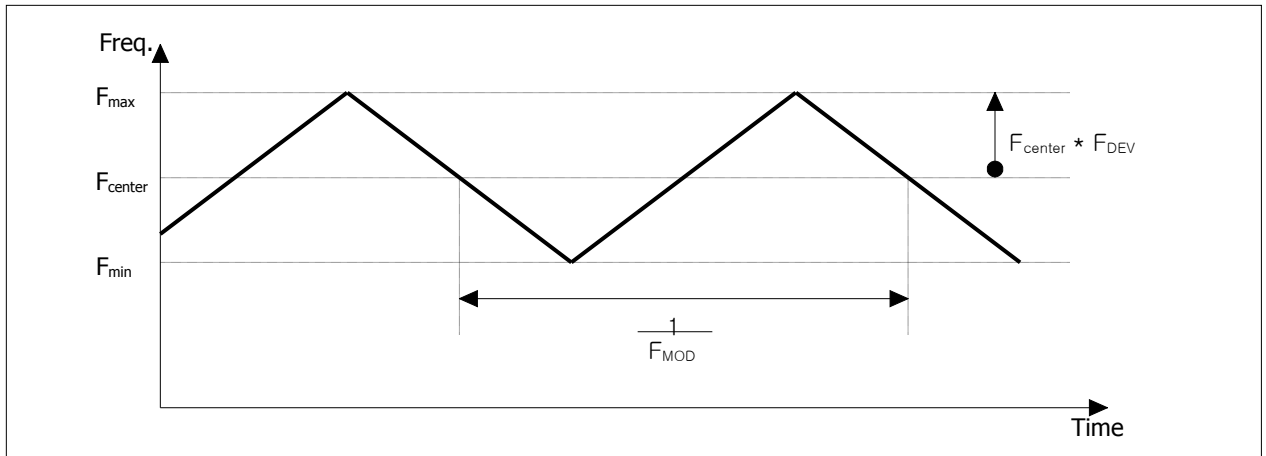

< Spread Spectrum >

3. Data Format

1) LVDS 2 Port

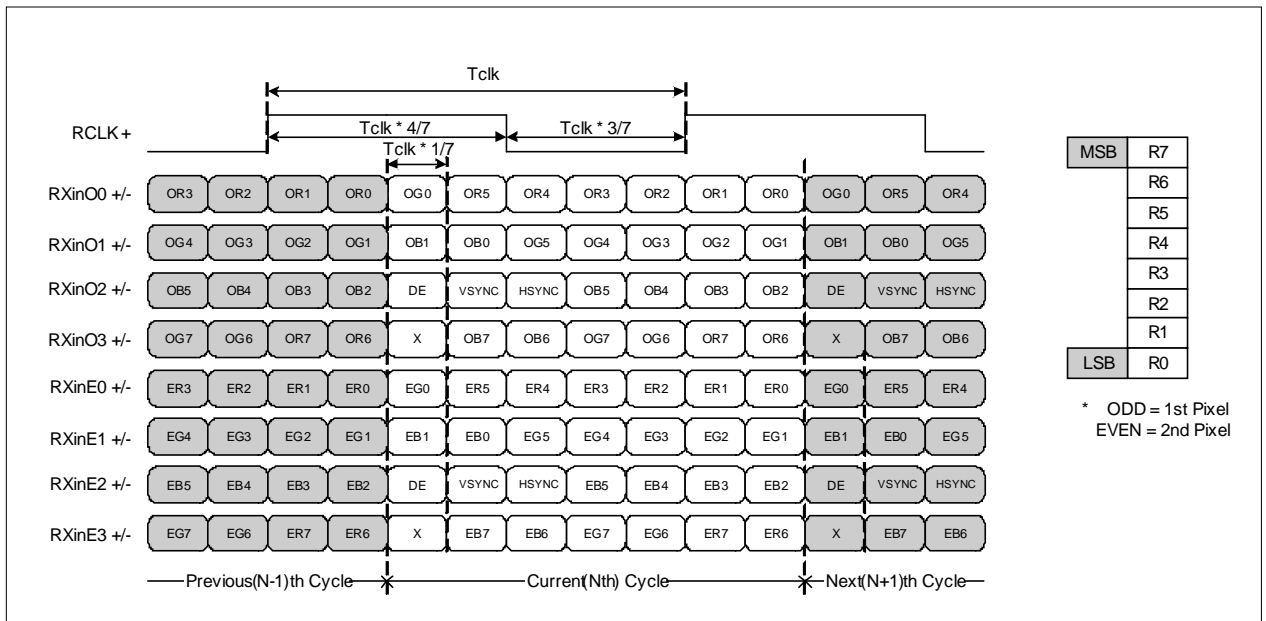

< LVDS Data Format >

MSB	R7
	R6
	R5
	R4
	R3
	R2
	R1
LSB	R0

* ODD = 1st Pixel
EVEN = 2nd Pixel

Product Specification

The backlight interface connector is a model 35001HS-02LD (YE0NH0).
The mating connector part number is 35001WR-02L or equivalent.
The pin configuration for the connector is shown in the table 5.

Table 5. Backlight connector pin configuration

Pin	Symbol	Description	Notes
1	HV	High Voltage for lamp	1
2	LV	Low Voltage for lamp	1,2

- Note :
1. The high voltage power terminal is colored Pink, Sky blue.
 2. The low voltage pin color is Black, Blue.
 3. The backlight ground should be common with LCD metal frame.

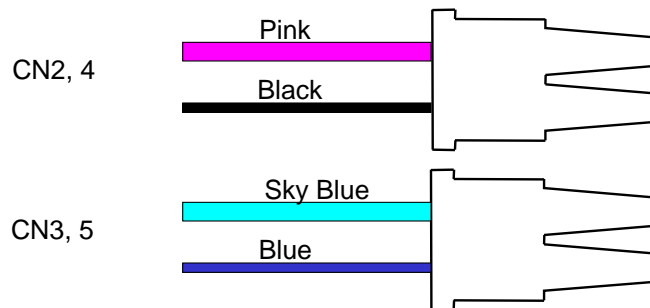

[Figure 1.] Backlight connector view

Product Specification

3-3. Signal Timing Specifications

This is the signal timing required at the input of the User connector. All of the interface signal timing should be satisfied with the following specifications for it's proper operation.

Table 6. Timing Table

ITEM	Symbol		Min	Typ	Max	Unit	Note
DCLK	Period	tCLK	12.19	16.8	21.1	ns	Pixel frequency : Typ.119MHz
	Frequency	-	47.375	59.5	82	MHz	
Hsync	Period	tHP	880	920	1200	tCLK	
	Width	tWH	8	16	64	tCLK	
Vsync	Period	tVP	1060	1080	1300	tHP	
	Frequency	fV	50	60	75	Hz	
	Width	tWV	3	6	205	tHP	
DE (Data Enable)	Horizontal Valid	tHV	840	840	840	tCLK	
	Horizontal Back Porch	tHBP	16	40	200		
	Horizontal Front Porch	tHFP	16	24	96		
			-	-	-		
	Vertical Valid	tVv	1050	1050	1050	tHP	
	Vertical Back Porch	tVBP	5	21	39		
	Vertical Front Porch	tVFP	2	3	6		
			-	-	-		
	DE Setup Time	tSI	4	-	-	ns	For D _{CLK}
	DE Hold Time	tHI	4	-	-		
Data	Data Setup Time	tSD	4	-	-	ns	For D _{CLK}
	Data Hold Time	tHD	4	-	-		

Notes : 1. DE Only mode operation

2. $t_{HFP} + t_{WH} + t_{HBP} < (1/2) t_{HV}$

3. $t_{VFP} + t_{WV} + t_{VBP} < t_{H_max} / t_{v_min}$

4. tHFP, tWH and tHBP should be any times of a character number (8).

5. No variation of the total number of Hsync and DE in a frame is required for normal operation.

6. No variation of the total number of clock in a Hsync period for t_{BP} is required for normal operation.

Product Specification

3-4. Signal Timing Waveforms

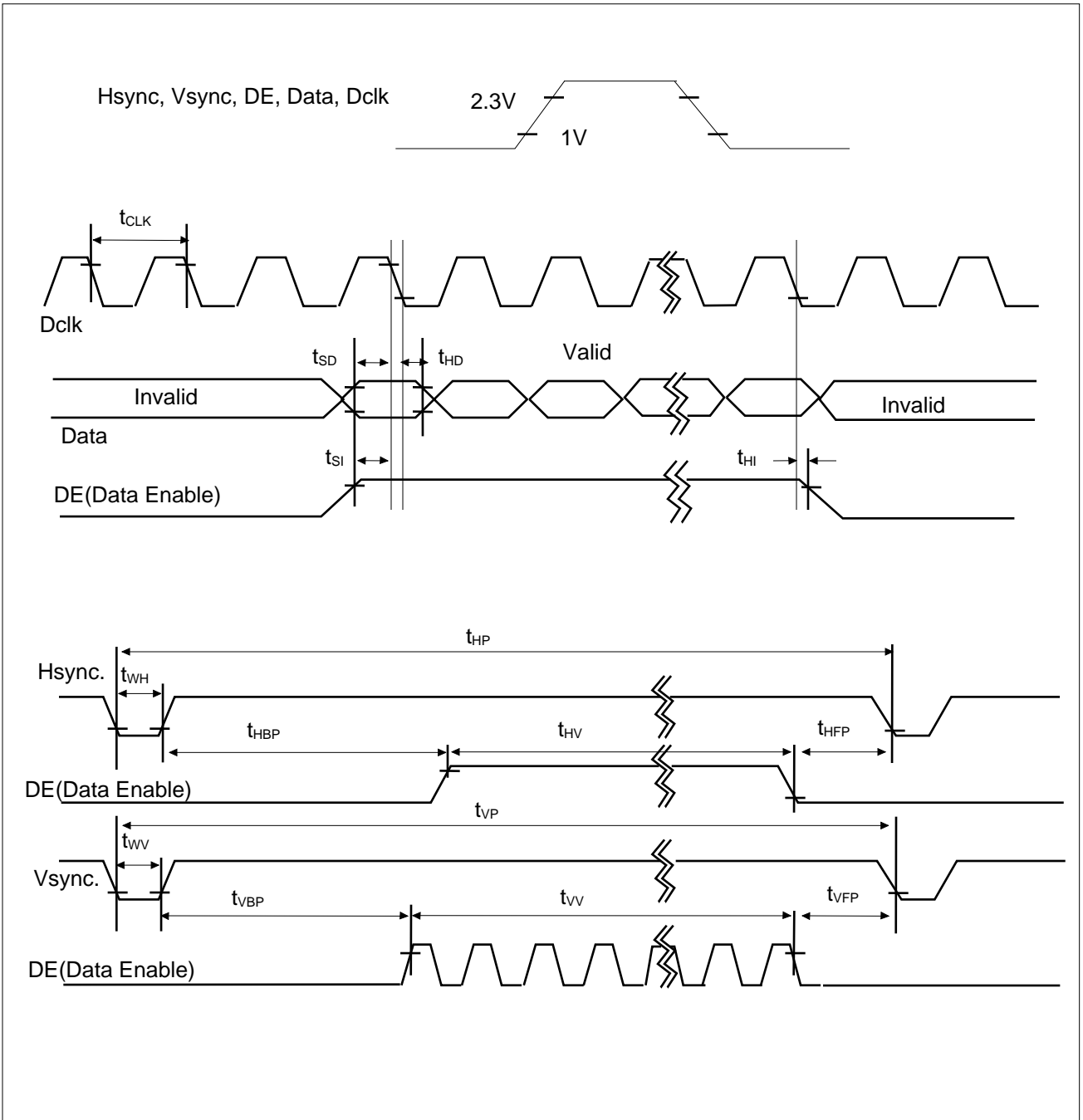

[Figure 2.] Signal timing waveforms

Product Specification

3-5. Color Input Data Reference

The brightness of each primary color(red,green and blue) is based on the 8-bit gray scale data input for the color ; the higher the binary input, the brighter the color. The table below provides a reference for color versus data input.

Table 7. Color data reference

Color		Input color data																							
		Red								Green								Blue							
		MSB				LSB				MSB				LSB				MSB				LSB			
		R7	R6	R5	R4	R3	R2	R1	R0	G7	G6	G5	G4	G3	G2	G1	G0	B7	B6	B5	B4	B3	B2	B1	B0
Basic colors	Black	0	0	0	0	0	0	0	0	0	0	0	0	0	0	0	0	0	0	0	0	0	0	0	0
	Red(255)	1	1	1	1	1	1	1	1	0	0	0	0	0	0	0	0	0	0	0	0	0	0	0	0
	Green(255)	0	0	0	0	0	0	0	0	1	1	1	1	1	1	1	1	0	0	0	0	0	0	0	0
	Blue(255)	0	0	0	0	0	0	0	0	0	0	0	0	0	0	0	0	1	1	1	1	1	1	1	1
	Cyan	0	0	0	0	0	0	0	0	1	1	1	1	1	1	1	1	1	1	1	1	1	1	1	1
	Magenta	1	1	1	1	1	1	1	1	0	0	0	0	0	0	0	0	1	1	1	1	1	1	1	1
	Yellow	1	1	1	1	1	1	1	1	1	1	1	1	1	1	1	1	0	0	0	0	0	0	0	0
	White	1	1	1	1	1	1	1	1	1	1	1	1	1	1	1	1	1	1	1	1	1	1	1	1
Red	Red(000) dark	0	0	0	0	0	0	0	0	0	0	0	0	0	0	0	0	0	0	0	0	0	0	0	0
	Red(001)	0	0	0	0	0	0	0	1	0	0	0	0	0	0	0	0	0	0	0	0	0	0	0	0
	Red(002)	0	0	0	0	0	0	1	0	0	0	0	0	0	0	0	0	0	0	0	0	0	0	0	0
	:	:	:	:	:	:	:	:	:	:	:	:	:	:	:	:	:	:	:	:	:	:	:	:	:
	Red(253)	1	1	1	1	1	1	0	1	0	0	0	0	0	0	0	0	0	0	0	0	0	0	0	0
	Red(254)	1	1	1	1	1	1	1	0	0	0	0	0	0	0	0	0	0	0	0	0	0	0	0	0
	Red(255) bright	1	1	1	1	1	1	1	1	0	0	0	0	0	0	0	0	0	0	0	0	0	0	0	0
Green	Green(000)dark	0	0	0	0	0	0	0	0	0	0	0	0	0	0	0	0	0	0	0	0	0	0	0	0
	Green(001)	0	0	0	0	0	0	0	0	0	0	0	0	0	0	0	1	0	0	0	0	0	0	0	0
	Green(002)	0	0	0	0	0	0	0	0	0	0	0	0	0	0	1	0	0	0	0	0	0	0	0	0
	:	:	:	:	:	:	:	:	:	:	:	:	:	:	:	:	:	:	:	:	:	:	:	:	:
	Green(253)	0	0	0	0	0	0	0	0	1	1	1	1	1	1	0	1	0	0	0	0	0	0	0	0
	Green(254)	0	0	0	0	0	0	0	0	1	1	1	1	1	1	1	0	0	0	0	0	0	0	0	0
	Green(255)bright	0	0	0	0	0	0	0	0	1	1	1	1	1	1	1	1	0	0	0	0	0	0	0	0
Blue	Blue(000) dark	0	0	0	0	0	0	0	0	0	0	0	0	0	0	0	0	0	0	0	0	0	0	0	0
	Blue(001)	0	0	0	0	0	0	0	0	0	0	0	0	0	0	0	0	0	0	0	0	0	0	0	1
	Blue(002)	0	0	0	0	0	0	0	0	0	0	0	0	0	0	0	0	0	0	0	0	0	0	1	0
	:	:	:	:	:	:	:	:	:	:	:	:	:	:	:	:	:	:	:	:	:	:	:	:	:
	Blue(253)	0	0	0	0	0	0	0	0	0	0	0	0	0	0	0	0	1	1	1	1	1	1	0	1
	Blue(254)	0	0	0	0	0	0	0	0	0	0	0	0	0	0	0	0	1	1	1	1	1	1	1	0
	Blue(255) bright	0	0	0	0	0	0	0	0	0	0	0	0	0	0	0	0	1	1	1	1	1	1	1	1

Product Specification

3-6. V_{LCD} Power Dip Condition

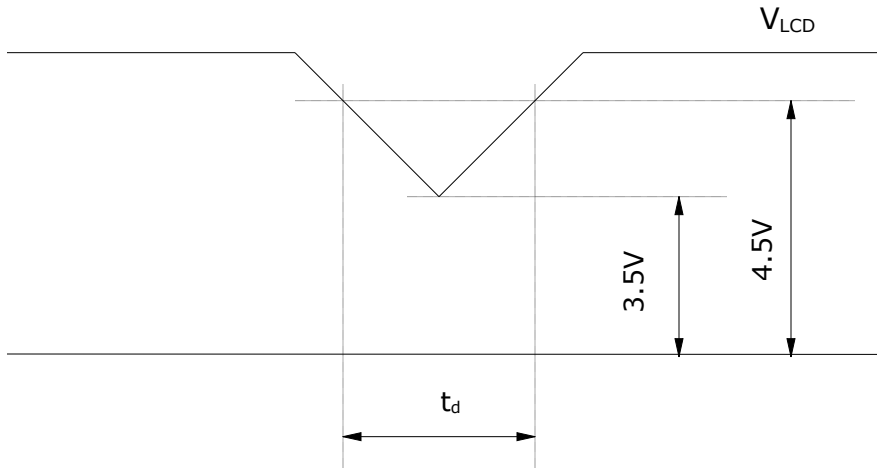

1) Dip condition

$$3.5V < V_{LCD} < 4.5V, t_d \leq 20ms$$

2) $V_{LCD} < 3.5V$

V_{LCD} -dip conditions should also follow the Power On/Off conditions for supply voltage.

Product Specification

3-7. Power Sequence

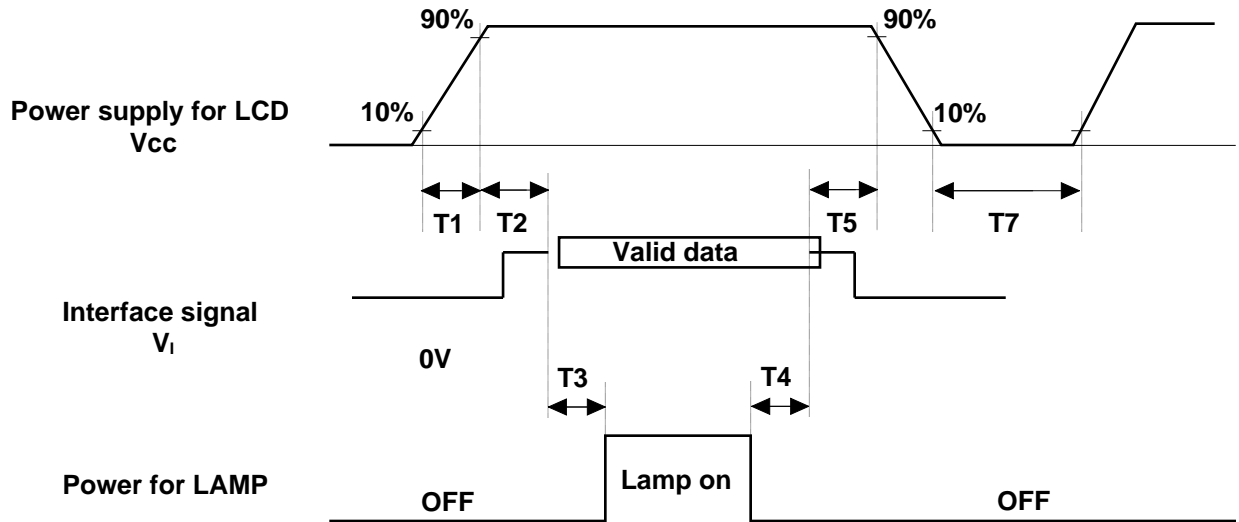

[Figure 3.] Power sequence

Table 8. Power sequence time delay

Parameter	Values			Units
	Min.	Typ.	Max.	
T ₁	0.5	-	10	ms
T ₂	0.01	-	50	ms
T ₃	500	-	-	ms
T ₄	200	-	-	ms
T ₅	0.01	-	50	ms
T ₇	1	-	-	s

- Notes :
1. Please avoid floating state of interface signal at invalid period.
 2. When the interface signal is invalid, be sure to pull down the power supply for LCD V_{CC} to 0V.
 3. Lamp power must be turn on after power supply for LCD and interface signals are valid.

Product Specification

Optical characteristics are determined after the unit has been 'ON and stable for approximately 30 minutes in a dark environment at 25 °C. The values specified are measured at an approximate distance 50cm from the LCD surface at a viewing angle of and equal to 0 °.

Figure. 3 presents additional information concerning the measurement equipment and method.

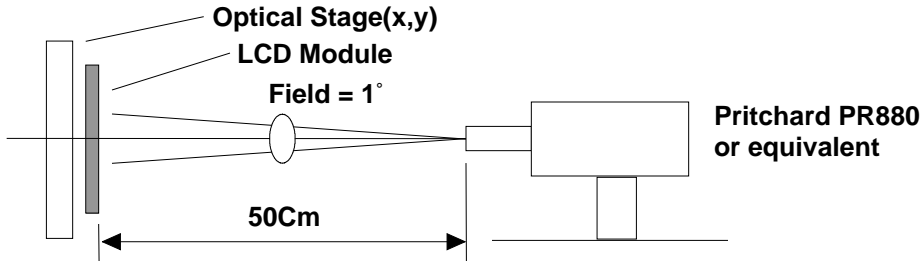

[Figure 3] Optical characteristic measurement equipment and method

Table 9. Optical characteristics

(Ta=25 °C, VCC=5.0V, fv=60Hz Dclk=54MHz, IBL=7.5mArms)

Parameter	Symbol	Values			Units	Notes
		Min.	Typ.	Max.		
Contrast ratio	CR	700	1000	-		1
Surface luminance, white	L _{WH}	250	300	-	cd/m ²	2
Luminance uniformity	△L ₉	75	-	-	%	3
Response time	T _r		5	10	ms	4
Rise time	T _{rR}	-	1.3	2.6		
Decay time	T _{rD}	-	3.7	7.4		
CIE color coordinates						
Red	XR	0.605	0.635	0.665		
	YR	0.312	0.342	0.372		
Green	XG	0.262	0.292	0.322		
	YG	0.581	0.611	0.641		
Blue	XB	0.117	0.147	0.177		
	YB	0.040	0.070	0.100		
White	XW	0.283	0.313	0.343		
	YW	0.299	0.329	0.359		
Viewing angle (by CR 10)						
X axis, right(=0°)	r	70	80	-	degree	5
X axis, left (=180°)	l	70	80	-		
Y axis, up (=90°)	u	60	75	-		
Y axis, down (=270°)	d	70	85	-		
Viewing angle (by CR 5)						
X axis, right(=0°)	r	75	88	-	degree	
X axis, left (=180°)	l	75	88	-		
Y axis, up (=90°)	u	70	85	-		
Y axis, down (=270°)	d	70	85	-		
Relative brightness				1.7		6
Luminance uniformity -						Figure 4
Angular dependence (TCO'03)				1.8	%	Figure 6
Crosstalk						

Product Specification

Notes : 1. Contrast ratio(CR) is defined mathematically as :

$$\text{Contrast ratio} = \frac{\text{Surface luminance with all white pixels}}{\text{Surface luminance with all black pixels}}$$

2. Surface luminance is the center point across the LCD surface 50cm from the surface with all pixels displaying white. For more information see [Figure 4].
When $I_{BL}=7.5\text{mA}$, $L_{WH}=250\text{cd/m}^2(\text{Min.})$ $300\text{cd/m}^2(\text{Typ.})$
3. The uniformity in surface luminance , ΔL_9 is determined by measuring L_{ON} at any point in test area. But the management of ΔL_9 is determined by measuring L_{ON} at each test position 1 through 9, and then dividing the maximum L_{ON} of 9 points luminance by minimum L_{ON} of 9 points luminance. For more information see [Figure 4].
 $\Delta L_9 = \frac{\text{Maximum } (L_{ON1}, L_{ON2}, \dots, L_{ON9})}{\text{Minimum } (L_{ON1}, L_{ON2}, \dots, L_{ON9})} \times 100 (\%)$
4. Response time is the time required for the display to transition from white to black(Rise Time, T_R) and from black to white(Decay Time, T_D). For additional information see [Figure 5].
The sampling rate is 2,500 sample/sec.
5. Viewing angle is the angle at which the contrast ratio is greater than 10. The angles are determined for the horizontal or x axis and the vertical or y axis with respect to the z axis which is normal to the LCD surface. For more information see Figure 6 .
6. Gray scale specification

Table 10. Gray scale

Gray level	Luminance(%) (Typ.)
L0	0.14
L31	1.23
L63	4.98
L95	12.30
L127	23.58
L159	40.03
L191	61.30
L223	84.03
L255	100

Product Specification

[Figure 4.] Luminance measuring point

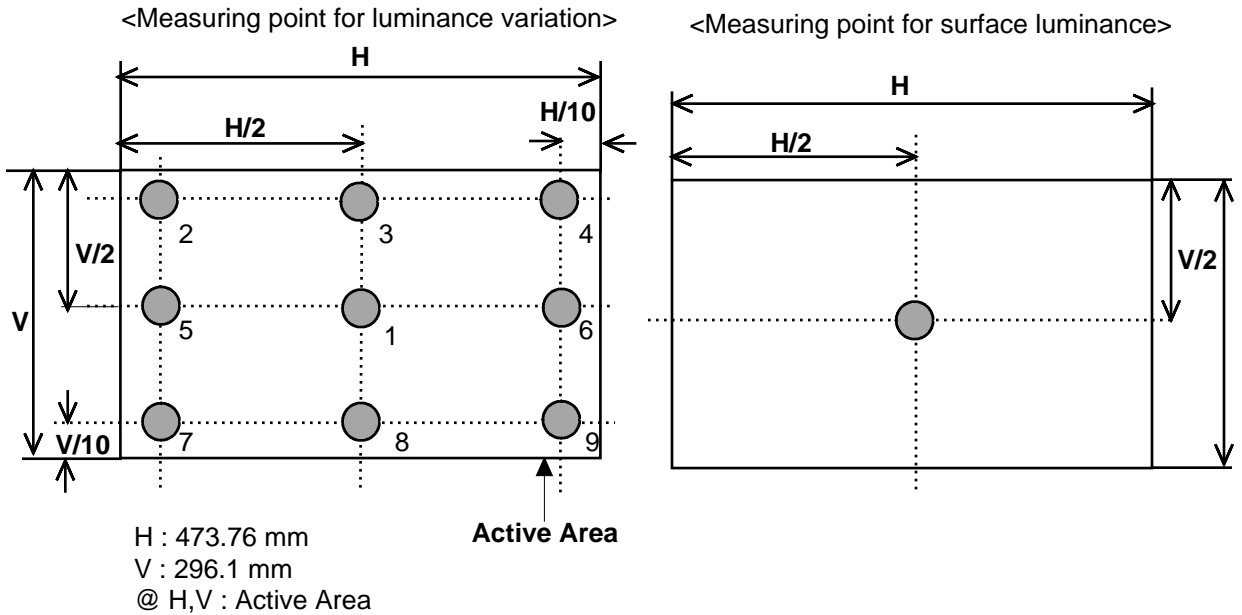

< Luminance Uniformity - angular – dependence (L_R & T_B)

TCO '03 Luminance uniformity – angular dependence, is the capacity of the VDU to present the same luminance level independently of the viewing direction. The angular-dependent luminance uniformity is calculated as the ratio of maximum luminance to minimum luminance in the specified measurement areas.

Test pattern : 80% white pattern

Test point : 2-point

Test distance : $D * 1.5 = 83.82\text{cm}$

Test method : $L_R = ((L_{\max. +30\text{deg.}} / L_{\min. +30\text{deg.}}) + (L_{\max. -30\text{deg.}} / L_{\min. -30\text{deg.}})) / 2$

$T_B = ((L_{\max. +15\text{deg.}} / L_{\min. +15\text{deg.}})$

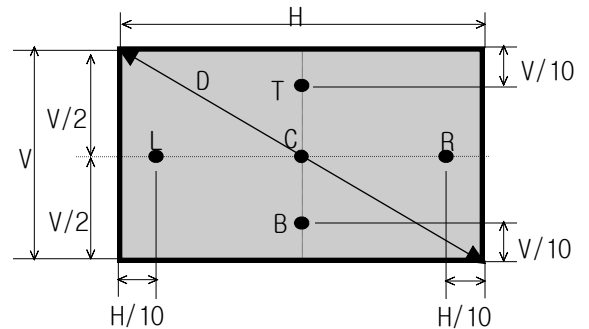

[Figure 5.] Response time

The response time is defined as the following Figure and shall be measured by switching the input signal for “black” and “white”.

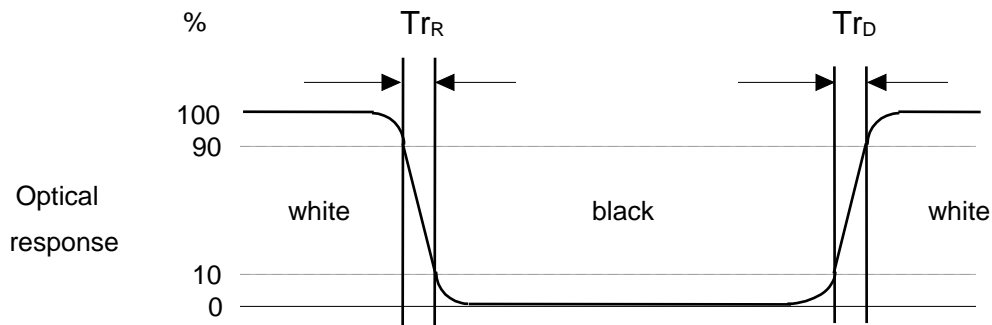

Product Specification

[Figure 6.] Viewing angle

<Dimension of viewing angle range>

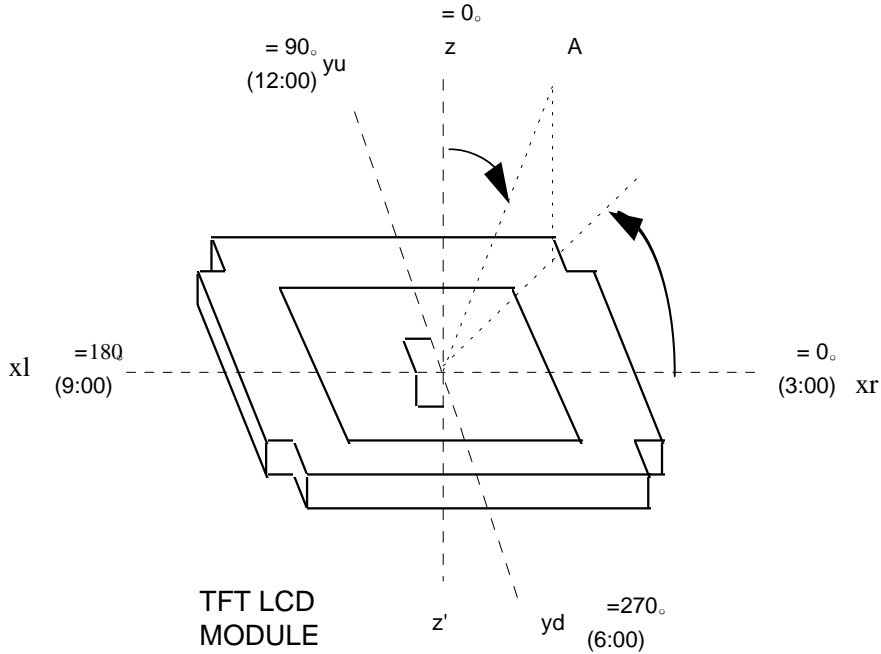

[Figure 7.] Crosstalk

The equation of crosstalk : $(L_{A[or C]2} - L_{A[or C]1} / L_{A[or C]1}) \cdot 100(\%)$ [Vertical],
 $(L_{B[or D]2} - L_{B[or D]1} / L_{B[or D]1}) \cdot 100(\%)$ [Horizontal]

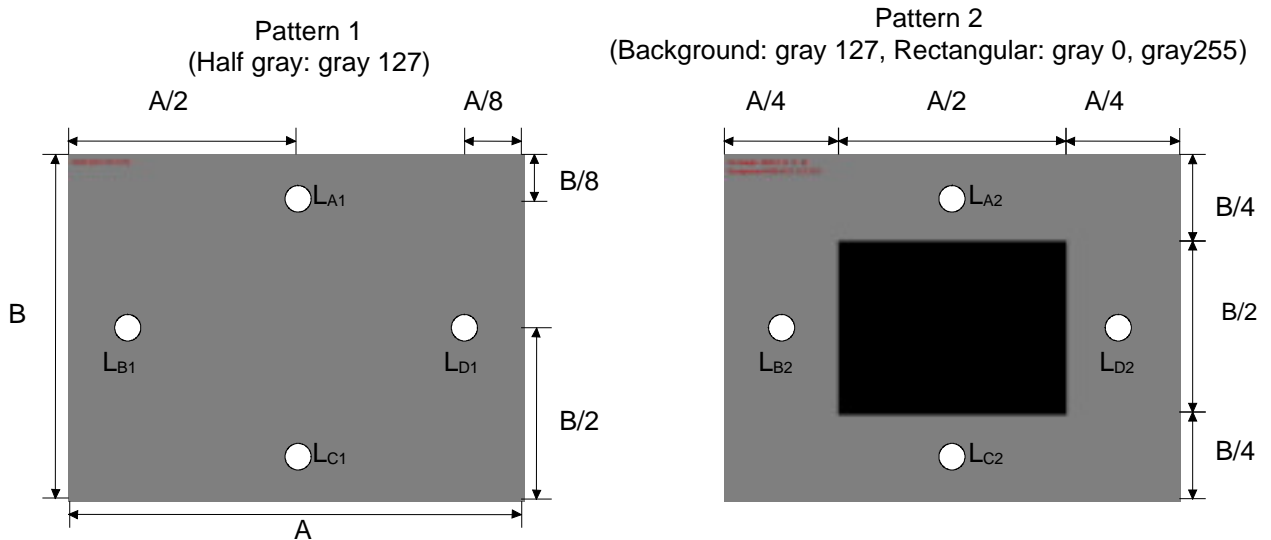

Product Specification

5. Mechanical Characteristics

Table 11. provides general mechanical characteristics for the model LM220WE1-TLD. Please refer to Figure 8, 9 regarding the detailed mechanical drawing of the LCD.

Table 11. Mechanical characteristics

Outline Dimension	Horizontal	493.7mm
	Vertical	320.1mm
	Depth	16.5mm
Bezel Area	Horizontal	477.7mm
	Vertical	300.1mm
Active Display Area	Horizontal	473.76mm
	Vertical	296.1mm
Weight	2800 g (Typ.), 2950 (Max.)	
Surface Treatment	Hard coating(2H) Glare treatment of the front polarizer	

Notes : Please refer to a mechanic drawing in terms of tolerance at the next page.

Product Specification

[Figure 8.] Front view

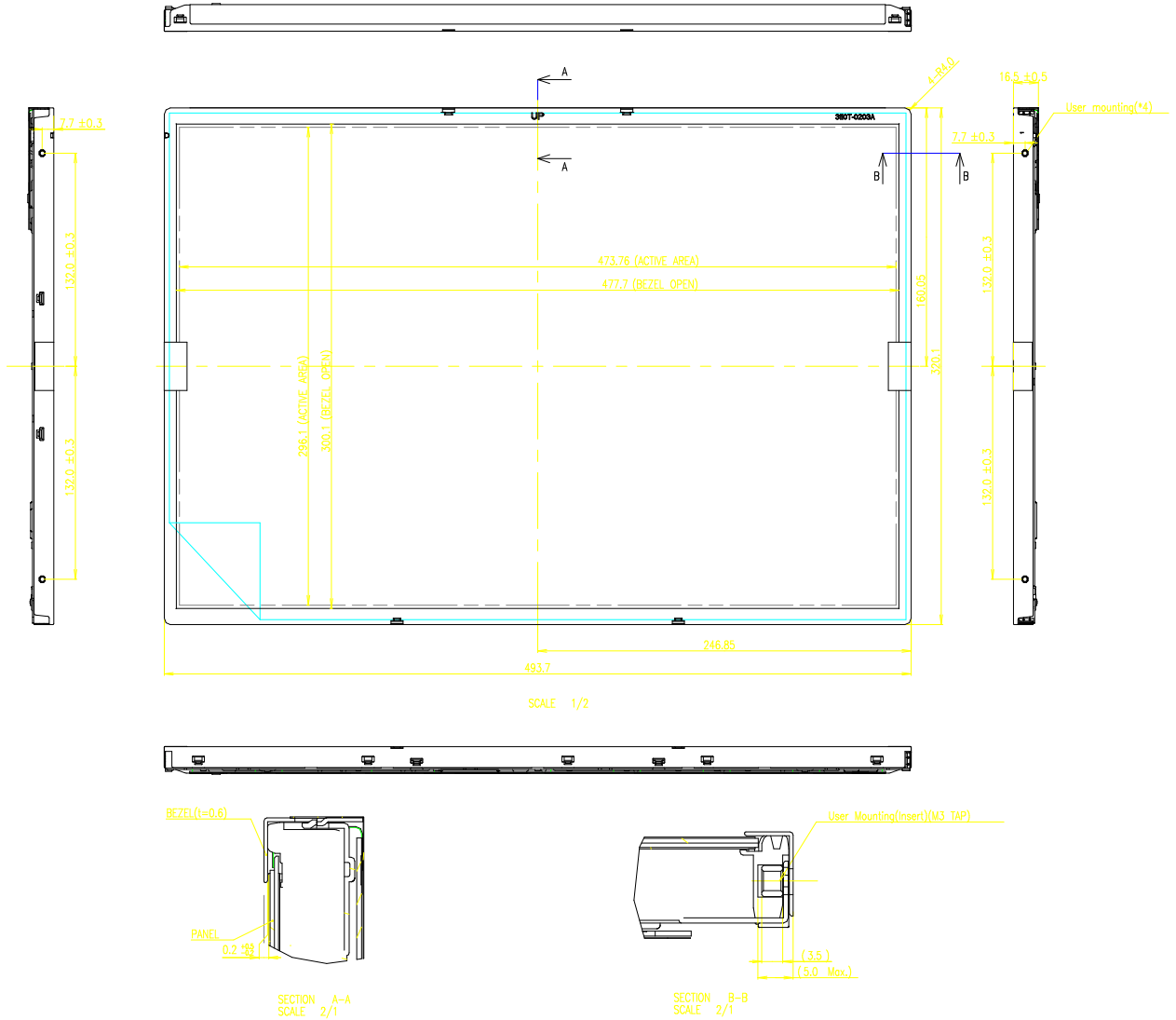

Product Specification

[Figure 9.] Rear view

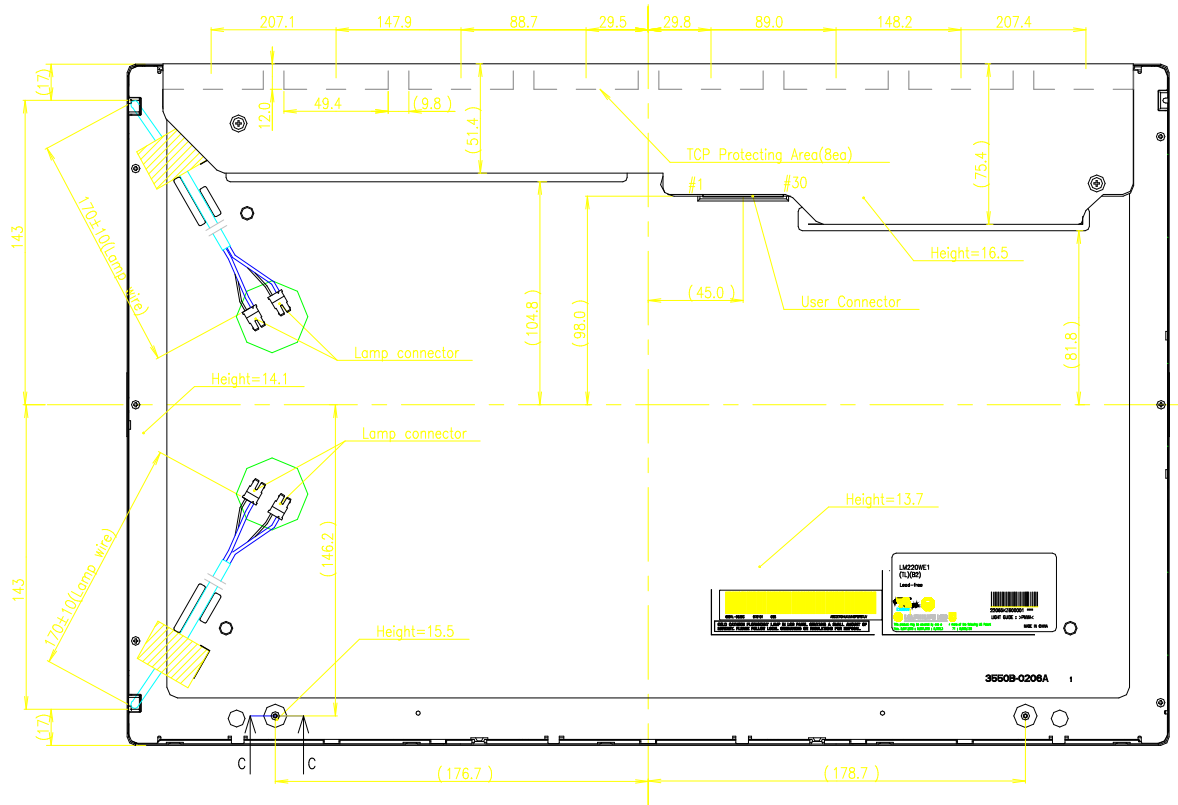

Notes

1. Backlight : 4 Cold Cathode Fluorescent Lamps
2. I/F Connector Specification : FI-XB30SRL-HF11(JAE)
3. Lamp Connector Specification
- 35001HS-D2LD(Yeonho) <2pin>
4. Torque of user hole : 3.0~4.0kgf-cm
5. Tilt and partial disposition tolerance of display area as following
(1) Y-Direction : IA-BI <= 1.0
(2) X-Direction : IC-DI <= 1.0

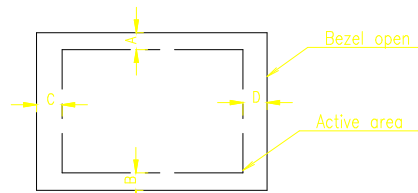
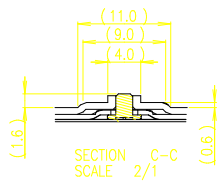

6. Lamp(CCFL) lot No. is marked at backlight connector
7. Do not wind conductive tape around the backlight wires
8. Unspecified tolerances to be $\pm 0.5\text{mm}$
9. The TCP Protecting area is weak & sensitive,
So, please don't press the Drive IC Protecting area.

Product Specification

6. Reliability

Environment test condition

No	Test Item	Condition
1	High temperature storage test	Ta= 60°C 240h
2	Low temperature storage test	Ta= -20°C 240h
3	High temperature operation test	Ta= 50°C 50%RH 240h
4	Low temperature operation test	Ta= 0°C 240h
5	Vibration test (non-operating)	Wave form : random Vibration level : 1.0G RMS Bandwidth : 10-500Hz Duration : X,Y,Z, 10 min One time each direction
6	Shock test (non-operating)	Shock level : 100G Waveform : half sine wave, 2ms Direction : ±X, ±Y, ±Z One time each direction
7	Altitude operating storage / shipment	0 - 10,000 feet(3048m) 0 - 40,000 feet(12,192m)

Product Specification

7. International Standards

7-1. Safety

- a) UL 60950-1:2003, First Edition, Underwriters Laboratories, Inc., Standard for Safety of Information Technology Equipment.
- b) CAN/CSA C22.2, No. 60950-1-03 1st Ed. April 1, 2003, Canadian Standards Association, Standard for Safety of Information Technology Equipment.
- c) EN 60950-1:2001, First Edition, European Committee for Electrotechnical Standardization(CENELEC) European Standard for Safety of Information Technology Equipment.

7-2. EMC

- a) ANSI C63.4 "Methods of Measurement of Radio-Noise Emissions from Low-Voltage Electrical and Electrical Equipment in the Range of 9kHz to 40GHz. "American National Standards Institute(ANSI), 1992
- b) C.I.S.P.R "Limits and Methods of Measurement of Radio Interface Characteristics of Information Technology Equipment." International Special Committee on Radio Interference.
- c) EN 55022 "Limits and Methods of Measurement of Radio Interface Characteristics of Information Technology Equipment." European Committee for Electrotechnical Standardization.(CENELEC), 1998 (Including A1: 2000)

Product Specification

8. Packing

8-1. Designation of Lot Mark

a) Lot Mark

A	B	C	D	E	F	G	H	I	J	K	L	M
---	---	---	---	---	---	---	---	---	---	---	---	---

A,B,C : SIZE(INCH)
E : MONTH

D : YEAR
F ~ M : SERIAL NO.

Note

1. YEAR

Year	2001	2002	2003	2004	2005	2006	2007	2008	2009	2010
Mark	1	2	3	4	5	6	7	8	9	0

2. MONTH

Month	Jan	Feb	Mar	Apr	May	Jun	Jul	Aug	Sep	Oct	Nov	Dec
Mark	1	2	3	4	5	6	7	8	9	A	B	C

b) Location of Lot Mark

Serial No. is printed on the label. The label is attached to the backside of the LCD module.
This is subject to change without prior notice.

8-2. Packing Form

a) Package quantity in one box : 7pcs

b) Box Size : 550mm × 314mm × 401mm

Product Specification

9. PRECAUTIONS

Please pay attention to the followings when you use this TFT LCD module.

9-1. MOUNTING PRECAUTIONS

- (1) You must mount a module using holes arranged in four corners or four sides.
- (2) You should consider the mounting structure so that uneven force (ex. Twisted stress) is not applied to the module. And the case on which a module is mounted should have sufficient strength so that external force is not transmitted directly to the module.
- (3) Please attach the surface transparent protective plate to the surface in order to protect the polarizer. Transparent protective plate should have sufficient strength in order to resist external force.
- (4) You should adopt radiation structure to satisfy the temperature specification.
- (5) Acetic acid type and chlorine type materials for the cover case are not desirable because the former generates corrosive gas of attacking the polarizer at high temperature and the latter causes circuit break by electro-chemical reaction.
- (6) Do not touch, push or rub the exposed polarizers with glass, tweezers or anything harder than HB pencil lead. And please do not rub with dust clothes with chemical treatment. Do not touch the surface of polarizer for bare hand or greasy cloth. (Some cosmetics are detrimental to the polarizer.)
- (7) When the surface becomes dusty, please wipe gently with absorbent cotton or other soft materials like chamois soaks with petroleum benzene. Normal-hexane is recommended for cleaning the adhesives used to attach front / rear polarizers. Do not use acetone, toluene and alcohol because they cause chemical damage to the polarizer.
- (8) Wipe off saliva or water drops as soon as possible. Their long time contact with polarizer causes deformations and color fading.

9-2. OPERATING PRECAUTIONS

- (9) Do not open the case because IC circuits do not have sufficient strength.
- (1) The spike noise causes the mis-operation of circuits. It should be lower than following voltage :
 $V = \pm 200\text{mV}$ (Over and under shoot voltage)
- (2) Response time depends on the temperature. (In lower temperature, it becomes longer.)
- (3) Brightness depends on the temperature. (In lower temperature, it becomes lower.)
And in lower temperature, response time (required time that brightness is stable after turned on) becomes longer.
- (4) Be careful for condensation at sudden temperature change. Condensation makes damage to polarizer or electrical contacted parts. And after fading condensation, smear or spot will occur.
- (5) When fixed patterns are displayed for a long time, remnant image is likely to occur.
- (6) Module has high frequency circuits. Sufficient suppression to the electromagnetic interference shall be done by system manufacturers. Grounding and shielding methods may be important to minimized the interference.
- (7) Please do not give any mechanical and/or acoustical impact to LCM. Otherwise, LCM can not be operated its full characteristics perfectly.
- (8) A screw which is fastened up the steels should be a machine screw (if not, it causes metallic foreign material and deal LCM a fatal blow)
- (9) Please do not set LCD on its edge.

Product Specification

9-3. ELECTROSTATIC DISCHARGE CONTROL

Since a module is composed of electronic circuits, it is not strong to electrostatic discharge. Make certain that treatment persons are connected to ground through wrist band etc. And don't touch interface pin directly.

9-4. PRECAUTIONS FOR STRONG LIGHT EXPOSURE

Strong light exposure causes degradation of polarizer and color filter.

9-5. STORAGE

When storing modules as spares for a long time, the following precautions are necessary.

- (1) Store them in a dark place. Do not expose the module to sunlight or fluorescent light. Keep the temperature between 5°C and 35°C at normal humidity.
- (2) The polarizer surface should not come in contact with any other object.
It is recommended that they be stored in the container in which they were shipped.

9-6. HANDLING PRECAUTIONS FOR PROTECTION FILM

- (1) The protection film is attached to the bezel with a small masking tape.
When the protection film is peeled off, static electricity is generated between the film and polarizer. This should be peeled off slowly and carefully by people who are electrically grounded and with well ion-blown equipment or in such a condition, etc.
- (2) When the module with protection film attached is stored for a long time, sometimes there remains a very small amount of glue still on the bezel after the protection film is peeled off.
- (3) You can remove the glue easily. When the glue remains on the bezel surface or its vestige is recognized, please wipe them off with absorbent cotton waste or other soft material like chamois soaked with normal-hexane.