

Product Specification

SPECIFICATION FOR APPROVAL

- () Preliminary Specification
 Final Specification

Title	23" Full HD TFT LCD
-------	----------------------------



BUYER	LGE
MODEL	

SUPPLIER	LG Display Co., Ltd.
*MODEL	LM230WF1
SUFFIX	TLA5

www.jxlcd.com

*When you obtain standard approval, please use the above model name without suffix

SIGNATURE	DATE
/	
/	
/	

APPROVED BY	DATE
K.G. Park / G.Manager	 2009.12.21
REVIEWED BY	
H.S. Kim / Manager [C]	 2009.12.21
S.Y. An / Manager [M]	 09.12.21
C.S. Shin / Manager [P]	 09.12.21
PREPARED BY	
J.A. Lee / Engineer	 09.12.21

Please return 1 copy for your confirmation
With your signature and comments.

**Product Engineering Dept.
LG Display Co., Ltd**

Product Specification
Contents

No	ITEM	Page
	COVER	1
	CONTENTS	2
	RECORD OF REVISIONS	3
1	GENERAL DESCRIPTION	4
2	ABSOLUTE MAXIMUM RATINGS	5
3	ELECTRICAL SPECIFICATIONS	6
	1) ELECTRICAL CHARACTERISTICS	6
	2) INTERFACE CONNECTIONS	9
	3) LVDS characteristics	12
	4) SIGNAL TIMING SPECIFICATIONS	15
	5) SIGNAL TIMING WAVEFORMS	16
	6) COLOR INPUT DATA REFERNECE	17
	7) POWER SEQUENCE	18
	8) POWER DIP CONDITION	19
4	OPTICAL SPECIFICATIONS	20
5	MECHANICAL CHARACTERISTICS	25
6	RELIABILITY	28
7	INTERNATIONAL STANDARDS	29
	1) SAFETY	29
	2) EMC	29
8	PACKING	30
	1) DESIGNATION OF LOT MARK	30
	2) PACKING FORM	30
9	PRECAUTIONS	31
	1) MOUNTING PRECAUTIONS	31
	2) OPERATING PRECAUTIONS	31
	3) ELECTROSTATIC DISCHARGE CONTROL	32
	4) PRECAUTIONS FOR STRONG LIGHT EXPOSURE	32
	5) STROAGE	32
	6) HANDLING PRECAUTIONS FOR PROTECTION FILM	32

Product Specification
Record of revisions

Revision No	Date	Page	Description
Ver. 0.1	Feb. 26, 2009		Preliminary Specifications.
Ver. 1.0	Dec. 21, 2009	9, 10	Change the Maker name of Interface Connector. (LSC → LSM)
		26	Add the Position of Source D-IC in Rear View Drawing. Final Specifications.

www.jxlcd.com

Product Specification

1. General description

LM230WF1-TLA5 is a Color Active Matrix Liquid Crystal Display with an integral Cold Cathode Fluorescent Lamp(CCFL) backlight system. The matrix employs a-Si Thin Film Transistor as the active element. It is a transmissive type display operating in the normally white mode. It has a 23 inch diagonally measured active display area with FHD resolution (1080 vertical by 1920 horizontal pixel array) Each pixel is divided into Red, Green and Blue sub-pixels or dots which are arranged in vertical stripes. Gray scale or the brightness of the sub-pixel color is determined with a 8-bit gray scale signal for each dot, thus, presenting a palette of more than 16,7M colors with Advanced-FRC(Frame Rate Control). It has been designed to apply the interface method that enables low power, high speed, low EMI. FPD Link or compatible must be used as a LVDS(Low Voltage Differential Signaling) chip. It is intended to support applications where thin thickness, wide viewing angle, low power are critical factors and graphic displays are important. In combination with the vertical arrangement of the sub-pixels, the LM230WF1-TLA5 characteristics provide an excellent flat panel display for office automation products such as monitors.

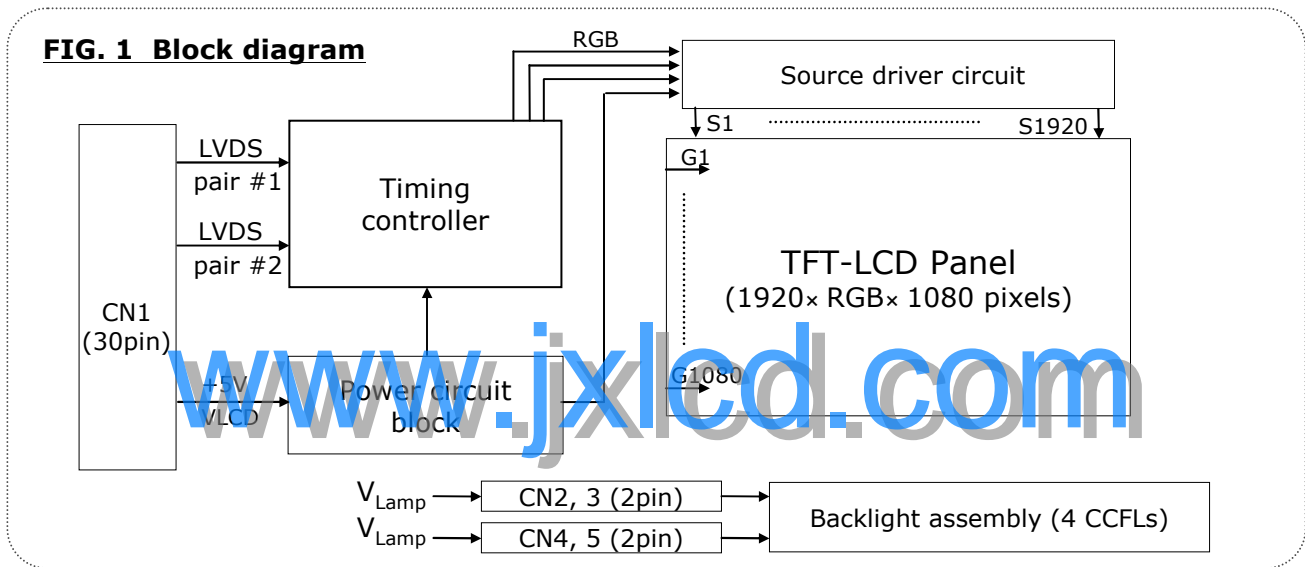

General features

Active screen size	23 inches(58.42cm) diagonal(Aspect ratio 16:9)
Outline Dimension	533.2(H) x 312.0(V) x 16.5(D) mm(Typ.)
Pixel Pitch	0.265 mm x 0.265 mm
Pixel Format	1920 horiz. By 1080 vert. Pixels RGB stripes arrangement
Interface	LVDS 2Port
Color depth	16.7M colors
Luminance, white	300 cd/m ² (Center 1Point, typ)
Viewing Angle (CR>10)	R/L 170(Typ.), U/D 160(Typ.)
Power Consumption	Total 30W (Typ.), (4.5W@V _{LCD} , 25.5W@I _{BL} =7.5mA)
Weight	2600g(typ.)
Display operating mode	Transmissive mode, normally White
Surface treatments	Hard coating(3H) & Anti-Glare treatment of the front polarizer

Product Specification

2. Absolute maximum ratings

The following are maximum values which, if exceeded, may cause faulty operation or damage to the unit.

Table 1. Absolute maximum ratings

Parameter	Symbol	Values		Units	Notes
		Min	Max		
Power Supply Input Voltage	V_{LCD}	-0.3	+6.0	Vdc	At 25°C
Operating Temperature	T_{OP}	0	50	°C	1
Storage Temperature	T_{ST}	-20	60	°C	
Operating Ambient Humidity	H_{OP}	10	90	%RH	
Storage Humidity	H_{ST}	10	90	%RH	

Note : 1. Temperature and relative humidity range are shown in the figure below.
Wet bulb temperature should be 39 °C Max, and no condensation of water.

FIG. 2 Temperature and relative humidity

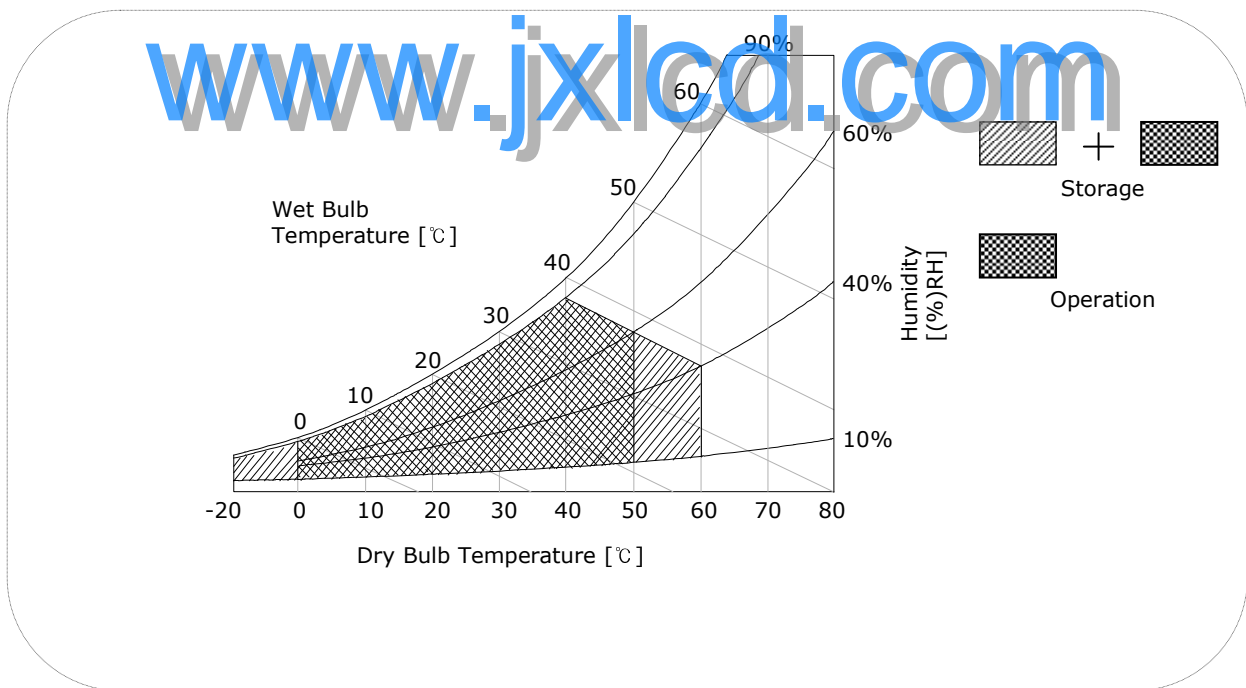

Product Specification

3. Electrical specifications

3-1. Electrical characteristics

It requires two power inputs. One is employed to power the LCD electronics and to drive the TFT array and liquid crystal. The second input power for the CCFL/Backlight, is typically generated by an inverter. The inverter is an external unit to the LCDs.

Table 2. Electrical characteristics

Parameter	Symbol	Values			Unit	Notes
		Min	Typ	Max		
MODULE :						
Power Supply Input Voltage	V_{LCD}	4.5	5.0	5.5	Vdc	
Permissive Power Input Ripple	V_{LCD}	-	-	0.4	V	3
Power Supply Input Current	$I_{LCD-MOSAIC}$	-	900	1100	mA	1
	$I_{LCD-BLACK}$	-	1050	1250	mA	2
Power Consumption	P_{LCD}	-	4.5	5.5	Watt	1
Inrush current	I_{RUSH}	-	-	3.0	A	4

Note :

1. The specified current and power consumption are under the $V_{LCD}=5.0V$, $25 \pm 2^{\circ}C$, $f_v=60Hz$ condition whereas mosaic pattern(8 x 6) is displayed and f_v is the frame frequency.
2. The current is specified at the maximum current pattern.
3. Permissive power ripple should be measured under $V_{CC}=5.0V$, $25^{\circ}C$, f_v (frame frequency)=Max condition and At that time, we recommend the bandwidth configuration of oscilloscope is to be under 20MHz.
4. The duration of rush current is about 2ms and rising time of power Input is $500\mu s \pm 20\%$.

FIG.3 pattern for Electrical characteristics

power consumption measurement

White : 255Gray
Black : 0Gray

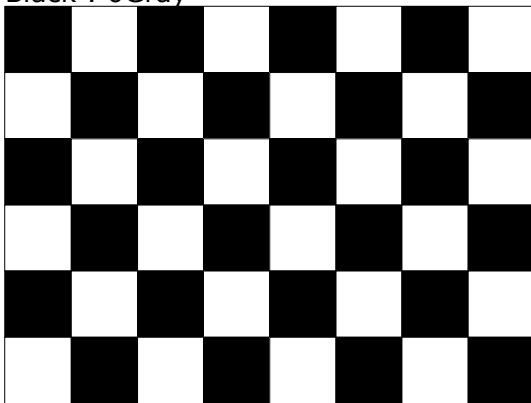

Mosaic Pattern(8 x 6)

power input ripple

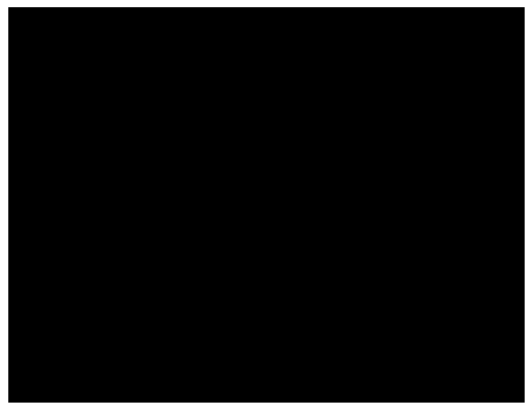

Full Black Pattern

Product Specification
Table 3. Electrical characteristics

Parameter	Symbol	Values			Unit	Notes
		Min	Typ	Max		
LAMP :						
Operating Voltage	V_{BL}	830(8.0mA)	850 (7.5mA)	1000 (3.0mA)	V_{RMS}	1, 2
Operating Current	I_{BL}	3.0	7.5	8.0	mA_{RMS}	1
Established Starting Voltage	V_S					1, 3
	at 25 °C			1500	V_{RMS}	
	at 0 °C			1800	V_{RMS}	
Operating Frequency	f_{BL}	40	60	70	kHz	4
Discharge Stabilization Time	T_S			3	Min	1, 5
Power Consumption	P_{BL}		25.5	28.1	Watt	6
Life Time		50000			Hrs	1, 7

Note :

The design of the inverter must have specifications for the lamp in LCD Assembly.

The performance of the Lamp in LCM, for example life time or brightness, is extremely influenced by the characteristics of the DC-AC inverter. So all the parameters of an inverter should be carefully designed so as not to produce too much leakage current from high-voltage output of the inverter. When you design or order the inverter, please make sure unwanted lighting caused by the mismatch of the lamp and the inverter (no lighting, flicker, etc) never occurs. When you confirm it, the LCD-Assembly should be operated in the same condition as installed in you instrument.

- ※ Do not attach a conducting tape to lamp connecting wire. If the lamp wire attach to a conducting tape, TFT-LCD Module has a low luminance and the inverter has abnormal action. Because leakage current is occurred between lamp wire and conducting tape.

- Specified values are for a single lamp.
It is only reference voltage in LCM or System.
- Operating voltage is measured at $25 \pm 2^\circ\text{C}$ and follows as below condition,
 - $\pm 10\%$ @typical operating voltage is based on single lamp.
 - $\pm 20\%$ @typical operating voltage is based on system & test equipment tolerance.
- The voltage above V_S should be applied to the lamps for more than 1 second for start-up.
(Inverter open voltage must be more than lamp starting voltage.)
Otherwise, the lamps may not be turned on. The used lamp current is the lamp typical current.
- Lamp frequency may produce interface with horizontal synchronous frequency and as a result this may cause beat on the display. Therefore lamp frequency shall be as away possible from the horizontal synchronous frequency and from its harmonics in order to prevent interference.
- Let's define the brightness of the lamp after being lighted for 5 minutes as 100%.
 T_S is the time required for the brightness of the center of the lamp to be not less than 95%.
- The lamp power consumption shown above does not include loss of external inverter.
The used lamp current is the lamp typical current. ($P_{BL} = V_{BL} \times I_{BL} \times N_{Lamp}$)
- The life is determined as the time at which brightness of the lamp is 50% compared to that of initial value at the typical lamp current on condition of continuous operating at $25 \pm 2^\circ\text{C}$.

Product Specification

Note :

8. The output of the inverter must have symmetrical(negative and positive) voltage waveform and symmetrical current waveform (Unsymmetrical ratio is less than 10%). Please do not use the inverter which has unsymmetrical voltage and unsymmetrical current and spike wave. Requirements for a system inverter design, which is intended to have a better display performance, a better power efficiency and a more reliable lamp, are following.It shall help increase the lamp lifetime and reduce leakage current.

- a. The asymmetry rate of the inverter waveform should be less than 10%.
- b. The distortion rate of the waveform should be within $\sqrt{2} \pm 10\%$.

* Inverter output waveform had better be more similar to ideal sine wave.

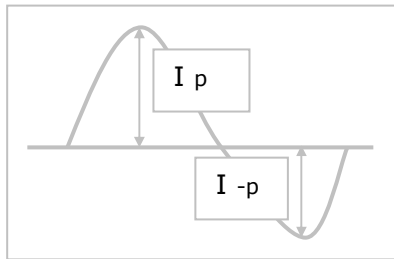

* Asymmetry rate:

$$| I_p - I_{-p} | / I_{rms} \times 100\%$$
 * Distortion rate

$$I_p \text{ (or } I_{-p}) / I_{rms}$$

www.jxlcd.com

9. The inverter which is combined with this LCM, is highly recommended to connect coupling(ballast) condenser at the high voltage output side. When you use the inverter which has not coupling(ballast) condenser, it may cause abnormal lamp lighting because of biased mercury as time goes.

10.In case of edgy type back light with over 4 parallel lamps, input current and voltage wave form should be synchronized

Product Specification

3-2. Interface connections

LCD connector(CN1) : GT103-30S-H23 (LSM) , IS100-L30B-C23 (UJU)

Mating connector : FI-X30H and FI-X30HL (JAE) or Equivalent

Table 4. Module connector(CN1) pin configuration

Pin No	Symbol	Description
1	RX00-	Minus signal of 1st channel 0 (LVDS)
2	RX00+	Plus signal of 1st channel 0 (LVDS)
3	RX01-	Minus signal of 1st channel 1 (LVDS)
4	RX01+	Plus signal of 1st channel 1 (LVDS)
5	RX02-	Minus signal of 1st channel 2 (LVDS)
6	RX02+	Plus signal of 1st channel 2 (LVDS)
7	GND	Ground
8	RXOC-	Minus signal of 1st clock channel (LVDS)
9	RXOC+	Plus signal of 1st clock channel (LVDS)
10	RX03-	Minus signal of 1st channel 3 (LVDS)
11	RX03+	Plus signal of 1st channel 3 (LVDS)
12	RXE0-	Minus signal of 2nd channel 0 (LVDS)
13	RXE0+	Plus signal of 2nd channel 0 (LVDS)
14	GND	Ground
15	RXE1-	Minus signal of 2nd channel 1 (LVDS)
16	RXE1+	Plus signal of 2nd channel 1 (LVDS)
17	GND	Ground
18	RXE2-	Minus signal of 2nd channel 2 (LVDS)
19	RXE2+	Plus signal of 2nd channel 2 (LVDS)
20	RXEC-	Minus signal of 2nd clock channel (LVDS)
21	RXEC+	Plus signal of 2nd clock channel (LVDS)
22	RXE3-	Minus signal of 2nd channel 3 (LVDS)
23	RXE3+	Plus signal of 2nd channel 3 (LVDS)
24	GND	Ground
25	NC	No Connection (For LCD internal use only.)
26	NC	No Connection (For LCD internal use only.)
27	NC	No Connection (For LCD internal use only.)
28	V _{LCD}	Power Supply (5.0V)
29	V _{LCD}	Power Supply (5.0V)
30	V _{LCD}	Power Supply (5.0V)

First Pixel data

Second Pixel data

Product Specification

FIG. 4 Connector diagram

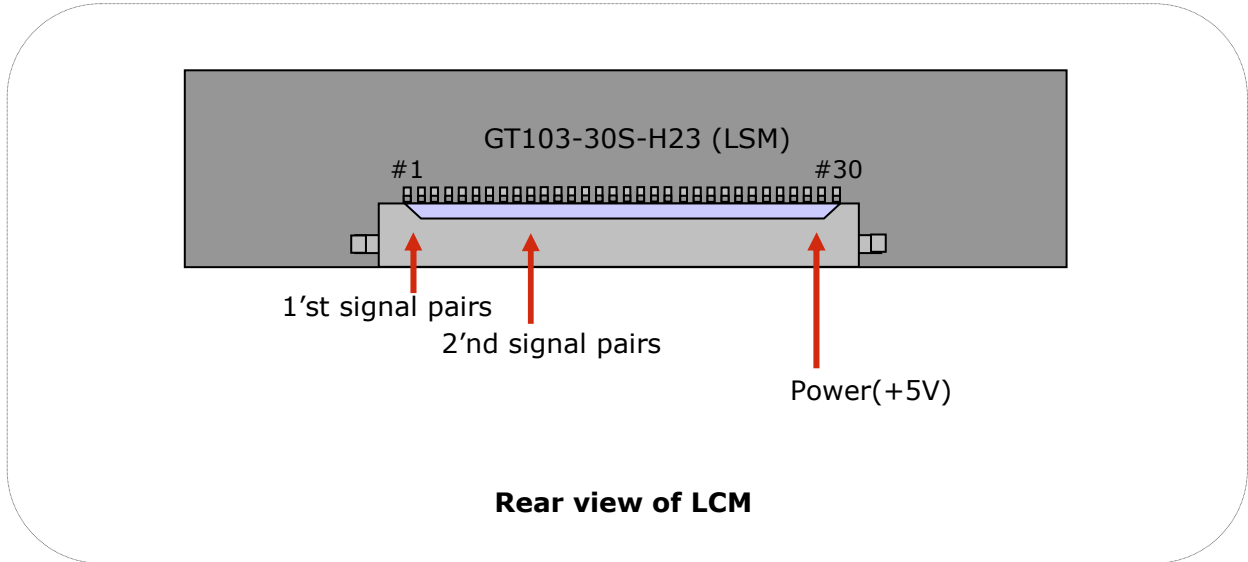

Note:

1. NC: No Connection.
2. All GND(ground) pins should be connected together and to Vss which should also be connected to the LCD's metal frame.
3. All V_{LCD} (power input) pins should be connected together.
4. Input Level of LVDS signal is based on the IEA 664 Standard.

Product Specification

The backlight interface connector is a model 35001HS-02LD manufactured by YEONHO. The mating connector part number are 35001WR-02L(2pin) or equivalent. The pin configuration for the connector is shown in the table below.

Table 5. Backlight connector pin configuration(CN2,CN3,CN4,CN5)

Pin	Symbol	Description	Notes
1	HV	High Voltage for Lamp	1
2	LV	Low Voltage for Lamp	2

- Note :
1. The high voltage power terminal is colored White,Gray
 2. The low voltage pin color is White, Black.
 3. The backlight ground should be common with LCD metal frame.

FIG. 5 Backlight connector view

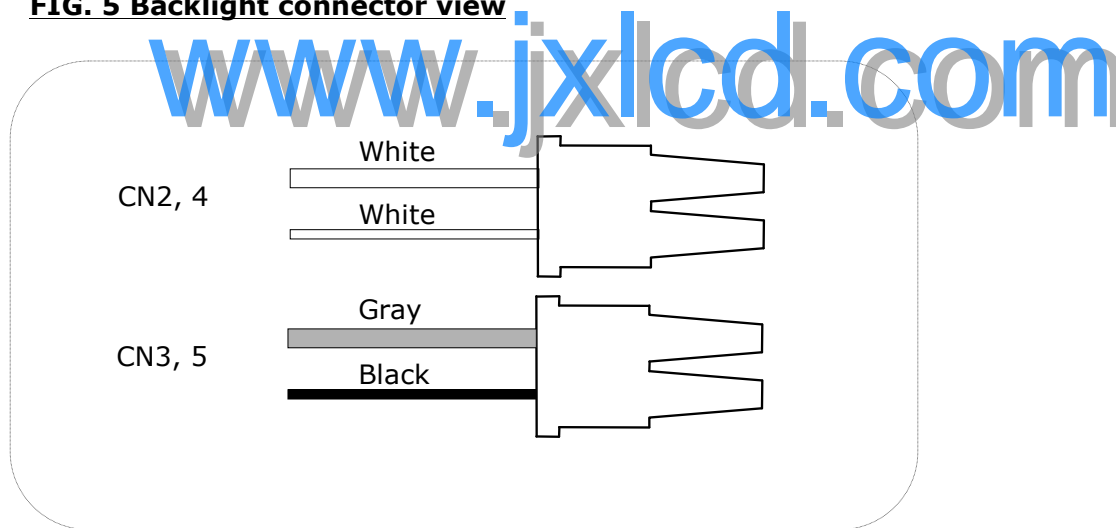

Product Specification

3-3. LVDS characteristics

3-3-1. DC Specification

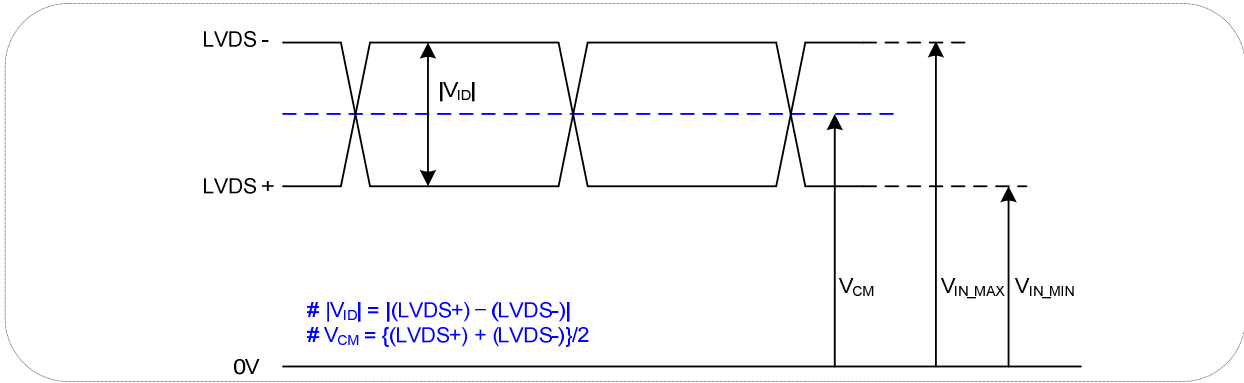

Description	Symbol	Min	Max	Unit	Notes
LVDS Differential Voltage	$ V_{ID} $	200	600	mV	-
LVDS Common mode Voltage	V_{CM}	0.6	1.8	V	-
LVDS Input Voltage Range	V_{IN}	0.3	2.1	V	-

www.jxlcd.com

3-3-2. AC Specification

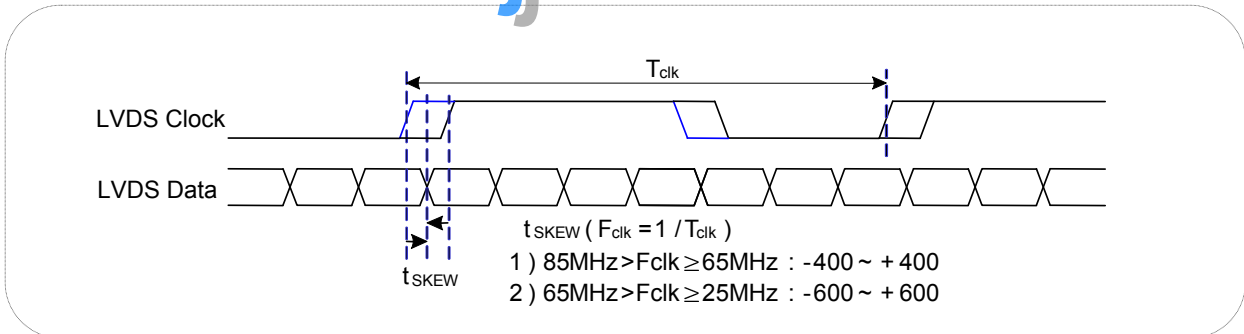

Description	Symbol	Min	Max	Unit	Notes
LVDS Clock to Data Skew Margin	t_{SKEW}	-400	+400	ps	$85MHz > F_{clk} \geq 65MHz$
	t_{SKEW}	-600	+600	ps	$65MHz > F_{clk} \geq 25MHz$
LVDS Clock to Clock Skew Margin (Even to Odd)	t_{SKEW_EO}	-1/7	+1/7	T_{clk}	-

Product Specification

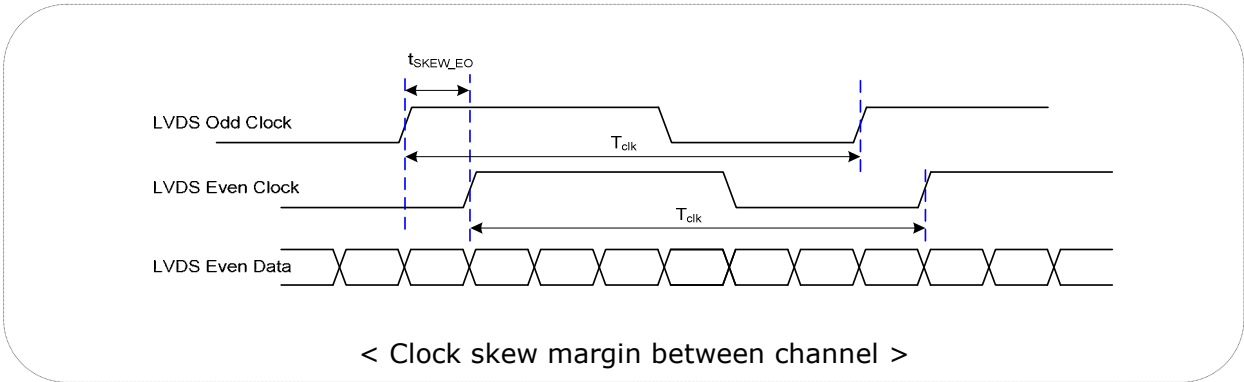

3-3-3. LVDS Data format

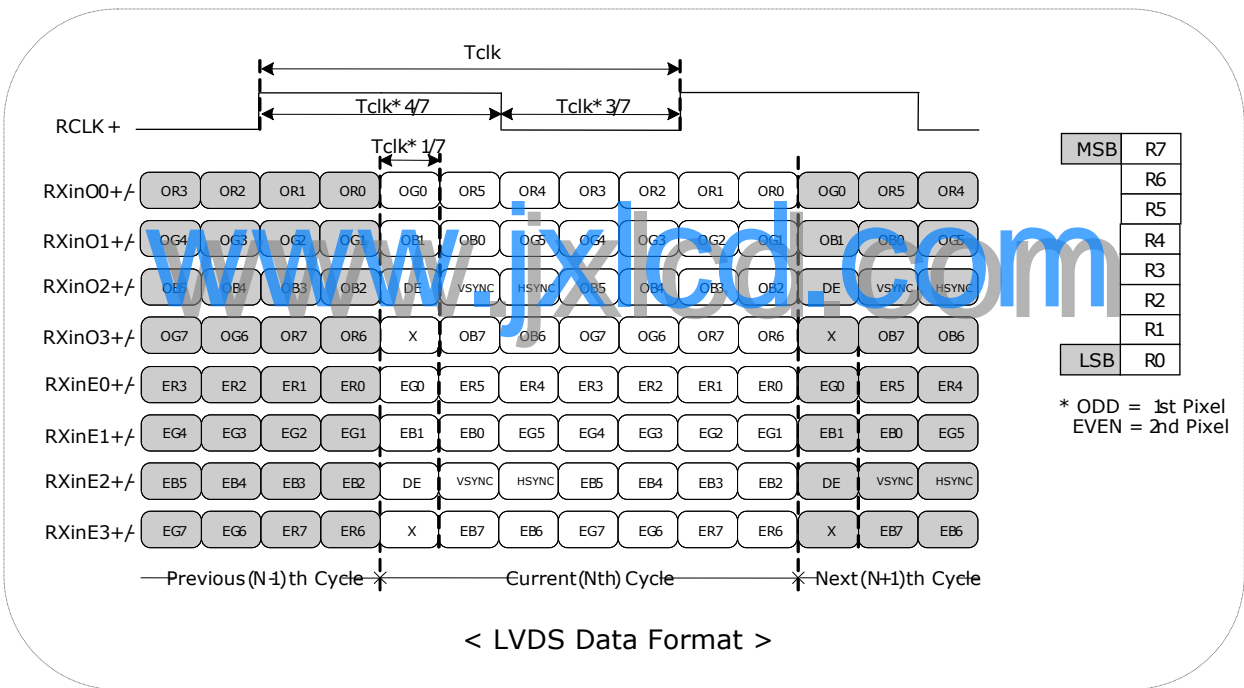

Product Specification
Table 6. Required signal assignment for Flat Link(NS:DS90CF383) transmitter

Pin #	Pin Name	Require Signal	Pin #	Pin Name	Require Signal
1	VCC	Power Supply for TTL Input	29	GND	Ground pin for TTL
2	D5	TTL Input (R7)	30	D26	TTL Input (DE)
3	D6	TTL Input (R5)	31	T _x CLKIN	TTL Level clock Input
4	D7	TTL Input (G0)	32	PWR DWN	Power Down Input
5	GND	Ground pin for TTL	33	PLL GND	Ground pin for PLL
6	D8	TTL Input (G1)	34	PLL VCC	Power Supply for PLL
7	D9	TTL Input (G2)	35	PLL GND	Ground pin for PLL
8	D10	TTL Input (G6)	36	LVDS GND	Ground pin for LVDS
9	VCC	Power Supply for TTL Input	37	TxOUT3+	Positive LVDS differential data output 3
10	D11	TTL Input (G7)	38	TxOUT3-	Negative LVDS differential data output 3
11	D12	TTL Input (G3)	39	T _x CLKOUT+	Positive LVDS differential clock output
12	D13	TTL Input (G4)	40	T _x CLKOUT-	Negative LVDS differential clock output
13	GND	Ground pin for TTL	41	T _x OUT2+	Positive LVDS differential data output 2
14	D14	TTL Input (G5)	42	T _x OUT2-	Negative LVDS differential data output 2
15	D15	TTL Input (B0)	43	LVDS GND	Ground pin for LVDS
16	D16	TTL Input (B6)	44	LVDS VCC	Power Supply for LVDS
17	VCC	Power Supply for TTL Input	45	T _x OUT1+	Positive LVDS differential data output 1
18	D17	TTL Input (B7)	46	T _x OUT1-	Negative LVDS differential data output 1
19	D18	TTL Input (B1)	47	T _x OUT0+	Positive LVDS differential data output 0
20	D19	TTL Input (B2)	48	T _x OUT0-	Negative LVDS differential data output 0
21	GND	Ground pin for TTL Input	49	LVDS GND	Ground pin for LVDS
22	D20	TTL Input (B3)	50	D27	TTL Input (R6)
23	D21	TTL Input (B4)	51	D0	TTL Input (R0)
24	D22	TTL Input (B5)	52	D1	TTL Input (R1)
25	D23	TTL Input (RSVD)	53	GND	Ground pin for TTL
26	VCC	Power Supply for TTL Input	54	D2	TTL Input (R2)
27	D24	TTL Input (HSYNC)	55	D3	TTL Input (R3)
28	D25	TTL Input (VSYNC)	56	D4	TTL Input (R4)

Notes : 1. Refer to LVDS Transmitter Data Sheet for detail descriptions.
 2. 7 means MSB and 0 means LSB at R,G,B pixel data

Product Specification
3-4. Signal timing specifications

This is the signal timing required at the input of the User connector. All of the interface signal timing should be satisfied with the following specifications for its proper operation.

Table 7. Timing table

Parameter		Symbol	Min.	Typ.	Max.	Unit	Notes
D _{CLK}	Period	t _{CLK}	11.43	13.89	16.7	ns	Pixel frequency : Typ.144MHz
	Frequency	f _{CLK}	60	72	87.5	MHz	
Horizontal	Horizontal Valid	t _{HV}	1000	1088	1120	t _{CLK}	
	H Period Total	t _{HP}	960	960	960		
	Hsync Frequency	f _H	64	66	83	kHz	
Vertical	Vertical Valid	t _{VV}	1090	1100	1160	t _{HP}	
	V Period Total	t _{VP}	1080	1080	1080		
	Vsync Frequency	f _V	50	60	75	Hz	
DE (Data Enable)	DE Setup Time	t _{SI}	4	-	-	ns	For D _{CLK}
	DE Hold Time	t _{HI}	4	-	-		
Data	Data Setup Time	t _{SD}	4	-	-	ns	For D _{CLK}
	Data Hold Time	t _{HD}	4	-	-		

Note: Hsync period and Hsync width-active should be even number times of t_{CLK}. If the value is odd number times of t_{CLK}, display control signal can be asynchronous. In order to operate this LCM a Hsync, Vsync, and DE(data enable) signals should be used.

1. The performance of the electro-optical characteristics may be influenced by variance of the vertical refresh rates.
2. Vsync and Hsync should be keep the above specification.
3. Hsync Period, Hsync Width, and Horizontal Back Porch should be any times of of character number(4).
4. The polarity of Hsync, Vsync is not restricted.
- 5, The Max frequency of 1920X1080 resolution is 82.5Mhz

Product Specification

3-5. Signal timing waveforms

1. DCLK, DE, DATA waveforms

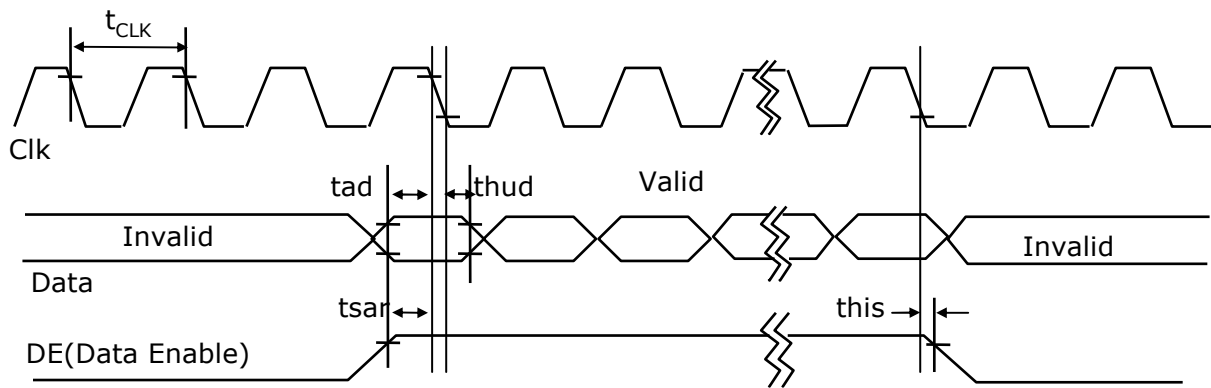

2. Horizontal waveform

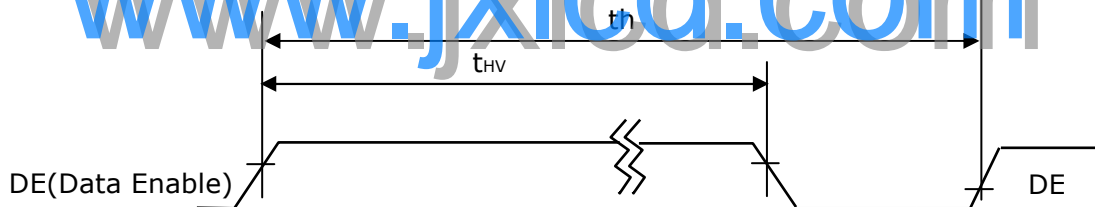

3. Vertical waveform

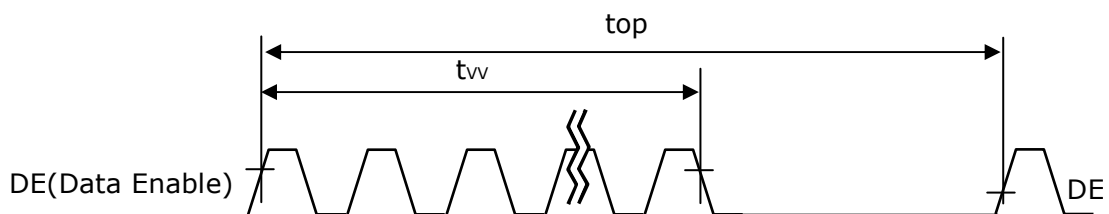

Product Specification
3-6. Color input data reference

The brightness of each primary color (red, green and blue) is based on the 8bit gray scale data input for the color ; the higher the binary input, the brighter the color. The table below provides a reference for color versus data input.

Table 8. Color data reference

Color		Input Color Data																							
		Red								Green								Blue							
		MSB				LSB				MSB				LSB				MSB				LSB			
		R7	R6	R5	R4	R3	R2	R1	R0	G7	G6	G5	G4	G3	G2	G1	G0	B7	B6	B5	B4	B3	B2	B1	B0
Basic Color	Black	0	0	0	0	0	0	0	0	0	0	0	0	0	0	0	0	0	0	0	0	0	0	0	0
	Red (255)	1	1	1	1	1	1	1	1	0	0	0	0	0	0	0	0	0	0	0	0	0	0	0	0
	Green (255)	0	0	0	0	0	0	0	0	1	1	1	1	1	1	1	1	0	0	0	0	0	0	0	0
	Blue (255)	0	0	0	0	0	0	0	0	0	0	0	0	0	0	0	0	1	1	1	1	1	1	1	1
	Cyan	0	0	0	0	0	0	0	0	1	1	1	1	1	1	1	1	1	1	1	1	1	1	1	1
	Magenta	1	1	1	1	1	1	1	1	0	0	0	0	0	0	0	0	1	1	1	1	1	1	1	1
	Yellow	1	1	1	1	1	1	1	1	1	1	1	1	1	1	1	1	0	0	0	0	0	0	0	0
	White	1	1	1	1	1	1	1	1	1	1	1	1	1	1	1	1	1	1	1	1	1	1	1	1
Red	Red(000) Dark	0	0	0	0	0	0	0	0	0	0	0	0	0	0	0	0	0	0	0	0	0	0	0	0
	Red(001)	0	0	0	0	0	0	0	1	0	0	0	0	0	0	0	0	0	0	0	0	0	0	0	0
	Red(002)	0	0	0	0	0	0	0	1	0	0	0	0	0	0	0	0	0	0	0	0	0	0	0	0
	-----	-	-	-	-	-	-	-	-	-	-	-	-	-	-	-	-	-	-	-	-	-	-	-	-
	-----	-	-	-	-	-	-	-	-	-	-	-	-	-	-	-	-	-	-	-	-	-	-	-	-
	Red(253)	1	1	1	1	1	1	0	1	0	0	0	0	0	0	0	0	0	0	0	0	0	0	0	0
	Red(254)	1	1	1	1	1	1	1	0	0	0	0	0	0	0	0	0	0	0	0	0	0	0	0	0
Red(255) Bright	1	1	1	1	1	1	1	1	0	0	0	0	0	0	0	0	0	0	0	0	0	0	0	0	
Green	Green(000) Dark	0	0	0	0	0	0	0	0	0	0	0	0	0	0	0	0	0	0	0	0	0	0	0	0
	Green(001)	0	0	0	0	0	0	0	0	0	0	0	0	0	0	1	0	0	0	0	0	0	0	0	0
	Green(002)	0	0	0	0	0	0	0	0	0	0	0	0	0	1	0	0	0	0	0	0	0	0	0	0
	-----	-	-	-	-	-	-	-	-	-	-	-	-	-	-	-	-	-	-	-	-	-	-	-	-
	-----	-	-	-	-	-	-	-	-	-	-	-	-	-	-	-	-	-	-	-	-	-	-	-	-
	Green(253)	0	0	0	0	0	0	0	0	1	1	1	1	1	1	0	1	0	0	0	0	0	0	0	0
	Green(254)	0	0	0	0	0	0	0	0	1	1	1	1	1	1	1	0	0	0	0	0	0	0	0	0
Green(255)Bright	0	0	0	0	0	0	0	0	1	1	1	1	1	1	1	1	0	0	0	0	0	0	0	0	
Blue	Blue(000) Dark	0	0	0	0	0	0	0	0	0	0	0	0	0	0	0	0	0	0	0	0	0	0	0	0
	Blue(001)	0	0	0	0	0	0	0	0	0	0	0	0	0	0	0	0	0	0	0	0	0	0	0	1
	Blue(002)	0	0	0	0	0	0	0	0	0	0	0	0	0	0	0	0	0	0	0	0	0	0	1	0
	-----	-	-	-	-	-	-	-	-	-	-	-	-	-	-	-	-	-	-	-	-	-	-	-	-
	-----	-	-	-	-	-	-	-	-	-	-	-	-	-	-	-	-	-	-	-	-	-	-	-	-
	Blue(253)	0	0	0	0	0	0	0	0	0	0	0	0	0	0	0	1	1	1	1	1	1	1	0	1
	Blue(254)	0	0	0	0	0	0	0	0	0	0	0	0	0	0	0	1	1	1	1	1	1	1	1	0
Blue(255) Bright	0	0	0	0	0	0	0	0	0	0	0	0	0	0	0	1	1	1	1	1	1	1	1	1	

Product Specification

3-7. Power sequence

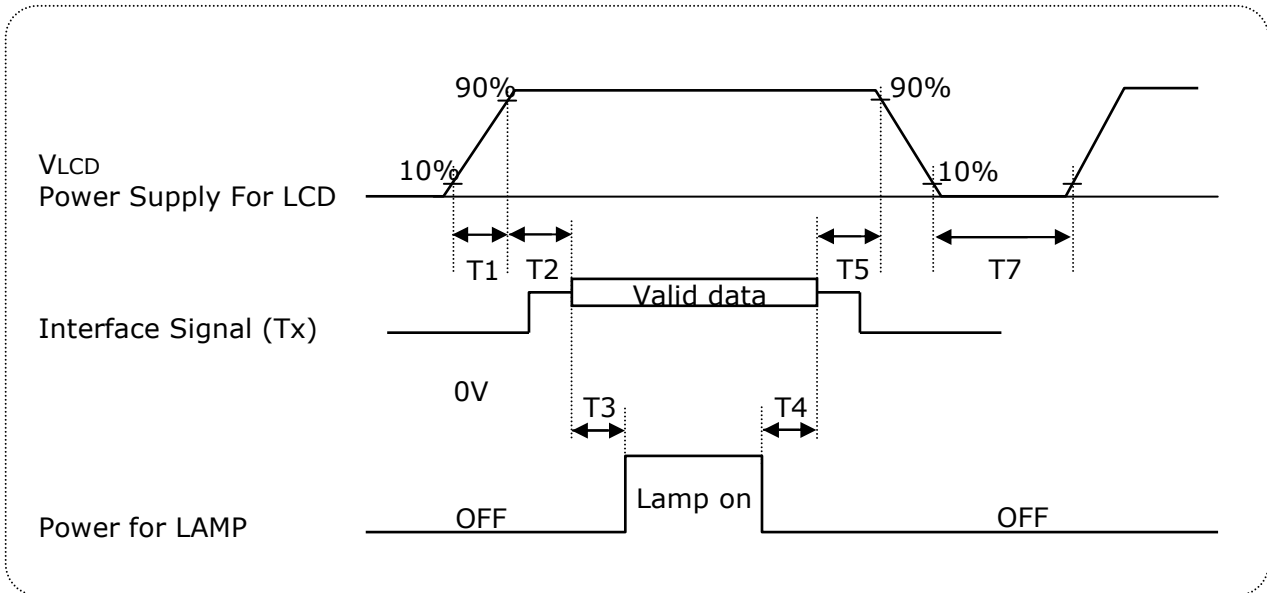

Table 9. Power sequence

Parameter	Values			Units
	Min	Typ	Max	
T1	0.5	-	10	ms
T2	0.01	-	50	ms
T3	500	-	-	ms
T4	200	-	-	ms
T5	0.01	-	50	ms
T7	1	-	-	s

Notes :

1. Please V_{LCD} power on only after connecting interface cable to LCD.
2. Please avoid floating state of interface signal at invalid period.
3. When the interface signal is invalid, be sure to pull down the power supply for LCD V_{LCD} to 0V.
4. Lamp power must be turn on after power supply for LCD an interface signal are valid.

3-8. V_{LCD} Power dip condition

FIG. 6 Power dip condition

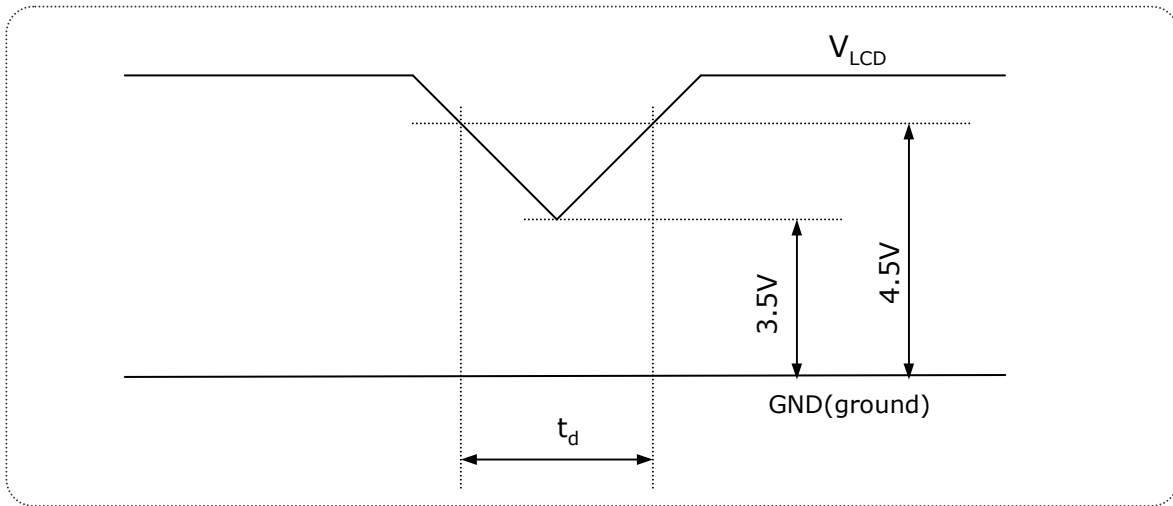

1) Dip condition

$3.5V \leq V_{LCD} < 4.5V, t_d \leq 20ms$

2) $V_{LCD} < 3.5V$

V_{LCD} -dip conditions should also follow the Power On/Off conditions for supply voltage.

Product Specification

4. Optical specification

Optical characteristics are determined after the unit has been 'ON' for 30 minutes in a dark environment at 25°C. The values specified are at an approximate distance 50cm from the LCD surface at a viewing angle of Φ and θ equal to 0°.

FIG. 7 presents additional information concerning the measurement equipment and method.

FIG. 7 Optical characteristic measurement equipment and method

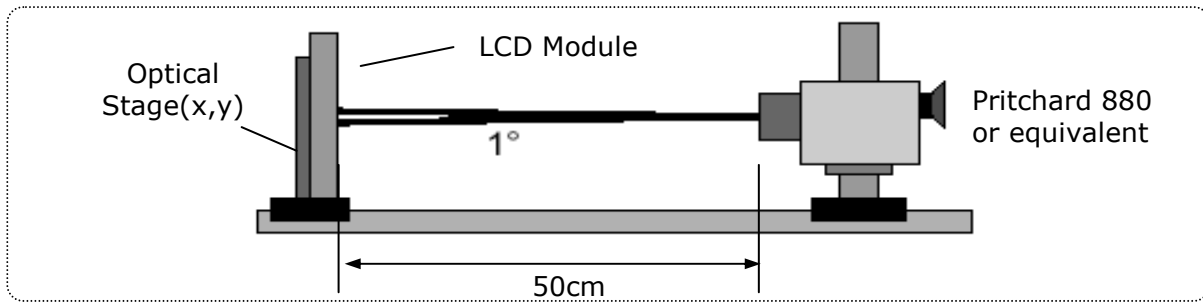

Table 10. Optical characteristics

Ta= 25°C, V_{LCD}=5.0V, f_v=60Hz f_{CLK}=72MHz, I_{BL}=7.5mA

Parameter	Symbol	Values			Units	Notes	
		Min	Typ	Max			
Contrast Ratio	CR	700	1000	-		1	
Surface Luminance, white	L _{WH}	250	300	-	cd/m ²	2	
Luminance Variation	δ_{WHITE} 9P	75			%	3	
Response Time	Rise Time Tr _R		1.3	2.6	ms	4	
	Decay Time Tr _D		3.7	7.4	ms	4	
Color Coordinates [CIE1931]	RED	Rx		0.644			
		Ry		0.336			
	GREEN	Gx		0.301			
		Gy	Typ	0.611	Typ		
	BLUE	Bx	-0.03	0.146	+0.03		
		By		0.070			
	WHITE	Wx		0.313			
		Wy		0.329			
Viewing Angle (CR>5)							
	x axis, right($\phi=0^\circ$)	θ_r	75	88		Degree	5
	x axis, left ($\phi=180^\circ$)	θ_l	75	88			
	y axis, up ($\phi=90^\circ$)	θ_u	70	85			
	y axis, down ($\phi=270^\circ$)	θ_d	70	85			
Viewing Angle (CR>10)							
	x axis, right($\phi=0^\circ$)	θ_r	70	85		Degree	5
	x axis, left ($\phi=180^\circ$)	θ_l	70	85			
	y axis, up ($\phi=90^\circ$)	θ_u	60	75			
	y axis, down ($\phi=270^\circ$)	θ_d	70	85			
Crosstalk				1.5	%	7	

Product Specification

Notes :

1. Contrast ratio(CR) is defined mathematically as :It is measured at center point(1)

$$\text{Contrast ratio} = \frac{\text{Surface luminance with all white pixels}}{\text{Surface luminance with all black pixels}}$$

2. Surface luminance is the luminance value at center 1 point(1) across the LCD surface 50cm from the surface with all pixels displaying white. For more information see FIG 8.

3. The variation in surface luminance , δ_{WHITE} is defined as

$$\delta_{\text{WHITE}} = \frac{\text{Minimum (P1,P2P9)}}{\text{Maximum (P1,P2P9)}} * 100$$

For more information see Figure 8.

FIG. 8 Luminance measuring point

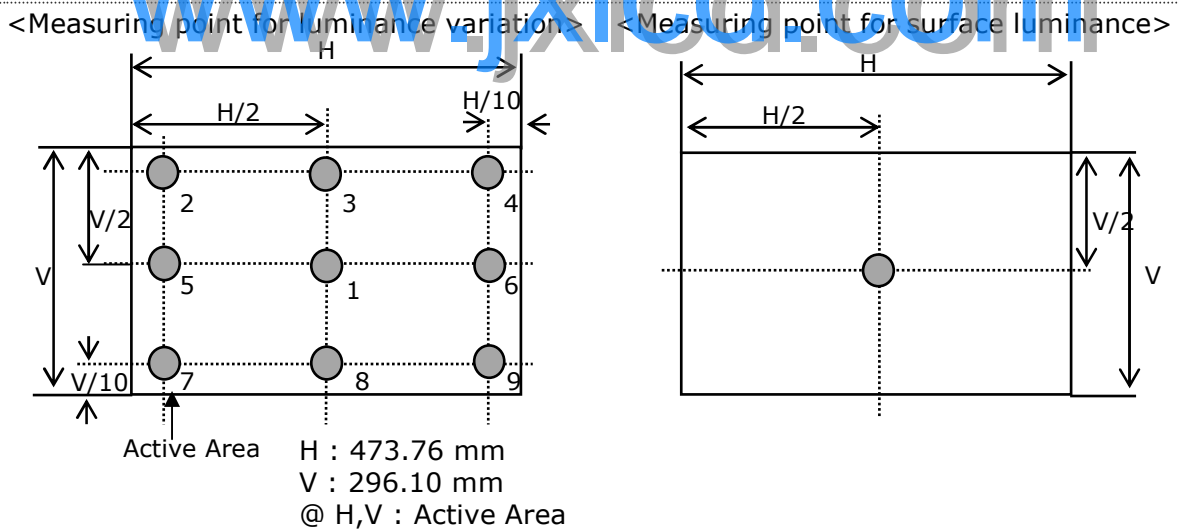

Product Specification

Notes :

- Response time is the time required for the display to transition from black to white (Decay Time, Tr_D) and from white to black (Rise Time, Tr_R)
The sampling rate is 2,500 sample/sec. For additional information see FIG. 9.

The response time is defined as the following figure and shall be measured by switching the input signal for each gray to gray.

FIG. 9 Response time

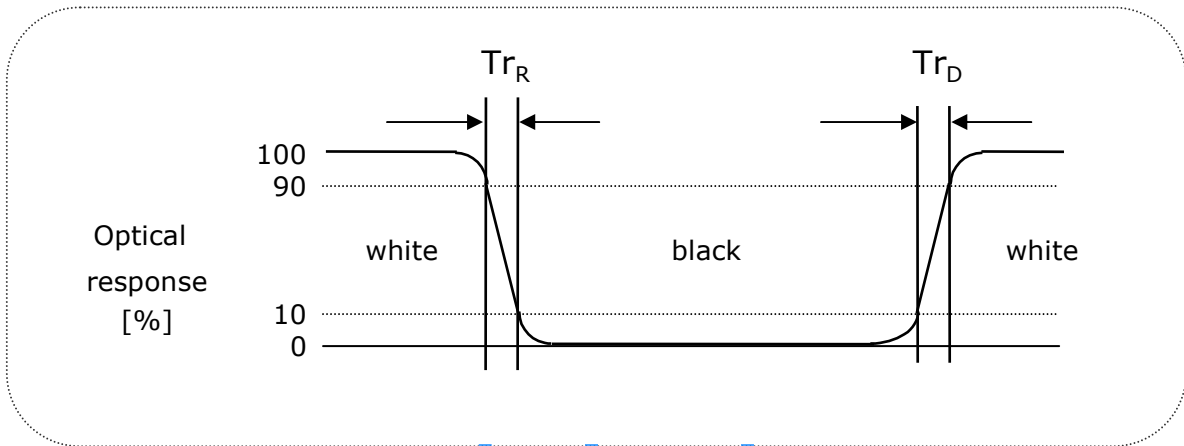

www.jxlcd.com

- Viewing angle is the angle at which the contrast ratio is greater than 10 or 5. The angles are determined for the horizontal or x axis and the vertical or y axis with respect to the z axis which is normal to the LCD surface. For more information see FIG. 10 .

FIG. 10 Viewing angle

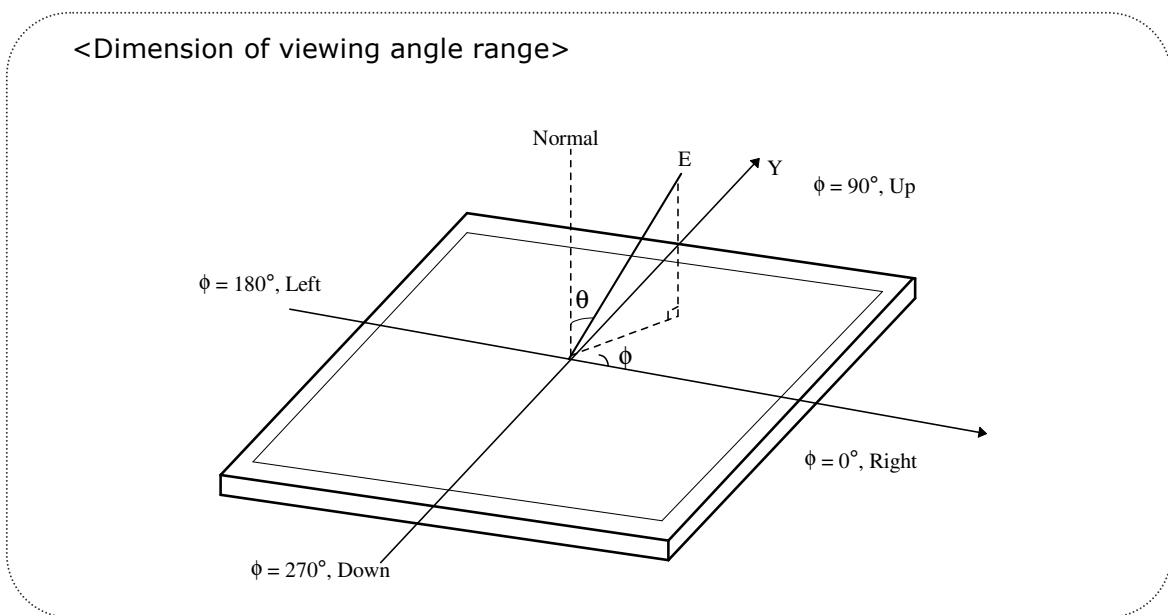

Product Specification

Notes :

6. Gray scale specification

Table 11. Gray scale

Gray level	Luminance [%] (Typ)
L0	0.1
L31	1.23
L63	4.98
L95	12.30
L127	23.58
L159	40.03
L191	61.30
L223	84.03
L255	100

7. The equation of crosstalk : $(|L_{A[or C]2} - L_{A[or C]1}| / L_{A[or C]1}) \times 100(\%)$ [Vertical]
 $(|L_{B[or D]2} - L_{B[or D]1}| / L_{B[or D]1}) \times 100(\%)$ [Horizontal]

FIG. 11 Crosstalk

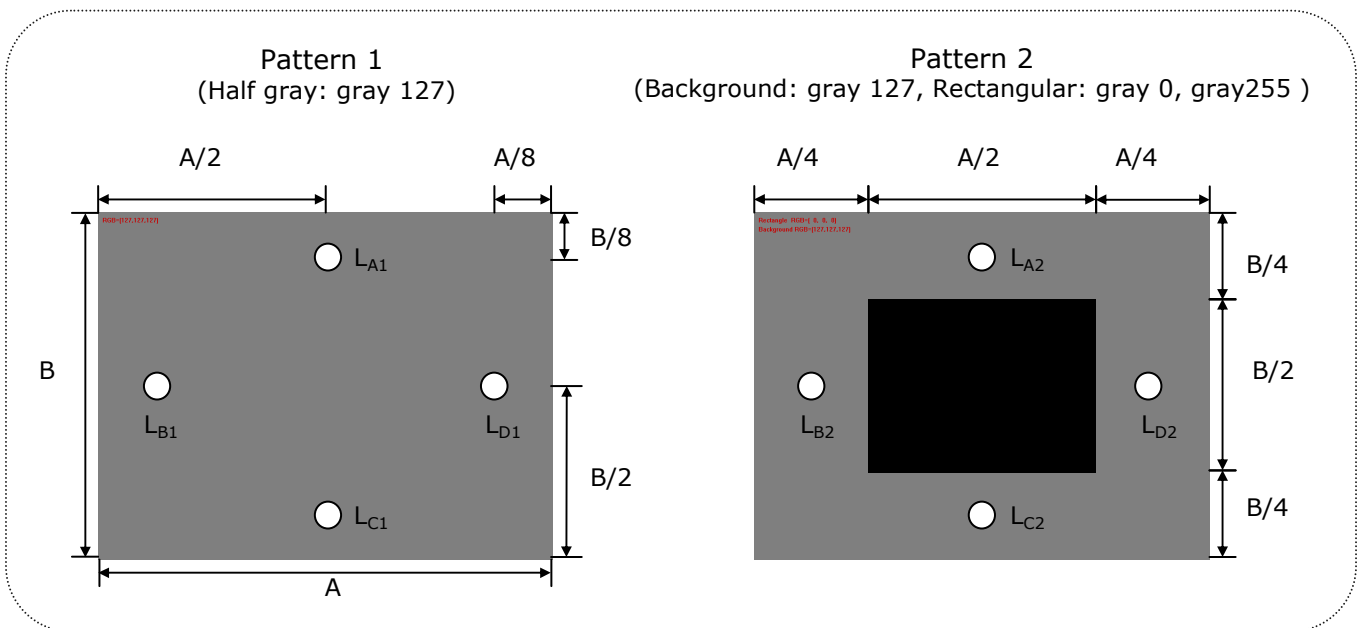

Product Specification

5. Mechanical characteristics

The contents provide general mechanical characteristics. In addition the figures in the next page are detailed mechanical drawing of the LCD.

Table 12. Mechanical characteristics

Outline dimension	Horizontal	533.2mm
	Vertical	312.0mm
	Depth	16.5 mm
Bezel area	Horizontal	513.784mm
	Vertical	291.016mm
Active display area	Horizontal	509.184mm
	Vertical	286.416mm
Weight	2,600g (Typ.) 2,750 (Max.)	
Surface treatment	Hard coating(3H) Anti-glare treatment of the front polarizer	

Notes : Please refer to a mechanic drawing in terms of tolerance at the next page.

www.jxlcd.com

Product Specification

< FRONT VIEW >

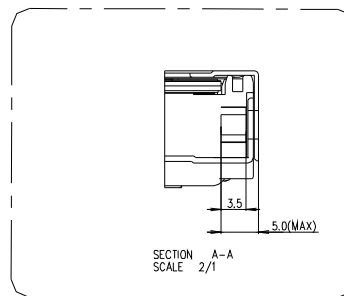
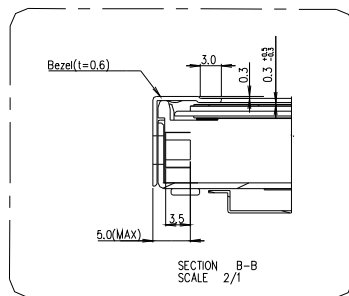
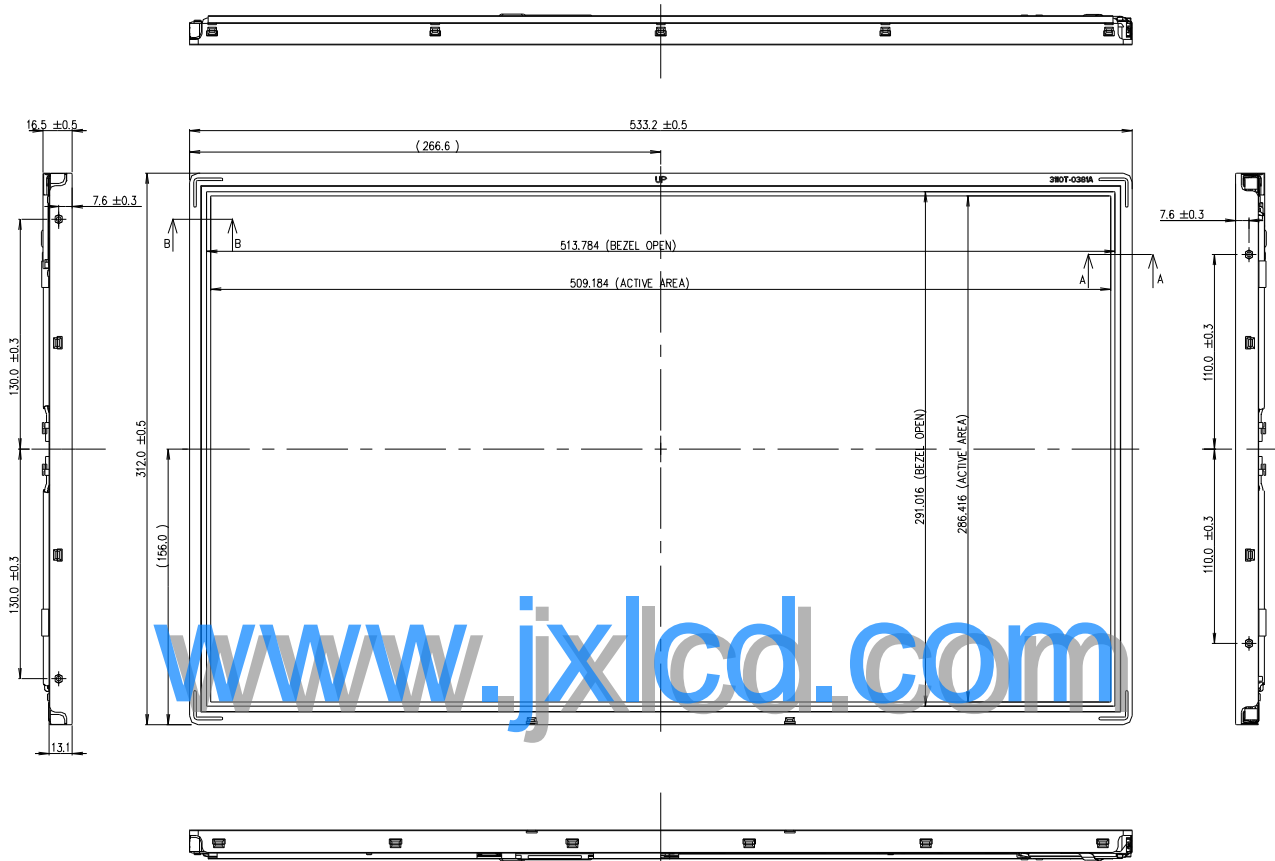

Product Specification

< REAR VIEW >

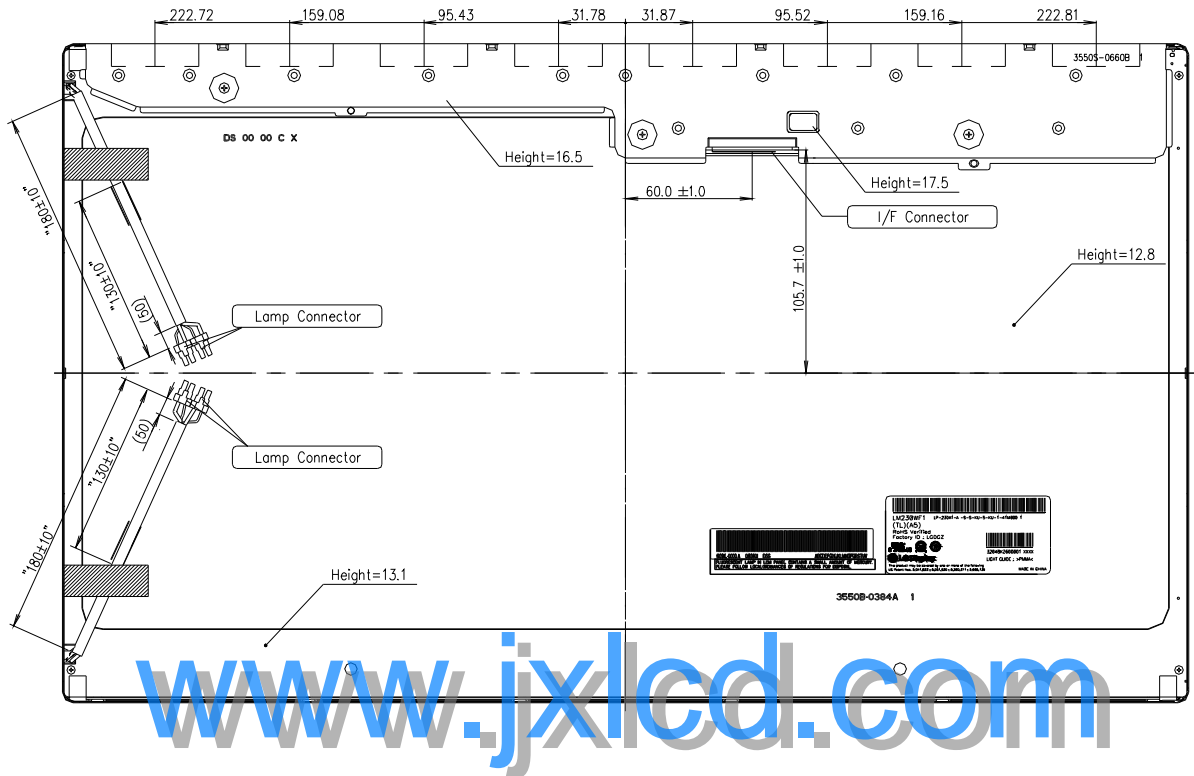

Notes

1. Backlight : 4 Cold Cathode Fluorescent Lamps.
2. I/F Connector Specification : GT103-30S-H23 or IS100-L30B-C23
3. Torque of user hole : 3.0~3.5 kgf-cm
4. Tilt and partial disposition tolerance of display area as following
 - (1) Y-Direction : IA-BI ≤ 1.4
 - (2) X-Direction : IC-DI ≤ 1.4

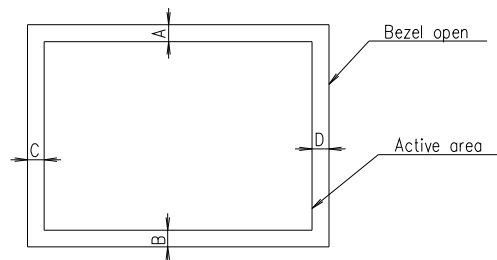

5. Lamp(CCFL) No. is marked at back light connector
6. Do not wind conductive tape around the backlight wires
7. Gap between Bezel and Panel : Max 0.8mm
8. Unspecified tolerances to be ± 0.5mm

Product Specification
6. Reliability
Table 13. Environment test conditions

No	Test Item	Condition
1	High temperature storage test	Ta= 60°C 240hrs
2	Low temperature storage test	Ta= -20°C 240hrs
3	High temperature operation test	Ta= 50°C 50%RH 240hrs
4	Low temperature operation test	Ta= 0°C 240hrs
5	Vibration test (non-operating)	Wave form : random Vibration level : 1.0GRMS Bandwidth : 10-300Hz Duration : X,Y,Z, 10 min One time each direction
6	Shock test (non-operating)	Shock level : 100G Waveform : half sine wave, 2msec Direction : ± X, ± Y, ± Z One time each direction
7	Altitude operating storage / shipment	0 - 10,000 feet(3,048m) 0 - 40,000 feet(12,192m)

{ Result evaluation criteria }

There should be no change which might affect the practical display function when the display quality test is conducted under normal operating condition.

Product Specification**7. International standards****7-1. Safety**

- a) UL 60950-1:2003, First Edition, Underwriters Laboratories, Inc.,
Standard for Safety of Information Technology Equipment.
- b) CAN/CSA C22.2, No. 60950-1-03 1st Ed. April 1, 2003, Canadian Standards Association,
Standard for Safety of Information Technology Equipment.
- c) EN 60950-1:2001, First Edition,
European Committee for Electro-technical Standardization(CENELEC)
European Standard for Safety of Information Technology Equipment.
- d) RoHS, Directive 2002/95/EC of the European Parliament and of the council of 27
January 2003

7-2. EMC

- a) ANSI C63.4 "Methods of Measurement of Radio-Noise Emissions from Low-Voltage
Electrical and Electrical Equipment in the Range of 9kHz to 40GHz. "American National
Standards Institute(ANSI),1992
- b) C.I.S.P.R "Limits and Methods of Measurement of Radio Interface Characteristics of
Information Technology Equipment." International Special Committee on Radio
Interference.
- c) EN 55022 "Limits and Methods of Measurement of Radio Interface Characteristics of
Information Technology Equipment." European Committee for Electro-technical
Standardization.(CENELEC), 1998 (Including A1: 2000)

Product Specification

8. Packing

8-1. Designation of lot mark

a) Lot mark

A	B	C	D	E	F	G	H	I	J	K	L	M
---	---	---	---	---	---	---	---	---	---	---	---	---

A,B,C : Size (Inch)
E : Month

D : Year
F ~ M : Serial No.

Note:

1. Year

Year	2001	2002	2003	2004	2005	2006	2007	2008	2009	2010
Mark	1	2	3	4	5	6	7	8	9	0

2. Month

Month	Jan	Feb	Mar	Apr	May	Jun	Jul	Aug	Sep	Oct	Nov	Dec
Mark	1	2	3	4	5	6	7	8	9	A	B	C

b) Location of lot mark

Serial No. is printed on the label. The label is attached to the backside of the LCD module. This is subject to change without prior notice.

8-2. Packing form

a) Package quantity in one box : 7pcs

b) Box size : 424mm X 328mm X 603mm

Product Specification**9. Precautions**

Please pay attention to the followings when you use this TFT LCD module.

9-1. Mounting Precautions

- (1) You must mount a module using holes arranged in four corners or four sides.
- (2) You should consider the mounting structure so that uneven force (ex. Twisted stress) is not applied to the Module. And the case on which a module is mounted should have sufficient strength so that external force is not transmitted directly to the module.
- (3) Please attach the surface transparent protective plate to the surface in order to protect the polarizer. Transparent protective plate should have sufficient strength in order to resist external force.
- (4) You should adopt radiation structure to satisfy the temperature specification.
- (5) Acetic acid type and chlorine type materials for the cover case are not desirable because the former generates corrosive gas of attacking the polarizer at high temperature and the latter causes circuit break by electro-chemical reaction.
- (6) Do not touch, push or rub the exposed polarizers with glass, tweezers or anything harder than HB pencil lead. And please do not rub with dust clothes with chemical treatment. Do not touch the surface of polarizer for bare hand or greasy cloth. (Some cosmetics are detrimental to the polarizer.)
- (7) When the surface becomes dusty, please wipe gently with absorbent cotton or other soft materials like chamois soaks with petroleum benzene. Normal-hexane is recommended for cleaning the adhesives used to attach front / rear polarizers. Do not use acetone, toluene and alcohol because they cause chemical damage to the polarizer.
- (8) Wipe off saliva or water drops as soon as possible. Their long time contact with polarizer causes deformations and color fading.
- (9) Do not open the case because inside circuits do not have sufficient strength.

9-2. Operating precautions

- (1) The spike noise causes the mis-operation of circuits. It should be lower than following voltage : $V = \pm 200\text{mV}$ (Over and under shoot voltage)
- (2) Response time depends on the temperature. (In lower temperature, it becomes longer.)
- (3) Brightness depends on the temperature. (In lower temperature, it becomes lower.) And in lower temperature, response time (required time that brightness is stable after turned on) becomes longer.
- (4) Be careful for condensation at sudden temperature change. Condensation makes damage to polarizer or electrical contacted parts. And after fading condensation, smear or spot will occur.
- (5) When fixed patterns are displayed for a long time, remnant image is likely to occur.
- (6) Module has high frequency circuits. Sufficient suppression to the electromagnetic interference shall be done by system manufacturers. Grounding and shielding methods may be important to minimized the interference.
- (7) Please do not give any mechanical and/or acoustical impact to LCM. Otherwise, LCM can not be operated its full characteristics perfectly.
- (8) A screw which is fastened up the steels should be a machine screw (if not, it causes metal foreign material and deal LCM a fatal blow)
- (9) Please do not set LCD on its edge.

Product Specification**9-3. Electrostatic discharge control**

Since a module is composed of electronic circuits, it is not strong to electrostatic discharge. Make certain that treatment persons are connected to ground through wrist band etc. And don't touch interface pin directly.

9-4. Precautions for strong light exposure

Strong light exposure causes degradation of polarizer and color filter.

9-5. Storage

When storing modules as spares for a long time, the following precautions are necessary.

- (1) Store them in a dark place. Do not expose the module to sunlight or fluorescent light. Keep the temperature between 5°C and 35°C at normal humidity.
- (2) The polarizer surface should not come in contact with any other object.
It is recommended that they be stored in the container in which they were shipped.

9-6. Handling precautions for protection film

- (1) The protection film is attached to the bezel with a small masking tape.
When the protection film is peeled off, static electricity is generated between the film and polarizer. This should be peeled off slowly and carefully by people who are electrically grounded and with well ion-blown equipment or in such a condition, etc.
- (2) When the module with protection film attached is stored for a long time, sometimes there remains a very small amount of glue still on the bezel after the protection film is peeled off.
- (3) You can remove the glue easily. When the glue remains on the bezel surface or its vestige is recognized, please wipe them off with absorbent cotton waste or other soft material like chamois soaked with normal-hexane.