



深圳市拓普微科技开发有限公司
SHENZHEN TOPWAY TECHNOLOGY CO., LTD.

LM240160MCW

LCD Module User Manual

Prepared by: Lin Date: 2009-11-17	Checked by: Date:	Approved by: Date:
---	----------------------------------	-----------------------------------

Rev.	Descriptions	Release Date
0.1	New release	2009-11-17

Table of Content

1. Basic Specifications	3
1.1 Display Specifications	3
1.2 Mechanical Specifications	3
1.3 Block Diagram	3
1.4 Interface Description	4
2. Absolute Maximum Ratings	5
3. Electrical Characteristics	5
3.1 DC Characteristics	5
3.2 LED Backlight Circuit Characteristics	5
3.3 AC Characteristics	6
3.4 Reset Timing	7
4. Function Specifications	8
4.1 Adjusting the Display Contrast	8
4.2 Resetting the LCD module	8
4.3 Interfacing Setting	8
4.4 Display Pixel Map	8
4.5 Command Summary	9
4.6 Initialization Setting Example	10
5. Design and Handling Precaution	11

1. Basic Specifications

1.1 Display Specifications

- 1) LCD Display Mode : FSTN, Positive, Transmissive
- 2) Display Color : Display Data = "1" : Dark Gray (*1)
: Display Data = "0" : Light White (*2)
- 3) Driving Method : 1/160 duty, 1/14 bias
- 4) Backlight : White LED backlight

Note:

*1. Color tone may slightly change by Temperature and Driving Condition.

*2. The Color is defined as the inactive / background color

1.2 Mechanical Specifications

- 1) Outline Dimension : 93.0 x 70.0 x 10.5MAX
see attached Outline Drawing for details

1.3 Block Diagram

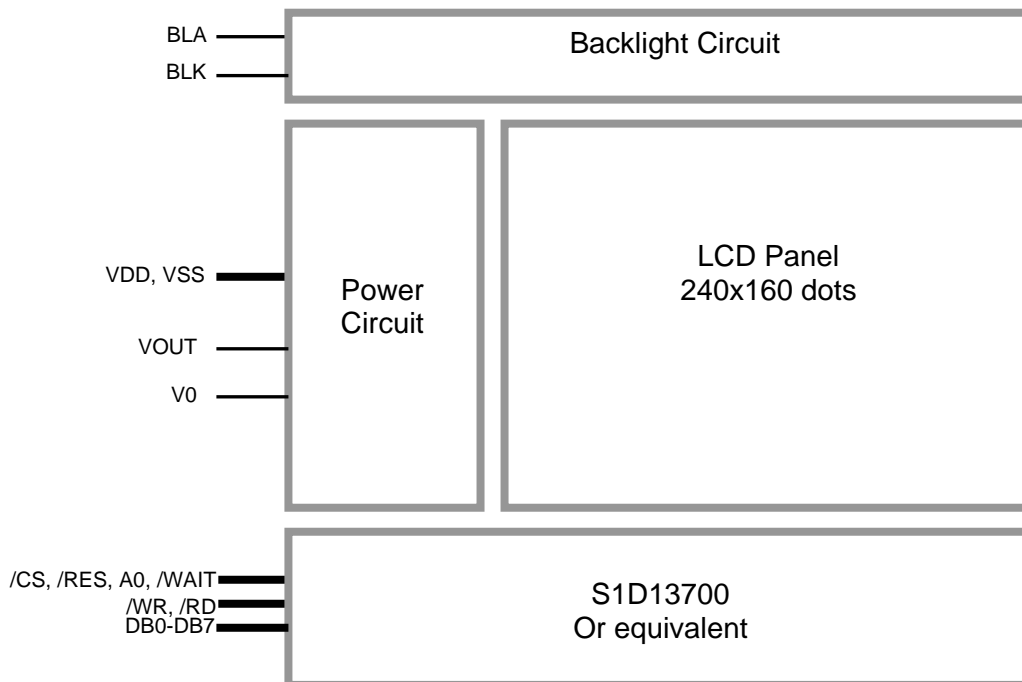

1.4 Interface Description

1.4.1 Terminal Functions

Pin No.	Pin Name	I/O	Descriptions
1	VSS	Power	0V Power Supply, GND
2	VDD	Power	Positive Power Supply
3	V0	Input	LCD Contrast Reference Input
4	/WR	Input	Write enable input, active LOW
5	/RD	Input	Read enable input, active LOW
6	/CS	Input	Chip Select Signal /CS=LOW: Data IO is enabled
7	A0	Input	Register Select A0=HIGH: data on DB0 to DB7 is display data A0=LOW: data on DB0 to DB7 is control data
8	/RES	Input	Reset Signal: /RES = L, Reset the LCD Module /RES = H, Normal Running
9	DB0	I/O	8-bit bi-directional data bus
:	:		
16	DB7		
17	/WAIT	Output	Wait signal, if there is no read write activity, /WAIT will be in HZ state
18	VOUT	Power	Power Booster Output for V0
19	BLA	Power	Positive Power Supply for LED backlight
20	BLK	Power	Negative Power Supply for LED backlight

2. Absolute Maximum Ratings

Items	Symbol	Min.	Max.	Unit	Condition
Supply Voltage	V_{DD}	0	5.5	V	$V_{SS} = 0V$
Input Voltage	V_{IN}	$V_{SS}-0.3$	$V_{DD}+0.3$	V	$V_{SS} = 0V$
Operating Temperature	T_{OP}	-20	70	°C	No Condensation
Storage Temperature	T_{ST}	-30	80	°C	No Condensation

Cautions:

Any Stresses exceeding the Absolute Maximum Ratings may cause substantial damage to the device. Functional operation of this device at other conditions beyond those listed in the specification is not implied and prolonged exposure to extreme conditions may affect device reliability.

3. Electrical Characteristics

3.1 DC Characteristics

$V_{SS}=0V, V_{DD}=5.0V, T_{OP}=25^{\circ}C$

Items	Symbol	MIN.	TYP.	MAX.	Unit	Applicable Pin
Operating Voltage	V_{DD}	4.7	5.0	5.3	V	VDD
Input High Voltage	V_{IH}	$0.8 \times V_{DD}$	-	VDD	V	Input pins
Input Low Voltage	V_{IL}	VSS	-	$0.1 \times V_{DD}$	V	Input pins
Output High Voltage	V_{OH}	$V_{DD}-0.4$	-	-	V	Output pins
Output Low Voltage	V_{OL}	-	-	$V_{SS}+0.4$	V	Output pins
Operating Current	I_{DD}	-	21	67	mA	VDD

3.2 LED Backlight Circuit Characteristics

$BLK=0V, I_{f_{BLA}}=110mA, T_{OP}=25^{\circ}C$

Items	Symbol	MIN.	TYP.	MAX.	Unit	Applicable Pin
Forward Voltage	$V_{f_{BLA}}$	-	5.0	-	V	BLA
Forward Current	$I_{f_{BLA}}$	-	110	135	mA	BLA

Cautions:

Exceeding the recommended driving current could cause substantial damage to the backlight and shorten its lifetime.

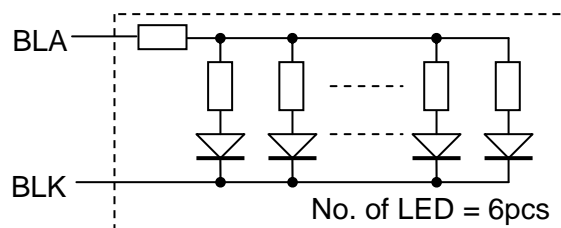

3.3 AC Characteristics

3.3.1 8080 Mode

VSS=0V, VDD=5V, T_{OP} =25°C, System clock =10MHz

Item	Symbol	MIN.	TYP.	MAX.	Unit
Address Hold Time	tah8	7	-	-	ns
Address Setup Time	tas8	7	-	-	ns
System Cycle Time	tcyc8	600	-	-	ns
Strobe Pulse Width	tcc8	500	-	-	ns
Data Setup Time	tds8	200	-	-	ns
Data Hold Time	tdh8	10	-	-	ns
Data Access Time	tacc8	5	-	-	ns
Output disable Time	toh8	3	-	15	ns

Note:

- *1. Input signal rise/fall time should be less than 20ns
- *2. Please see the S1D13700 data sheet for details

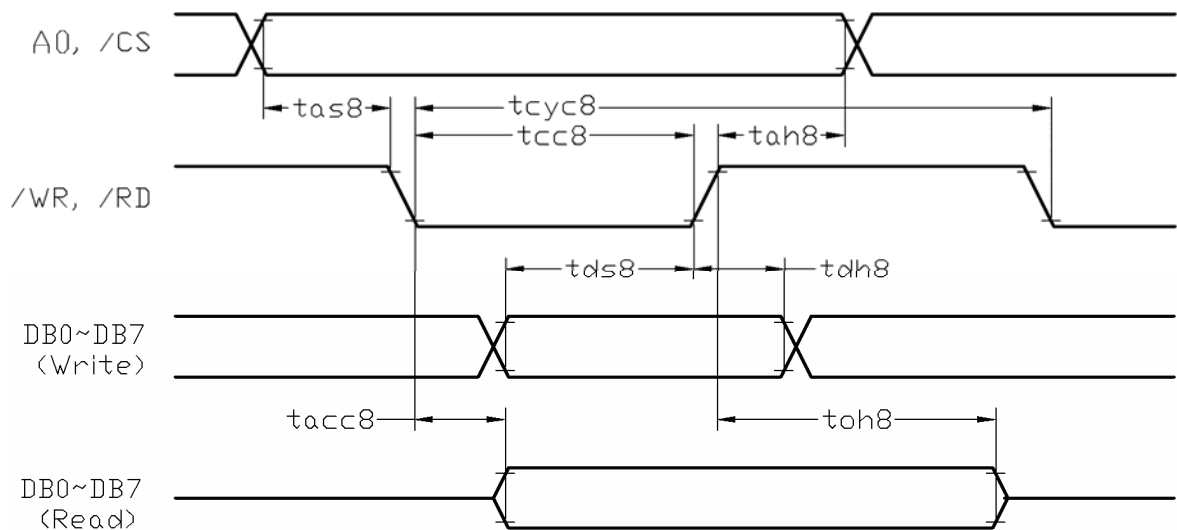

3.3.2 6800 Mode

V_{SS}=0V, V_{DD}=5V, T_{OP} =25°C, System clock =10MHz

Item	Symbol	MIN.	TYP.	MAX.	Unit
System Cycle Time	t _{cyc6}	600	-	-	ns
Address Setup Time	t _{aw6}	12	-	-	ns
Address Hold Time	t _{ah6}	10	-	-	ns
Data Setup Time	t _{ds6}	200	-	-	ns
Data Hold Time	t _{dh6}	5	-	-	ns
Output disable Time	t _{oh6}	10	-	15	ns
Data Access Time	t _{acc6}	5	-	-	ns
Enable Pulse Width	t _{ew6}	500	-	-	ns

Note:

- *1. Input signal rise/fall time should be less than 20ns
- *2. Please see the S1D13700 data sheet for details

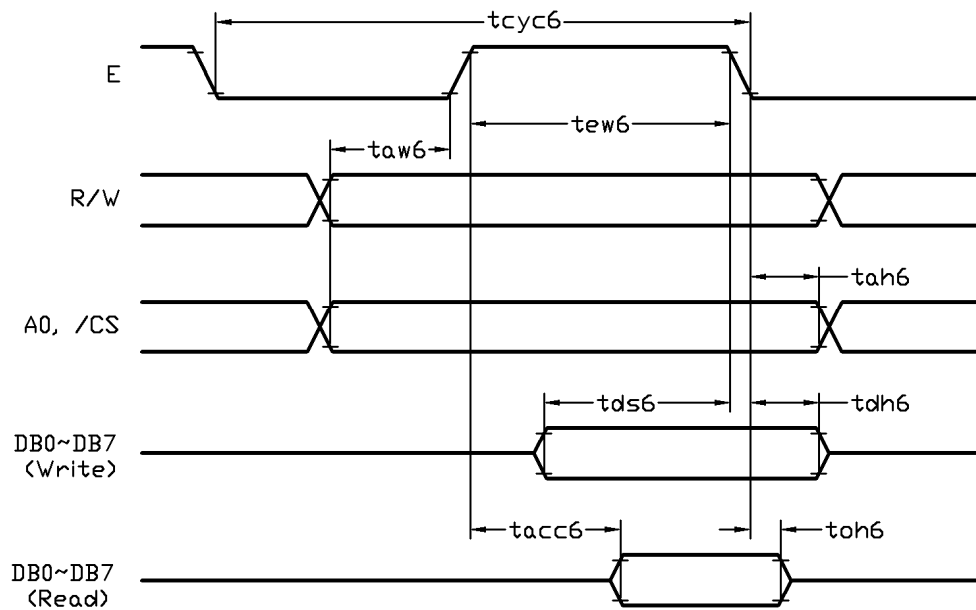

3.4 Reset Timing

V_{SS}=0V, V_{DD}=5.0V, T_{OP}=25°C

Item	Symbol	MIN.	TYP.	MAX.	Unit
Reset Plus	t _{res}	1.0	-	-	ms

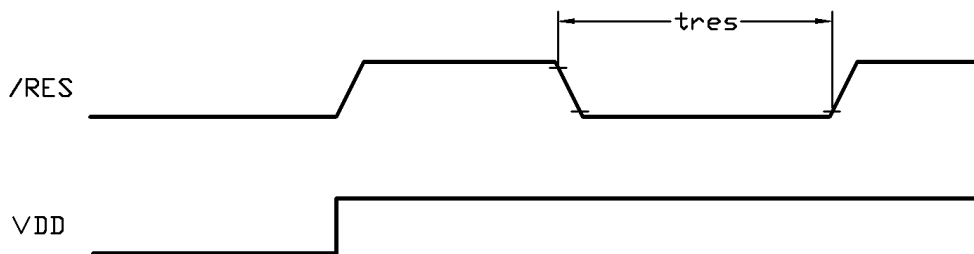

4. Function Specifications

4.1 Adjusting the Display Contrast

A Variable-Resistor must be connected to the LCD module for providing a reference to V0. Adjusting the VR will result the change of LCD display contrast. The recommended value of VR is 25k to 50k

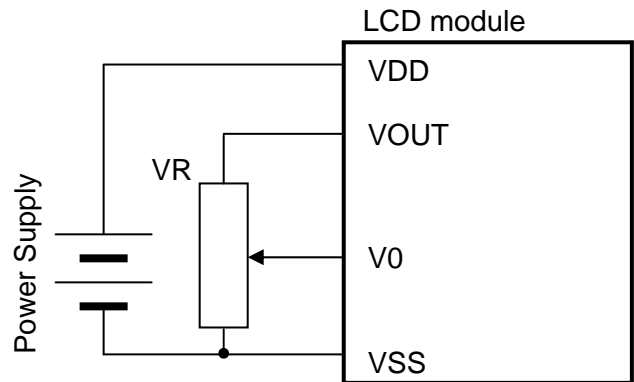

4.2 Resetting the LCD module

The LCD module should be initialized by hardware reset, using /RES terminal.

4.3 Interfacing Setting

Jumpers could be used to change bus interfacing family

Jumper		Function Discription
JP7	JP8	
close	open	6800 mode selected
open	close	8080 mode selected<default>

4.4 Display Pixel Map

1,1 (D7)	2,1 (D6)	3,1 (D5)	4,1 (D4)	5,1 (D3)	---	---	236,1 (D4)	237,1 (D3)	238,1 (D2)	239,1 (D1)	240,1 (D0)
1,2 (D7)	2,2 (D6)	3,2 (D5)	4,2 (D4)	5,2 (D3)	---	---	236,2 (D4)	237,2 (D3)	238,2 (D2)	239,2 (D1)	240,2 (D0)
1,3 (D7)	2,3 (D6)	3,3 (D5)	4,3 (D4)	5,3 (D3)	---	---	236,3 (D4)	237,3 (D3)	238,3 (D2)	239,3 (D1)	240,3 (D0)
:	:	:	:	:	:	:	:	:	:	:	:
1,158 (D7)	2,158 (D6)	3,158 (D5)	4,158 (D4)	5,158 (D3)	---	---	236,158 (D4)	237,158 (D3)	238,158 (D2)	239,158 (D1)	240,158 (D0)
1,159 (D7)	2,159 (D6)	3,159 (D5)	4,159 (D4)	5,159 (D3)	---	---	236,159 (D4)	237,159 (D3)	238,159 (D2)	239,159 (D1)	240,159 (D0)
1,160 (D7)	2,160 (D6)	3,160 (D5)	4,160 (D4)	5,160 (D3)	---	---	236,160 (D4)	237,160 (D3)	238,160 (D2)	239,160 (D1)	240,160 (D0)

- *1. Based on the top view of the LCD module, the 1, 1 (x, y) pixel is the upper-left pixel; the 240, 160 (x, y) pixel is the lower-right pixel.
- *2. For the details of memory mapping please refer to S1D13700 datasheet.

4.5 Command Summary

Command	Parameter	A0	/RD	/WR	D7	D6	D5	D4	D3	D2	D1	D0	HEX	Descriptions
SYSTEM SET	-	1	1	0	0	1	0	0	0	0	0	0	40	Init device and display (with 8 parameters)
	P1	0	1	0	0	0	IV	1	W/S	M2	M1	M0	**	M0=0: internal CG ROM M0=1: external CG ROM M1=0: no D6 correction M1=1: D6 correction M2=0: 8-pixel char height M2=1: 16-pixel char height W/S=0: single panel drive W/S=1: dual panel drive IV=0: Screen top-line correction IV=1: No screen top-line correction
	P2	0	1	0	WF	0	0	0	0		FX		**	FX: define the horizontal char size WF=0: 16-line AC drive WF=1: two frame AC drive
	P3	0	1	0	0	0	0	0			FY		**	FY: Vertical Char Size
	P4	0	1	0					C/R				**	C/R: display line address range
	P5	0	1	0					TC/R				**	TC/R: Line length selection
	P6	0	1	0					L/F				**	L/F: Frame Height selection
	P7	0	1	0					APL				**	APL: Horizontal address range (low byte)
	P8	0	1	0					APH				**	APH: Horizontal address range (high byte)
SLEEP IN	-	1	1	0	0	1	0	1	0	0	1	1	53	Enter standby mode
DISP ON/OFF	-	1	1	0	0	1	0	1	1	0	0	D	58 / 59	Enable and disable display and display flashing (with 1 parameter)
	P1	0	1	0	FP5	FP4	FP3	FP2	FP1	FP0	FC1	FC0	**	Each pair of bit in FP sets the attributes of one screen block
SCROLL	-	1	1	0	0	1	0	0	0	1	0	0	44	Set display start address and display regions (with 8 or 10 parameters)
	P1	0	1	0	A7	A6	A5	A4	A3	A2	A1	A0	**	SAD 1L
	P2	0	1	0	A15	A14	A13	A12	A11	A10	A9	A8	**	SAD 1H
	P3	0	1	0	L7	L6	L5	L4	L3	L2	L1	L0	**	SL1
	P4	0	1	0	A7	A6	A5	A4	A3	A2	A1	A0	**	SAD 2L
	P5	0	1	0	A15	A14	A13	A12	A11	A10	A9	A8	**	SAD 2H
	P6	0	1	0	L7	L6	L5	L4	L3	L2	L1	L0	**	SL2
	P7	0	1	0	A7	A6	A5	A4	A3	A2	A1	A0	**	SAD3L
	P8	0	1	0	A15	A14	A13	A12	A11	A10	A9	A8	**	SAD3H
	P9	0	1	0	A7	A6	A5	A4	A3	A2	A1	A0	**	SAD4L (for both two-screen drive and two layer config are select)
P10	0	1	0	A15	A14	A13	A12	A11	A10	A9	A8	**	SAD4H (for both two-screen drive and two layer config are select)	
CSRFORM	-	1	1	0	0	1	0	1	1	1	0	1	5D	Set cursor type (with 2 parameters)
	P1	0	1	0	0	0	0	0	X3	X2	X1	X0	**	CRX
	P2	0	1	0	CM	0	0	0	Y3	Y2	Y1	Y0	**	CRY CM=0: underscore cursor; CM=1: block cursor
CGRAM ADR	-	1	1	0	0	1	0	1	1	1	0	0	5C	Set Start address of char generator RAM (with 2 parameters)
	P1	0	1	0	A7	A6	A5	A4	A3	A2	A1	A0	**	SAGL
	P2	0	1	0	A15	A14	A13	A12	A11	A10	A9	A8	**	SAGH
CSRDIR	-	1	1	0	0	1	0	0	1	1	CD1	CD0	4C-4F	Set Direction of Cursor movement
HDOT SCR	-	1	1	0	0	1	0	1	1	0	1	0	5A	Set horizontal scroll position (with 1 parameters)
	P1	0	1	0	0	0	0	0	0	D2	D1	D0	**	
OVLAY	-	1	1	0	0	1	0	1	1	0	1	1	5B	Set display overlay format (with 1 parameters)
	P1	0	1	0	0	0	0	OV	DM2	DM1	MX1	MX0	**	
CSRW	-	1	1	0	0	1	0	0	0	1	1	0	46	Set cursor address (with 2 parameters)
	P1	0	1	0	A7	A6	A5	A4	A3	A2	A1	A0	**	CSRL
	P2	0	1	0	A15	A14	A13	A12	A11	A10	A9	A8	**	CSRH
CSRRL	-	1	1	0	0	1	0	0	0	1	1	1	47	Read Cursor Address (with 2 parameters)
	P1	1	0	1	A7	A6	A5	A4	A3	A2	A1	A0	**	CSRL
	P2	1	0	1	A15	A14	A13	A12	A11	A10	A9	A8	**	CSRH
MWRITE	-	1	1	0	0	1	0	0	0	0	1	0	42	Write to display memory (with n parameters)
	P1	0	1	0									**	Display memory data
	:	:	:										**	
	Pn	0	1	0									**	
MREAD	-	1	1	0	0	1	0	0	0	0	1	1	43	Read from display memory (with n parameters)
	P1	1	0	1									**	Display memory data
	:	:	:										**	
	Pn	1	0	1									**	

4.6 Initialization Setting Example

Command	Parameter	A0	/RD	/WR	Value (binary)	HEX	Descriptions
SYSTEM SET	-	1	1	0	0100 0000	40	Init device and display, (with 8 parameters)
	P1	0	1	0	0011 0000	30	M0=0: internal CG ROM M0=1: external CG ROM M1=0: no D6 correction M1=1: D6 correction M2=0: 8-pixel char height M2=1: 16-pixel char height W/S=0: single panel drive W/S=1: dual panel drive IV=0: Screen top-line correction IV=1: No screen top-line correction
	P2	0	1	0	1000 0111	87	FX: define the horizontal char size WF=0: 16-line AC drive WF=1: two frame AC drive
	P3	0	1	0	0000 0000	00	FY: Vertical Char Size
	P4	0	1	0	0001 1110	1E	C/R: display line address range
	P5	0	1	0	0110 1000	68	TC/R: Line length selection
	P6	0	1	0	1001 1111	9F	L/F: Frame Height selection
	P7	0	1	0	0001 1110	1E	APL: Horizontal address range (low byte)
	P8	0	1	0	0000 0000	00	APH: Horizontal address range (high byte)
DISP ON/OFF	-	1	1	0	0101 1001	59	Enable
	P1	0	1	0	0000 0100	04	
SCROLL	-	1	1	0	0100 0100	44	Set cursor type (with 10 parameters)
	P1	0	1	0	0000 0000	00	SAD 1L
	P2	0	1	0	0000 0000	00	SAD 1H
	P3	0	1	0	1001 1111	9F	SL1
	P4	0	1	0	0000 0000	00	SAD 2L
	P5	0	1	0	0000 0000	00	SAD 2H
	P6	0	1	0	1001 1111	9F	SL2
	P7	0	1	0	0000 0000	00	SAD3L
	P8	0	1	0	0000 0000	00	SAD3H
CSRDIR	-	1	1	0	0100 1100	4C	Set Direction of Cursor movement
HDOT SCR	-	1	1	0	0101 1010	5A	Set horizontal scroll position (with 1 parameters)
	P1	0	1	0	0000 0000	00	
OVLAY	-	1	1	0	0101 1011	5B	Set display overlay format (with 1 parameters)
	P1	0	1	0	0000 1101	0D	
CSRW	-	1	1	0	0100 0110	46	Set cursor address (with 2 parameters)
	P1	0	1	0	0000 0000	00	CSRL
	P2	0	1	0	0000 0000	00	CSRH
MWRITE	-	1	1	0	0100 0010	42	Write to display memory (with n parameters)
	P1	0	1	0	Memory Data	**	Display memory data
	:	:	:	:	:	**	
	Pn	0	1	0	Memory Data	**	

5. Design and Handling Precaution

1. The LCD panel is made by glass. Any mechanical shock (eg. dropping from high place) will damage the LCD module.
2. Do not add excessive force on the surface of the display, which may cause the Display color change abnormally.
3. The polarizer on the LCD is easily get scratched. If possible, do not remove the LCD protective film until the last step of installation.
4. Never attempt to disassemble or rework the LCD module.
5. Only Clean the LCD with Isopropyl Alcohol or Ethyl Alcohol. Other solvents (eg. water) may damage the LCD.
6. When mounting the LCD module, make sure that it is free from twisting, warping and distortion.
7. Ensure to provide enough space (with cushion) between case and LCD panel to prevent external force adding on it, or it may cause damage to the LCD or degrade the display result.
8. Only hold the LCD module by its side. Never hold LCD module by add force on the heat seal or TAB.
9. Never add force to component of the LCD module. It may cause invisible damage or degrade of the reliability.
10. LCD module could be easily damaged by static electricity. Be careful to maintain an optimum anti-static work environment to protect the LCD module.
11. When peeling off the protective film from LCD, static charge may cause abnormal display pattern. It is normal and will resume to normal in a short while.
12. Take care and prevent get hurt by the LCD panel sharp edge.
13. Never operate the LCD module exceed the absolute maximum ratings.
14. Keep the signal line as short as possible to prevent noisy signal applying to LCD module.
15. Never apply signal to the LCD module without power supply.
16. IC chip (eg. TAB or COG) is sensitive to the light. Strong lighting environment could possibly cause malfunction. Light sealing structure casing is recommend.
17. LCD module reliability may be reduced by temperature shock.
18. When storing the LCD module, avoid exposure to the direct sunlight, high humidity, high temperature or low temperature. They may damage or degrade the LCD module