



深圳市拓普微科技开发有限公司

SHENZHEN TOPWAY TECHNOLOGY CO., LTD.

LM24080BCW-3

LCD Module User Manual

Prepared by: Liuweilin Date: 2012-04-07	Checked by: Date:	Approved by: Date:
--	----------------------------------	-----------------------------------

Rev.	Descriptions	Release Date
0.1	New release	2010-04-01
0.2	Revise Backlight power supply on 3.2 LED Backlight Circuit	2010-04-16
0.3	Update Interfacing Setting	2012-04-07

Table of Content

1. Basic Specifications	3
1.1 Display Specifications	3
1.2 Mechanical Specifications	3
1.3 Block Diagram	3
1.4 Terminal Functions	4
2. Absolute Maximum Ratings	5
3. Electrical Characteristics	5
3.1 DC Characteristics	5
3.2 LED Backlight Circuit Characteristics	5
3.3 AC Characteristics	6
3.4 Reset Timing	6
4. Function Specifications	7
4.1 Resetting the LCD module	7
4.2 Interfacing Setting	7
4.3 Display Pixel Map(example)	7
4.4 Control Data and Command	8
4.5 Command Summary	8
5. Design and Handling Precaution	9

1. Basic Specifications

1.1 Display Specifications

- 1) LCD Display Mode : FSTN, Positive, Transflective
- 2) Display Color : Display Data = "1" : Dark Gray (*1)
: Display Data = "0" : Light Gray (*2)
- 3) Viewing Angle : 6H
- 4) Driving Method : 1/80 duty, 1/10 bias
- 5) Backlight : White LED backlight

Note:

*1. Color tone may slightly change by Temperature and Driving Condition.

*2. The Color is defined as the inactive / background color

1.2 Mechanical Specifications

- 1) Outline Dimension : 130.0 x 65.0 x 11.5 MAX.(Exclude FFC Terminal)
see attached Outline Drawing for details

1.3 Block Diagram

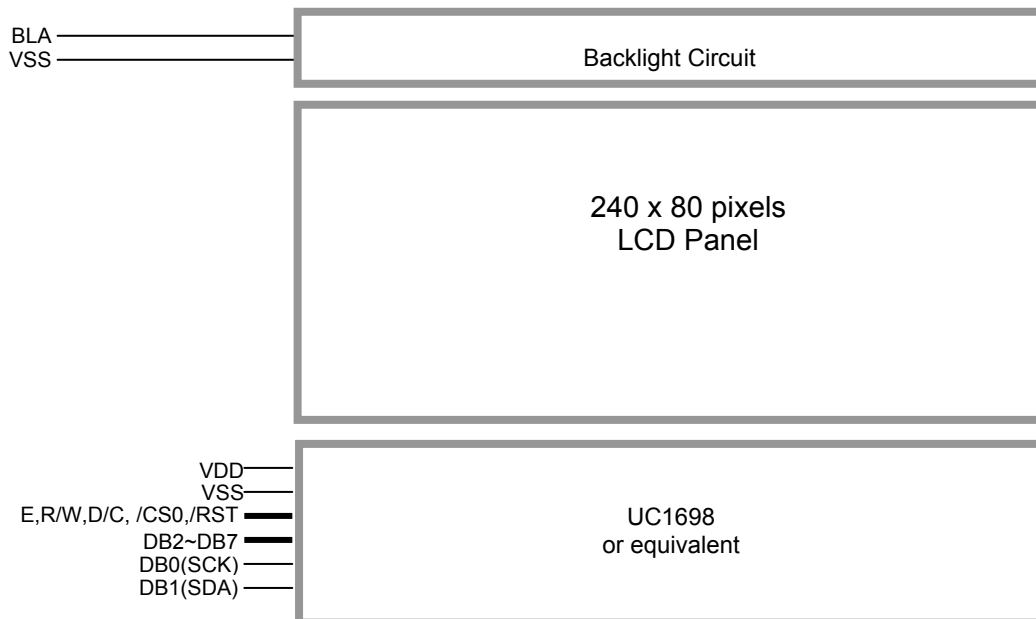

1.4 Terminal Functions

Pin No.	Pin Name	I/O	Descriptions			
			Display			
			8-bit parallel 68mode	8-bit parallel 80mode	Serial	
					4wire	3wire
1	VSS	Power	0V Power Supply, GND			
2	VDD	Power	Positive Power Supply			
3	NC	-	No connection,leave open			
4	D/C	Input	Register Select D/C=HIGH: data on DB0 to DB7 is display data D/C=LOW: data on DB0 to DB7 is command data		pull down	
5	R/W	Input	In read mode R/W = H; Data read form LCD module, data appears at DB0 – DB7 and can be read by the host while, E = H and the device is being selected In write mode R/W = L; Data write to the LCD module, data appears at DB0 – DB7 will be written into the LCD module at E = H→L and device is being selected	Write enable input, active LOW	pull down	
6	E	Input		Read enable input, active LOW		
7	DB0	IO	8-bit bi-directional data bus		Serial clock input	
8	DB1				Serial data input	
9	DB2				pull up or pull down	
10	DB3					
11	DB4					
:	:					
14	DB7					
15	/CS0	Input	Chip Select Signal /CS0=L: Data IO is enabled			
16	/RST	Input	Reset Signal: /RST = L, Reset the LCD Module /RST = H, Normal Running			
17	NC	-	No connection,leave open			
18	NC	-	No connection,leave open			
19	NC	-	No connection,leave open			
20	BLA	Power	Positive Power Supply for LED backlight			

note:

- *1. The LCM Fixed to 68 mode by default ,could been changed to serial and 80 mode by changing jumpers

2. Absolute Maximum Ratings

Items	Symbol	Min.	Max.	Unit	Condition
Supply Voltage	V_{DD}	-0.3	+3.6	V	$V_{SS} = 0V$
Input Voltage	V_{IN}	-0.3	$V_{DD}+0.3$	V	$V_{SS} = 0V$
Operating Temperature	T_{OP}	-20	+70	°C	No Condensation
Storage Temperature	T_{ST}	-30	+80	°C	No Condensation

Cautions:

Any Stresses exceeding the Absolute Maximum Ratings may cause substantial damage to the device. Functional operation of this device at other conditions beyond those listed in the specification is not implied and prolonged exposure to extreme conditions may affect device reliability.

3. Electrical Characteristics

3.1 DC Characteristics

$V_{SS}=0V, V_{DD}=3.0V, T_{OP}=25^{\circ}C$

Items	Symbol	MIN.	TYP.	MAX.	Unit	Applicable Pin
Operating Voltage	V_{DD}	2.7	3.0	3.3	V	VDD
Input High Voltage	V_{IN}	$0.7 \times V_{DD}$	-	VDD	V	DB0~DB7, E, R/W, /CS0, D/C, /RST,
Input Low Voltage	V_{IN}	VSS	-	$0.2 \times V_{DD}$	V	DB0~DB7, E, R/W, /CS0, D/C, /RST
Operating Current	I_{DD}	-	0.6	2.3	mA	VDD

3.2 LED Backlight Circuit Characteristics

$BLK=0V, I_{f_{BLA}}=102mA, T_{OP}=25^{\circ}C$

Items	Symbol	MIN.	TYP.	MAX.	Unit	Applicable Pin
Forward Voltage	$V_{f_{BLA}}$	-	3.3	-	V	BLA
Forward Current	$I_{f_{BLA}}$	-	102	120	mA	BLA

Cautions:

Exceeding the recommended driving current could cause substantial damage to the backlight and shorten its lifetime.

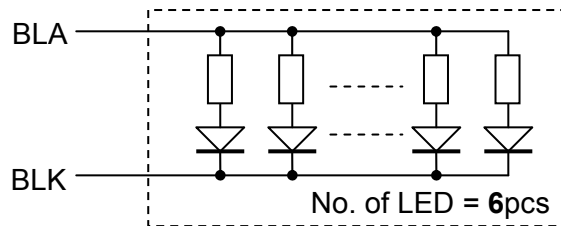

3.3 AC Characteristics

3.3.1 68 Mode

$V_{SS}=0V, V_{DD}=3.0V, T_{OP}=25^{\circ}C$

Item	Symbol	MIN.	TYP.	MAX.	Unit
Address setup time	tAS68	0	-	-	ns
Address hold time	tAH68	0	-	-	ns
System cycle time	tCY68	80	-	-	ns
Pulse width	tPWW68	50	-	-	ns
Low pulse width	tLPW68	40	-	-	ns
Data setup time	tDS68	30	-	-	ns
Data hold time	tDH68	0	-	-	ns
Chip select setup time	tCSSA68	5	-	-	ns
	tCSH68	5	-	-	ns

Note: *1. Input signal rise/fall time should be less than 20ns
For details, please refer to UC1698U datasheet.

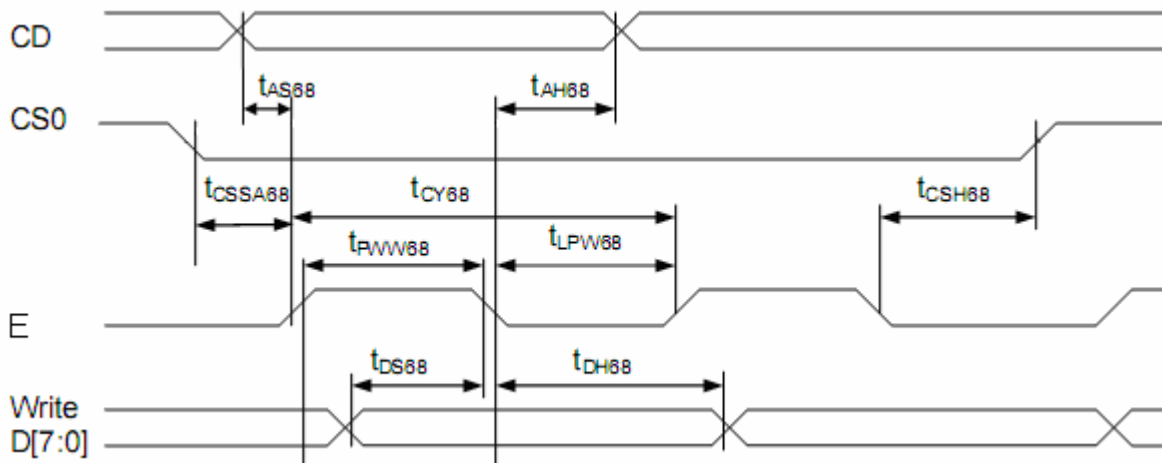

Bus Timing Diagram

3.4 Reset Timing

$V_{SS}=0V, V_{DD}=3.0V, T_{OP}=25^{\circ}C$

Item	Symbol	MIN.	TYP.	MAX.	Unit
Reset setup time	trs	1.0	-	-	ms
Reset hold time	trh	1.0	-	-	ms
Reset active time	trst	150	-	-	us

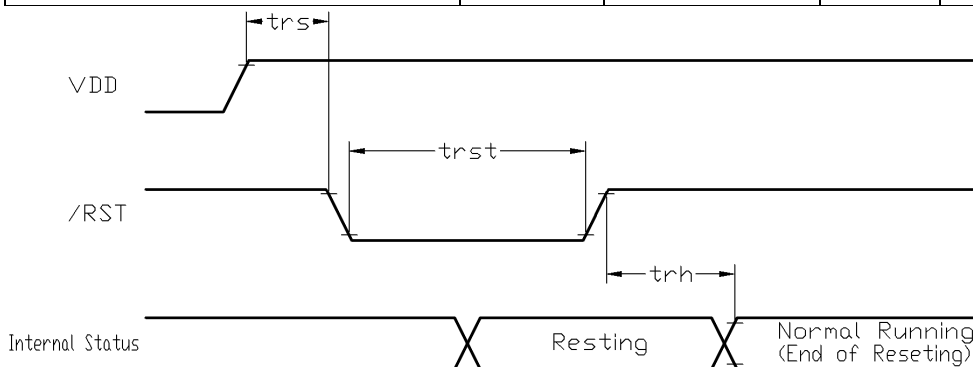

Reset Timing Diagram

4. Function Specifications

4.1 Resetting the LCD module

The LCD module should be initialized by hardware reset, using /RST terminal.

While turning on the VDD and VSS power supply, maintain /RST terminal at LOW level. After the power supply stabilized, release the reset terminal (/RST=HIGH)

4.2 Interfacing Setting

Jumpers could be used to change bus interfacing family

Jumpers						Function Discription
JP1	JP2	JP3	JP4	JP5	JP6	
open	close	close	open	close	open	68 mode 8 bit selected <default>
open	close	open	close	close	open	80 mode 8 bit selected
close	open	open	close	open	close	4wire serial *1

NOTE 1: In serial mode, the pin E must be pull down, and other unused control pins and data bus pins been connected to VDD or VSS

4.3 Display Pixel Map(example)

1,1	2,1	3,1	4,1	5,1	---	---	236,1	237,1	238,1	239,1	240,1
1,2	2,2	3,2	4,2	5,2	---	---	236,2	237,2	238,2	239,2	240,2
1,3	2,3	3,3	4,3	5,3	---	---	236,3	237,3	238,3	239,3	240,3
:	:	:	:	:	:	:	:	:	:	:	:
:	:	:	:	:	:	:	:	:	:	:	:
:	:	:	:	:	:	:	:	:	:	:	:
1,78	2,78	3,78	4,78	5,78	---	---	236,78	237,78	238,78	239,78	240,78
1,79	2,79	3,79	4,79	5,79	---	---	236,79	237,79	238,79	239,79	240,79
1,80	2,80	3,80	4,80	5,80	---	---	236,80	237,80	238,80	239,80	240,80

Pixel mapping (Top View)

Note:

*1. Based on the top view of the LCD module, the 1, 1 (x, y) pixel is the upper-left pixel; the 240, 80 (x, y) pixel is the lower-right pixel.

*2. The registet LC[7:6] is set to 01b.

*3

1,1	2,1	3,1	4,1	5,1	6,1
1st byte		2nd byte		3rd byte	

*4. Pixel[1,1]=1st byte D7~D4, Pixel[2,1]=1st byte D3~D0, Pixel[3,1]=2nd byte D7~D4, Pixel[4,1]=2nd byte D3~D0. For the details of memory mapping please refer to UC1698 datasheet.

4.4 Control Data and Command

The LCD module setting is controlled by the internal Register Values.

The Register Address should be addressed when RS=1 and Register Value should be issued when RS=0.

A full command sequence should be as follow.

Steps	E	RS	Data (DB0~ DB7)
1 st	H→L	1	Register Address
2 nd	H→L	0	Register Value

4.5 Command Summary

	Command	C/D	W/R	D7	D6	D5	D4	D3	D2	D1	D0	Action	Default	
1	Write Data Byte	1	0	#	#	#	#	#	#	#	#	Write 1 byte	N/A	
2	Read Data Byte	1	1	#	#	#	#	#	#	#	#	Read 1 byte	N/A	
3	Get Status & PM	0	1	GE	MX	MY	WA	DE	WS	MD	MS	Get {Status, Ver, PMO, Product Code, PID, MID}	N/A	
				Ver	PMO[6:0]						MID[1:0]			
4	Set Column Address LSB	0	0	0	0	0	0	#	#	#	#	Set CA[3:0]	0	
	Set Column Address MSB	0	0	0	0	0	1	0	#	#	#	Set CA[6:4]	0	
5	Set Temp. Compensation	0	0	0	0	1	0	0	1	#	#	Set TC[1:0]	0	
6	Set Power Control	0	0	0	0	1	0	1	0	#	#	Set PC[1:0]	10b	
7	Set Adv. Program Control (double-byte command)	0	0	0	0	1	1	0	0	0	R	Set APC[R][7:0], R = 0 or 1	N/A	
		0	0	#	#	#	#	#	#	#	#			
8	Set Scroll Line LSB	0	0	0	1	0	0	#	#	#	#	Set SL[3:0]	0	
	Set Scroll Line MSB	0	0	0	1	0	1	#	#	#	#	Set SL[7:4]	0	
9	Set Row Address LSB	0	0	0	1	1	0	#	#	#	#	Set RA[3:0]	0	
	Set Row Address MSB	0	0	0	1	1	1	#	#	#	#	Set RA[7:4]	0	
10	Set V _{BIAS} Potentiometer (double-byte command)	0	0	1	0	0	0	0	0	0	1	Set PM[7:0]	40H	
		0	0	#	#	#	#	#	#	#	#			
11	Set Partial Display Control	0	0	1	0	0	0	0	1	0	#	Set LC[8]	0	
12	Set RAM Address Control	0	0	1	0	0	0	1	#	#	#	Set AC[2:0]	001b	
13	Set Fixed Lines	0	0	1	0	0	1	0	0	0	0	Set {FLT, FLB}	0	
		0	0	#	#	#	#	#	#	#	#			
14	Set Line Rate	0	0	1	0	1	0	0	0	#	#	Set LC[4:3]	10b	
15	Set All-Pixel-ON	0	0	1	0	1	0	0	1	0	#	Set DC[1]	0	
16	Set Inverse Display	0	0	1	0	1	0	0	1	1	#	Set DC[0]	0	
17	Set Display Enable	0	0	1	0	1	0	1	#	#	#	Set DC[4:2]	110b	
18	Set LCD Mapping Control	0	0	1	1	0	0	0	#	#	#	Set LC[2:0]	0	
19	Set N-Line Inversion	0	0	-	-	-	#	#	#	#	#	Set NIV[4:0]	1DH	
20	Set Color Pattern	0	0	1	1	0	1	0	0	0	#	Set LC[5]	0 (BGR)	
21	Set Color Mode	0	0	1	1	0	1	0	1	#	#	Set LC[7:6]	10b	
22	Set COM Scan Function	0	0	1	1	0	1	1	#	#	#	Set CSF[2:0]	000b	
23	System Reset	0	0	1	1	1	0	0	0	1	0	System Reset	N/A	
24	NOP	0	0	1	1	1	0	0	0	1	1	No operation	N/A	
25	Set Test Control (double-byte command)	0	0	1	1	1	0	0	1	TT		For testing only. Do not use.	N/A	
		0	0	#	#	#	#	#	#	#	#			
26	Set LCD Bias Ratio	0	0	1	1	1	0	1	0	#	#	Set BR[1:0]	11b: 12	
27	Set COM End	0	0	1	1	1	1	0	0	0	1	Set CEN[6:0]	159	
		0	0	-	#	#	#	#	#	#	#			
28	Set Partial Display Start	0	0	1	1	1	1	0	0	1	0	Set DST[6:0]	0	
		0	0	-	#	#	#	#	#	#	#			
29	Set Partial Display End	0	0	1	1	1	1	0	0	1	1	Set DEN[6:0]	159	
		0	0	-	#	#	#	#	#	#	#			
30	Set Window Program Starting Column Address	0	0	1	1	1	1	0	1	0	0	Shared with MTP commands	Set WPC0	0
		0	0	-	#	#	#	#	#	#	#		Set WPP0	0
31	Set Window Program Starting Row Address	0	0	1	1	1	1	0	1	0	1	Shared with MTP commands	Set WPC1	127
		0	0	#	#	#	#	#	#	#	#		Set WPP1	159
32	Set Window Program Ending Column Address	0	0	1	1	1	1	0	1	1	0	Shared with MTP commands	Set WPC1	127
		0	0	-	#	#	#	#	#	#	#		Set WPP1	159
33	Set Window Program Ending Row Address	0	0	1	1	1	1	0	1	1	1	Shared with MTP commands	Set WPC1	127
		0	0	#	#	#	#	#	#	#	#		Set WPP1	159
34	Window Program Mode	0	0	1	1	1	1	1	0	0	#	Set AC[3]	0: Inside	
35	Set MTP Operation control	0	0	1	0	1	1	1	0	0	0	Set MTPC[4:0]	10H	
		0	0	-	-	-	#	#	#	#	#			

Note: *1.For the details, please refer to UC1698 Data sheet.

*2. C/D: 0:Control, 1:Data; W/R: 0: Write Cycle, 1:Read Cycle(Read available in 68 mode); #: Useful Data bits; - Don't Care

5. Design and Handling Precaution

1. The LCD panel is made by glass. Any mechanical shock (eg. dropping from high place) will damage the LCD module.
2. Do not add excessive force on the surface of the display, which may cause the Display color change abnormally.
3. The polarizer on the LCD is easily get scratched. If possible, do not remove the LCD protective film until the last step of installation.
4. Never attempt to disassemble or rework the LCD module.
5. Only Clean the LCD with Isopropyl Alcohol or Ethyl Alcohol. Other solvents (eg. water) may damage the LCD.
6. When mounting the LCD module, make sure that it is free from twisting, warping and distortion.
7. Ensure to provide enough space (with cushion) between case and LCD panel to prevent external force adding on it, or it may cause damage to the LCD or degrade the display result.
8. Only hold the LCD module by its side. Never hold LCD module by add force on the heat seal or TAB.
9. Never add force to component of the LCD module. It may cause invisible damage or degrade of the reliability.
10. LCD module could be easily damaged by static electricity. Be careful to maintain an optimum anti-static work environment to protect the LCD module.
11. When peeling off the protective film from LCD, static charge may cause abnormal display pattern. It is normal and will resume to normal in a short while.
12. Take care and prevent get hurt by the LCD panel sharp edge.
13. Never operate the LCD module exceed the absolute maximum ratings.
14. Keep the signal line as short as possible to prevent noisy signal applying to LCD module.
15. Never apply signal to the LCD module without power supply.
16. IC chip (eg. TAB or COG) is sensitive to the light. Strong lighting environment could possibly cause malfunction. Light sealing structure casing is recommend.
17. LCD module reliability may be reduced by temperature shock.
18. When storing the LCD module, avoid exposure to the direct sunlight, high humidity, high temperature or low temperature. They may damage or degrade the LCD module