

# SPECIFICATION FOR APPROVAL

- ( ) Preliminary Specification  
 (◆) Final Specification

Title	<b>24.0" WUXGA TFT LCD</b>
BUYER	NEC DS
MODEL	
SUPPLIER	LG Display Co., Ltd.
*MODEL	LM240WU8
SUFFIX	SLD2

\*When you obtain standard approval,  
 please use the above model name without suffix

APPROVED BY	SIGNATURE DATE
/	
/	
/	

Please return 1 copy for your confirmation with your signature and comments.

APPROVED BY	SIGNATURE DATE
B. C. KIM / G.Manager	
<b>REVIEWED BY</b>	
S. H. Kim / Manager [C]	
Y. H. Hwang / Manager [M]	
M. S. Kang / Manager [P]	
S. H. Han / Manager [O]	
<b>PREPARED BY</b>	
T. K. Kim / Engineer	

**IT/Mobile Development Division 1**  
**LG Display Co., Ltd**

**Product Specification**
**Contents**

No		ITEM	Page
		COVER	1
		CONTENTS	2
		RECORD OF REVISIONS	3
1		GENERAL DESCRIPTION	4
2		ABSOLUTE MAXIMUM RATINGS	5
3		ELECTRICAL SPECIFICATIONS	6
	1)	ELECTRICAL CHARACTERISTICS	6
	2)	INTERFACE CONNECTIONS	8
	3)	LVDS characteristics	11
	4)	SIGNAL TIMING SPECIFICATIONS	14
	5)	SIGNAL TIMING WAVEFORMS	15
	6)	COLOR INPUT DATA REFERNECE	16
	7)	POWER SEQUENCE	17
	8)	POWER DIP CONDITION	18
4		OPTICAL SPECIFICATIONS	19
5		MECHANICAL CHARACTERISTICS	25
6		RELIABILITY	28
7		INTERNATIONAL STANDARDS	29
	1)	SAFETY	29
	2)	EMC	29
	3)	ENVIRONMENT	27
8		PACKING	30
	1)	DESIGNATION OF LOT MARK	30
	2)	PACKING FORM	30
9		PRECAUTIONS	31
	1)	MOUNTING PRECAUTIONS	31
	2)	OPERATING PRECAUTIONS	31
	3)	ELECTROSTATIC DISCHARGE CONTROL	32
	4)	PRECAUTIONS FOR STRONG LIGHT EXPOSURE	32
	5)	STROAGE	32
	6)	HANDLING PRECAUTIONS FOR PROTECTION FILM	32



**Product Specification**

**1. General description**

LM240WU8 is a Color Active Matrix Liquid Crystal Display with an integral Light Emitting Diode (LED) backlight system. The matrix employs a-Si Thin Film Transistor as the active element. It is a transmissive type display operating in the normally black mode. It has a 24 inch diagonally measured active display area with WUXGA resolution (1200 vertical by 1920 horizontal pixel array). Each pixel is divided into Red, Green and Blue sub-pixels or dots which are arranged in vertical stripes. Gray scale or the brightness of the sub-pixel color is determined with a 8-bit gray scale signal for each dot, thus, presenting a palette of more than 16,7M colors with Advanced-FRC(Frame Rate Control). It has been designed to apply the interface method that enables low power, high speed, low EMI. FPD Link or compatible must be used as a LVDS(Low Voltage Differential Signaling) chip. It is intended to support applications where thin thickness, wide viewing angle, low power are critical factors and graphic displays are important. In combination with the vertical arrangement of the sub-pixels, the LM240WU8's characteristics provide an excellent flat panel display for office automation products such as monitors.

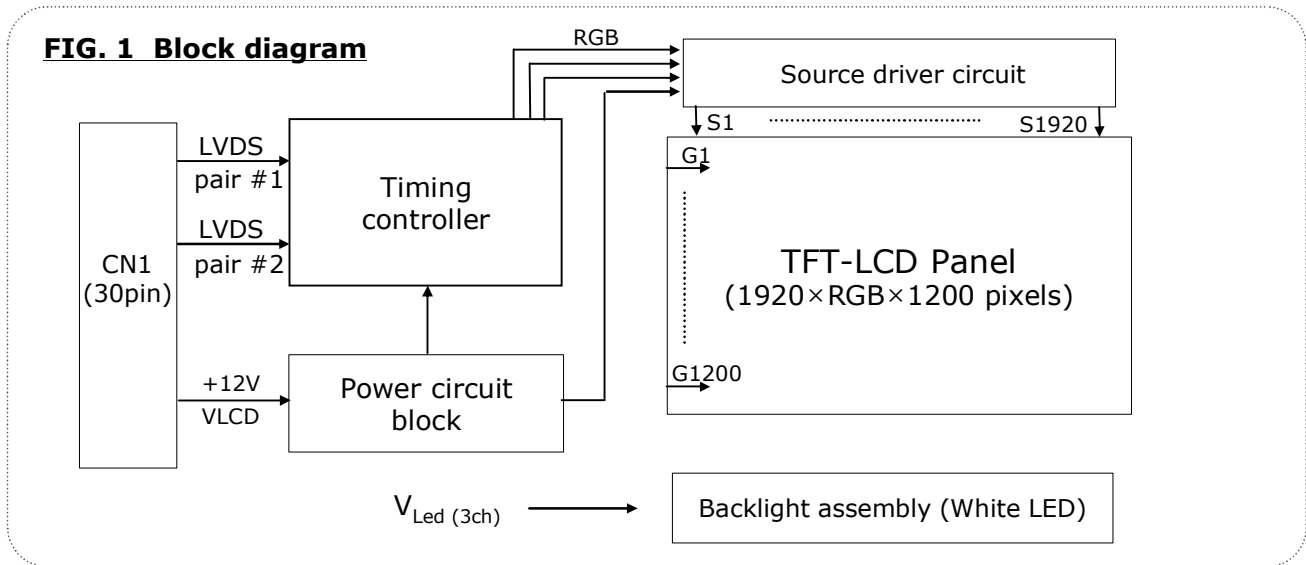

**General features**

Active screen size	24.1 inches(61.13cm) diagonal (Aspect ratio 16:10)
Outline Dimension	546.4(H) x 352.0(V) x 11.7(D) mm (Typ.)
Pixel Pitch	0.270 mm x 0.270 mm
Pixel Format	1920 hor. By 1200 Vertical Pixels RGB stripes arrangement
Interface	LVDS 2Port
Color depth	16.7M colors (6bit+A-FRC)
Luminance, white	350 cd/m <sup>2</sup> ( Center 1Point, typ)
Viewing Angle (CR>10)	R/L 178(Typ.), U/D 178(Typ.)
Power Consumption	Total 18.66 Watt (Typ.) ( 3.96 Watt @VLCD, 14.7 Watt @Vled)
Weight	2620g(Typ.)
Display operating mode	Transmissive mode, normally Black
Surface treatments	Hard coating(3H), Anti-Glare treatment of the front polarizer

Product Specification

2. Absolute maximum ratings

The following are maximum values which, if exceeded, may cause faulty operation or damage to the unit.

Table 1. Absolute maximum ratings

Parameter	Symbol	Values		Units	Notes
		Min	Max		
Power Supply Input Voltage	$V_{LCD}$	-0.3	+14.0	Vdc	at $25 \pm 2^\circ\text{C}$
Operating Temperature	$T_{OP}$	0	50	$^\circ\text{C}$	1, 2, 3
Storage Temperature	$T_{ST}$	-20	60	$^\circ\text{C}$	
Operating Ambient Humidity	$H_{OP}$	10	90	%RH	
Storage Humidity	$H_{ST}$	10	90	%RH	
LCM Surface Temperature (Operation)	$T_{Surface}$	0	65	$^\circ\text{C}$	1,4

- Note : 1. Temperature and relative humidity range are shown in the figure below.  
 Wet bulb temperature should be  $39^\circ\text{C}$  Max, and no condensation of water.  
 2. Maximum Storage Humidity is up to  $40^\circ\text{C}$ , 70% RH only for 4 corner light leakage Mura.  
 3. Storage condition is guaranteed under packing condition.  
 4. LCM Surface Temperature should be Min.  $0^\circ\text{C}$  and Max.  $65^\circ\text{C}$  under the VLCD=12V,  $fV=60\text{Hz}$ ,  $25^\circ\text{C}$  ambient Temperature no humidity control and LED string current is typical value.

FIG. 2 Temperature and relative humidity

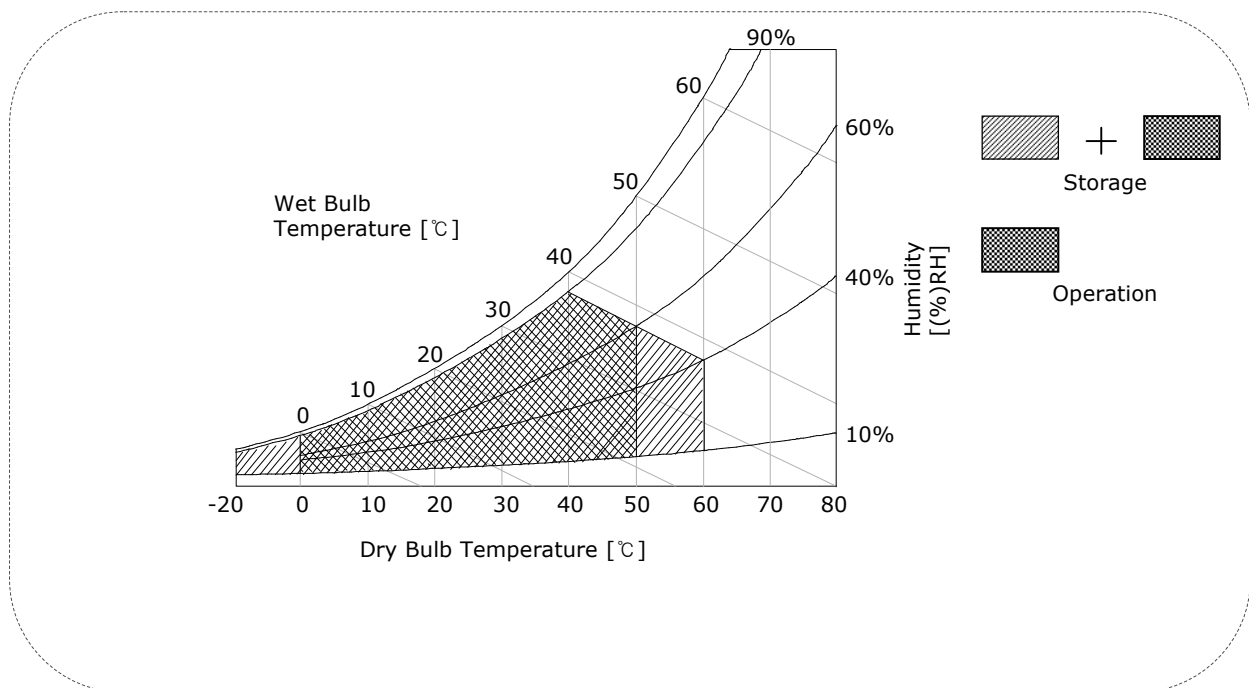

**Product Specification**

**3. Electrical specifications**

**3-1. Electrical characteristics**

It requires two power inputs. One is employed to power the LCD electronics and to drive the TFT array and liquid crystal. The second input power for the LED Backlight, is typically generated by an LED Driver. The LED Driver is an external unit to the LCDs.

**Table 2-1. Electrical characteristics**

Parameter	Symbol	Values			Unit	Notes
		Min	Typ	Max		
MODULE :						
Power Supply Input Voltage	$V_{LCD}$	11.4	12.0	12.6	Vdc	
Permissive Power Input Ripple	$V_{LCD}$	-	-	0.4	V	3
Power Supply Input Current	$I_{LCD-MOSAIC}$	280	330	378	Ma	1
	$I_{LCD-WHITE}$	370	436	502	mA	2
Power Consumption	$P_{LCD}$	-	3.96	4.56	Watt	1
Inrush current	$I_{RUSH}$	-	-	3.0	A	4

Note :

1. The specified current and power consumption are under the  $V_{LCD}=12.0V, 25 \pm 2^{\circ}C, f_v=60Hz$  condition whereas mosaic pattern(8 x 6) is displayed and  $f_v$  is the frame frequency.
2. The current is specified at the maximum current pattern.
3. Permissive power ripple should be measured under  $VCC=12.0V, 25^{\circ}C, f_v$  (frame frequency)=Max condition and At that time, we recommend the bandwidth configuration of oscilloscope is to be under 20MHz.
4. The duration of rush current is about 2ms and rising time of power Input is  $500us \pm 20\%$ .

**FIG.3 pattern for Electrical characteristics**

power consumption measurement

White : 255Gray  
Black : 0Gray

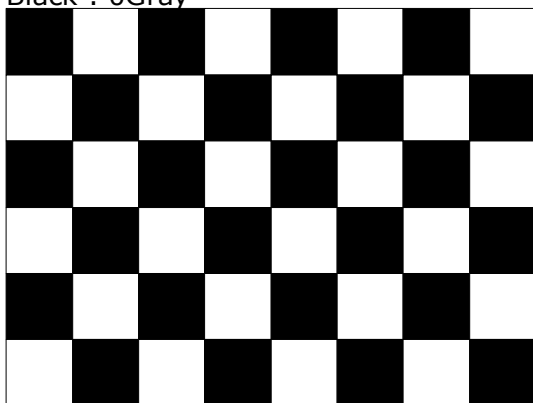

Mosaic Pattern(8 x 6)

power input ripple



Full White Pattern

**Product Specification**

**Table 2-2 . LED Bar ELECTRICAL CHARACTERISTICS**

Parameter	Symbol	Condition	Values			Unit	Notes
			Min.	Typ.	Max.		
LED String Current	Is		-	120	125	mA	1,2,5
LED String Voltage	Vs		38.4	41	43.6	V	1,5
Power Consumption	PBar		-	14.7	15.7	Watt	1,2,4
LED Life Time	LED_LT		30,000	-	-	Hrs	3

Notes) The LED Bar consists of 39 LED packages, 3 strings (parallel) x 13 packages (serial)

LED driver design guide

- 1) The design of the LED driver must have specifications for the LED in LCD Assembly.  
 The performance of the LED in LCM, for example life time or brightness, is extremely influenced by the characteristics of the LED driver.  
 So all the parameters of an LED driver should be carefully designed and output current should be Constant current control.  
 Please control feedback current of each string individually to compensate the current variation among the strings of LEDs.  
 When you design or order the LED driver, please make sure unwanted lighting caused by the mismatch of the LED and the LED driver (no lighting, flicker, etc) never occurs.  
 When you confirm it, the LCD module should be operated in the same condition as installed in your instrument.
- 2) LGD recommend that Dimming Control Signal ( PWM Signal) is synchronized with Frame Frequency for Wavy Noise Free.

Notes :

1. The specified values are for a single LED bar.
2. The specified current is defined as the input current for a single LED string with 100% duty cycle.
3. The LED life time is defined as the time when brightness of LED packages become 50% or less than the initial value under the conditions at  $T_a = 25 \pm 2^\circ\text{C}$  and LED string current is typical value.
4. The power consumption shown above does not include loss of external driver.  
 The typical power consumption is calculated as  $P_{\text{Bar}} = V_s(\text{Typ.}) \times I_s(\text{Typ.}) \times \text{No. of strings}$ .  
 The maximum power consumption is calculated as  $P_{\text{Bar}} = V_s(\text{Max.}) \times I_s(\text{Typ.}) \times \text{No. of strings}$ .
5. LED operating conditions must not exceed Max. ratings.

**Product Specification**

### 3-2. Interface connections

- LCD Connector(CN1) : GT103-30S-H23-D (LSM), KDF71G-30S-1H(Hirose) or Equivalent
- Mating Connector : FI-X30C2L (Manufactured by JAE) or Equivalent

**Table 3. Module connector(CN1) pin configuration**

Pin No	Symbol	Description	
1	RX00-	Minus signal of 1st channel 0 (LVDS)	} First Pixel data
2	RX00+	Plus signal of 1st channel 0 (LVDS)	
3	RX01-	Minus signal of 1st channel 1 (LVDS)	
4	RX01+	Plus signal of 1st channel 1 (LVDS)	
5	RX02-	Minus signal of 1st channel 2 (LVDS)	
6	RX02+	Plus signal of 1st channel 2 (LVDS)	
7	GND	Ground	
8	RXOC-	Minus signal of 1st clock channel (LVDS)	} Second Pixel data
9	RXOC+	Plus signal of 1st clock channel (LVDS)	
10	RX03-	Minus signal of 1st channel 3 (LVDS)	
11	RX03+	Plus signal of 1st channel 3 (LVDS)	
12	RXE0-	Minus signal of 2nd channel 0 (LVDS)	
13	RXE0+	Plus signal of 2nd channel 0 (LVDS)	
14	GND	Ground	
15	RXE1-	Minus signal of 2nd channel 1 (LVDS)	} Second Pixel data
16	RXE1+	Plus signal of 2nd channel 1 (LVDS)	
17	GND	Ground	
18	RXE2-	Minus signal of 2nd channel 2 (LVDS)	
19	RXE2+	Plus signal of 2nd channel 2 (LVDS)	
20	RXEC-	Minus signal of 2nd clock channel (LVDS)	
21	RXEC+	Plus signal of 2nd clock channel (LVDS)	
22	RXE3-	Minus signal of 2nd channel 3 (LVDS)	} Second Pixel data
23	RXE3+	Plus signal of 2nd channel 3 (LVDS)	
24	GND	Ground	
25	NC	No Connection (For LCD internal use only.)	
26	NC	No Connection (For LCD internal use only.)	
27	PWM	PWM_OUT for Wavy Noise	
28	V <sub>LCD</sub>	Power Supply (12.0V)	
29	V <sub>LCD</sub>	Power Supply (12.0V)	
30	V <sub>LCD</sub>	Power Supply (12.0V)	



**Product Specification**

**FIG. 4 Connector diagram**

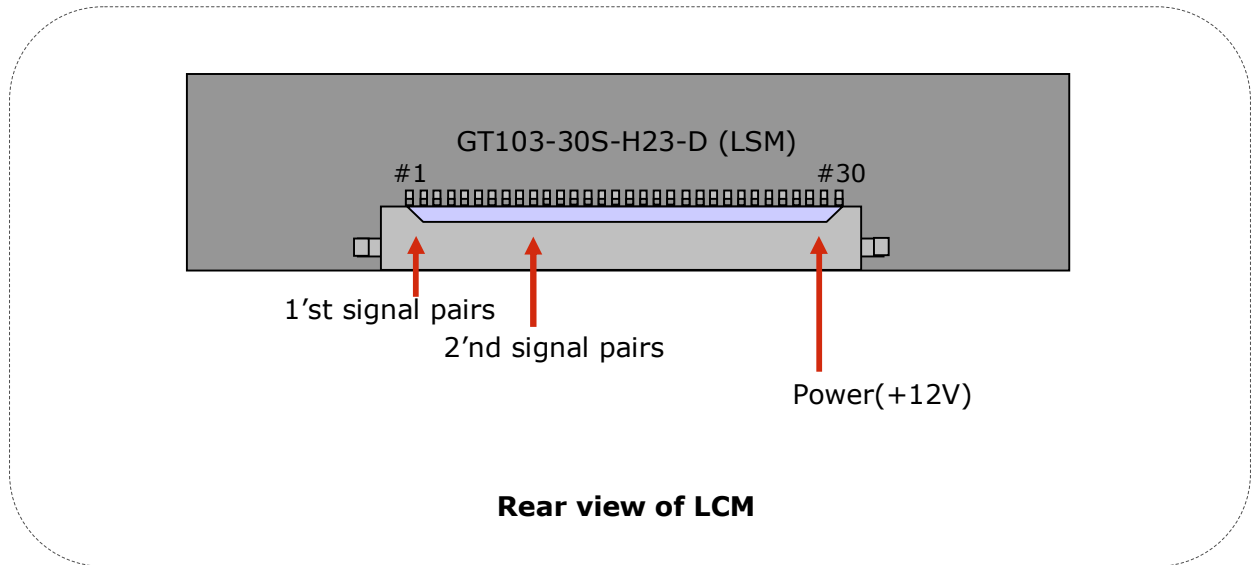

**Note:**

1. NC: No Connection.
2. All GND(ground) pins should be connected together and to V<sub>SS</sub> which should also be connected to the LCD's metal frame.
3. All V<sub>LCD</sub> (power input) pins should be connected together.
4. Input Level of LVDS signal is based on the IEA 664 Standard.

**Product Specification**

**Table 4. BACKLIGHT CONNECTOR PIN CONFIGURATION(CN2)**

The LED interface connector is a model SM06B-SHJH(HF), wire-locking type manufactured by JST. The mating connector is a SHJP-06V-S(HF) or SHJP-06V-A-K(HF) and Equivalent. The pin configuration for the connector is shown in the table below.

Pin	Symbol	Description	Notes
1	FB1	Channel1 Current Feedback	
2	NC	No Connection	
3	VLED	LED Power Supply	
4	VLED	LED Power Supply	
5	FB2	Channel2 Current Feedback	
6	FB3	Channel3 Current Feedback	

**FIG. 5 Backlight connector diagram**

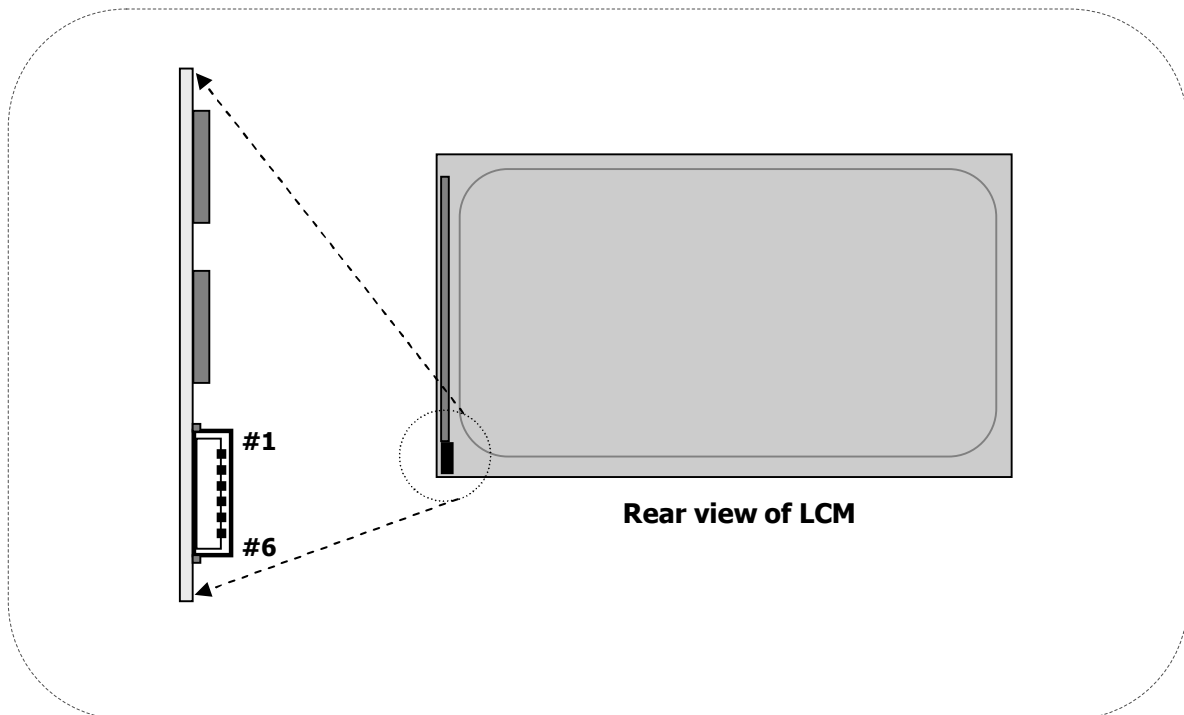

Product Specification

3-3. LVDS characteristics

3-3-1. DC Specification

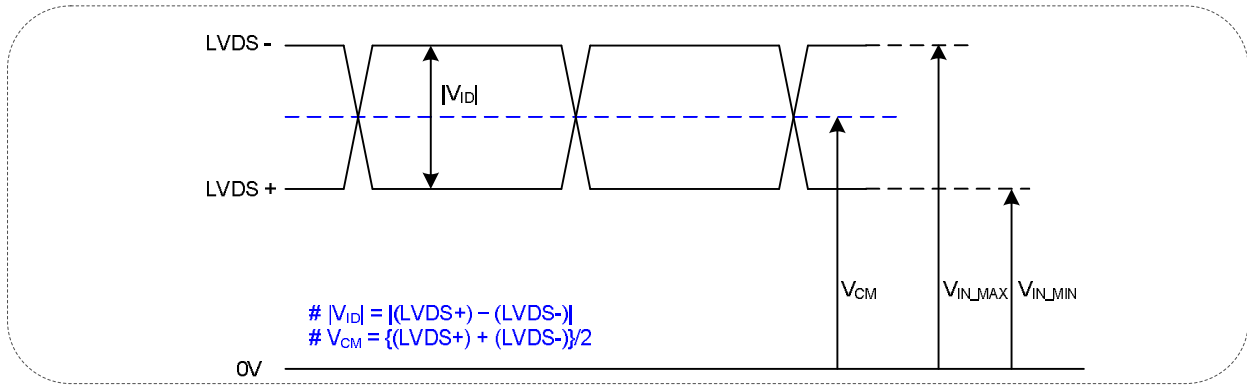

Description	Symbol	Min	Max	Unit	Notes
LVDS Differential Voltage	$ V_{ID} $	200	600	mV	-
LVDS Common mode Voltage	$V_{CM}$	0.6	1.5	V	-
LVDS Input Voltage Range	$V_{IN}$	0.3	1.8	V	-

3-3-2. AC Specification

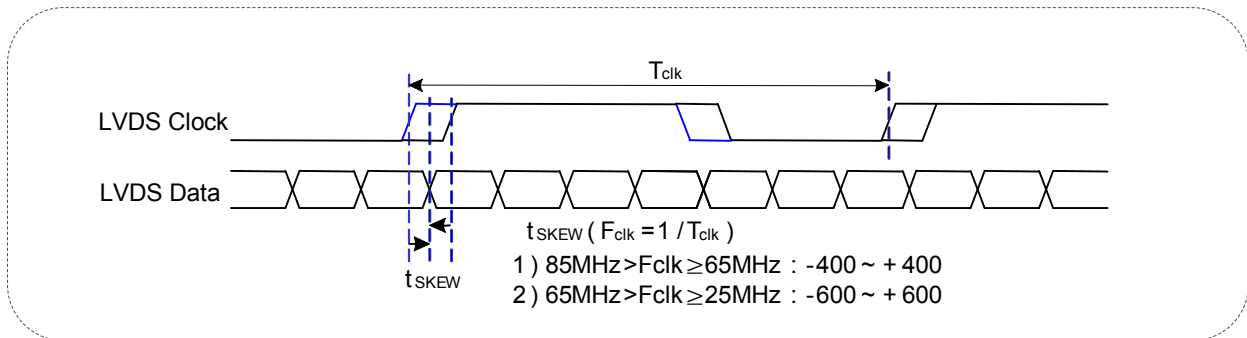

Description	Symbol	Min	Max	Unit	Notes
LVDS Clock to Data Skew Margin	$t_{SKEW}$	- 400	+ 400	ps	85MHz > Fclk ≥ 65MHz
	$t_{SKEW}$	- 600	+ 600	ps	65MHz > Fclk ≥ 25MHz
LVDS Clock to Clock Skew Margin (Even to Odd)	$t_{SKEW\_EO}$	- 1/7	+ 1/7	$T_{clk}$	-

Note 1 :

This SSC specifications are just T-CON operation specification. In case of various system condition, the optimum setting value of SSC can be different. LGD recommend the SI should be adjust the SSC deviation and modulation frequency in order not to happen any kinds of defect phenomenon.

**Product Specification**

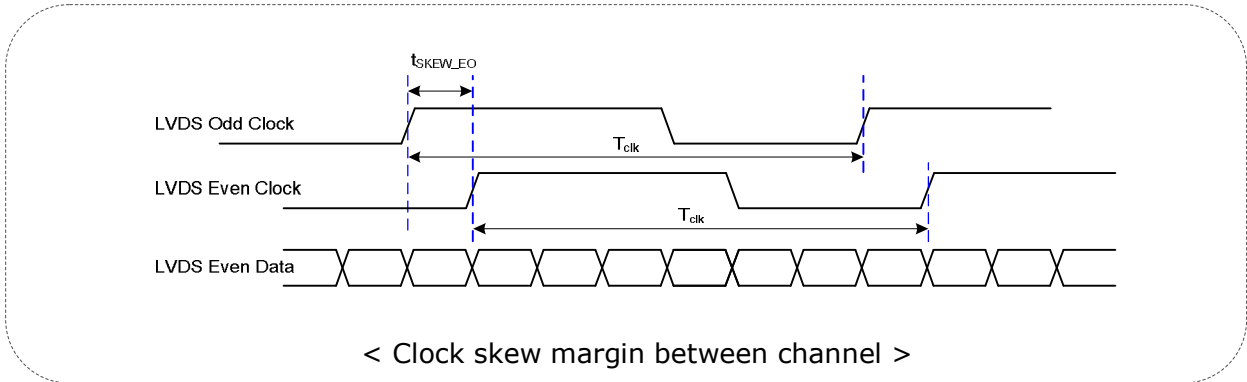

3-3-3. LVDS Data format

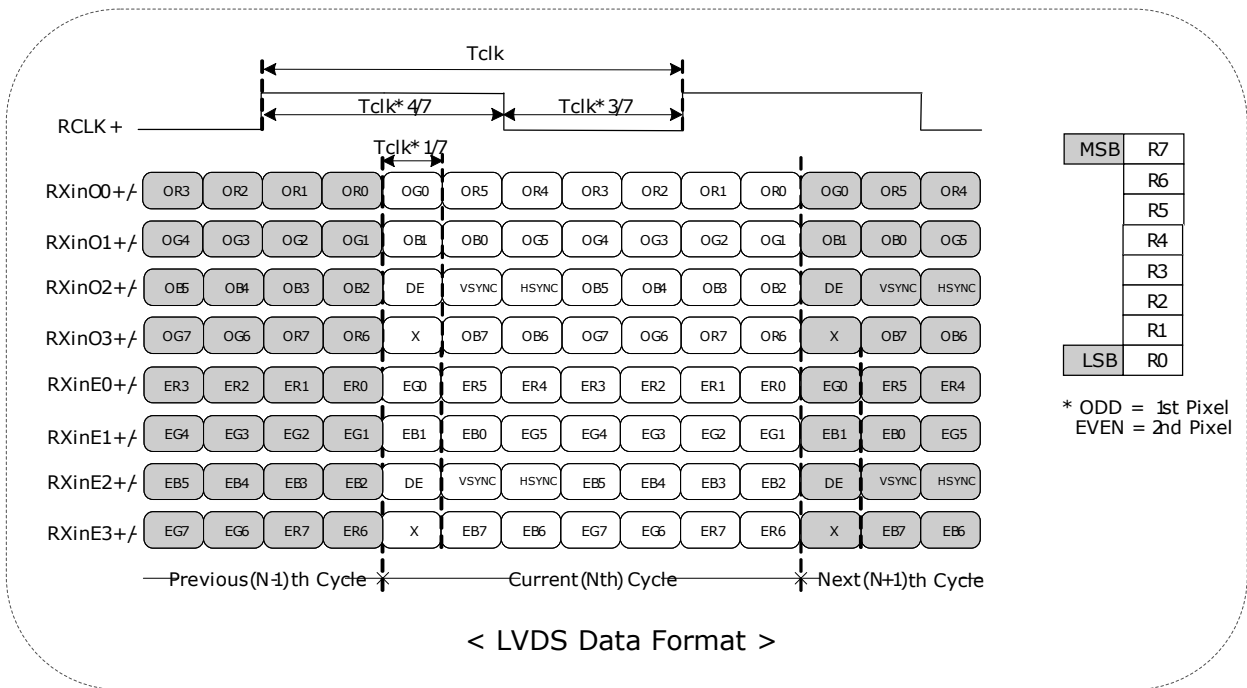

**Product Specification**
**Table 5. Required signal assignment for Flat Link(NS:DS90CF383) transmitter**

Pin #	Pin Name	Require Signal	Pin #	Pin Name	Require Signal
1	VCC	Power Supply for TTL Input	29	GND	Ground pin for TTL
2	D5	TTL Input (R7)	30	D26	TTL Input (DE)
3	D6	TTL Input (R5)	31	T <sub>x</sub> CLKIN	TTL Level clock Input
4	D7	TTL Input (G0)	32	PWR DWN	Power Down Input
5	GND	Ground pin for TTL	33	PLL GND	Ground pin for PLL
6	D8	TTL Input (G1)	34	PLL VCC	Power Supply for PLL
7	D9	TTL Input (G2)	35	PLL GND	Ground pin for PLL
8	D10	TTL Input (G6)	36	LVDS GND	Ground pin for LVDS
9	VCC	Power Supply for TTL Input	37	TxOUT3 +	Positive LVDS differential data output 3
10	D11	TTL Input (G7)	38	TxOUT3 -	Negative LVDS differential data output 3
11	D12	TTL Input (G3)	39	T <sub>x</sub> CLKOUT +	Positive LVDS differential clock output
12	D13	TTL Input (G4)	40	T <sub>x</sub> CLKOUT -	Negative LVDS differential clock output
13	GND	Ground pin for TTL	41	T <sub>x</sub> OUT2 +	Positive LVDS differential data output 2
14	D14	TTL Input (G5)	42	T <sub>x</sub> OUT2 -	Negative LVDS differential data output 2
15	D15	TTL Input (B0)	43	LVDS GND	Ground pin for LVDS
16	D16	TTL Input (B6)	44	LVDS VCC	Power Supply for LVDS
17	VCC	Power Supply for TTL Input	45	T <sub>x</sub> OUT1 +	Positive LVDS differential data output 1
18	D17	TTL Input (B7)	46	T <sub>x</sub> OUT1 -	Negative LVDS differential data output 1
19	D18	TTL Input (B1)	47	T <sub>x</sub> OUT0 +	Positive LVDS differential data output 0
20	D19	TTL Input (B2)	48	T <sub>x</sub> OUT0 -	Negative LVDS differential data output 0
21	GND	Ground pin for TTL Input	49	LVDS GND	Ground pin for LVDS
22	D20	TTL Input (B3)	50	D27	TTL Input (R6)
23	D21	TTL Input (B4)	51	D0	TTL Input (R0)
24	D22	TTL Input (B5)	52	D1	TTL Input (R1)
25	D23	TTL Input (RSVD)	53	GND	Ground pin for TTL
26	VCC	Power Supply for TTL Input	54	D2	TTL Input (R2)
27	D24	TTL Input (HSYNC)	55	D3	TTL Input (R3)
28	D25	TTL Input (VSYNC)	56	D4	TTL Input (R4)

Notes : 1. Refer to LVDS Transmitter Data Sheet for detail descriptions.  
 2. 7 means MSB and 0 means LSB at R,G,B pixel data

**Product Specification**
**3-4. Signal timing specifications**

This is the signal timing required at the input of the User connector. All of the interface signal timing should be satisfied with the following specifications for it's proper operation.

**Table 6. TIMING TABLE (VESA COORDINATED VIDEO TIMING)**

ITEM		SYMBOL	Min	Typ	Max	Unit	Note
DCLK	Period	tCLK	12.19	12.98	16.06	ns	Pixel frequency : Typ. 154MHz
	Frequency	fCLK	62.24	77	82	MHz	
Hsync	Period	tHP	1013	1040	1048	tCLK	
	Width-Active	tWH	16	16	16		
Vsync	Period	tVP	1229	1235	1390	tHP	
	Frequency	fV	49.5	59.95	61	Hz	
	Width-Active	tWV	6	6	6	tHP	
Data Enable	Horizontal Valid	tHV	960	960	960	tCLK	
	Horizontal Back Porch	tHBP	21	40	44		
	Horizontal Front Porch	tHFP	16	24	28		
	Horizontal Blank	-	53	80	88		tWH+ tHBP+ tHFP
	Vertical Valid	tVv	1200	1200	1200	tHP	
	Vertical Back Porch	tVBP	21	26	180		
	Vertical Front Porch	tVFP	2	3	4		
	Vertical Blank	-	29	35	190		tWV+ tVBP+ tVFP

Note:

1. DE Only mode operation. The input of Hsync & Vsync signal does not have an effect on LCD normal operation.
2. The performance of the electro-optical characteristics may be influenced by variance of the vertical refresh rates.
3. Horizontal period should be even.

**3-5. Signal timing waveforms**

1. D<sub>CLK</sub>, DE, DATA waveforms

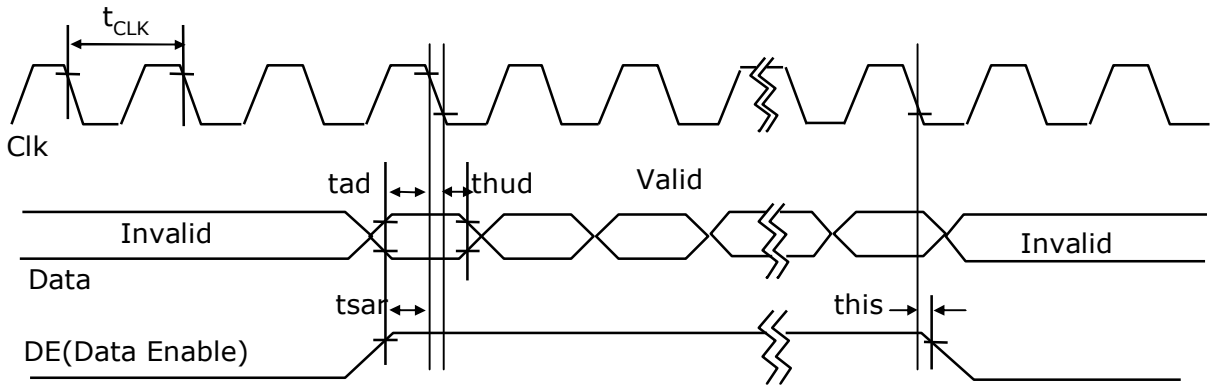

2. Horizontal waveform

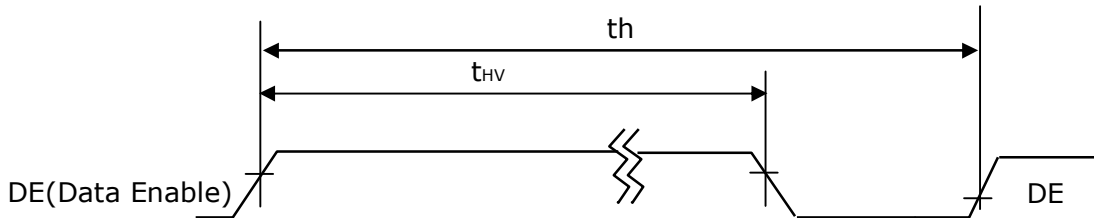

3. Vertical waveform

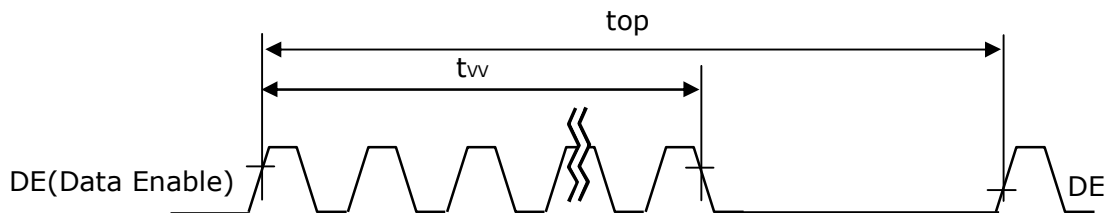

**Product Specification**

**3-6. Color input data reference**

The brightness of each primary color (red, green and blue) is based on the 8bit gray scale data input for the color ; the higher the binary input, the brighter the color. The table below provides a reference for color versus data input.

**Table 7. Color data reference**

Color		Input Color Data																							
		Red								Green								Blue							
		MSB				LSB				MSB				LSB				MSB				LSB			
		R7	R6	R5	R4	R3	R2	R1	R0	G7	G6	G5	G4	G3	G2	G1	G0	B7	B6	B5	B4	B3	B2	B1	B0
Basic Color	Black	0	0	0	0	0	0	0	0	0	0	0	0	0	0	0	0	0	0	0	0	0	0	0	0
	Red (255)	1	1	1	1	1	1	1	1	0	0	0	0	0	0	0	0	0	0	0	0	0	0	0	0
	Green (255)	0	0	0	0	0	0	0	0	1	1	1	1	1	1	1	1	0	0	0	0	0	0	0	0
	Blue (255)	0	0	0	0	0	0	0	0	0	0	0	0	0	0	0	0	1	1	1	1	1	1	1	1
	Cyan	0	0	0	0	0	0	0	0	1	1	1	1	1	1	1	1	1	1	1	1	1	1	1	1
	Magenta	1	1	1	1	1	1	1	1	0	0	0	0	0	0	0	0	1	1	1	1	1	1	1	1
	Yellow	1	1	1	1	1	1	1	1	1	1	1	1	1	1	1	1	0	0	0	0	0	0	0	0
	White	1	1	1	1	1	1	1	1	1	1	1	1	1	1	1	1	1	1	1	1	1	1	1	1
Red	Red(000) Dark	0	0	0	0	0	0	0	0	0	0	0	0	0	0	0	0	0	0	0	0	0	0	0	0
	Red(001)	0	0	0	0	0	0	0	1	0	0	0	0	0	0	0	0	0	0	0	0	0	0	0	0
	Red(002)	0	0	0	0	0	0	1	0	0	0	0	0	0	0	0	0	0	0	0	0	0	0	0	0
	-----	-	-	-	-	-	-	-	-	-	-	-	-	-	-	-	-	-	-	-	-	-	-	-	-
	-----	-	-	-	-	-	-	-	-	-	-	-	-	-	-	-	-	-	-	-	-	-	-	-	-
	Red(253)	1	1	1	1	1	1	0	1	0	0	0	0	0	0	0	0	0	0	0	0	0	0	0	0
	Red(254)	1	1	1	1	1	1	1	0	0	0	0	0	0	0	0	0	0	0	0	0	0	0	0	0
	Red(255) Bright	1	1	1	1	1	1	1	1	0	0	0	0	0	0	0	0	0	0	0	0	0	0	0	0
Green	Green(000) Dark	0	0	0	0	0	0	0	0	0	0	0	0	0	0	0	0	0	0	0	0	0	0	0	0
	Green(001)	0	0	0	0	0	0	0	0	0	0	0	0	0	0	1	0	0	0	0	0	0	0	0	0
	Green(002)	0	0	0	0	0	0	0	0	0	0	0	0	0	1	0	0	0	0	0	0	0	0	0	0
	-----	-	-	-	-	-	-	-	-	-	-	-	-	-	-	-	-	-	-	-	-	-	-	-	-
	-----	-	-	-	-	-	-	-	-	-	-	-	-	-	-	-	-	-	-	-	-	-	-	-	-
	Green(253)	0	0	0	0	0	0	0	0	1	1	1	1	1	1	0	1	0	0	0	0	0	0	0	0
	Green(254)	0	0	0	0	0	0	0	0	1	1	1	1	1	1	1	0	0	0	0	0	0	0	0	0
	Green(255)Bright	0	0	0	0	0	0	0	0	1	1	1	1	1	1	1	1	0	0	0	0	0	0	0	0
Blue	Blue(000) Dark	0	0	0	0	0	0	0	0	0	0	0	0	0	0	0	0	0	0	0	0	0	0	0	0
	Blue(001)	0	0	0	0	0	0	0	0	0	0	0	0	0	0	0	0	0	0	0	0	0	0	0	1
	Blue(002)	0	0	0	0	0	0	0	0	0	0	0	0	0	0	0	0	0	0	0	0	0	0	1	0
	-----	-	-	-	-	-	-	-	-	-	-	-	-	-	-	-	-	-	-	-	-	-	-	-	-
	-----	-	-	-	-	-	-	-	-	-	-	-	-	-	-	-	-	-	-	-	-	-	-	-	-
	Blue(253)	0	0	0	0	0	0	0	0	0	0	0	0	0	0	0	1	1	1	1	1	1	1	0	1
	Blue(254)	0	0	0	0	0	0	0	0	0	0	0	0	0	0	0	1	1	1	1	1	1	1	1	0
	Blue(255) Bright	0	0	0	0	0	0	0	0	0	0	0	0	0	0	0	1	1	1	1	1	1	1	1	1



**Product Specification**

**3-7. Power sequence**

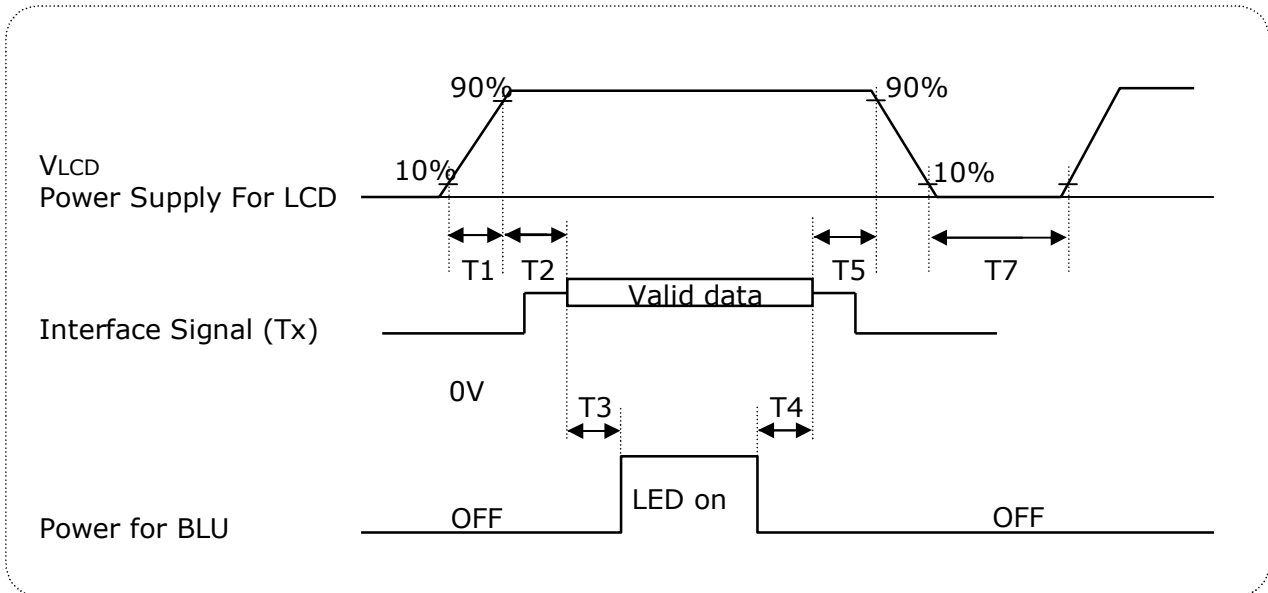

**Table 8. Power sequence**

Parameter	Values			Units
	Min	Typ	Max	
T1	0.5	-	10	ms
T2	0.01	-	50	ms
T3	200	-	-	ms
T4	200	-	-	ms
T5	0.01	-	50	ms
T7	1	-	-	s

**Notes :**

1. Please V<sub>LCD</sub> power on only after connecting interface cable to LCD.
2. Please avoid floating state of interface signal at invalid period.
3. When the interface signal is invalid, be sure to pull down the power supply for LCD V<sub>LCD</sub> to 0V.
4. LED power must be turn on after power supply for LCD an interface signal are valid.

### 3-8. V<sub>LCD</sub> Power dip condition

FIG. 6 Power dip condition

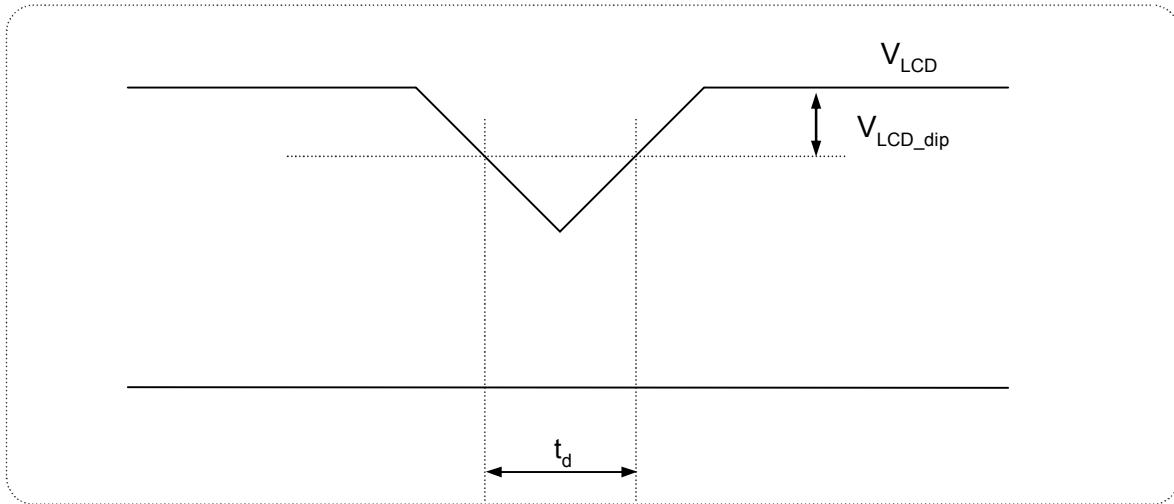

Dip condition

$$V_{LCD\_dip} \leq V_{LCD\_typ} \times 0.2, \quad t_d \leq 20ms$$

**Product Specification**

**4. Optical specification**

Optical characteristics are determined after the unit has been 'ON' for 30 minutes in a dark environment at 25°C. The values specified are at an approximate distance 50cm from the LCD surface at a viewing angle of  $\Phi$  and  $\theta$  equal to 0°.

FIG. 7 presents additional information concerning the measurement equipment and method.

**FIG. 7 Optical characteristic measurement equipment and method**

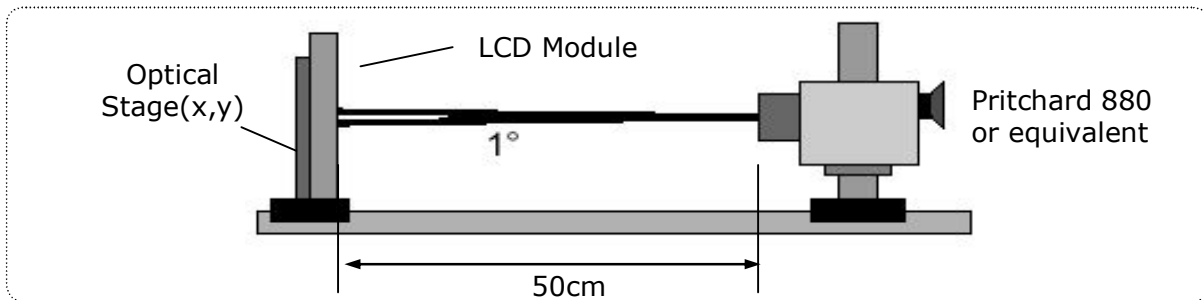

**Table 9. Optical characteristics**

Ta= 25°C, V<sub>LCD</sub>=12.0V, fv=60Hz, D<sub>CLK</sub>=154MHz, Is=120mA

Parameter	Symbol	Values			Units	Notes	
		Min	Typ	Max			
Contrast Ratio	CR	700	1000			1	
Surface Luminance, white	L <sub>WH</sub>	280	350		cd/m <sup>2</sup>	2	
Luminance Variation	$\delta_{\text{WHITE}}$	75			%	3	
Response Time	Gray to Gray	T <sub>GTG_AVR</sub>	-	14	28	ms	4
Color Coordinates [CIE1931] (By PR650)	RED	R <sub>x</sub>		0.653			
		R <sub>y</sub>		0.332			
	GREEN	G <sub>x</sub>		0.304			
		G <sub>y</sub>	Typ	0.633	Typ		
	BLUE	B <sub>x</sub>	-0.03	0.150	+0.03		
		B <sub>y</sub>		0.064			
	WHITE	W <sub>x</sub>		0.313			
	W <sub>y</sub>		0.329				
Color Shift (Avg. $\Delta u'v' < 0.02$ )	Horizontal	$\theta_{\text{CST}_H}$	-	100	-	Degree	5
	Vertical	$\theta_{\text{CST}_V}$	-	140	-		
Viewing Angle (CR>10)							
General	Horizontal	$\theta_H$	170	178	-	Degree	6
	Vertical	$\theta_V$	170	178	-		
GSR @ 60dgree (Gamma shift rate)	Horizontal	$\delta_{\text{Gamma}_H}$	-	-	20	%	7
	Vertical	$\delta_{\text{Gamma}_V}$	-	-	20		
Gray Scale				2.2			8

**Product Specification**

Notes 1. Contrast Ratio(CR) is defined mathematically as : (By PR880)

$$\text{Contrast Ratio} = \frac{\text{Surface Luminance with all white pixels}}{\text{Surface Luminance with all black pixels}}$$

It is measured at center point(Location P1)

2. Surface luminance(L<sub>WH</sub>)is luminance value at Center 1 point(P1) across the LCD surface 50cm from the surface with all pixels displaying white. For more information see FIG 7. (By PR880)

3. The variation in surface luminance , δ WHITE is defined as : (By PR880)

$$\delta_{\text{WHITE}} = \frac{\text{Minimum}(L_{P1}, L_{P2}, \dots, L_{P9})}{\text{Maximum}(L_{P1}, L_{P2}, \dots, L_{P9})} \times 100$$

Where L1 to L9 are the luminance with all pixels displaying white at 9 locations.  
For more information see FIG 8.

4. Gray to gray response time is the time required for the display to transition from gray to gray. For additional information see Table 10. (By RD80S)

5. Color shift is the angle at which the average color difference for all Macbeth is lower than 0.02. For more information see FIG 9. (By EZ Contrast)

- Color difference (Δu'v')

$$u' = \frac{4x}{-2x + 12y + 3} \quad v' = \frac{9y}{-2x + 12y + 3} \quad \Delta u'v' = \sqrt{(u'_1 - u'_2)^2 + (v'_1 - v'_2)^2}$$

$$\text{Avg}(\Delta u'v') = \frac{\sum_{i=1}^{24} (\Delta u'v')_i}{24}$$

u'1, v'1 : u'v' value at viewing angle direction  
u'2, v'2 : u'v' value at front (θ=0)  
i : Macbeth chart number (Define 22 page)

- Pattern size : 25% Box size

- Viewing angle direction of color shift : Horizontal, Vertical

6. Viewing angle is the angle at which the contrast ratio is greater than 10. The angles are determined for the horizontal or x axis and the vertical or y axis with respect to the z axis which is normal to the LCD surface. For more information see FIG 10. (By PR880)

7. GSR is the rate of gamma shift at up, down, left and right 60 degree viewing angle compare with center gamma. For more information see FIG 11 and FIG 12 (By EZ Contrast)

- GSR (δ<sub>Gamma</sub>) is defined as :

$$\text{GSR} = \left( 1 - \frac{\text{View angle Gamma Value (Up, Down, Ref, Light 60 Degree)}}{\text{Center Gamma Value (0 Degree)}} \right) \times 100$$

**Product Specification**

Notes 8. Gray scale specification

Gamma Value is approximately 2.2. For more information see Table 11.

Measuring point for surface luminance & measuring point for luminance variation.

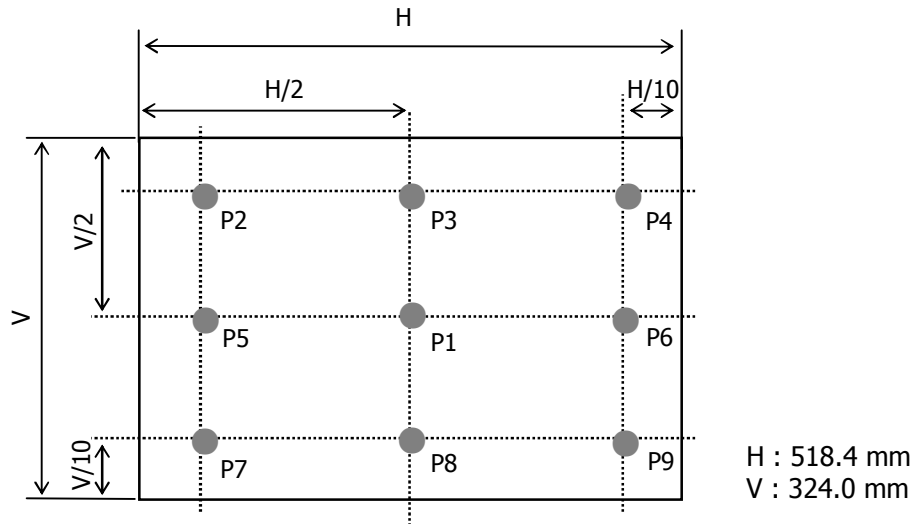

**FIG. 8 Measure Point for Luminance**

The gray to gray response time is defined as the following figure and shall be measured by switching the input signal for "Gray To Gray".

- Gray step : 5 step
- $T_{GTG\_AVR}$  is the total average time at rising time and falling time for "Gray To Gray".
- In case of the difference in measured values due to the difference of measuring device or program was found, correlated value will be used after discussions between both parties.

**Table 10. Gray to gray response time table**

Gray to Gray		Rising Time				
		G255	G191	G127	G63	G0
Falling Time	G255					
	G191					
	G127					
	G63					
	G0					

**Product Specification**

Color shift is defined as the following test pattern and color.

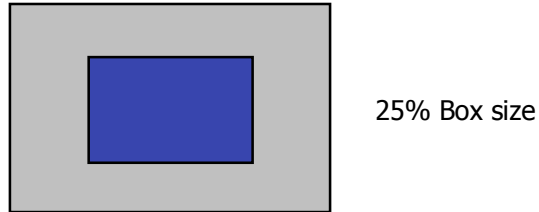

**FIG. 9 Color Shift Test Pattern**

Average RGB values in Bruce RGB for Macbeth Chart

	Dark skin	Light skin	Blue sky	Foliage	Blue flower	Bluish green
R	395	827	343	311	519	459
G	227	571	451	411	475	799
B	183	495	647	187	743	715
	Orange	Purplish blue	Moderate red	Purple	Yellow green	Orange yellow
R	879	227	847	307	643	923
G	419	279	271	159	775	651
B	99	699	351	347	235	119
	Blue	Green	Red	Yellow	Magenta	cyan
R	107	291	791	967	831	143
G	131	595	111	851	251	507
B	583	263	151	147	607	691
	White	Neutral 8	Neutral 6.5	Neutral 5	Neutral 3.5	black
R	963	827	623	443	255	91
G	963	827	623	443	255	91
B	963	827	623	443	255	91

Product Specification

Dimension of viewing angle range.

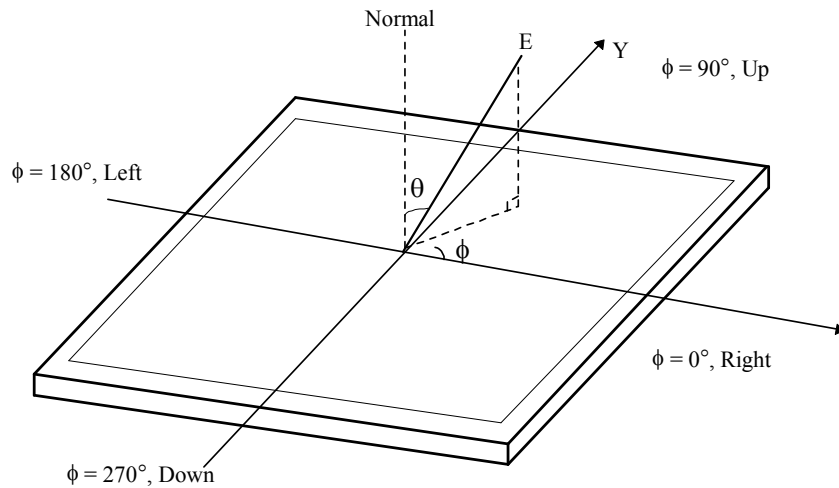

FIG. 10 Viewing angle

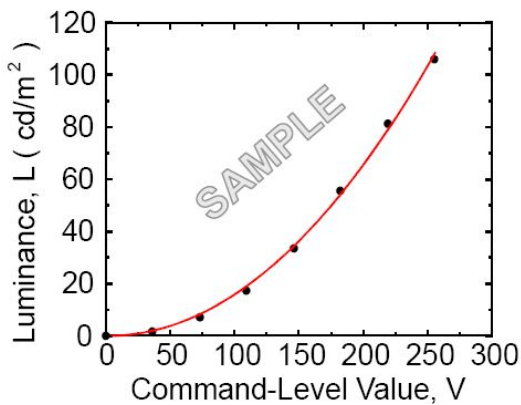

FIG. 11 Sample Luminance vs. gray scale (using a 256 bit gray scale)

$$L = aV^r + L_b$$

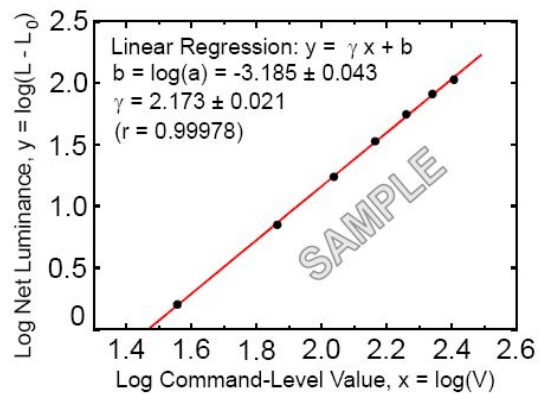

FIG. 12 Sample Log-log plot of luminance vs. gray scale

$$\log(L - L_b) = r \log(V) + \log(a)$$

Here the Parameter  $\alpha$  and  $\gamma$  relate the signal level  $V$  to the luminance  $L$ .  
The GAMMA we calculate from the log-log representation (FIG. 11)

**Product Specification**

**Table 11. Gray Scale Specification**

Gray Level	Relative Luminance [%] (Typ.)
L0	0.10
L15	0.30
L31	1.08
L47	2.50
L63	4.72
L79	7.70
L95	11.49
L111	16.20
L127	21.66
L143	28.20
L159	35.45
L175	43.8
L191	53.0
L207	63.3
L223	74.48
L239	86.8
L255	100



**Product Specification**

## 5. Mechanical characteristics

The contents provide general mechanical characteristics. In addition the figures in the next page are detailed mechanical drawing of the LCD.

**Table 12. Mechanical characteristics**

<b>Outline dimension</b>	Horizontal	546.4mm
	Vertical	352.0mm
	Depth	11.7 mm
<b>Bezel area</b>	Horizontal	522.4mm
	Vertical	328.0mm
<b>Active display area</b>	Horizontal	518.4mm
	Vertical	324.0mm
<b>Weight</b>	2620g (Typ.), 2750g(Max)	
<b>Surface treatment</b>	Hard coating(3H) Anti-Glare treatment of the front polarizer	

Notes : Please refer to a mechanic drawing in terms of tolerance at the next page.

**Product Specification**

**< FRONT VIEW >**

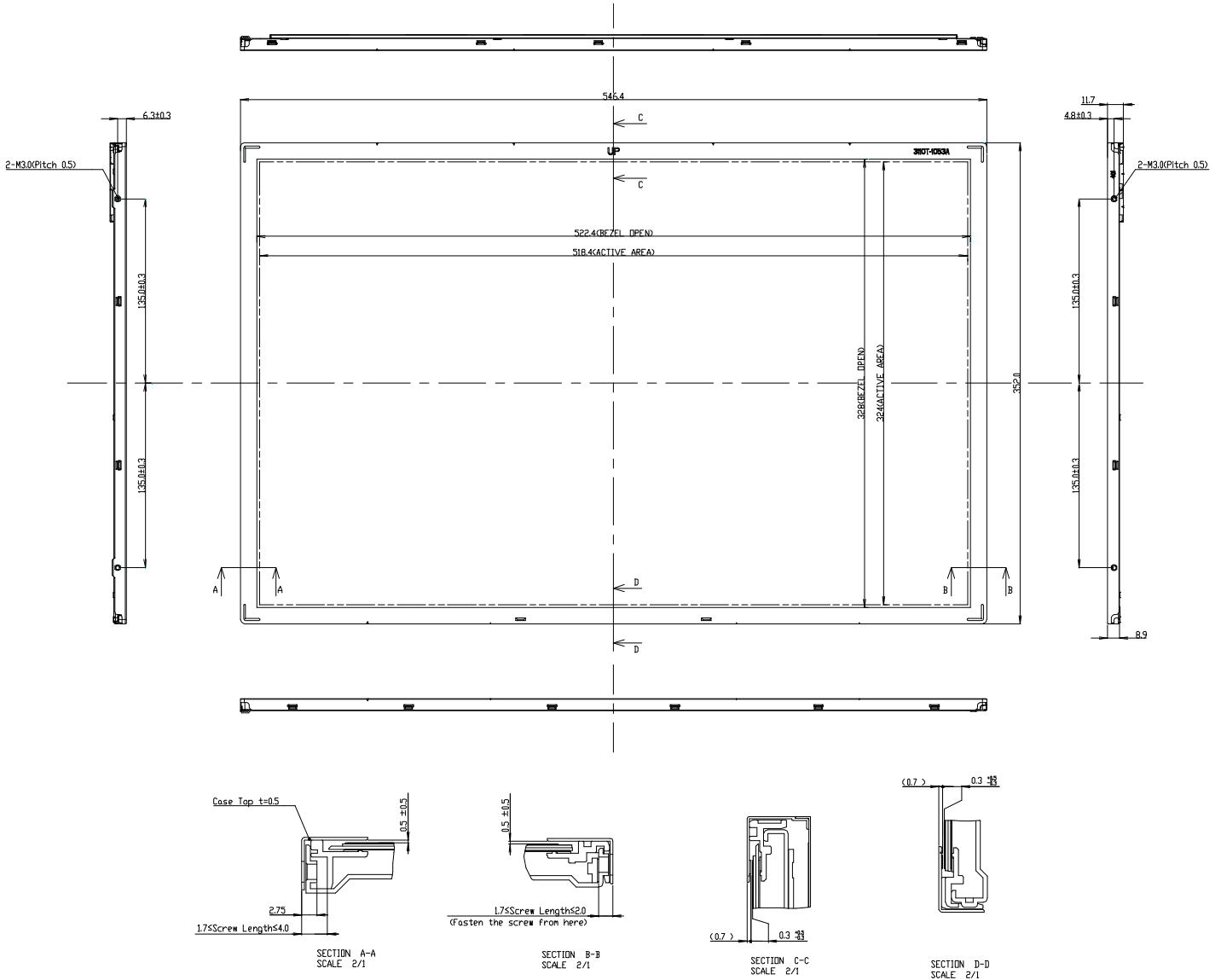

**Product Specification**

**< REAR VIEW >**

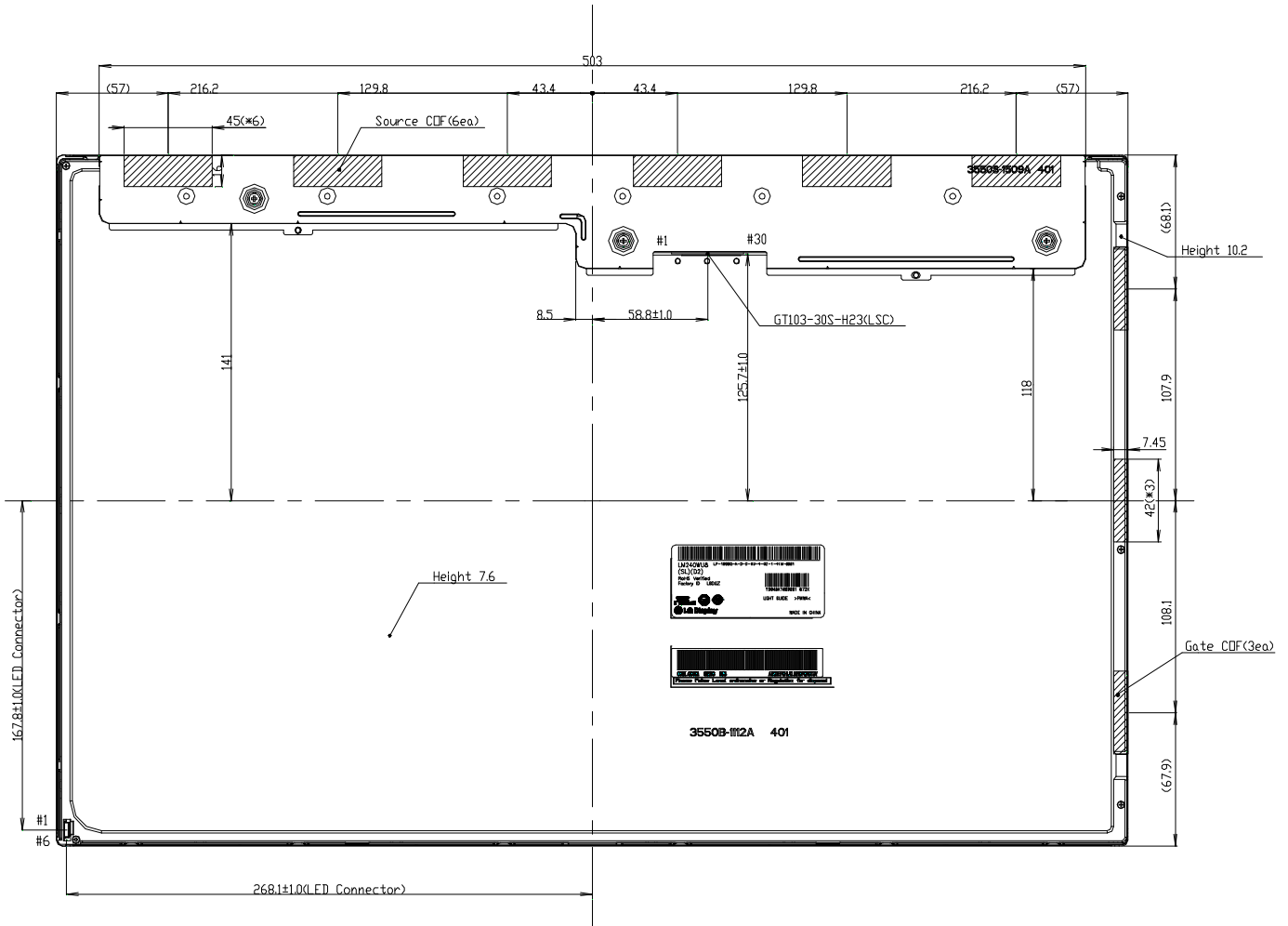

**NOTES**

1. I/F Connector Specification  
- GT103-30S-H23(LSC)
2. LED Connector Specification  
- JST, SM06B-SHJH(HF)
3. Torque of user hole : 3.0~4.0 kgf-cm
4. Tilt and partial disposition tolerance of display area as following  
(1) Y-Direction : |A-B| ≦ 1.4  
(2) X-Direction : |C-D| ≦ 1.4

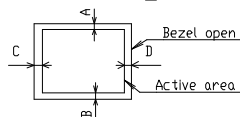

5. Unspecified tolerances to be ±0.5
6. The CDF area is weak & sensitive, so, Please don't press the CDF area

**Product Specification**

## 6. Reliability

**Table 13. Environment test conditions**

No	Test Item	Condition
1	High temperature storage test	Ta= 60°C 240h
2	Low temperature storage test	Ta= -20°C 240h
3	High temperature operation test	Ta= 50°C 50%RH 240h
4	Low temperature operation test	Ta= 0°C 240h
5	Vibration test (non-operating)	Wave form : random Vibration level : 1.0G RMS Bandwidth : 10-300Hz Duration : X,Y,Z, 10 min One time each direction
6	Shock test (non-operating)	Shock level : 100G Waveform : half sine wave, 2ms Direction : ±X, ±Y, ±Z One time each direction
7	Altitude operating storage / shipment	0 – 16,400 feet (5000m) 0 - 40,000 feet (12192m)

{ Result evaluation criteria }

There should be no change which might affect the practical display function when the display quality test is conducted under normal operating condition.

**Product Specification****7. International standards****7-1. Safety**

- a) UL 60950-1, Underwriters Laboratories Inc.  
Information Technology Equipment - Safety - Part 1 : General Requirements.
- b) CAN/CSA C22.2 No.60950-1-07, Canadian Standards Association.  
Information Technology Equipment - Safety - Part 1 : General Requirements.
- c) EN 60950-1, European Committee for Electrotechnical Standardization (CENELEC).  
Information Technology Equipment - Safety - Part 1 : General Requirements.
- d) IEC 60950-1, The International Electrotechnical Commission (IEC).  
Information Technology Equipment - Safety - Part 1 : General Requirements.  
(Including report of IEC60825-1:2001 clause 8 and clause 9)

**Notes**

- 1. Laser (LED Backlight) Information

Class 1M LED Product IEC60825-1 : 2001 Embedded LED Power (Class1M)
---

- 2. Caution
  - : LED inside.
  - Class 1M laser (LEDs) radiation when open.
  - Do not open while operating.

**7-2. EMC**

- a) ANSI C63.4 "American National Standard for Methods of Measurement of Radio-Noise Emissions from Low-Voltage Electrical and Electronic Equipment in the Range of 9 kHz to 40 GHz."  
American National Standards Institute (ANSI), 2003.
- b) CISPR 22 "Information technology equipment – Radio disturbance characteristics – Limit and methods of measurement." International Special Committee on Radio Interference (CISPR), 2005.
- c) CISPR 13 "Sound and television broadcast receivers and associated equipment – Radio disturbance characteristics – Limits and method of measurement." International Special Committee on Radio Interference (CISPR), 2006.

**7-3. Environment**

- a) RoHS, Directive 2002/95/EC of the European Parliament and of the council of 27 January 2003

**Product Specification**

## 8. Packing

### 8-1. Designation of lot mark

a) Lot mark

A	B	C	D	E	F	G	H	I	J	K	L	M
---	---	---	---	---	---	---	---	---	---	---	---	---

A,B,C : Size (Inch)  
E : Month

D : Year  
F ~ M : Serial No.

Note:

1. Year

Year	2011	2012	2013	2014	2015	2016	2017	2018	2019	2020
Mark	A	B	C	D	E	F	G	H	J	K

2. Month

Month	Jan	Feb	Mar	Apr	May	Jun	Jul	Aug	Sep	Oct	Nov	Dec
Mark	1	2	3	4	5	6	7	8	9	A	B	C

b) Location of lot mark

Serial No. is printed on the label. The label is attached to the backside of the LCD module. This is subject to change without prior notice.

### 8-2. Packing form

a) Package quantity in one box : 10 pcs

b) Box size : 408 mm X 355 mm X 600mm

**Product Specification****9. Precautions**

Please pay attention to the followings when you use this TFT LCD module.

**9-1. Mounting Precautions**

- (1) You must mount a module using holes arranged in four corners or four sides.
- (2) You should consider the mounting structure so that uneven force (ex. Twisted stress) is not applied to the Module. And the case on which a module is mounted should have sufficient strength so that external force is not transmitted directly to the module.
- (3) Please attach the surface transparent protective plate to the surface in order to protect the polarizer. Transparent protective plate should have sufficient strength in order to resist external force.
- (4) You should adopt radiation structure to satisfy the temperature specification.
- (5) Acetic acid type and chlorine type materials for the cover case are not desirable because the former generates corrosive gas of attacking the polarizer at high temperature and the latter causes circuit break by electro-chemical reaction.
- (6) Do not touch, push or rub the exposed polarizers with glass, tweezers or anything harder than HB pencil lead. And please do not rub with dust clothes with chemical treatment. Do not touch the surface of polarizer for bare hand or greasy cloth.  
(Some cosmetics are detrimental to the polarizer.)
- (7) When the surface becomes dusty, please wipe gently with absorbent cotton or other soft materials like chamois soaks with petroleum benzene. Normal-hexane is recommended for cleaning the adhesives used to attach front / rear polarizers. Do not use acetone, toluene and alcohol because they cause chemical damage to the polarizer.
- (8) Wipe off saliva or water drops as soon as possible. Their long time contact with polarizer causes deformations and color fading.
- (9) Do not open the case because inside circuits do not have sufficient strength.
- (10) As The IPS panel is sensitive & slim, please recommend the metal frame of the system supports the panel by the double side-mount.

**9-2. Operating precautions**

- (1) The spike noise causes the miss-operation of circuits. It should be lower than following voltage :  $V = \pm 200\text{mV}$  (Over and under shoot voltage)
- (2) Response time depends on the temperature. (In lower temperature, it becomes longer.)
- (3) Brightness depends on the temperature. (In higher temperature, it becomes lower.)  
And in lower temperature, response time (required time that brightness is stable after turned on) becomes longer.
- (4) Be careful for condensation at sudden temperature change. Condensation makes damage to polarizer or electrical contacted parts. And after fading condensation, smear or spot will occur.
- (5) When fixed patterns are displayed for a long time, remnant image is likely to occur.
- (6) Module has high frequency circuits. Sufficient suppression to the electromagnetic interference shall be done by system manufacturers. Grounding and shielding methods may be important to minimized the interference.
- (7) Please do not give any mechanical and/or acoustical impact to LCM. Otherwise, LCM can not be operated its full characteristics perfectly.
- (8) A screw which is fastened up the steels should be a machine screw (if not, it causes metal foreign material and deal LCM a fatal blow)
- (9) Please do not set LCD on its edge.
- (10) When LCMs are used for public display defects such as Yogure, image sticking can not be guarantee.
- (11) LCMs cannot support "Interlaced Scan Method"

**Product Specification****9-3. Electrostatic discharge control**

Since a module is composed of electronic circuits, it is not strong to electrostatic discharge. Make certain that treatment persons are connected to ground through wrist band etc. And don't touch interface pin directly.

**9-4. Precautions for strong light exposure**

Strong light exposure causes degradation of polarizer and color filter.

**9-5. Storage**

When storing modules as spares for a long time, the following precautions are necessary.

- (1) Store them in a dark place. Do not expose the module to sunlight or fluorescent light. Keep the temperature between 5°C and 35°C at normal humidity.
- (2) The polarizer surface should not come in contact with any other object.  
It is recommended that they be stored in the container in which they were shipped.

**9-6. Handling precautions for protection film**

- (1) The protection film is attached to the bezel with a small masking tape.  
When the protection film is peeled off, static electricity is generated between the film and polarizer. This should be peeled off slowly and carefully by people who are electrically grounded and with well ion-blown equipment or in such a condition, etc.
- (2) When the module with protection film attached is stored for a long time, sometimes there remains a very small amount of glue still on the bezel after the protection film is peeled off.
- (3) You can remove the glue easily. When the glue remains on the bezel surface or its vestige is recognized, please wipe them off with absorbent cotton waste or other soft material like chamois soaked with normal-hexane.