

LM2429

Monolithic Triple Channel 15 MHz DTV Driver

General Description

The LM2429 is an integrated high voltage CRT driver circuit designed for use in DTV applications. The IC contains three high input impedance, wide band amplifiers which directly drive the RGB cathodes of a CRT. Each channel has its gain internally set to -51 and can drive CRT capacitive loads as well as resistive loads present in other applications, limited only by the package's power dissipation.

The IC is packaged in an industry standard 11-lead TO-220 molded plastic power package designed specifically to meet high voltage spacing requirements. See Thermal Considerations section.

Features

- 0V to 5V input range
- Greater than $130V_{PP}$ output swing capability
- Stable with 0–20 pF capacitive loads and inductive peaking networks
- Convenient TO-220 staggered thin lead package style

Applications

- AC coupled DTV applications using the 480p format as well as standard NTSC and PAL formats.

Connection Diagram

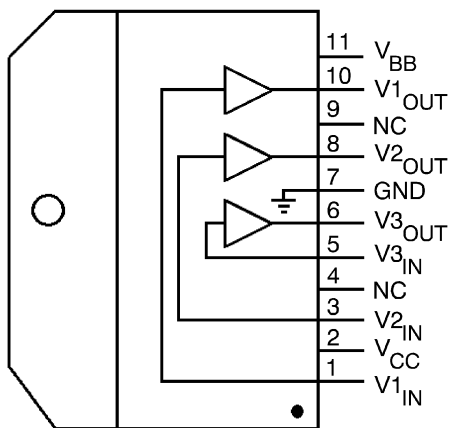

Note: Tab is at GND

Top View
Order Number LM2429

20073102

FIGURE 1. Simplified Connection and Pinout Diagram

Schematic Diagram

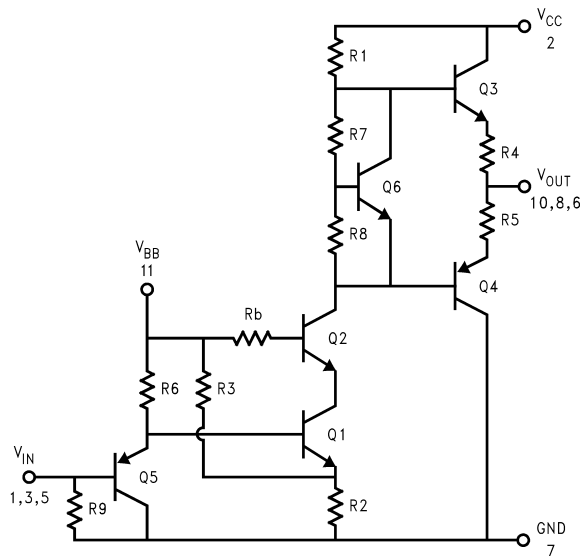

20073101

FIGURE 2. Simplified Schematic Diagram
(One Channel)

Absolute Maximum Ratings (Notes 1,

3)

If Military/Aerospace specified devices are required, please contact the National Semiconductor Sales Office/Distributors for availability and specifications.

Supply Voltage (V_{CC})	+200V
Bias Voltage (V_{BB})	+15V
Input Voltage (V_{IN})	-0.5V to V_{BB} +0.5V
Storage Temperature Range (T_{STG})	-65°C to +150°C
Lead Temperature (Soldering, <10 sec.)	300°C
ESD Tolerance, Human Body Model	2kV
Machine Model	200V
Junction Temperature	150°C
θ_{JC} (typ)	2.9°C/W

Operating Ranges (Note 2)

V_{CC}	+130V to +180V
V_{BB}	+7V to +13V
V_{IN}	+0V to +4V
V_{OUT}	+15V to +175V
Case Temperature	Refer to Figure 11
Do not operate the part without a heat sink.	

Electrical Characteristics

(See Figure 3 for Test Circuit) Unless otherwise noted: $V_{CC} = +180V$, $V_{BB} = +8V$, $C_L = 8pF$, $T_C = 50^\circ C$. DC Tests: $V_{IN} = 2.5V_{DC}$. AC Tests: Output = 130V_{PP} (35V - 165V) at 1MHz.

Symbol	Parameter	Conditions	LM2429			Units
			Min	Typical	Max	
I_{CC}	Supply Current	All Three Channels, No Input Signal, No Output Load		16	30	mA
I_{BB}	Bias Current	All Three Channels		12	17	mA
$V_{OUT, 1}$	DC Output Voltage	No AC Input Signal, $V_{IN} = 2.5V_{DC}$	100	105	110	V_{DC}
$V_{OUT, 2}$	DC Output Voltage	No AC Input Signal, $V_{IN} = 1.2V_{DC}$	163	168	173	V_{DC}
A_V	DC Voltage Gain	No AC Input Signal	-48	-51	-54	
ΔA_V	Gain Matching	(Note 4), No AC Input Signal		1.0		dB
LE	Linearity Error	(Notes 4, 5), No AC Input Signal		8		%
t_R	Rise Time	(Note 6), 10% to 90%		26		ns
t_F	Fall Time	(Note 6), 90% to 10%		30		ns
OS	Overshoot	(Note 6)		5		%

Note 1: Absolute Maximum Ratings indicate limits beyond which damage to the device may occur.

Note 2: Operating ratings indicate conditions for which the device is functional, but do not guarantee specific performance limits. For guaranteed specifications and test conditions, see the Electrical Characteristics. Datasheet min/max specification limits are guaranteed by design, test, or statistical analysis. The guaranteed specifications apply only for the test conditions listed. Some performance characteristics may change when the device is not operated under the listed test conditions.

Note 3: All voltages are measured with respect to GND, unless otherwise specified.

Note 4: Calculated value from Voltage Gain test on each channel.

Note 5: Linearity Error is the variation in DC gain from $V_{IN} = 1.1V$ to $V_{IN} = 3.8V$.

Note 6: Input from signal generator: $t_r, t_f < 1$ ns.

AC Test Circuit

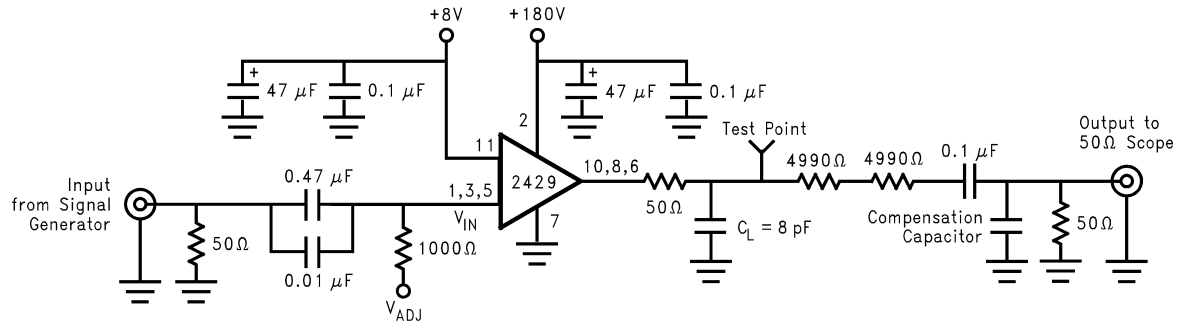

20073103

Note: 8pF load includes parasitic capacitance.

FIGURE 3. Test Circuit (One Channel)

Figure 3 shows a typical test circuit for evaluation of the LM2429. This circuit is designed to allow testing of the LM2429 in a 50Ω environment without the use of an expensive FET probe. The two 4990Ω resistors form a 400:1 divider with the 50Ω resistor and the oscilloscope. A test point is included for easy use of an oscilloscope probe. The compensation capacitor is used to compensate the network to achieve flat frequency response.

Typical Performance Characteristics ($V_{CC} = +180V_{DC}$, $V_{BB} = +8V_{DC}$, $C_L = 8pF$, $V_{OUT} = 130V_{PP}$ (35V – 165V), Test Circuit - Figure 3 unless otherwise specified)

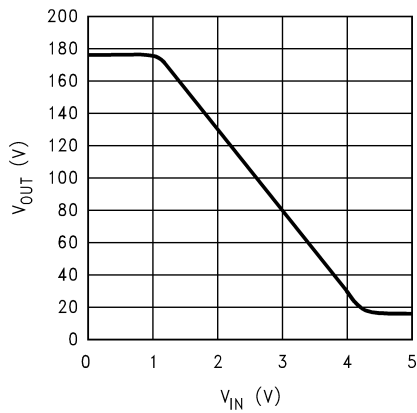

20073104

FIGURE 4. V_{OUT} vs V_{IN}

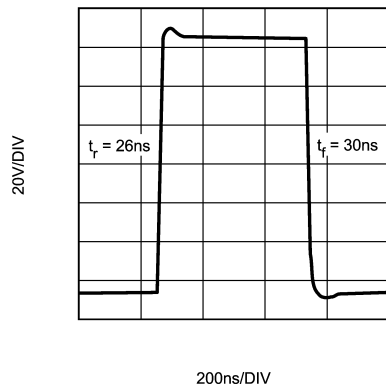

20073106

FIGURE 5. LM2429 Pulse Response

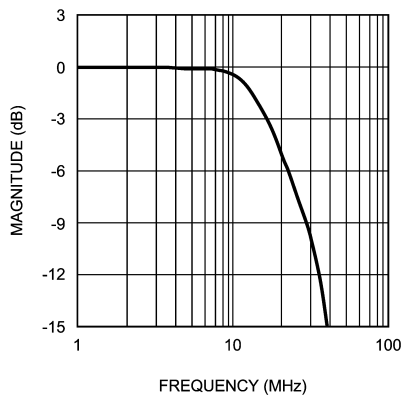

20073118

FIGURE 6. Bandwidth

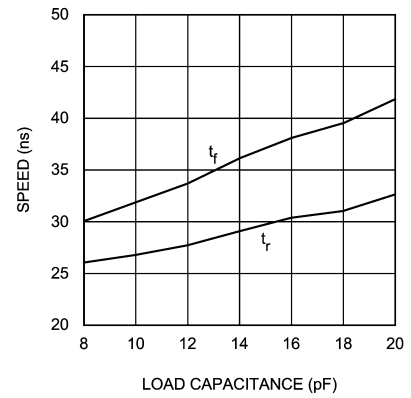

20073105

FIGURE 7. Speed vs Load Capacitance

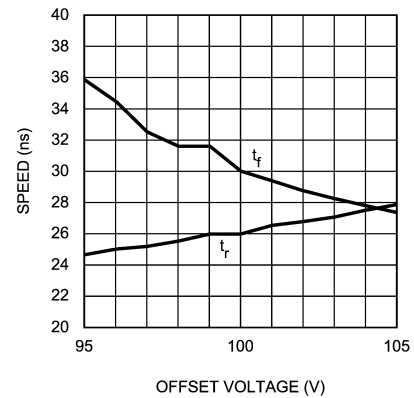

20073108

FIGURE 8. Speed vs Offset

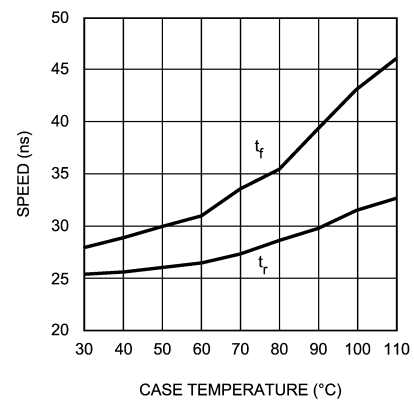

20073109

FIGURE 9. Speed vs Case Temperature

Typical Performance Characteristics ($V_{CC} = +180V_{DC}$, $V_{BB} = +8V_{DC}$, $C_L = 8pF$, $V_{OUT} = 130V_{PP}$ (35V – 165V), Test Circuit - Figure 3 unless otherwise specified) (Continued)

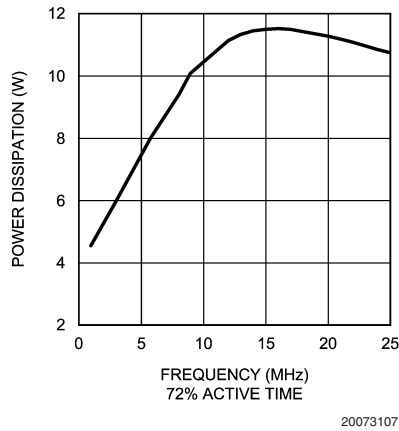

FIGURE 10. Power Dissipation vs Frequency

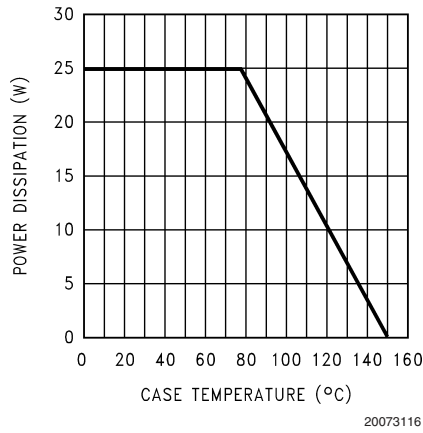

FIGURE 11. Power Derating Curve

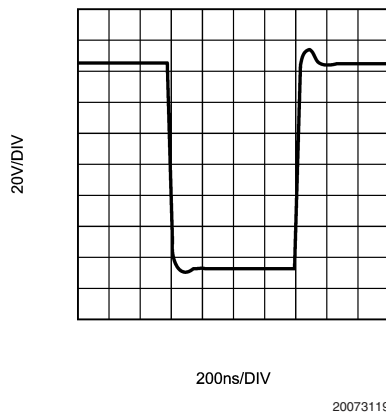

FIGURE 12. Cathode Pulse Response

Typical Performance Characteristics

($V_{CC} = +180V_{DC}$, $V_{BB} = +8V_{DC}$, $C_L = 8pF$, $V_{OUT} = 130V_{PP}$ (35V – 165V), Test Circuit - Figure 3 unless otherwise specified) (Continued)

TABLE 1. Power Dissipation for Various Video Patterns

Power Dissipation (W)		
Pattern	Format	
	480i	480p
Raster	1.8	1.8
Full White Field	4.0	4.0
White Box, 75% Screen Size	3.1	3.1
Gray Bars	3.2	3.3
Color Bars 75% Amplitude	2.7	2.8
Color Bars 100% Amplitude	3.0	3.0
SMPTE Color Bars	2.7	2.7
SMPTE 133	3.6	3.9
Cross Hatch 16x12	2.3	2.6
Resolution Chart	3.8	4.1
Multiburst	5.2	7.3
White Text on Black Background	6.1	8.9
Windows Pattern	3.4	4.3
Windows Pattern	3.7	4.4
Windows Pattern	5.0	6.2
Vertical Lines 5 On 5 Off	4.6	6.3
Vertical Lines 4 On 4 Off	5.0	7.1
Vertical Lines 3 On 3 Off	5.6	8.7
Vertical Lines 2 On 2 Off	7.2	11.4
Vertical Lines 1 On 1 Off	11.5	15.4

Note: Input from signal generator: t_r , $t_f < 2$ ns.

Theory of Operation

The LM2429 is a high voltage monolithic three channel CRT driver suitable for HDTV applications. The LM2429 operates with 180V and 8V power supplies. The part is housed in the industry standard 11-lead TO-220 molded plastic power package with thin leads for improved metal-to-metal spacing.

The circuit diagram of the LM2429 is shown in Figure 2. The PNP emitter follower, Q5, provides input buffering. Q1 and Q2 form a fixed gain cascode amplifier with resistors R1 and R2 setting the gain at -51 . Emitter followers Q3 and Q4 isolate the high output impedance of the cascode stage from the capacitance of the CRT cathode which decreases the sensitivity of the device to load capacitance. Q6 provides biasing to the output emitter follower stage to reduce cross-over distortion at low signal levels.

Figure 3 shows a typical test circuit for evaluation of the LM2429. This circuit is designed to allow testing of the LM2429 in a 50Ω environment without the use of an expensive FET probe. In this test circuit, the two $4.99k\Omega$ resistors form a 400:1 wideband, low capacitance probe when connected to a 50Ω coaxial cable and a 50Ω load (such as a 50Ω oscilloscope input). The input signal from the generator is ac coupled to the base of Q5.

Application Hints

INTRODUCTION

National Semiconductor (NSC) is committed to provide application information that assists our customers in obtaining the best performance possible from our products. The following information is provided in order to support this commitment. The reader should be aware that the optimization of performance was done using a specific printed circuit board designed at NSC. Variations in performance can be realized due to physical changes in the printed circuit board and the application. Therefore, the designer should know that component value changes may be required in order to optimize performance in a given application. The values shown in this document can be used as a starting point for evaluation purposes. When working with high bandwidth circuits, good layout practices are also critical to achieving maximum performance.

IMPORTANT INFORMATION

The LM2429 performance is targeted for the HDTV market. The application circuits shown in this document to optimize performance and to protect against damage from CRT arcover are designed specifically for the LM2429. If another member of the LM242X family is used, please refer to its datasheet.

Application Hints (Continued)

POWER SUPPLY BYPASS

Since the LM2429 is a wide bandwidth amplifier, proper power supply bypassing is critical for optimum performance. Improper power supply bypassing can result in large overshoot, ringing or oscillation. 0.1µF capacitors should be connected from the supply pins, V_{CC} and V_{BB} , to ground, as close to the LM2429 as is practical. Additionally, a 22µF or larger electrolytic capacitor should be connected from both supply pins to ground reasonably close to the LM2429.

ARC PROTECTION

During normal CRT operation, internal arcing may occasionally occur. Spark gaps, in the range of 300V, connected from the CRT cathodes to CRT ground will limit the maximum voltage, but to a value that is much higher than allowable on the LM2429. This fast, high voltage, high energy pulse can damage the LM2429 output stage. The application circuit shown in *Figure 13* is designed to help clamp the voltage at the output of the LM2429 to a safe level. The clamp diodes, D1 and D2, should have a fast transient response, high peak current rating, low series impedance and low shunt capacitance. 1SS83 or equivalent diodes are recommended. D1 and D2 should have short, low impedance connections to V_{CC} and ground respectively. The cathode of D1 should be located very close to a separately decoupled bypass capacitor (C3 in *Figure 13*). The ground connection of D2 and the decoupling capacitor should be very close to the LM2429 ground. This will significantly reduce the high frequency voltage transients that the LM2429 would be subjected to during an arcover condition. Resistor R2 limits the arcover current that is seen by the diodes while R1 limits the current into the LM2429 as well as the voltage stress at the outputs of the device. R2 should be a 1/2W solid carbon type resistor. R1 can be a 1/4W metal or carbon film type resistor. Having large value resistors for R1 and R2 would be desirable, but this has the effect of increasing rise and fall times. Inductor L1 is critical to reduce the initial high frequency voltage levels that the LM2429 would be subjected to. The inductor will not only help protect the device but it will also help minimize rise and fall times as well as minimize EMI. For proper arc protection, it is important to not omit any of the arc protection components shown in *Figure 13*.

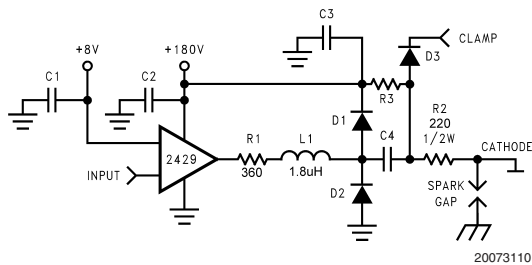

FIGURE 13. One Channel of the LM2429 with the Recommended Application Circuit

EFFECT OF LOAD CAPACITANCE

Figure 7 shows the effect of increased load capacitance on the speed of the device. This demonstrates the importance of knowing the load capacitance in the application.

EFFECT OF OFFSET

Figure 8 shows the variation in rise and fall times when the output offset of the device is varied from 95V to 105V_{DC}. The rise time shows a variation of less than 8% relative to the center data point (100V_{DC}). The fall time shows a variation of less than 9% relative to the center data point.

THERMAL CONSIDERATIONS

Figure 9 shows the performance of the LM2429 in the test circuit shown in *Figure 3* as a function of case temperature. The figure shows that the rise and fall times of the LM2429 increase by approximately 15% and 30%, respectively, as the case temperature increases from 50°C to 90°C. This corresponds to a speed degradation of 3.75% and 7.5% for every 10°C rise in case temperature.

Figure 10 shows the power dissipation of the LM2429 vs. Frequency when all three channels of the device are driving an 8pF load with a 130V_{PP} alternating one pixel on, one pixel off signal. The graph assumes a 72% active time (device operating at the specified frequency) which is typical in a TV application. The other 28% of the time the device is assumed to be sitting at the black level (165V in this case). *Table 1* also shows the typical power dissipation of the LM2429 for various video patterns in the 480i and 480p video formats.

Figure 10, *Figure 11*, and *Table 1* give the designer the information needed to determine the heatsink requirement for the LM2429. For example, if an HDTV application uses the 480p format and "Vertical Lines 2 On 2 Off" is assumed to be the worst-case pattern to be displayed, then the power dissipated will be 11.4W (from *Table 1*). *Figure 11* shows that the maximum allowed case temperature is 117°C when 11.4W is dissipated. If the maximum expected ambient temperature is 70°C, then a maximum heatsink thermal resistance can be calculated:

$$R_{TH} = \frac{117^{\circ}\text{C} - 70^{\circ}\text{C}}{11.4\text{W}} = 4.1^{\circ}\text{C}$$

This example assumes a capacitive load of 8pF and no resistive load. The designer should note that if the load capacitance is increased the AC component of the total power dissipation will also increase.

Note: A LM126X preamplifier, with rise and fall times of about 2 ns, was used to drive the LM2429 for these power measurements. Using a preamplifier with rise and fall times slower than the LM126X will cause the LM2429 to dissipate less power than shown in *Table 1*.

OPTIMIZING TRANSIENT RESPONSE

In *Figure 13*, there are three components (R1, R2 and L1) that can be adjusted to optimize the transient response of the application circuit. Increasing the values of R1 and R2 will slow the circuit down while decreasing overshoot. Increasing the value of L1 will speed up the circuit as well as increase overshoot. It is very important to use inductors with very high self-resonant frequencies, preferably above 300 MHz. Ferrite core inductors from J.W. Miller Magnetics (part # 78FR__k) were used for optimizing the performance of the device in the NSC application board. The values shown in *Figure 14* and *Figure 15* can be used as a good starting point for the evaluation of the LM2429. Using a variable resistor for R1 will simplify finding the value needed for optimum performance in a given application. Once the optimum value is determined, the variable resistor can be replaced with a fixed value.

Application Hints (Continued)

Figure 12 shows the typical cathode pulse response with an output swing of $130V_{PP}$ using a LM1269 preamplifier.

PC BOARD LAYOUT CONSIDERATIONS

For optimum performance, an adequate ground plane, isolation between channels, good supply bypassing and minimizing unwanted feedback are necessary. Also, the length of the signal traces from the preamplifier to the LM2429 and from the LM2429 to the CRT cathode should be as short as possible. The following references are recommended:

Ott, Henry W., "Noise Reduction Techniques in Electronic Systems", John Wiley & Sons, New York, 1976.

"Video Amplifier Design for Computer Monitors", National Semiconductor Application Note 1013.

Pease, Robert A., "Troubleshooting Analog Circuits", Butterworth-Heinemann, 1991.

Because of its high small signal bandwidth, the part may oscillate in a TV if feedback occurs around the video channel through the chassis wiring. To prevent this, leads to the video amplifier input circuit should be shielded, and input circuit wiring should be spaced as far as possible from output circuit wiring.

TYPICAL APPLICATION

A typical application of the LM2429 is shown in the schematic for the NSC demonstration board in *Figure 14* and *Figure 15*. Used in conjunction with an LM126X preamplifier, a complete video channel from input to CRT cathode can be achieved. Performance is ideal for DTV applications. The NSC demonstration board can be used to evaluate the LM126X/LM2429 combination in a TV.

NSC DEMONSTRATION BOARD

Figure 16 shows the routing and component placement on the NSC LM126X/LM2429 demonstration board. This board provides a good example of a layout that can be used as a guide for future layouts. Note the location of the following components:

- C19— V_{CC} bypass capacitor, located very close to pin 2 and ground pins
- C20— V_{BB} bypass capacitor, located close to pin 11 and ground
- C46, C48— V_{CC} bypass capacitors, near LM2429 and V_{CC} clamp diodes. Very important for arc protection.

The routing of the LM2429 outputs to the CRT is very critical to achieving optimum performance. *Figure 17* shows the routing and component placement from pin 10 ($V1_{OUT}$) of the LM2429 to the blue cathode. Note that the components are placed so that they almost line up from the output pin of the LM2429 to the blue cathode pin of the CRT connector. This is done to minimize the length of the video path between these two components. Note also that D8, D9, R24 and D6 are placed to minimize the size of the video nodes that they are attached to. This minimizes parasitic capacitance in the video path and also enhances the effectiveness of the protection diodes. The anode of protection diode D8 is connected directly to a section of the the ground plane that has a short and direct path to the LM2429 ground pins. The cathode of D9 is connected to V_{CC} very close to decoupling capacitor C48 which is connected to the same section of the ground plane as D8. The diode placement and routing is very important for minimizing the voltage stress on the LM2429 during an arcover event. Lastly, notice that S3 is placed very close to the blue cathode and is tied directly to CRT ground.

This demonstration board uses large PCB holes to accommodate socket pins, which function to allow for multiple insertions of the LM2429 in a convenient manner. To benefit from the enhanced LM2429 package with thin leads, the device should be secured in small PCB holes to optimize the metal-to-metal spacing between the leads.

Application Hints (Continued)

LM2429

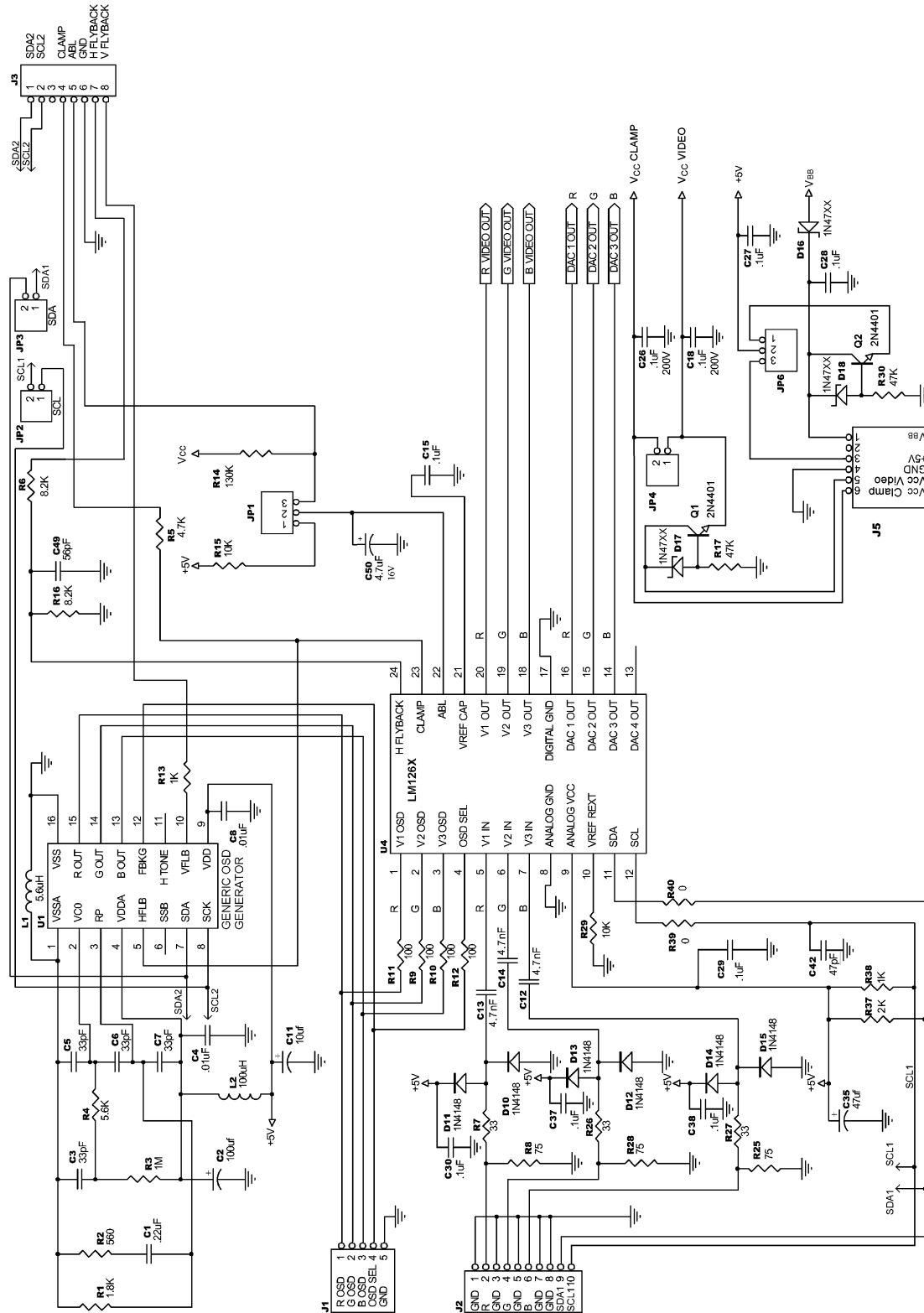

20073111

FIGURE 14. LM126X/LM242X/LM248X Demonstration Board Schematic

Application Hints (Continued)

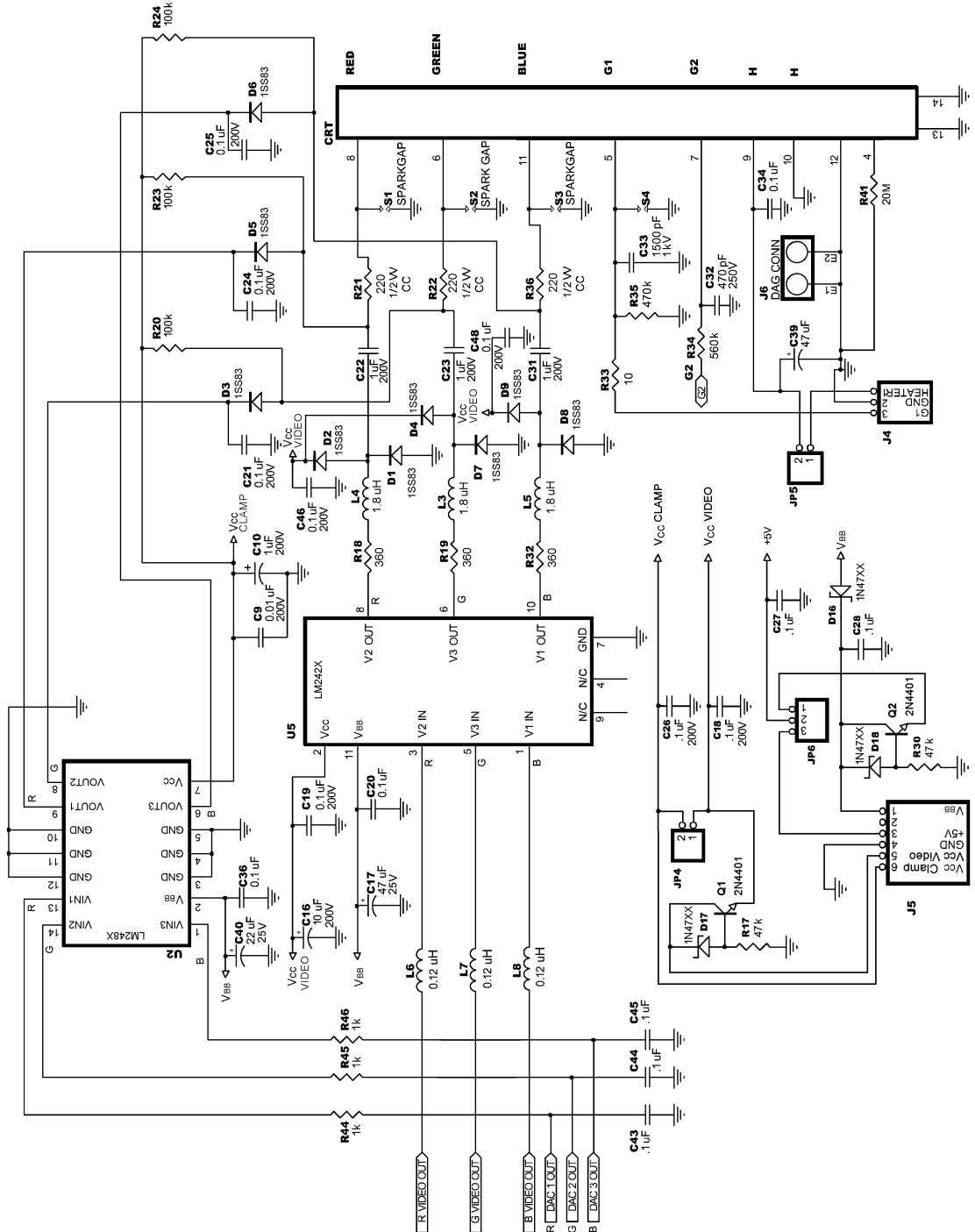
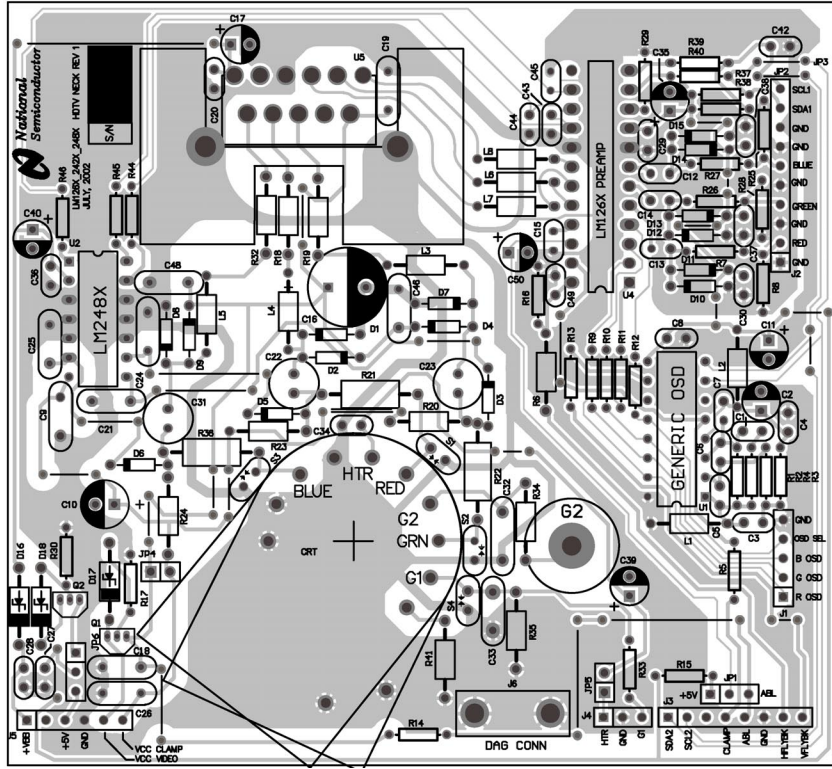

FIGURE 15. LM262X/LM242X/LM248X Demonstration Board Schematic (continued)

20073112

Application Hints (Continued)



20073113

FIGURE 16. LM126X/LM242X/LM248X Demonstration Board Layout

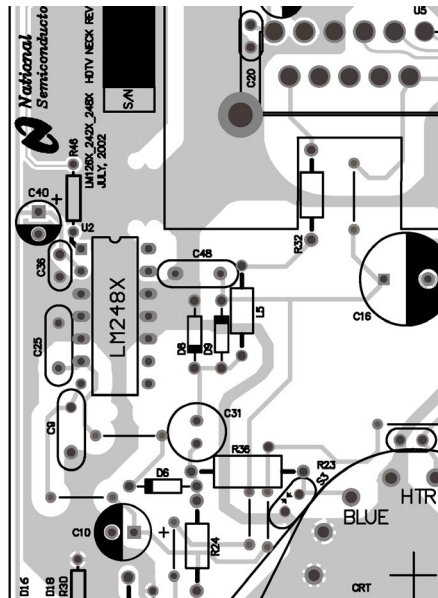

20073114

FIGURE 17. Trace Routing and Component Placement for Blue Channel Output

Physical Dimensions inches (millimeters) unless otherwise noted

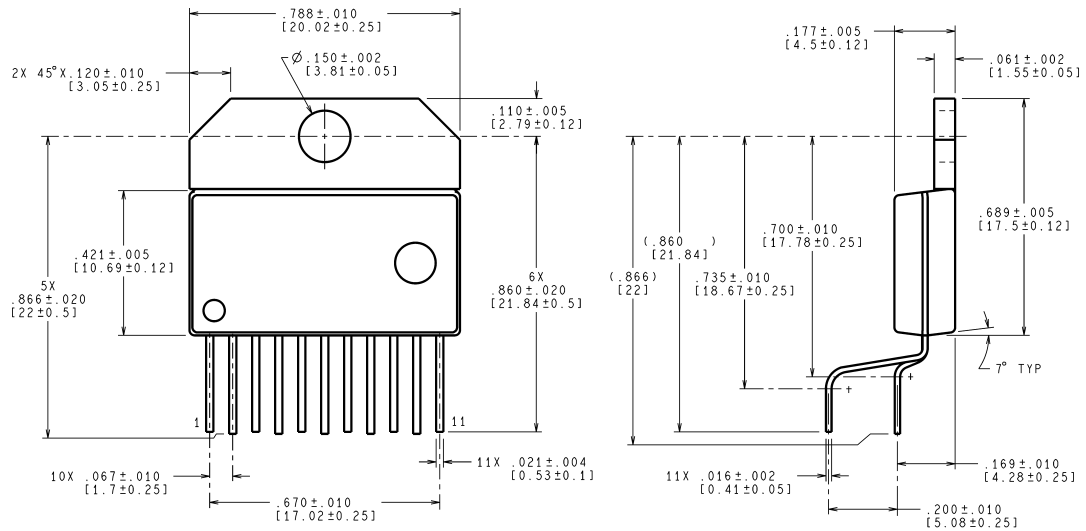

CONTROLLING DIMENSION IS INCH
VALUES IN [] ARE MILLIMETERS

TE11B (Rev A)

CONTROLLING DIMENSION IS INCH
VALUES IN [] ARE MILLIMETERS

NS Package Number TE11B
Order Number LM2429

National does not assume any responsibility for use of any circuitry described, no circuit patent licenses are implied and National reserves the right at any time without notice to change said circuitry and specifications.

For the most current product information visit us at www.national.com.

LIFE SUPPORT POLICY

NATIONAL'S PRODUCTS ARE NOT AUTHORIZED FOR USE AS CRITICAL COMPONENTS IN LIFE SUPPORT DEVICES OR SYSTEMS WITHOUT THE EXPRESS WRITTEN APPROVAL OF THE PRESIDENT AND GENERAL COUNSEL OF NATIONAL SEMICONDUCTOR CORPORATION. As used herein:

1. Life support devices or systems are devices or systems which, (a) are intended for surgical implant into the body, or (b) support or sustain life, and whose failure to perform when properly used in accordance with instructions for use provided in the labeling, can be reasonably expected to result in a significant injury to the user.
2. A critical component is any component of a life support device or system whose failure to perform can be reasonably expected to cause the failure of the life support device or system, or to affect its safety or effectiveness.

BANNED SUBSTANCE COMPLIANCE

National Semiconductor certifies that the products and packing materials meet the provisions of the Customer Products Stewardship Specification (CSP-9-111C2) and the Banned Substances and Materials of Interest Specification (CSP-9-111S2) and contain no "Banned Substances" as defined in CSP-9-111S2.



National Semiconductor
Americas Customer Support Center
Email: new.feedback@nsc.com
Tel: 1-800-272-9959

National Semiconductor
Europe Customer Support Center
Fax: +49 (0) 180-530 85 86
Email: europe.support@nsc.com
Deutsch Tel: +49 (0) 69 9508 6208
English Tel: +44 (0) 870 24 0 2171
Français Tel: +33 (0) 1 41 91 8790

National Semiconductor
Asia Pacific Customer Support Center
Email: ap.support@nsc.com

National Semiconductor
Japan Customer Support Center
Fax: 81-3-5639-7507
Email: jpn.feedback@nsc.com
Tel: 81-3-5639-7560